



1 2 3 4 5 6 7 8 9 10

11 12 13 14 15 16 17 18 19 20

21 22 23 24 25 26 27 28 29 30

31 32 33 34 35 36 37 38 39 40



41 42 43 44 45 46 47 48 49 50

# Ma boîte à outils en mathématiques

Des outils qui appuient le raisonnement et l'apprentissage en mathématiques de la maternelle à la 4<sup>e</sup> année.

71 72 73 74 75 76 77 78 79 80

81 82 83 84 85 86 87 88 89 90

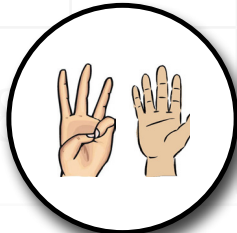
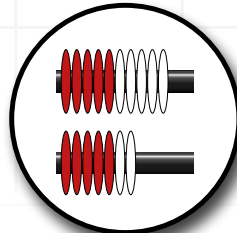
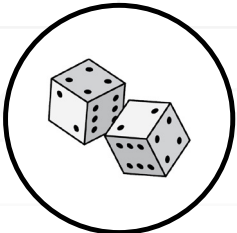
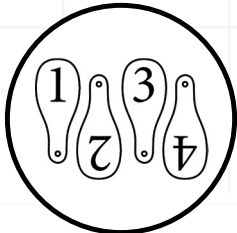
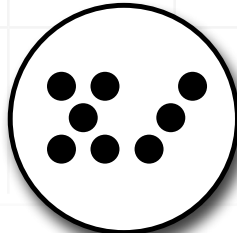

91 92 93 94 95 96 97 98 99 100



Données de catalogage avant publication – Éducation et Formation Manitoba

Ma boîte à outils en mathématiques : des outils qui appuient le raisonnement et l'apprentissage en mathématiques de la maternelle à la 4<sup>e</sup> année.

Comprend des références bibliographiques.  
ISBN : 978-0-7711-7160-4 (PDF)

1. Mathématiques - Étude et enseignement (Primaire)
  2. Mathématiques - Étude et enseignement (Élémentaire)
  3. Mathématiques - Problèmes et exercices (Primaire)
  4. Mathématiques - Problèmes et exercices (Élémentaire)
  5. Jeux mathématiques
- I. Manitoba. Éducation Manitoba  
510.76

Tous droits réservés © 2021, le gouvernement du Manitoba représenté par le ministre de l'Éducation.

Éducation Manitoba  
Bureau de l'éducation française  
Winnipeg (Manitoba) Canada

Les illustrations ou photographies dans ce document sont protégées par la *Loi sur le droit d'auteur* et ne doivent pas être extraites ou reproduites pour aucune raison autre que pour les intentions pédagogiques explicitées dans ce document.

La version électronique de ce document est affichée sur le site Web du ministère de l'Éducation du Manitoba au [https://www.edu.gov.mb.ca/m12/frpub/ped/ma/boite\\_outils/index.html](https://www.edu.gov.mb.ca/m12/frpub/ped/ma/boite_outils/index.html). Veuillez noter que le Ministère pourrait apporter des changements à la version en ligne.

Les sites Web pourraient faire l'objet de changement sans préavis.

Le Ministère s'est engagé à rendre ses publications aussi accessibles que possible. Toutefois, certaines parties du présent document ne sont pas accessibles pour le moment.

Disponible en médias substitués sur demande.

*This document is available in English.*

**Dans le présent document, le genre masculin appliqué aux personnes est employé sans aucune discrimination et uniquement dans le but d'alléger le texte.**

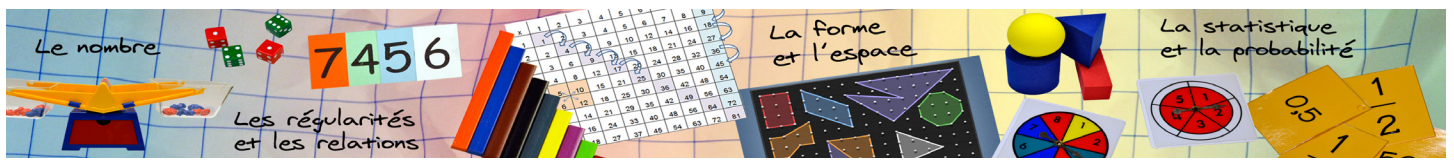

# Tables des matières

<b>Pourquoi une boîte à outils en mathématiques? .....</b>	<b>1</b>
<b>Astuces suggérées .....</b>	<b>3</b>
<b>Étiquettes pour les boîtes à outils en mathématiques .....</b>	<b>4</b>
<b>Feuilles reproductibles (FR) .....</b>	<b>5</b>
Arrangement rectangulaire de points.....	5
Balance.....	6
Bande numérique de 1 à 20.....	7
Blocs de base dix – représentation imagée .....	7
Cartes à 5 points.....	8
. Petit format	
. Grand format	
Cartes à 10 points – représentation imagée .....	8
. Simple (Petit format et Grand format)	
. Double (Petit format et Grand format)	
. Vide (Horizontale et Verticale)	
Cartes de la partie manquante .....	9
Cartes de nombres (0 à 100) et de symboles d'opération .....	9
. Cartes de nombres (0 à 100)	
. Cartes de symboles d'opération	
Cartes de reconnaissance globale.....	10
. Doigts de la main (1 à 10)	
. Constellations de points familiers et non familiers (1 à 10) (Format rectangulaire et Format circulaire)	
. Constellations de points familiers (1 à 6)	
Carte de représentations concrète et symbolique des nombres de 1 à 10 .....	11
. Coccinelle	
. Arbre	
Cartes de représentations imagée et symbolique des nombres.....	11
. Appariements (1 à 10)	
. Chiffres et lettres (1 à 20)	
Cartes de représentations imagée et symbolique des nombres jusqu'à 20 .....	12
. Trains ou tours de cubes (Petit format et Grand format)	
. Arrangements de points (Petit format et Grand format)	
. Nombres (Petit format et Grand format)	
. Boulier 2 x 10 (Petit format et Grand format)	
. 10 points (Petit format et Grand format)	
. Doigts de deux paires de mains (1 à 20)	
. Doigts (0 à 20) avec nombres	
. Doigts (1 à 20)	
. Doigts de deux paires de mains avec ou sans nombres de 0 à 20	



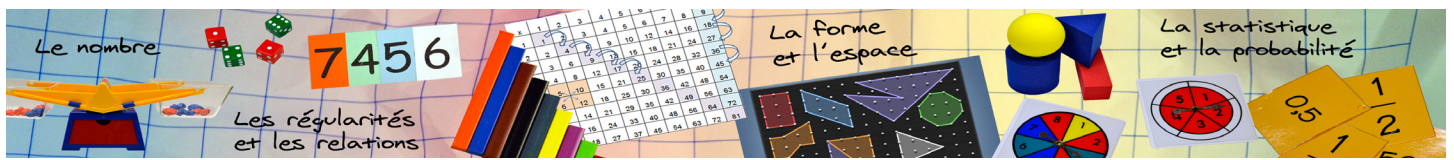

Dé.....	13
Développements d'objets à trois dimensions.....	13
. Cube	
. Prisme à base rectangulaire	
. Prisme à base triangulaire	
Droites numériques.....	14
. Horizontale de 0 à 100 avec graduations accentuées et chacun des nombres de 0 à 100	
. Horizontale de 0 à 100 avec graduations accentuées et nombres montrant les multiples de 10	
. Horizontale vide avec graduations accentuées	
. Horizontale vide avec nombre réduit de graduations accentuées	
. Horizontale ouverte	
. Horizontales avec points de repère variés	
. Verticale de 0 à 100 avec graduations accentuées et chacun des nombres de 0 à 100	
. Verticale de 0 à 100 avec graduations accentuées et nombres montrant les multiples de 10	
. Verticale vide avec graduations accentuées	
. Verticale vide avec nombre réduit de graduations accentuées	
. Verticale ouverte	
Ensemble de dominos.....	15
Ensemble de polygones.....	15
. réguliers	
. irréguliers	
Éventails de nombres.....	16
. Éventail (0 à 9) avec décimales	
. Palette (0 à 9) avec décimales	
. Palette (0 à 10) de cartes à 10 points	
Fiches de référence.....	16
. Bande numérique de 1 à 10 représentation imagée et symbolique	
. Nombres en chiffres et en lettres	
Fiches fractionnaires.....	17
. Bandes fractionnaires	
. Cercles fractionnaires	
Les Roulettes.....	17
. Chiffres	
. Cartes à points	
. Symboles d'opérations	
. Relations (+1, +2, -1, - 2)	
. Vides	
Nombre du jour.....	18
. Maternelle	
. 1 <sup>re</sup> année	
. 2 <sup>e</sup> année	
. 3 <sup>e</sup> année	
. 4 <sup>e</sup> année	



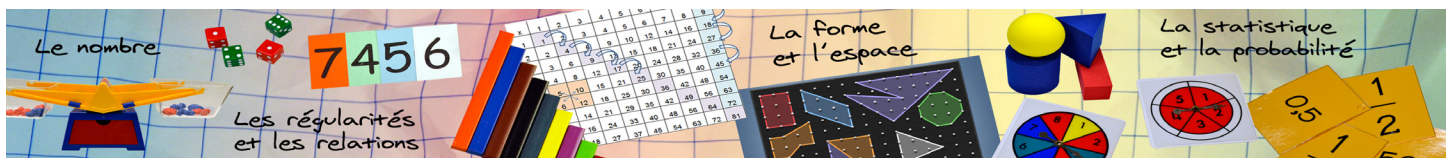

Tableaux de nombres .....	19
. 1 à 20	
. 1 à 30	
. 0 à 100	
. 0 à 99	
. 100 vide	
. Quatre petits tableaux de 1 à 100	
. 1 à 120	
. 1 à 200	
. 1 à 100 - du bas vers le haut	
. 1 à 200 - du bas vers le haut	
. Générateur de tableaux de 100 <a href="https://www.edu.gov.mb.ca/m12/progetu/ma/ressources.html">https://www.edu.gov.mb.ca/m12/progetu/ma/ressources.html</a>	
Valeur de position - Pochettes des valeurs de position (représentation symbolique) .....	20
. Centaine	
. Millier	
. Dixième	
. Centième	
. Cartes de chiffres de 0 à 9	
Valeur de position - Tapis des valeurs de position (représentations concrète, imagée et symbolique) .....	21
. Vides	
. Imagés	
. Exemples	
Valeur de position - Tentés de nombres jusqu'à 9999 (représentation symbolique) .....	21
<b>Matériel de manipulation pour la boîte à outils en mathématiques de la maternelle à la 4<sup>e</sup> année .....</b>	<b>22</b>
<b>Liste partielle de matériel de manipulation et de modèles - Maternelle à la 4<sup>e</sup> année .....</b>	<b>32</b>
<b>Sites Web offrant d'autres feuilles reproductibles .....</b>	<b>35</b>
<b>Sites Web offrant d'autres feuilles reproductibles disponibles uniquement en anglais .....</b>	<b>35</b>





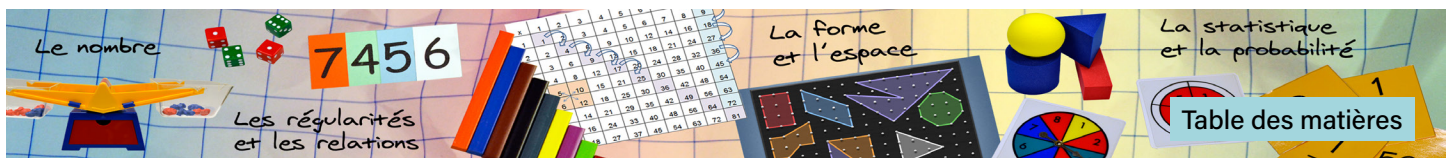

## Boîte à outils en mathématiques de la maternelle à la 4<sup>e</sup> année

### Des outils pour appuyer le raisonnement et l'apprentissage en mathématiques



#### Pourquoi une boîte à outils en mathématiques?

La boîte à outils en mathématiques sert à organiser les outils tels que des modèles et du matériel de manipulation qui sont utilisés régulièrement dans les classes de mathématiques pour aider l'élève à développer sa compréhension des concepts mathématiques, à résoudre des problèmes ou à participer à des jeux mathématiques. Des modèles tels que des tableaux de nombres, des droites numériques et des cartes numérotées ainsi que du matériel de manipulation tels que des dés, des jetons, des cubes et des règles peuvent faire partie de ces outils. Tous les élèves tireront profit d'une variété d'outils rangés au même endroit qui sont facilement accessibles et qu'ils peuvent apporter à la maison. L'objectif est de disposer d'un choix d'outils, à portée de la main, qui permet à l'élève de développer sa compréhension des concepts mathématiques par l'entremise de sept processus mathématiques, soit le raisonnement, la visualisation, la communication, la résolution de problèmes, le calcul mental et l'estimation, l'utilisation de la technologie et l'établissement de liens entre les concepts mathématiques ainsi qu'entre les mathématiques et leur quotidien. Ces processus mathématiques jouent un rôle crucial dans l'apprentissage, la compréhension et l'application des concepts mathématiques. Ils permettent à l'élève de reformuler, d'organiser, de travailler en réseau et de créer des images mentales pour mieux donner un sens à l'apprentissage et à l'application des concepts mathématiques. Ils s'incorporent à l'enseignement et à l'apprentissage des mathématiques; ce sont les véhicules par lesquels les concepts mathématiques se construisent.



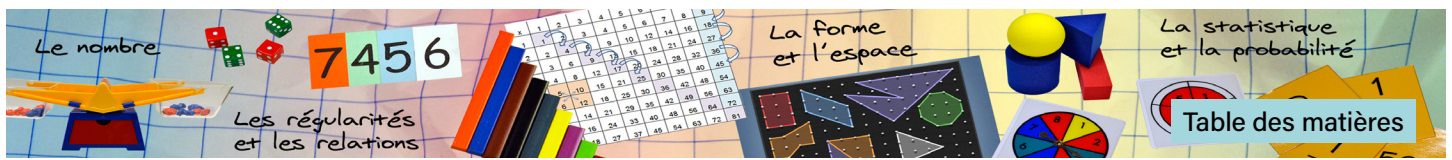

Pour que les boîtes à outils en mathématiques soient conviviales et utiles, on peut se servir de sacs ou de contenants transparents afin de donner à l'élève un accès immédiat aux outils qu'elles contiennent.



La composition de la boîte à outils dépend de l'enseignant et du profil de l'élève. Il serait préférable que chaque élève ait sa propre boîte à outils et que celle-ci soit conçue sur mesure pour mieux répondre à son profil d'apprenant en mathématiques. Celle-ci devrait être constituée d'outils incluant des modèles et du matériel de manipulation qui sont souvent utilisés en classe de mathématiques ou lors d'un enseignement portant sur des concepts particuliers. L'élève doit être conscient que la boîte à outils en mathématiques est une ressource qu'il peut utiliser en tout temps selon ses besoins.

Des dés, des cartes, des tableaux de nombres, des droites numériques et des tableaux blancs avec marqueurs effaçables sont des composantes essentielles de toute boîte à outils en mathématiques. Il est préférable de ne pas y placer tous les outils en même temps, mais plutôt de les insérer progressivement ou de les remplacer tout au long de l'année en fonction du concept enseigné. Par exemple, du matériel de manipulation comme des réglettes et des blocs mosaïques peut être placé dans le sac périodiquement. Peu importe les composantes de la boîte à outils, il est essentiel de :

- fournir un appui visuel illustrant chacun des outils accompagnés de leurs noms;
- laisser l'élève explorer les outils qui s'y retrouvent incluant une jasette mathématique au sujet de la façon dont on peut se servir des outils contenus dans leur boîte à outils selon le concept abordé;
- montrer à l'élève à se servir de certains des outils selon le concept abordé.
- 

Le contenu de la boîte à outils en mathématiques doit

- fournir des outils qui permettent à l'élève d'approfondir sa compréhension conceptuelle;
- favoriser l'autonomie chez l'élève en renforçant l'idée que le recours aux outils contribue à sa progression en résolution de problèmes et stimule sa réflexion et son raisonnement en mathématiques;
- permettre à l'élève de démontrer ses habiletés à représenter, à justifier et à noter son raisonnement et sa pensée lorsqu'il doit justifier les stratégies et les habiletés qu'il utilise pour résoudre un problème;
- permettre à l'élève d'établir des liens essentiels entre les représentations concrètes, imagées et symboliques des concepts mathématiques.

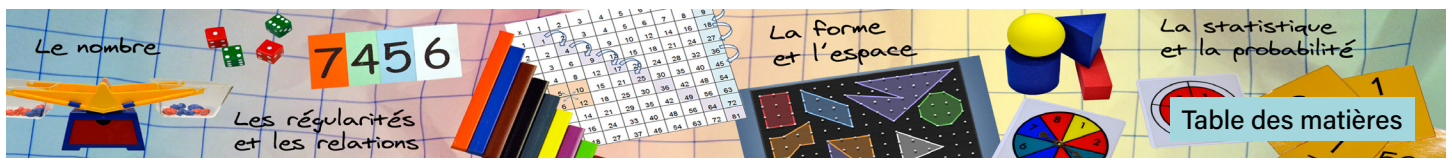

La gestion de la boîte à outils en mathématiques dépend de la salle de classe. Elle peut être rangée à proximité de l'élève, soit dans son pupitre, ou être suspendue à son pupitre, sa chaise ou sa table.

La boîte à outils peut contenir à la fois du matériel de manipulation, des modèles et du matériel fabriqué à la main. On peut acheter de nombreux articles à bas prix dans certains magasins ou auprès de fournisseurs de matériaux pédagogiques.



## Astuces suggérées

- Veillez à ce que la boîte à outils soit facilement accessible à l'élève.
- Utilisez des sacs et contenants en plastique durables.
- Renforcez les contours des sacs avec du ruban adhésif.
- Écrivez le nom de l'élève sur sa boîte à outils.
- Imprimez les feuilles reproductibles (FR) sur du papier cartonné et plastifiez-les.
- Lorsque vous présentez un outil, montrez différentes façons de l'utiliser et créez un tableau d'ancrage indiquant ces différentes façons.
- Si possible, préparez deux boîtes à outils pour chaque élève, soit une pour l'école et une autre pour la maison.
- Lorsqu'il apprend à distance, l'élève doit avoir sa boîte à outils à sa disposition.
- L'élève peut se servir des outils pour démontrer sa compréhension conceptuelle lorsqu'il travaille individuellement ou en petits groupes, ou durant l'enseignement à toute la classe.

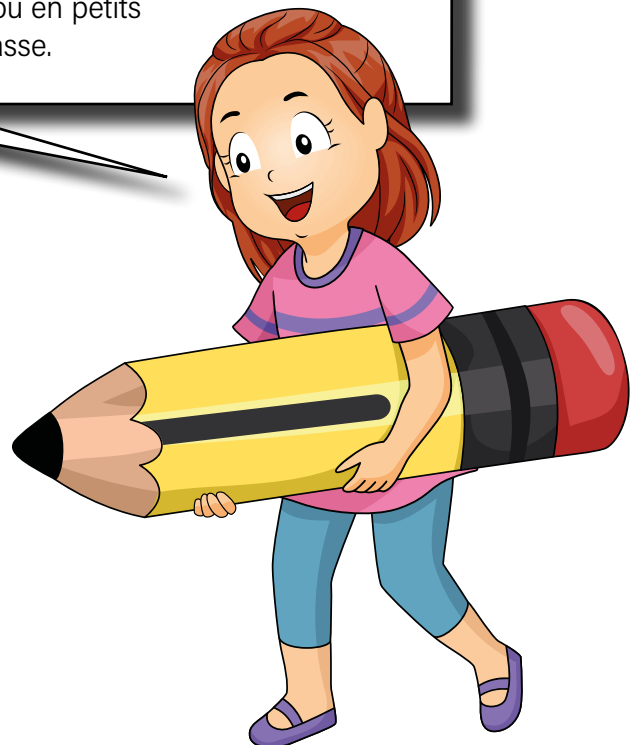





## Étiquettes pour les boîtes à outils en mathématiques

Les trois feuilles reproductibles (FR) ci-dessous peuvent servir d'étiquettes pour les boîtes à outils en mathématiques.

Étiquettes pour les boîtes à outils en mathématiques	
1	<p>Ma boîte à outils en mathématiques</p> <p>Mon nom : _____</p>
2	<p>Ma boîte à outils en mathématiques</p> <p>Mon nom : _____</p>
3	<p>Ma boîte à outils en mathématiques</p> <p>Mon nom : _____</p>

Demandez à l'élève de concevoir sa propre étiquette!



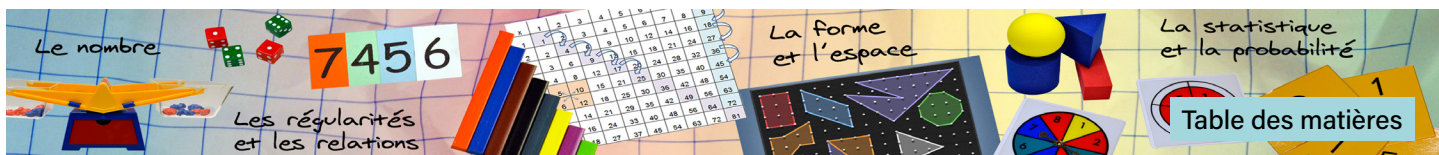

## Feuilles reproductibles (FR)

Certains outils proposés peuvent être créés à partir de feuilles reproductibles.

**NOTE :** Lorsque vous copiez des feuilles reproductibles à partir d'un hyperlien, réglez l'imprimante ou la photocopieuse selon les bons paramètres. Dans certains cas, vous devrez les imprimer en mode paysage. Selon l'imprimante ou la photocopieuse, vous pouvez imprimer sur du papier de différentes tailles, soit lettre (21,59 cm x 27,94 cm), légal (21,59 cm x 35,56 cm) ou tabloïde (27,94 cm x 43,18 cm). Chaque feuille reproductible fait l'objet d'un hyperlien à partir du document.

Les feuilles reproductibles ci-dessous, présentées en ordre alphabétique, peuvent être imprimées, plastifiées puis ajoutées à la boîte à outils de l'élève. Ce ne sont que des exemples, la liste n'étant pas exhaustive.

### Liste des feuilles reproductibles (FR)

#### Arrangement rectangulaire de points

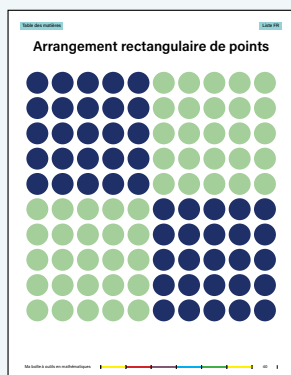

Les arrangements rectangulaires de points sont des modèles d'aire qui aident l'élève à visualiser les nombres et leurs relations, et à acquérir une compréhension de la relation partie-tout.

Ce sont des modèles d'aire à privilégier pour favoriser la compréhension de la multiplication, de la division, de la commutativité et de la distributivité.





## Balance

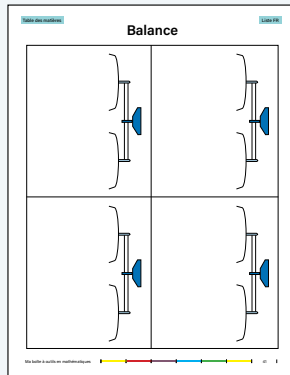

La feuille reproductible de la balance ne devrait pas être utilisée avant que l'élève ait eu de nombreuses occasions :

- d'utiliser des balances réelles pour acquérir une compréhension solide du concept d'égalité et d'inégalité;
- d'avoir des conversations mathématiques au sujet de ce qu'il remarque au sujet du concept de l'équilibre à la suite de à l'utilisation de la balance.

L'utilisation de la balance réelle permet à l'élève notamment de :

- construire deux ensembles égaux ou inégaux à l'aide du même type d'objets;
- représenter des égalités et des inégalités de façon concrète, et les noter symboliquement;
- démontrer l'égalité ou l'inégalité de deux ensembles;
- déterminer si deux ensembles concrets sont égaux ou inégaux;
- démontrer comment on peut modifier deux ensembles égaux à l'aide du même type d'objets pour obtenir des ensembles inégaux et vice versa;
- résoudre des équations d'addition et de soustraction;
- comparer et mesurer la masse de divers objets.

L'utilisation de la FR de la balance permet à l'élève notamment de :

- dessiner deux ensembles égaux ou inégaux à l'aide du même type d'objets;
- représenter des égalités et des inégalités de façon imagée, et les noter symboliquement;
- démontrer l'égalité ou l'inégalité de deux ensembles;
- modéliser comment on peut modifier deux ensembles égaux à l'aide du même type d'objets pour obtenir des ensembles inégaux et vice versa;
- résoudre des équations d'addition et de soustraction de façon imagée et symbolique.



### Bande numérique de 1 à 20

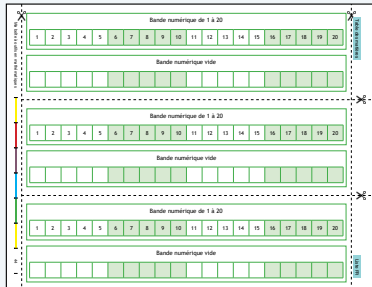

La comptine numérique renvoie à l'énumération orale de la séquence des nombres, la bande numérique est le support, écrit en chiffres, de cette même séquence. L'utilisation de la bande numérique est l'étape préalable à l'utilisation de la droite numérique.

Celle-ci présente des groupements ombragés de cinq éléments afin que l'élève commence à utiliser les points de repère 5, 10 et 20.

L'utilisation de la bande numérique permet à l'élève notamment de/d' :

- nommer le nombre qui est un de plus, deux de plus, un de moins ou deux de moins qu'un nombre donné jusqu'à 20;
- déterminer un ou des nombres manquants à l'intérieur d'une séquence de nombres ou entre deux points de repère;
- examiner et reconnaître des régularités numériques;
- ordonner et comparer des nombres;
- identifier le plus grand ou le plus petit nombre;
- établir des liens entre « avant », « plus petit que » et « moins que » de même qu'entre « après », « plus grand que » et « plus que »;
- effectuer des additions et des soustractions en comptant à partir d'un nombre.

### Blocs de base dix - représentation imagée

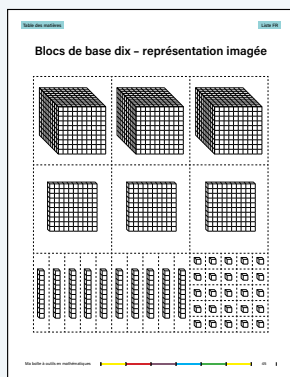

Les représentations imagées des blocs de base dix permettent à l'élève notamment de/d' :

- visualiser et représenter un nombre de diverses façons;
- acquérir une compréhension de la valeur de position;
- effectuer des opérations sur les nombres entiers et les nombres décimaux;
- établir des liens entre les nombres décimaux finis et les fractions.

**À noter :** Les modèles ne remplacent pas la manipulation des blocs de base dix. L'élève doit faire un lien entre les représentations concrètes (blocs de base dix), imagées (modèle de blocs de base dix) et symboliques des nombres à l'étude.

### Cartes à 5 points

#### Petit format

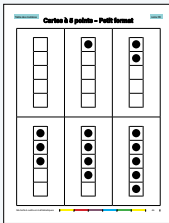

#### Grand format

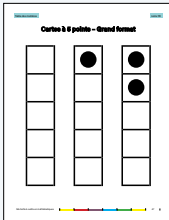

Les images des cartes à 5 points sont des modèles qui aident l'élève notamment à :

- associer un nombre, de 1 à 5, à la quantité qu'il représente;
- se faire une image mentale ou à visualiser les nombres de 1 à 5;
- acquérir une compréhension de la relation partie-partie-tout;
- acquérir une compréhension de la relation partie-tout;
- comparer et ordonner des quantités;
- établir une relation entre les nombres utilisés et le nombre repère 5;
- identifier les paires de nombres qui sont complémentaires de 5;
- résoudre des problèmes d'addition et de soustraction.

Les cartes à points vides utilisées avec des jetons permettent à l'élève de représenter concrètement les nombres.

### Cartes à 10 points – représentation imagée

#### Simple

#### Double

#### Vide

#### Petit format

#### Grand format

#### Petit format

#### Grand format

#### Horizontale

#### Verticale

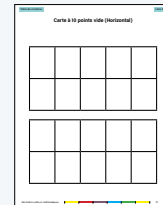
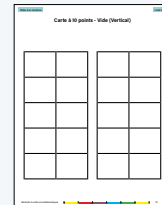
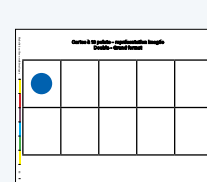
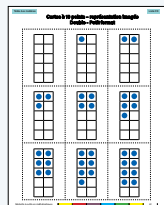
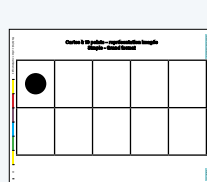
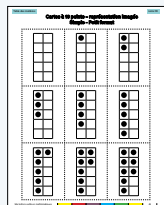

Les images des cartes à 10 points sont des modèles qui aident l'élève notamment à :

- associer un nombre, de 1 à 10, à la quantité qu'il représente;
- se faire une image mentale ou à visualiser différentes représentations des nombres;
- acquérir une compréhension de la relation partie-partie-tout;
- acquérir une compréhension de la relation partie-tout;
- comparer et ordonner des quantités;
- établir une relation entre les nombres utilisés et le nombre repère 10;
- identifier les paires de nombres qui sont complémentaires de 10;
- visualiser des stratégies de calcul mental;
- résoudre des problèmes d'addition et de soustraction.

Les cartes à points vides utilisées avec des jetons permettent à l'élève de représenter concrètement les nombres.

### Cartes de la partie manquante

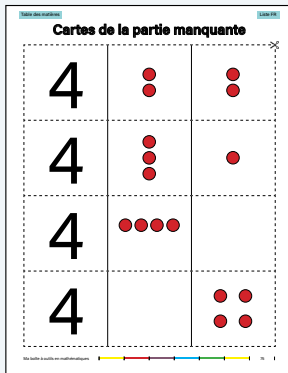

Basées sur une activité proposée par John Van de Walle, les cartes avec la partie manquante peuvent servir à la résolution de problèmes, à la compréhension de la relation partie-partie-tout et à la pratique de certains faits mathématiques.

L'élève reçoit le nombre représentant le tout sous forme symbolique et une des parties sous forme imagée; il doit alors, trouver la carte représentant la partie manquante.

On peut aussi remettre à l'élève une des rangées dont l'une des parties est recouverte d'un rabat. L'élève détermine la partie cachée ou manquante à partir du tout et de la partie visible.

### Cartes de nombres (0 à 100) et de symboles d'opération

#### Cartes de nombres (0 à 100)

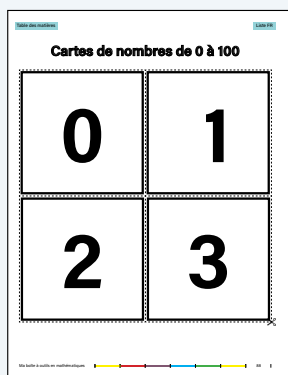

#### Cartes de symboles d'opération

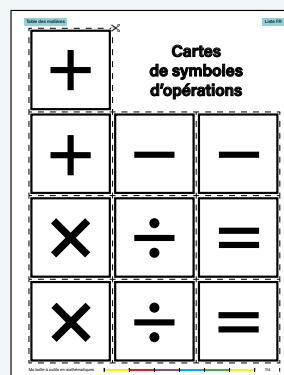

Les cartes de nombres et de symboles d'opérations peuvent être découpées et utilisées notamment pour :

- ordonner des nombres;
- créer des phrases mathématiques;
- créer des régularités numériques;
- participer à des jeux mathématiques.

Les cartes de nombres peuvent aussi être découpées et utilisées avec des cartes à points ou du matériel de manipulation pour appairer les représentations concrètes, imagées et symboliques des nombres.

### Cartes de reconnaissance globale avec les doigts de la main (1 à 10)

#### Carte en noir

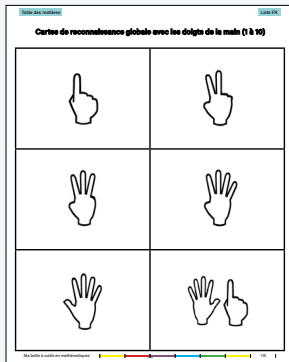

#### Carte en couleur

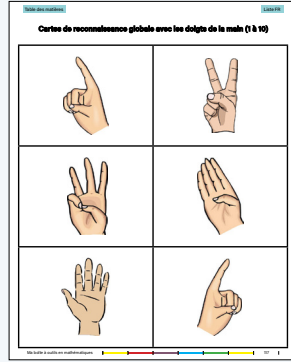

### Constellations de points familiers et non familiers (1 à 10)

#### Format rectangulaire

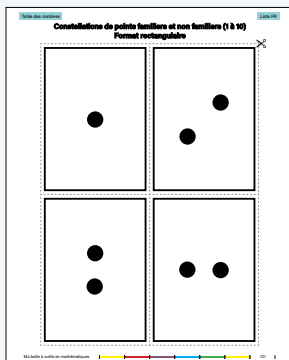

#### Format circulaire

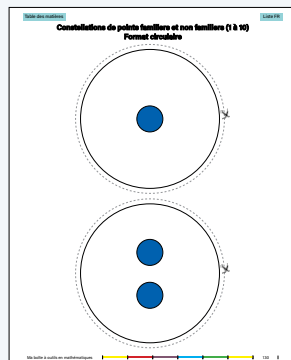

### Constellations de points familiers (1 à 6)

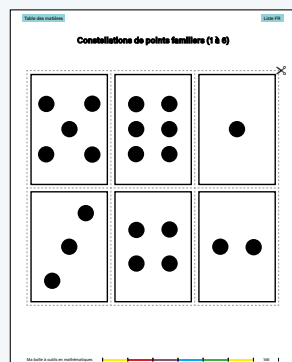

La reconnaissance globale est la capacité de déterminer rapidement la quantité d'un petit nombre d'objets sans les compter. Il y a deux types de reconnaissance globale :

- La reconnaissance globale perceptuelle est la capacité de reconnaître instantanément des arrangements familiers de 1 à 6 objets ou images afin d'en déterminer la quantité sans les compter, ce qui est la base du comptage et de la cardinalité.
- La reconnaissance globale conceptuelle consiste à percevoir des arrangements familiers à l'intérieur d'un ensemble (partie-partie-tout), puis à déterminer la quantité d'objets en regroupant ces arrangements. Par exemple, l'élève dit : « Il y a 5 points, j'ai vu 3 points bleus et 2 points rouges, donc 5 en tout ».

En utilisant différentes représentations spatiales, on donne à l'élève l'occasion de développer des images mentales qui pourront soutenir ses futurs apprentissages en mathématiques tels que l'addition et la soustraction.





### Cartes de représentations concrète et symbolique des nombres de 1 à 10

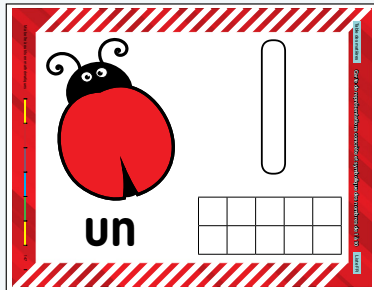

Coccinelle

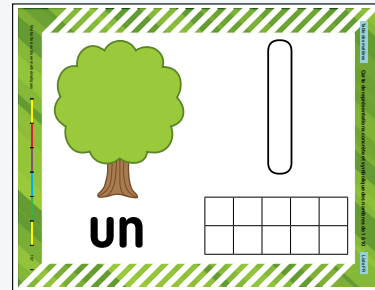

Arbre

L'élève place le nombre d'objets nécessaires (jetons, cailloux, feuilles, etc.) sur la carte à points pour représenter le nombre donné de façon concrète. Ceci permet à l'élève notamment de/d' :

- associer un nombre, de 1 à 10, à la quantité qu'il représente;
- se faire une image mentale ou visualiser différentes représentations des nombres;
- établir une relation entre les nombres utilisés et le nombre repère 10;
- comparer et ordonner des quantités et des nombres.

### Cartes de représentations imagée et symbolique des nombres

#### Appariements (1 à 10)

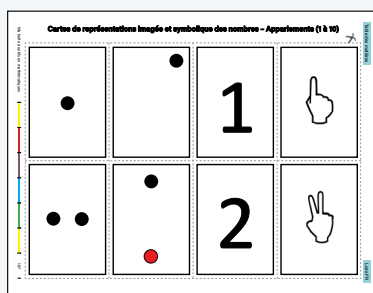

#### Chiffres et lettres (1-20)

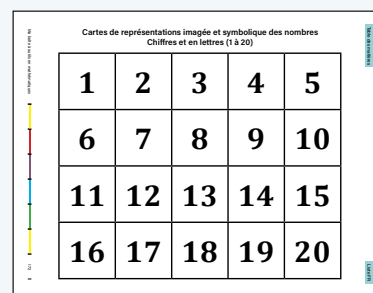

Un ensemble de cartes où figurent diverses représentations imagée et symbolique des nombres jusqu'à 10 permet à l'élève notamment de/d' :

- associer un nombre, de 1 à 10, à la quantité qu'il représente;
- se faire une image mentale ou visualiser différentes représentations des nombres;
- acquérir une compréhension de la relation partie-partie-tout;
- comparer et ordonner des quantités et des nombres.

Les cartes peuvent aussi être utilisées dans des jeux comme « À la pêche » et « Concentration ».

### Cartes de représentations imagée et symbolique des nombres jusqu'à 20

Trains ou tours de cubes

Petit format

Grand format

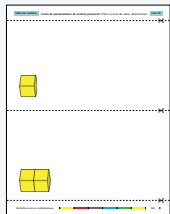
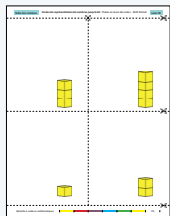

Arrangements de points

Petit format

Grand format

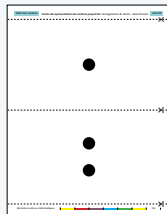
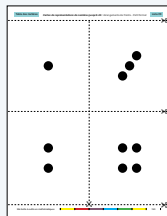

Nombres

Petit format

Grand format

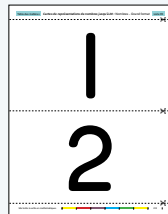
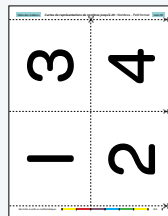

Boulier 2 x 10

Petit format

Grand format

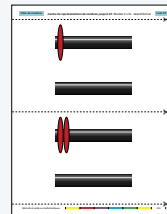
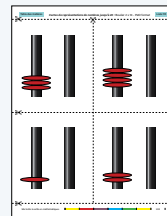

10 points

Petit format

Grand format

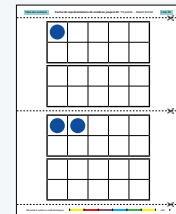
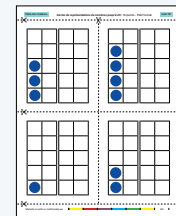

Doigts de deux paires de mains (1 à 20)

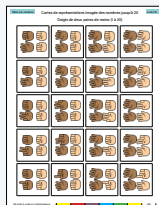

Doigts (0 à 20) avec nombres

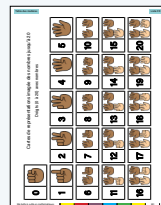

Doigts (1 à 20)

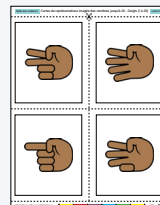

Doigts de deux paires de mains avec ou sans nombres de 0 à 20

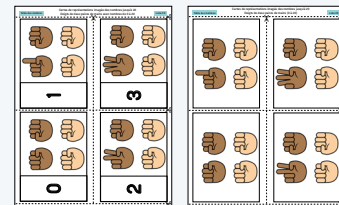

Un ensemble de cartes où figurent diverses représentations imagée et symbolique des nombres jusqu'à 20 permet à l'élève notamment de/d' :

- associer un nombre, de 1 à 20, à la quantité qu'il représente;
- se faire une image mentale ou visualiser différentes représentations des nombres;
- acquérir une compréhension de la relation partie-partie-tout;
- acquérir une compréhension de la relation partie-tout;
- comparer et ordonner des quantités et des nombres;
- établir une relation entre les nombres utilisés et les nombres repères 5 et 10;
- identifier les paires de nombres qui sont complémentaires de 20;
- visualiser des stratégies de calcul mental;
- créer ou résoudre des phrases numériques dont la somme ne dépasse pas 20, et leurs soustractions correspondantes.

Les cartes peuvent aussi être utilisées pour créer des jeux.



## Dé

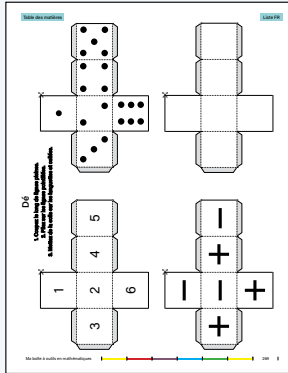

La feuille reproductible du dé peut être imprimée sur du papier cartonné, et utilisée dans des activités et des jeux mathématiques. Le dé en papier peut être placé dans la boîte à outils à emporter à la maison.

Les dés permettent à l'élève notamment de/d' :

- générer des nombres;
- créer des phrases mathématiques;
- jouer à des jeux mathématiques;
- reconnaître des arrangements de points familiers (reconnaissance globale);
- associer un nombre à la quantité qu'il représente;
- acquérir une compréhension de la relation partie-partie-tout (deux dés).

La fabrication du dé permet à l'élève de construire un cube à partir d'un de ses développements et d'entamer des conversations au sujet des caractéristiques du cube (faces, arêtes, sommets, etc.).

## Développements d'objets à trois dimensions

### Cube

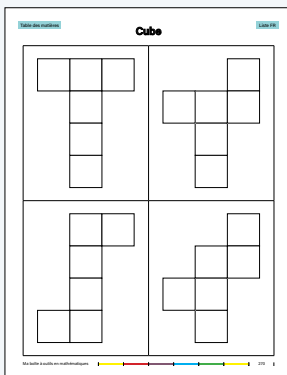

### Prisme à base rectangulaire

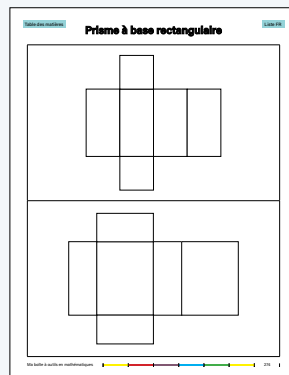

### Prisme à base triangulaire

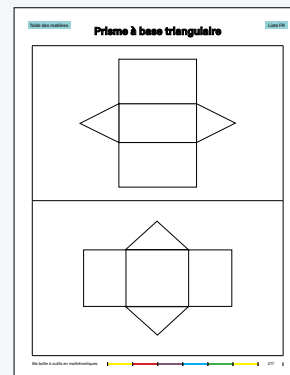

La fabrication d'objets à trois dimensions à partir de leurs développements permet à l'élève notamment de/d' :

- décrire les objets à trois dimensions selon leurs caractéristiques (faces, arêtes, sommets, etc.);
- comparer, trier et classer des objets à trois dimensions;
- associer les objets à trois dimensions à leur développement.

## Droites numériques

Horizontale de 0 à 100 avec graduations accentuées et chacun des nombres de 0 à 100

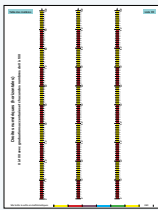

Horizontale de 0 à 100 avec graduations accentuées et nombres montrant les multiples de 10

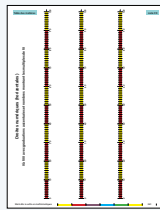

Horizontale vide avec graduations accentuées

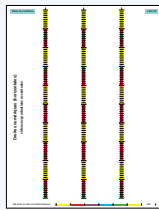

Horizontale vide avec nombre réduit de graduations accentuées

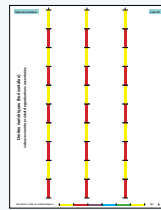

Horizontale ouverte

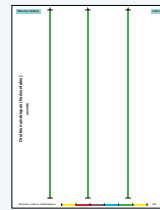

Horizontale avec points de repère variés

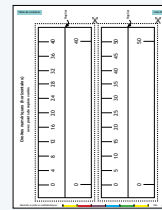

Verticale de 0 à 100 avec graduations accentuées et chacun des nombres de 0 à 100

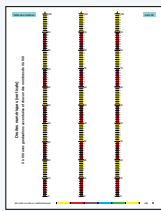

Verticale de 0 à 100 avec graduations accentuées et nombres montrant les multiples de 10

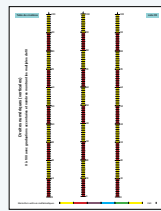

Verticale vide avec graduations accentuées

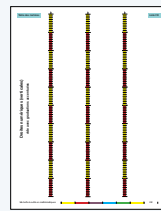

Verticale vide avec nombre réduit de graduations accentuées

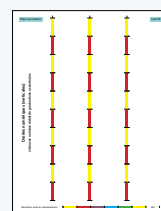

Verticale ouverte

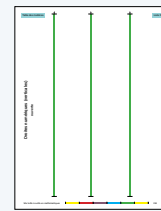

La droite numérique marque le passage du comptage d'objets à un modèle de longueur qui favorise le comptage par bonds et la visualisation des relations entre les nombres. L'élève doit construire et utiliser des droites numériques concrètes avant qu'on lui propose de les utiliser de façon imagée. Une droite numérique concrète peut être construite à l'aide d'une corde à billes ou de blocs emboîtables, p. ex.,

L'élève doit apprendre à faire des liens entre les nombres et la distance qu'ils représentent.

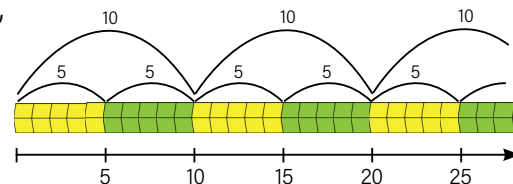

La droite numérique permet à l'élève notamment de/d' :

- comparer et ordonner des nombres entiers, des nombres décimaux et des fractions à l'aide de points de repères;
- résoudre des problèmes d'addition, de soustraction, de multiplication et de division;
- établir des liens entre la multiplication et l'addition répétée;
- établir des liens entre la division et la soustraction répétée;
- examiner des régularités.

**Ensemble de dominos  
(Total de points jusqu'à 12)**

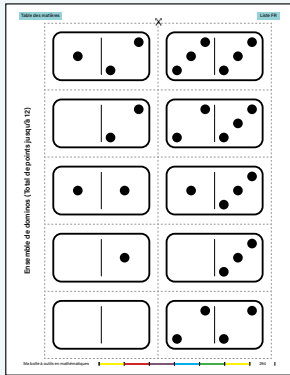

Les dominos permettent notamment de :

- susciter différentes images mentales des nombres;
- faciliter la reconnaissance globale conceptuelle d'arrangements de points familiers;
- créer des jeux qui invitent l'élève notamment à :
  - additionner et soustraire mentalement des nombres naturels jusqu'à 12 (p. ex., nombres repères 6 et 12, décomposition de nombres);
  - comprendre la relation partie-partie-tout;
  - établir une relation entre les nombres utilisés et les nombres repères 6 et 12;
  - comparer et ordonner des quantités;
  - décrire la famille de faits d'addition et de soustraction correspondants;
  - examiner, identifier et décrire des régularités.

**Ensemble de polygones**

**Réguliers**

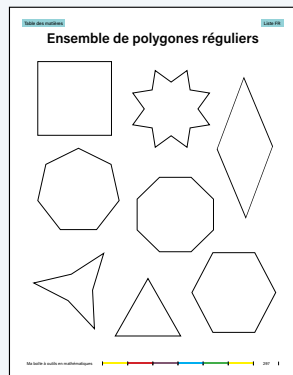

**Irréguliers**

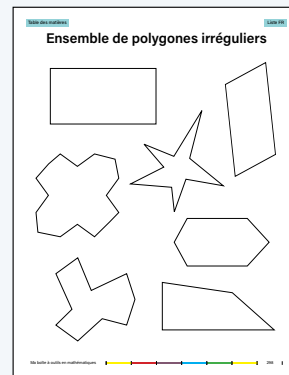

Les polygones peuvent être imprimés sur du papier cartonné puis découpés et plastifiés afin de créer un ensemble qui permet à l'élève notamment de :

- décrire et comparer des polygones;
- trier et classer des polygones.



## Éventails de nombres

### Éventail (0 à 9) avec décimales

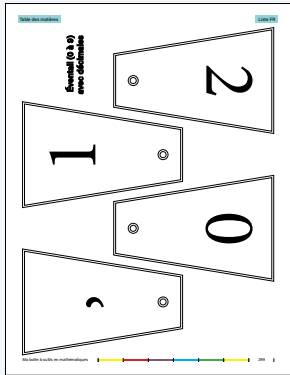

### Palette (0 à 9) avec décimales

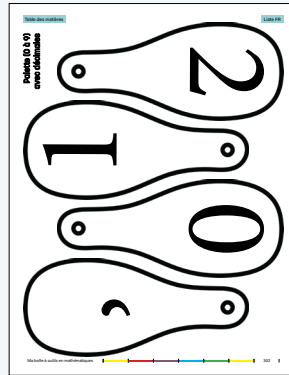

### Palette (0 à 10) de cartes à 10 points

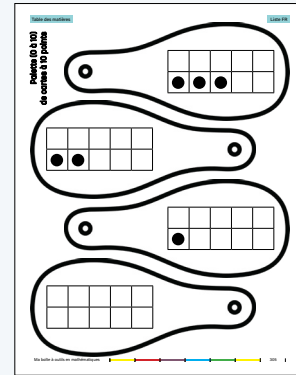

L'élève peut soumettre sa réponse à l'aide d'un éventail de nombres. Par exemple, on peut demander à l'élève de montrer :

- un nombre énoncé;
- le nombre avant et après le nombre énoncé;
- la réponse à un problème présenté sous la forme d'une histoire;
- la somme, la différence, le produit ou le quotient de deux nombres.

## Fiches de référence

### Bande numérique de 1 à 10 représentations imagée et symbolique

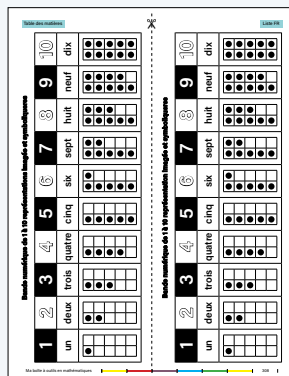

### Nombres en chiffres et en lettres

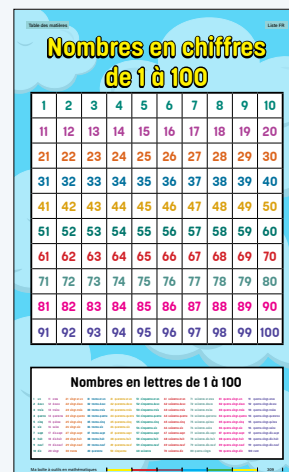

Ces feuilles reproductibles peuvent être utilisées comme fiches de référence.

## Fiches fractionnaires

### Bandes fractionnaires

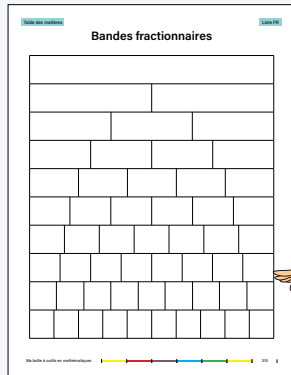

### Cercles fractionnaires

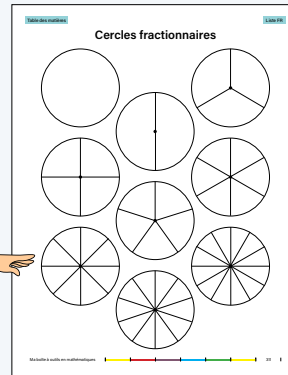

L'utilisation de cercles et de bandes fractionnaires permet à l'élève notamment de/d' :

- représenter des fractions;
- établir le lien entre le nom d'une fraction et sa représentation imagée et vice versa;
- explorer des modèles d'aire et de longueur;
- modéliser et expliquer la signification du numérateur et du dénominateur;
- comparer et ordonner des fractions.

## Les Roulettes

### Chiffres

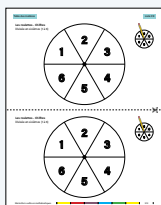

### Cartes à points

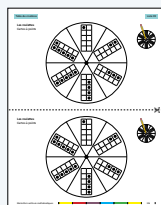

### Symboles d'opérations

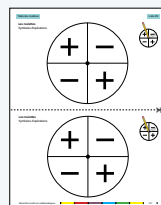

### Relations (+1, +2, -1, -2)

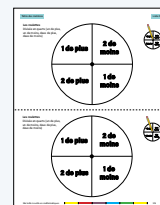

### Vide

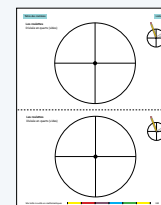

Les roulettes peuvent être imprimées sur du papier cartonné et utilisées dans des activités et des jeux mathématiques.

Les roulettes permettent à l'élève notamment de/d' :

- générer des nombres;
- créer des phrases mathématiques;
- jouer à des jeux mathématiques;
- reconnaître des arrangements de points familiers (reconnaissance globale);
- associer un nombre à la quantité qu'il représente;
- acquérir une compréhension de la relation partie-partie-tout (deux roulettes).



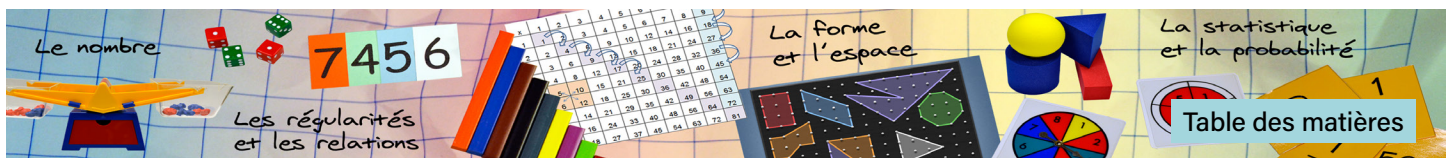

## Nombre du jour

### Maternelle

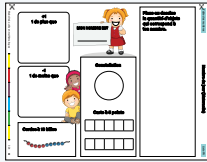

### 1<sup>re</sup> année

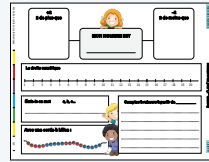

### 2<sup>e</sup> année

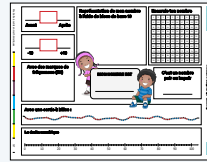

### 3<sup>e</sup> année

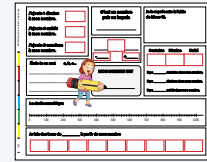

### 4<sup>e</sup> année

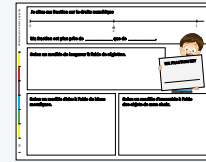

Le nombre du jour fait partie des routines mathématiques qui sont mises en place pour observer et évaluer l'élève au quotidien dans ses apprentissages en mathématiques. Ces routines sont structurées de façon à ne durer que quelques minutes seulement et à être répétées plusieurs fois par semaine. Les échanges mathématiques qu'elles suscitent permettent de développer des stratégies riches pour le calcul mental ainsi que la fluidité et la flexibilité en mathématiques. La routine *Le nombre du jour* peut être faite en groupe-classe, en petits groupes ou de façon individuelle. Afin de maximiser l'impact de la routine du nombre du jour, il est essentiel d'effectuer un retour en demandant à quelques élèves de présenter leurs représentations. Ceci permet aux élèves qui ont plus de difficulté d'élargir leur répertoire de représentations mathématiques.

La routine *Le nombre du jour* permet d'entamer des discussions sur les multiples façons de représenter un nombre à l'aide notamment de/d' :

- matériel de manipulation (cubes emboîtables, collections, réglettes, blocs de base 10, etc.) ou une représentation imagée de ce matériel;
- dés ou dessins de dés;
- dominos ou dessins de dominos;
- tableaux de nombres;
- cartes à points;
- arrangements de points;
- dessins;
- droites numériques, rubans à mesurer, etc.;
- exemples de la vie courante (une douzaine d'œufs, les minutes dans une heure, l'argent, etc.).

Il est aussi possible d'y intégrer certains concepts abordés en classe tels que :

- les opérations;
- la relation partie-partie-tout;
- les stratégies de calcul mental (un de plus que \_\_\_\_, un de moins que \_\_\_\_, etc.);
- les facteurs ou les multiples d'un nombre;
- la comparaison de nombres (plus grand que \_\_\_\_ ou plus petit que \_\_\_\_);
- les ordres croissant et décroissant (nombre qui vient avant ou après);
- les divers types de nombres (fractions, nombre décimal, etc.).

**À noter :** Il est aussi possible de s'inspirer de cette routine pour en créer d'autres dans divers domaines mathématiques : la figure à deux dimensions ou l'objet à trois dimensions du jour, la régularité du jour, le diagramme du jour, etc.

## Tableaux de nombres

1 à 20

1 à 30

1 à 100

0 à 99

100 vide

Quatre petits tableaux de 1 à 100

1 à 120

1 à 200

1 à 100 - du bas vers le haut

1 à 200 - du bas vers le haut

Générateur de tableaux de 100

<https://www.edu.gov.mb.ca/m12/progetu/ma/ressources.html>

Les tableaux de nombres aident les élèves notamment à :

- compter;
- compter par bonds;
- nommer le nombre qui est un de plus, dix de plus, un de moins ou cent de moins qu'un nombre donné;
- identifier des nombres;
- déterminer l'emplacement d'un nombre;
- déterminer un ou des nombres manquants à l'intérieur d'une séquence de nombres ou entre deux points de repère;
- identifier la séquence des nombres;
- examiner et reconnaître des régularités numériques;
- résoudre des problèmes.
- effectuer des additions et des soustractions.

Le générateur de tableaux de 100 en format Excel (<https://www.edu.gov.mb.ca/m12/progetu/ma/ressources.html>) permet de créer des tableaux de 100 qui commencent là où vous le désirez soit à 1, à 0, à 437 ou même à 3,5. Ce tableau se prête particulièrement bien aux activités reliées au développement d'habiletés de calcul mental (stratégie de « Compter par bonds », par exemple). Un mode d'emploi apparaît sous le générateur de tableaux.



## Valeur de position - Pochettes des valeurs de position (représentation symbolique)

### Centaine

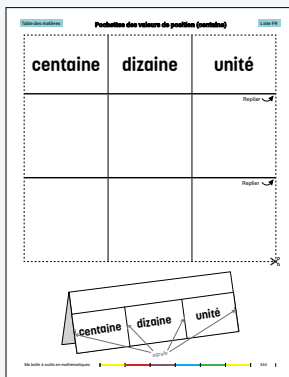

### Millier

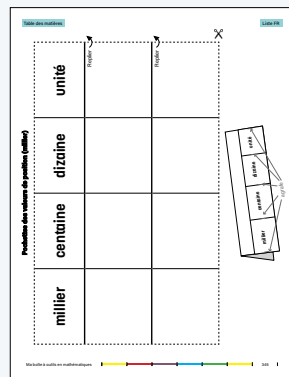

### Dizaine de millier

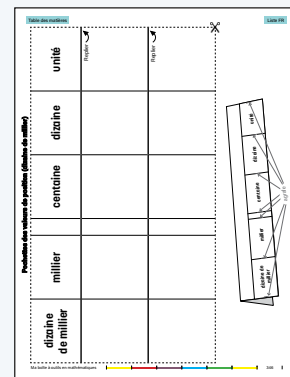

### Dixième

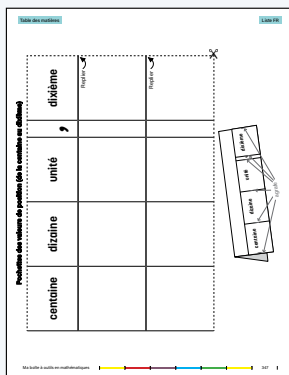

### Centième

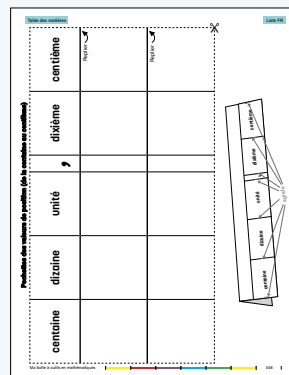

### Cartes de chiffres de 0 à 9

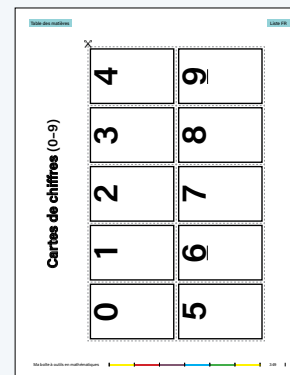

Les pochettes peuvent être utilisées après l'introduction de la valeur de position pour représenter les nombres de façon symbolique. Imprimez le nombre de cartes de chiffres (0 à 9) nécessaires pour composer les nombres à l'étude.

Pour fabriquer la pochette :

- découpez le long des lignes pointillées;
- repliez les termes indiquant la valeur de position;
- pliez sur la dernière ligne dans l'autre sens pour faire une tente;
- agrafez le long de toutes les lignes verticales.

Les pochettes des valeurs de position permettent à l'élève notamment de :

- représenter symboliquement un nombre énoncé en tenant compte de la valeur de position;
- représenter symboliquement le nombre qui a un de plus, une dizaine de plus, etc., que le nombre énoncé;
- donner la réponse à un problème présenté sous la forme d'une histoire.

### Valeur de position - Tapis des valeurs de position (représentations concrète, imagée et symbolique)

#### Vides

centaine 100	dizaine 10	unité 1

#### Imagés

centaine 100	dizaine 10	unité 1

#### Exemples

unité	dixième
$\frac{10}{10} = 1$	$\frac{1}{10}$ ou 0,1

Les tapis vides utilisés avec des blocs de base 10 ou du matériel construit par l'élève lui permettent de représenter les nombres à l'étude et d'effectuer des opérations de façon concrète.

Les tapis vides utilisés avec la FR *Blocs de base dix* permettent à l'élève de représenter les nombres à l'étude et d'effectuer des opérations de façon imagée.

Les tapis vides utilisés avec la FR *Cartes de chiffres de 0 à 9* permettent à l'élève de représenter les nombres à l'étude de façon symbolique.

### Valeur de position - Tentes de nombres jusqu'à 9999 (représentation symbolique)



Les tentes de nombres permettent à l'élève notamment de/d' :

- visualiser la relation entre les différentes valeurs de position;
- établir un lien entre la position qu'occupe un chiffre dans un nombre et sa valeur;
- composer et décomposer des nombres;
- représenter des nombres;
- effectuer des additions et des soustractions.

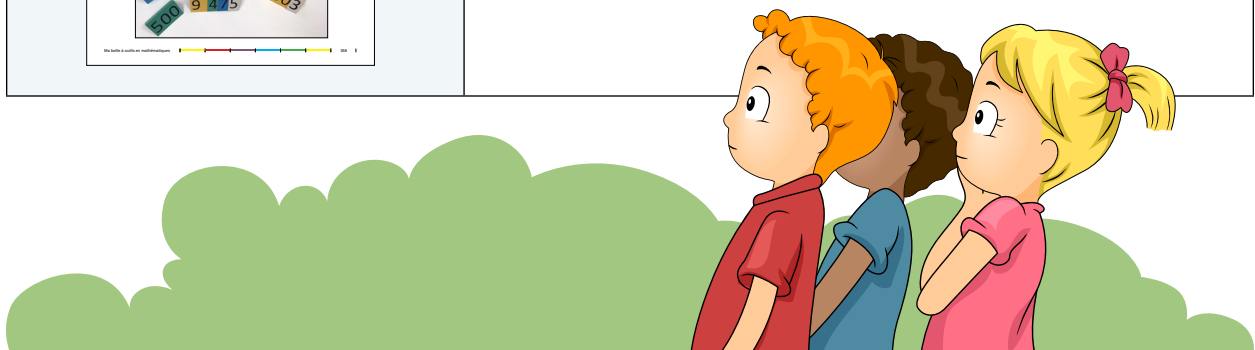

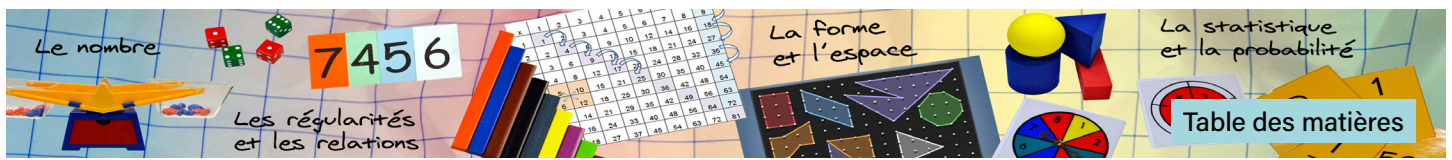

## Matériel de manipulation pour la boîte à outils en mathématiques de la maternelle à la 4<sup>e</sup> année

Le matériel de manipulation placé dans la boîte à outils de l'élève peut appuyer sa réflexion et ses apprentissages en mathématiques. La liste de matériel de manipulation, ci-dessous, présentée en ordre alphabétique, présente des exemples de matériel qui peut être ajouté à la boîte à outils de l'élève. Elle présente également les domaines et les apprentissages ciblés qui peuvent être abordés par l'entremise du matériel de manipulation dont il est question ainsi qu'une liste partielle d'utilisations de ce matériel. Ce ne sont que des exemples, la liste n'étant pas exhaustive.

On peut se procurer le matériel de manipulation présenté ci-dessous auprès de fournisseurs de matériel de mathématiques. On peut aussi se procurer de nombreux objets à bas prix dans les magasins à rayon.

### Tableau matériel de manipulation

#### Abaque, boulier ou corde à billes

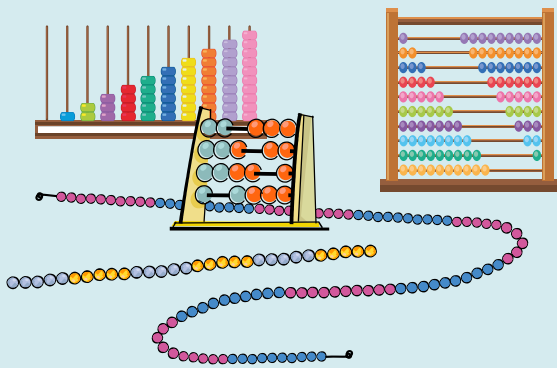

#### Domaines et apprentissages ciblés :

Le nombre

- Le comptage
- Les représentations des nombres entiers
- Les opérations avec des nombres entiers

La forme et l'espace

- La longueur

Ces représentations concrètes de la droite numérique peuvent être fabriquées par l'élève ou être achetées. Elles permettent à l'élève notamment de/d' :

- démontrer les relations entre les nombres (un de moins, un de plus, deux de moins, etc.);
- composer ou décomposer des nombres;
- associer un nombre à la quantité qu'il représente;
- acquérir une compréhension de la relation partie-partie-tout;
- identifier les paires de nombres qui sont complémentaires d'un nombre donné;
- comparer des quantités;
- établir une relation entre les nombres utilisés et les nombres repères 5, 10 et 20;
- effectuer des opérations;
- explorer la valeur de position;
- mesurer à l'aide d'unités de mesure non standards.

**À noter :** L'abaque étant un matériel non proportionnel il ne permet pas à l'élève de visualiser les relations qui existent entre les éléments de la base 10. Il est recommandé de ne pas l'utiliser avant que l'élève ait démontré une compréhension profonde des relations entre chacune des positions.

### Argent

(billets et pièces de monnaie)



#### Domaines et apprentissages ciblés :

Le nombre

- Les représentations des nombres entiers
- Les représentations des nombres rationnels (dixièmes et centièmes)
- Les opérations avec des nombres rationnels (addition/soustraction, limité aux centièmes)

Les régularités et les relations

- Les régularités et la pensée algébrique
- La forme et l'espace
- L'identification, le tri, la comparaison et la construction

**À noter :** L'argent est un matériel non proportionnel. Il est recommandé de ne pas l'utiliser avant la 2<sup>e</sup> année.

L'utilisation de l'argent permet à l'élève notamment de/d' :

- compter une somme d'argent jusqu'à 100 ¢;
- compter par bonds;
- effectuer des opérations sur les nombres décimaux;
- représenter une fraction d'un ensemble à l'aide de matériel concret;
- représenter des nombres décimaux;
- décrire, reproduire, prolonger et créer des régularités;
- trier des objets en se basant sur leurs caractéristiques.

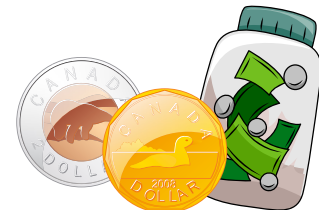

### Blocs logiques

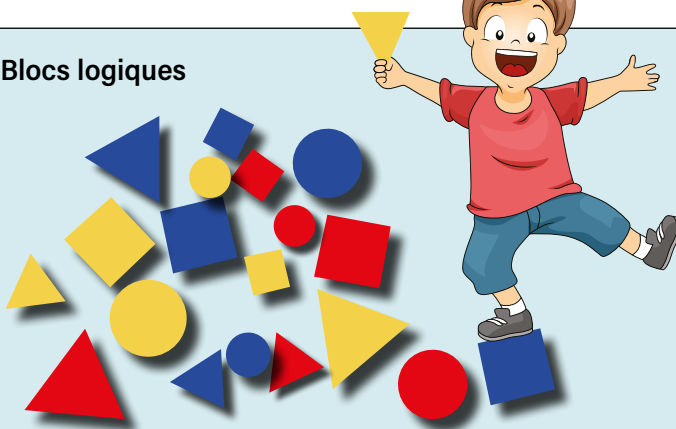

#### Domaines et apprentissages ciblés :

Les régularités et les relations

- Les régularités et la pensée algébrique

La forme et l'espace

- L'identification, le tri, la comparaison et la construction

L'utilisation des blocs logiques permet à l'élève notamment de/d' :

- décrire, reproduire, prolonger et créer des régularités;
- nommer et reconnaître des figures géométriques;
- identifier des attributs et leurs caractéristiques;
- trier selon les caractéristiques ou les attributs.



### Blocs mosaïques

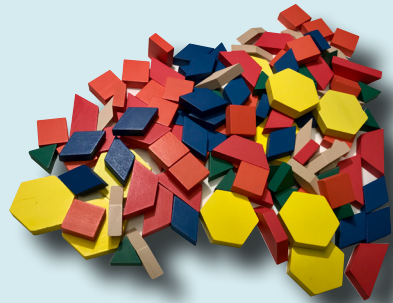
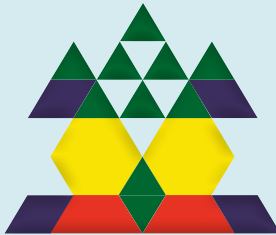

L'utilisation des blocs mosaïques permet à l'élève notamment de :

- représenter des fractions;
- décrire, reproduire, prolonger et créer des régularités;
- mesurer une aire à l'aide d'unités non standards.

### Domaines et apprentissages ciblés :

Le nombre

- Les représentations des nombres rationnels

Les régularités et les relations

- Les régularités et la pensée algébrique

La forme et l'espace

- L'aire
- L'identification, le tri, la comparaison et la construction

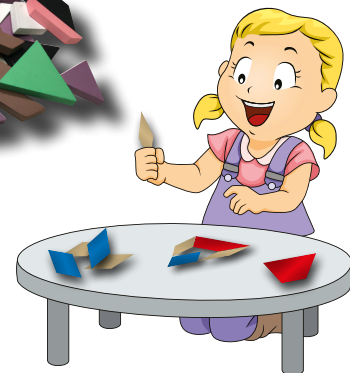
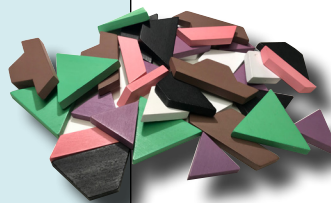

### Calculatrice



L'utilisation de la calculatrice permet à l'élève notamment d'utiliser la fonction facteur constant pour rechercher des régularités.

### Domaines et apprentissages ciblés :

Les régularités et les relations

- Les régularités et la pensée algébrique

### Cartes à jouer

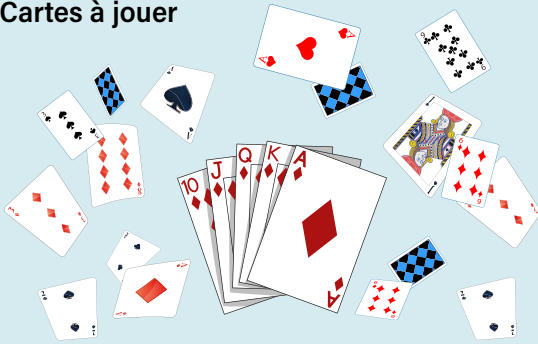

#### Domaines et apprentissages ciblés :

##### Le nombre

- Le comptage
- Les représentations des nombres entiers
- Les opérations avec des nombres entiers

##### Les régularités et les relations

- Les régularités et la pensée algébrique

##### La forme et l'espace

- La longueur
- L'aire
- L'identification, le tri, la comparaison et la construction

Les cartes à jouer permettent notamment de :

- susciter différentes images mentales des nombres;
- faciliter la reconnaissance globale conceptuelle d'arrangements de points familiers;
- créer des jeux qui invitent l'élève notamment à :
  - additionner et soustraire mentalement des nombres naturels jusqu'à 10 (p. ex., nombres repères 5 et 10, décomposition de nombres);
  - comprendre la relation partie-partie-tout;
  - établir une relation entre les nombres utilisés et les nombres repères 5 et 10;
  - comparer et ordonner des quantités;
  - mesurer la longueur et l'aire à l'aide d'unités non standards;
  - décrire la famille de faits d'addition et de soustraction correspondants;
  - décrire, reproduire, prolonger et créer des régularités;
  - trier selon les caractéristiques ou les attributs.

### Cercles et bandes fractionnaires

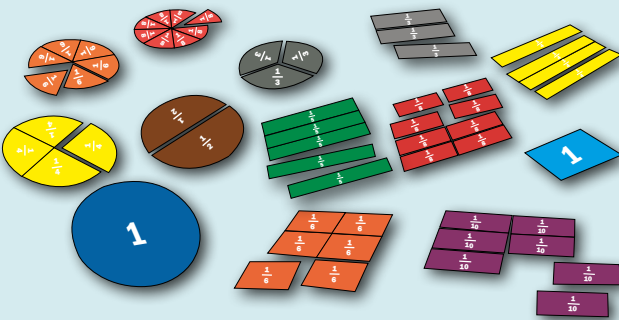

#### Domaines et apprentissages ciblés :

##### Le nombre

- Les représentations des nombres rationnels

L'utilisation des cercles et des bandes fractionnaires permet à l'élève notamment de/d' :

- représenter des fractions;
- établir le lien entre le nom d'une fraction et sa représentation concrète et vice versa;
- explorer des modèles d'aire et de longueur;
- modéliser et expliquer la signification du numérateur et du dénominateur;
- comparer et ordonner des fractions.

**Collection** - Objets de formes, de tailles et de couleurs variées (jetons de bingo, jetons bicolores, boutons, fèves, petits ours, blocs, bouchons, tuiles, etc.)



**Domaines et apprentissages ciblés :**

Le nombre

- Le comptage
- Les représentations des nombres entiers
- Les représentations des nombres rationnels
- Les opérations avec des nombres entiers

Les régularités et les relations

- L'identification, le tri, la comparaison et la construction

L'utilisation de diverses collections permet à l'élève notamment de/d' :

- déterminer des quantités;
- démontrer une compréhension de la correspondance biunivoque;
- construire et comparer des ensembles d'objets;
- composer et décomposer des nombres;
- effectuer des opérations;
- estimer des quantités;
- identifier et représenter des fractions d'un ensemble;
- modéliser et comprendre que, dans certains cas, deux fractions identiques ne représentent pas une même quantité (p. ex., un demi de dix boutons n'est pas équivalent à la moitié de seize boutons);
- construire et interpréter des diagrammes concrets;
- décrire, reproduire, prolonger, transposer et créer des régularités;
- trier des objets en se basant sur leurs caractéristiques.

**Cubes emboîtables**

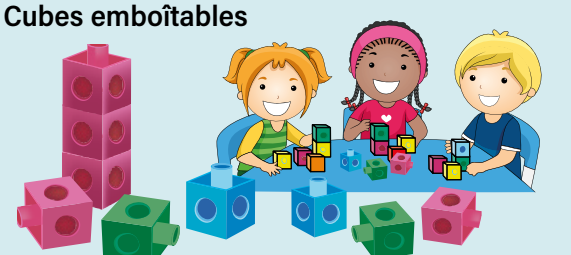

**Domaines et apprentissages ciblés :**

Le nombre

- Le comptage
- Les représentations des nombres entiers
- Les opérations avec des nombres entiers

Les régularités et les relations

- Les régularités et la pensée algébrique

La forme et l'espace

- La longueur

L'utilisation des cubes emboîtables permet à l'élève notamment de/d' :

- déterminer des quantités;
- démontrer une compréhension de la correspondance biunivoque;
- construire et comparer des ensembles d'objets;
- composer et décomposer des nombres;
- effectuer des opérations;
- estimer des quantités;
- identifier et représenter des fractions d'un ensemble;
- construire et interpréter des diagrammes concrets;
- décrire, reproduire, prolonger, transposer et créer des régularités;
- mesurer une aire à l'aide d'unités non standards.



### Dés (cubes de nombres)

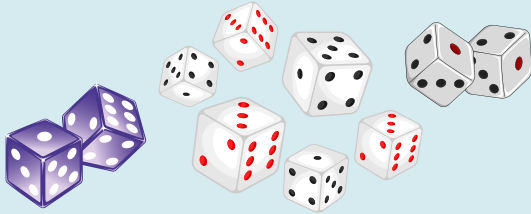

#### Domaines et apprentissages ciblés :

Le nombre

- Le comptage
- Les représentations des nombres entiers
- Les opérations avec des nombres entiers

Les dés permettent à l'élève notamment de/d' :

- générer des nombres;
- créer des phrases mathématiques;
- jouer à des jeux mathématiques;
- reconnaître des arrangements de points familiers (reconnaissance globale);
- associer un nombre à la quantité qu'il représente;
- acquérir une compréhension de la relation partie-partie-tout (deux dés).

### Dominos



#### Domaines et apprentissages ciblés :

Le nombre

- Les représentations des nombres entiers
- Les opérations avec des nombres entiers

Les régularités et les relations

- Les régularités et la pensée algébrique

Les dominos permettent notamment de :

- susciter différentes images mentales des nombres;
- faciliter la reconnaissance globale conceptuelle d'arrangements de points familiers;
- créer des jeux qui invitent l'élève notamment à :
  - additionner et soustraire mentalement des nombres naturels jusqu'à 10 (p. ex., nombres repères 5 et 10, décomposition de nombres);
  - comprendre la relation partie-partie-tout;
  - établir une relation entre les nombres utilisés et les nombres repères 5 et 10;
  - comparer et ordonner des quantités;
  - décrire la famille de faits d'addition et de soustraction correspondants;
  - examiner, identifier et décrire des régularités.

**Matériel de base 10**

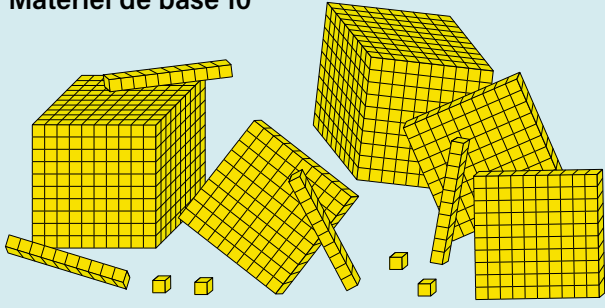

**Domaines et apprentissages ciblés :**

Le nombre

- Le comptage
- Les représentations des nombres entiers
- Les représentations des nombres rationnels
- Les opérations avec des nombres entiers
- Les opérations avec des nombres rationnels (addition/soustraction de nombres décimaux)

La forme et l'espace

- La longueur

On peut insérer des blocs de base 10 pour les élèves qui ont une bonne compréhension de la valeur de position. Pour l'apprentissage préalable à la valeur de position, il est recommandé d'utiliser des objets comme les cartes à 10 points, des bâtons de bricolage ou des blocs emboîtables.

Le matériel de base 10 permet à l'élève notamment de/d' :

- compter par bonds;
- représenter des nombres;
- effectuer des opérations;
- établir des relations entre les nombres décimaux et les fractions (dixièmes, centièmes);
- composer et décomposer des nombres;
- estimer et mesurer des longueurs.

**Géoplan**

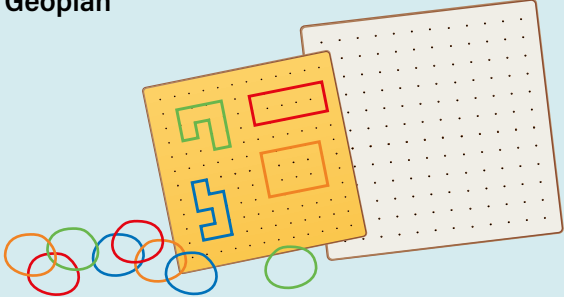

**Domaines et apprentissages ciblés :**

Le nombre

- Les opérations avec des nombres entiers (multiplication/division)
- Les représentations des nombres rationnels

La forme et l'espace

- La longueur
- L'aire
- Les objets à trois dimensions et les figures à deux dimensions

L'utilisation de géoplans permet à l'élève notamment de/d' :

- représenter des figures à deux dimensions;
- déterminer l'aire et le périmètre de figures à deux dimensions;
- construire des figures à deux dimensions dont le périmètre, l'aire ou les deux sont connus;
- établir la relation entre l'aire et le périmètre de certaines figures;
- représenter et comparer des fractions;
- établir des liens entre l'aire et la multiplication.

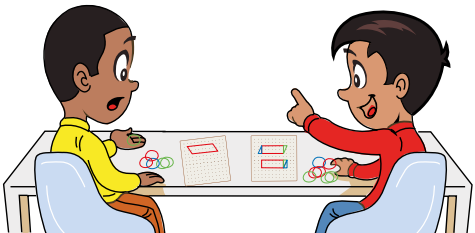

### Horloge



**Domaines et apprentissages ciblés :**

La forme et l'espace

- Le temps

L'utilisation d'horloges permet à l'élève notamment de/d' :

- lire et noter l'heure en utilisant des horloges numériques et des horloges analogiques, y compris des horloges de 24 heures;
- mesurer le temps;
- établir des relations entre les unités de mesure de temps.

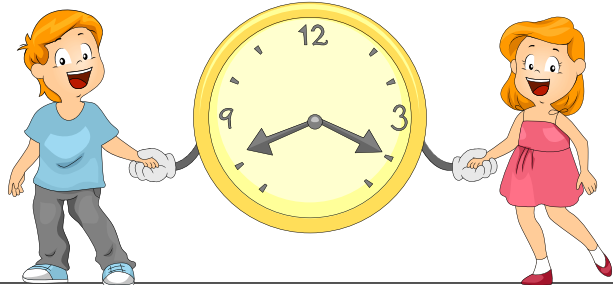

### Règle, ruban à mesurer, corde, ficelle, bout de laine, chaînon, trombone

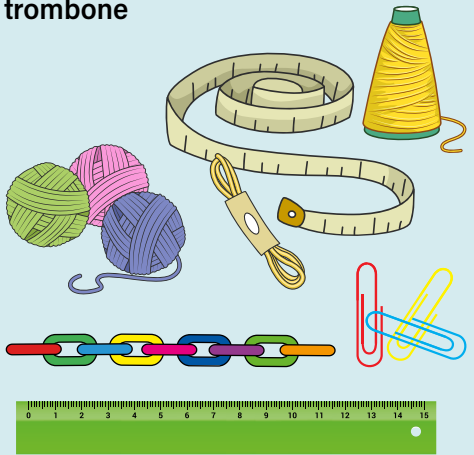

**Domaines et apprentissages ciblés :**

La forme et l'espace

- La longueur

L'utilisation de règles ou de rubans à mesurer permet à l'élève notamment de/d' :

- effectuer des mesures à l'aide d'unités standards;
- comparer des longueurs;
- établir des relations entre les unités de mesure de longueur.

L'utilisation de cordes, ficelles, bouts de laine, chaînons, trombones, etc., permet à l'élève notamment de/d' :

- effectuer des mesures à l'aide d'unités non standards;
- comparer des longueurs;
- établir des relations entre les unités de mesure de longueur.

### Réglattes

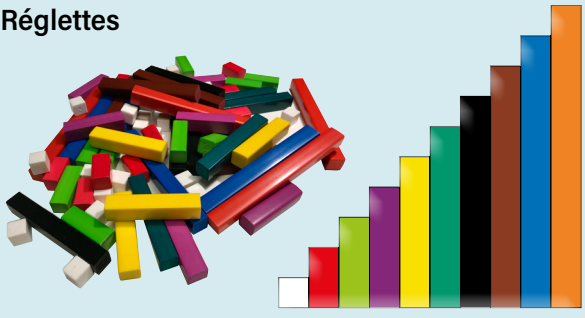

**Domaines et apprentissages ciblés :**

Le nombre

- Les représentations des nombres entiers
- Les représentations des nombres rationnels
- Les opérations avec des nombres entiers

Les régularités et les relations

- Les relations algébriques à l'aide d'équations

La forme et l'espace

- La longueur

L'utilisation de réglattes permet à l'élève notamment de/d' :

- représenter et comparer des nombres;
- effectuer des opérations;
- développer le sens de la fraction;
- représenter, comparer et ordonner des fractions;
- résoudre des équations d'addition et de soustraction;
- mesurer et estimer des longueurs à l'aide d'unités non standards et standards.

### Tangram

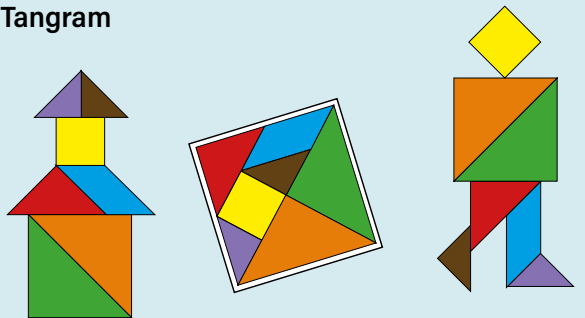

**Domaines et apprentissages ciblés :**

Le nombre

- Les représentations des nombres rationnels

La forme et l'espace

- Les objets à trois dimensions et les figures à deux dimensions
- L'identification, le tri, la comparaison et la construction

L'utilisation du Tangram permet à l'élève notamment de/d' :

- aborder les fractions;
- identifier des figures à deux dimensions;
- compléter des casse-têtes géométriques.



**Tuiles de couleur**

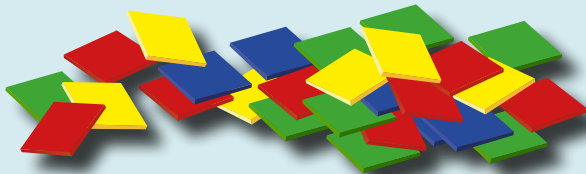

**Domaines et apprentissages ciblés :**

Le nombre

- Le comptage
- Les représentations des nombres entiers
- Les représentations des nombres rationnels
- Les opérations avec des nombres entiers

Les régularités et les relations

- Les régularités et la pensée algébrique

La forme et l'espace

- La longueur
- L'aire

L'utilisation des tuiles de couleurs permet à l'élève notamment de/d' :

- représenter et comparer des nombres;
- décrire, reproduire, prolonger, transposer et créer des régularités;
- établir des liens entre l'aire et la multiplication;
- représenter et comparer des fractions;
- déterminer l'aire et le périmètre de figures à deux dimensions à l'aide d'unités non standards;
- construire des figures à deux dimensions dont le périmètre, l'aire ou les deux sont connus;
- établir la relation entre l'aire et le périmètre de certaines figures.

**Trombones ou maillons de chaînettes de couleurs différentes**

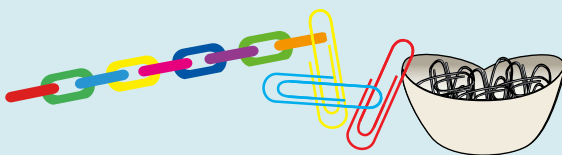

**Domaines et apprentissages ciblés :**

Le nombre

- Le comptage
- Les représentations des nombres entiers
- Les représentations des nombres rationnels
- Les opérations avec des nombres entiers

Les régularités et les relations

- Les régularités et la pensée algébrique

La forme et l'espace

- La longueur
- Les objets à trois dimensions et les figures à deux dimensions
- L'identification, le tri, la comparaison et la construction

L'utilisation des trombones ou maillons de chaînettes permet à l'élève notamment de/d' :

- démontrer une compréhension de la correspondance biunivoque;
- déterminer, estimer et comparer des quantités;
- établir des liens entre les nombres et les quantités qu'ils représentent;
- composer et décomposer des nombres;
- effectuer des opérations;
- déterminer, représenter et comparer des fractions d'un ensemble;
- décrire, reproduire, prolonger, transposer et créer des régularités;
- estimer et mesurer des longueurs à l'aide d'unités non standards;
- trier des objets en se basant sur leurs caractéristiques.





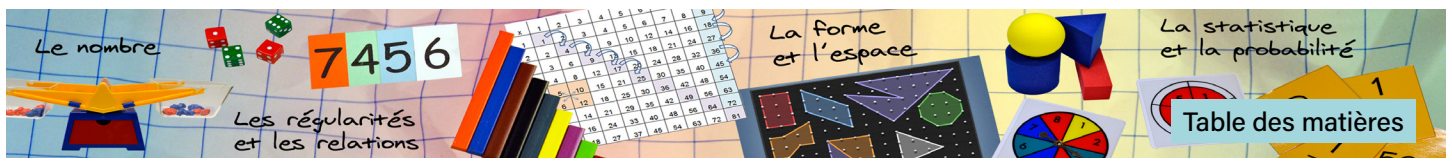





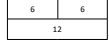

## Liste partielle de matériel de manipulation et de modèles - Maternelle à la 4<sup>e</sup> année

Les cartes de routes de la maternelle à la 4<sup>e</sup> année proposent une [Liste partielle de matériel de manipulation](#) pour chaque niveau scolaire. Elles présentent également de nombreuses façons d'en tirer profit, et ce, dans tous les domaines mathématiques à l'étude.

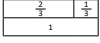
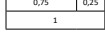
Maternelle	1 <sup>re</sup> année	2 <sup>e</sup> année	3 <sup>e</sup> année	4 <sup>e</sup> année
<ul style="list-style-type: none"> <li>Bac à sable ou bac à eau</li> <li>Balance</li> <li>Bandes de nombres cachés</li> <li>Blocs logiques</li> <li>Blocs mosaïques</li> <li>Cartes à 5 et à 10 points</li> <li>Cubes emboîtables/cubes Unifix</li> <li>Dés</li> <li>Dominos</li> <li>Jetons</li> <li>Objets à 3 dimensions</li> <li>Réglettes Cuisenaire</li> <li>Roulettes</li> <li>Tuiles de couleur</li> <li>Variété de collections</li> </ul> 	<ul style="list-style-type: none"> <li>Balance</li> <li>Bandes de nombres cachés</li> <li>Bâtonnets géométriques</li> <li>Blocs logiques</li> <li>Blocs mosaïques</li> <li>Dés, dominos</li> <li>Géoplans</li> <li>Objets à 3 dimensions</li> <li>Réglettes Cuisenaire</li> <li>Roulettes</li> <li>Tableau de 100</li> <li>Tuiles de couleur</li> <li>Variété de collections</li> </ul> 	<ul style="list-style-type: none"> <li>Balance</li> <li>Bandes de nombres cachés</li> <li>Bâtonnets géométriques</li> <li>Blocs de base 10</li> <li>Blocs logiques</li> <li>Blocs mosaïques</li> <li>Cubes emboîtables/cubes Unifix</li> <li>Dés, dominos</li> <li>Cartes de polygones réguliers et irréguliers</li> <li>Objets à trois dimensions</li> <li>Géoplans</li> <li>Réglettes Cuisenaire</li> <li>Roulettes</li> <li>Tuiles de couleur</li> <li>Variété de collections</li> </ul> 	<ul style="list-style-type: none"> <li>Balance</li> <li>Bandes de nombres cachés</li> <li>Bâtonnets géométriques</li> <li>Blocs de base dix</li> <li>Blocs logiques</li> <li>Blocs mosaïques</li> <li>Cartes de polygones réguliers et irréguliers</li> <li>Cubes emboîtables/cubes Unifix</li> <li>Dés, dominos</li> <li>Géoplans</li> <li>Objets à trois dimensions</li> <li>Pièces de monnaie et billets</li> <li>Règles</li> <li>Réglettes Cuisenaire</li> <li>Roulettes</li> <li>Tuiles de couleur</li> <li>Variété de collections</li> </ul> 	<ul style="list-style-type: none"> <li>Balance</li> <li>Bandes de nombres cachés</li> <li>Bâtonnets géométriques</li> <li>Blocs de base 10</li> <li>Blocs logiques</li> <li>Blocs mosaïques</li> <li>Cartes de polygones réguliers et irréguliers</li> <li>Cubes emboîtables/cubes Unifix</li> <li>Dés, dominos</li> <li>Géoplans</li> <li>MIRA</li> <li>Objets à trois dimensions</li> <li>Pièces de monnaie et billets</li> <li>Règles</li> <li>Réglettes Cuisenaire</li> <li>Roulettes</li> <li>Tuiles de couleur</li> <li>Variété de collections</li> </ul>
<ul style="list-style-type: none"> <li>Calendrier</li> <li>Tableau « partie-partie-tout »</li> <li>Reconnaissance globale : carte de nombres (1 à 10), carte à points, constellation, carte de doigts, dé</li> <li>Variété de droites numériques (horizontale et verticale, ouverte et fermée)</li> <li>Dénombrement : corde à billes, abaque</li> </ul>	<ul style="list-style-type: none"> <li>Base dix : carte à 10 points, corde à billes</li> <li>Calendrier</li> <li>Carte de nombres (1 à 100)</li> <li>Dénombrement et calcul : corde à billes, abaque, tableau de nombres, carte à points simple et double</li> <li>Reconnaissance globale : carte à points, constellation, dé, domino</li> <li>Tableau « partie-partie-tout »</li> </ul>  <p>Variété de droites numériques (horizontale et verticale, ouverte et fermée)</p>	<ul style="list-style-type: none"> <li>Base dix : carte à 10 points, tapis de valeur de position, tente de nombres jusqu'à 100</li> <li>Calendrier</li> <li>Calcul : corde à billes, abaque, tableau de nombres, carte à points simple et double</li> <li>Carte de nombres (1 à 100)</li> <li>Tableau « partie-partie-tout »</li> </ul>  <p>Variété de droites numériques (horizontale et verticale, ouverte et fermée)</p>	<ul style="list-style-type: none"> <li>Base dix : carte à 10 points, tapis de valeur de position, tente de nombres jusqu'à 1000</li> <li>Calcul : tableau de nombres, carte à points simple et double, variété de droites numériques (horizontale et verticale, ouverte et fermée)</li> <li>Carte de nombres (1 à 1000)</li> <li>Tableau de nombres</li> <li>Tableau partie-partie-tout</li> </ul> 	<ul style="list-style-type: none"> <li>Base dix : blocs de base dix, tapis de valeur de position, tentes de nombres jusqu'à 10 000</li> <li>Calcul : arrangement rectangulaire, tableau de nombres, variété de droites numériques (horizontale et verticale, ouverte et fermée)</li> <li>Fraction : carte à 10 points, carte de fractions et modèles de région, de mesure (longueur et volume) ou d'ensemble</li> <li>Tableau de nombres</li> <li>Tableau « partie-partie-tout »</li> </ul> 

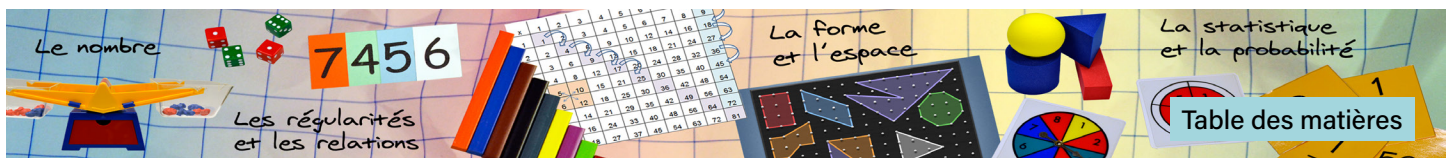

Bien que ce matériel soit disponible dans la salle de classe, il peut s'avérer impossible de le fournir individuellement à chacun des élèves. Des outils virtuels peuvent toutefois être utilisés lorsque l'élève comprend bien l'utilisation du matériel de manipulation dont il est question. Ces outils virtuels ne remplacent pas le matériel de manipulation, ils le complètent.

Le tableau qui suit présente une liste d'outils virtuels gratuits tirés de *Mathies Learning Tools* et *Math Learning Center*. Ce ne sont que des exemples, la liste n'étant pas exhaustive.

**Note :** Plusieurs de ces outils d'apprentissage numériques sont écrits en Adobe Flash et publiés au format .swf et ne sont plus disponibles depuis la fin de 2020. Elles peuvent toutefois être téléchargées afin de les rendre accessibles aux différents utilisateurs. Certaines des ressources numériques mathématiques les plus récentes sont disponibles sous une forme qui ne nécessite pas Flash. Veuillez consulter le site Mathies Home régulièrement pour prendre connaissance des mises à jour.

Matériel de manipulation virtuel	Mathies Learning Tools <a href="https://mathies.ca/francais.php">https://mathies.ca/francais.php</a> <a href="https://www.mathies.ca/learningTools.php#Cc0">https://www.mathies.ca/learningTools.php#Cc0</a>	Math Learning Center <a href="http://www.mathlearningcenter.org/apps">www.mathlearningcenter.org/apps</a>
Arrangement rectangulaire		<a href="https://apps.mathlearningcenter.org/partial-product-finder/">https://apps.mathlearningcenter.org/partial-product-finder/</a>
Argent canadien	<a href="https://mathclips.ca/swfPlayer.html?swfURL=tools/Notepad1.swf&amp;title=Bloc-notes&amp;language=fr">https://mathclips.ca/swfPlayer.html?swfURL=tools/Notepad1.swf&amp;title=Bloc-notes&amp;language=fr</a>	
Blocs de base dix		<a href="https://www.mathlearningcenter.org/resources/apps/number-pieces">https://www.mathlearningcenter.org/resources/apps/number-pieces</a>
Blocs mosaïques	<a href="https://mathclips.ca/swfPlayer.html?swfURL=tools/PatternBlocks1.swf&amp;title=Blocs%20mosa%C3%AFques%20g%C3%A9om%C3%A9triques%2B&amp;language=fr">https://mathclips.ca/swfPlayer.html?swfURL=tools/PatternBlocks1.swf&amp;title=Blocs%20mosa%C3%AFques%20g%C3%A9om%C3%A9triques%2B&amp;language=fr</a>	<a href="https://www.mathlearningcenter.org/apps/pattern-shapes">https://www.mathlearningcenter.org/apps/pattern-shapes</a>
Boulier	<a href="https://mathclips.ca/swfPlayer.html?swfURL=tools/Rekenrek1.swf&amp;title=Rekenrek&amp;language=fr">https://mathclips.ca/swfPlayer.html?swfURL=tools/Rekenrek1.swf&amp;title=Rekenrek&amp;language=fr</a>	<a href="https://www.mathlearningcenter.org/resources/apps/number-rack">https://www.mathlearningcenter.org/resources/apps/number-rack</a>
Calculatrice	<a href="https://mathclips.ca/calculator.html?mode=basic">https://mathclips.ca/calculator.html?mode=basic</a>	
Cartes à 5 et 10 points, et grille de 100	<a href="https://mathclips.ca/swfPlayer.html?swfURL=tools/Set1.swf&amp;title=L%27outil%20%27ensemble&amp;language=fr">https://mathclips.ca/swfPlayer.html?swfURL=tools/Set1.swf&amp;title=L%27outil%20%27ensemble&amp;language=fr</a>	<a href="https://www.mathlearningcenter.org/apps/number-frames">https://www.mathlearningcenter.org/apps/number-frames</a>



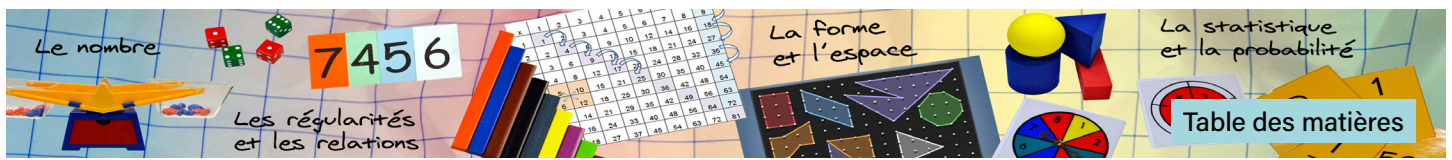

Cercles et bandes fractionnaires	<a href="https://mathclips.ca/swfPlayerhtml?swfURL=tools/ColourTiles1.swf&amp;title=Tuiles%20de%20couleur&amp;language=fr">https://mathclips.ca/swfPlayerhtml?swfURL=tools/ColourTiles1.swf&amp;title=Tuiles%20de%20couleur&amp;language=fr</a>	<a href="https://www.mathlearningcenter.org/resources/apps/fractions">https://www.mathlearningcenter.org/resources/apps/fractions</a>
Droite numérique		<a href="https://www.mathlearningcenter.org/resources/apps/number-line">https://www.mathlearningcenter.org/resources/apps/number-line</a>
Géoplan		<a href="https://www.mathlearningcenter.org/resources/apps/geoboard">https://www.mathlearningcenter.org/resources/apps/geoboard</a>
Horloge		<a href="https://www.mathlearningcenter.org/resources/apps/math-clock">https://www.mathlearningcenter.org/resources/apps/math-clock</a>
Bloc-notes (Mathies Learning Tools offre une variété d'arrière-plan.)	<a href="https://mathclips.ca/swfPlayer.html?swfURL=tools/Notepad1.swf&amp;title=Bloc-notes&amp;language=fr">https://mathclips.ca/swfPlayer.html?swfURL=tools/Notepad1.swf&amp;title=Bloc-notes&amp;language=fr</a>	<a href="https://www.mathlearningcenter.org/apps/whiteboard-app">https://www.mathlearningcenter.org/apps/whiteboard-app</a>
Réglettes	<a href="https://mathclips.ca/swfPlayer.html?swfURL=tools/RelationalRods1.swf&amp;title=R%26eacute%3Bglettes%2B&amp;language=fr">https://mathclips.ca/swfPlayer.html?swfURL=tools/RelationalRods1.swf&amp;title=R%26eacute%3Bglettes%2B&amp;language=fr</a>	
Tableau de nombres, table d'addition et de multiplication	<a href="https://mathies.ca/tools/NumberChart/index.html?show=true&amp;title=Tableau%20des%20nombres&amp;language=fr">https://mathies.ca/tools/NumberChart/index.html?show=true&amp;title=Tableau%20des%20nombres&amp;language=fr</a>	
Tuiles de couleur	<a href="https://mathclips.ca/swfPlayer.html?swfURL=tools/ColourTiles1.swf&amp;title=Tuiles%20de%20couleur&amp;language=fr">https://mathclips.ca/swfPlayer.html?swfURL=tools/ColourTiles1.swf&amp;title=Tuiles%20de%20couleur&amp;language=fr</a>	

Autres outils virtuels offerts gratuitement (ce ne sont que des exemples, la liste n'étant pas exhaustive.)

- Les applications *TouchCounts* et *TouchTimes* permettent à l'élève d'utiliser le toucher (doigt), le visuel (yeux) et l'auditif (oreilles) pour apprendre à compter, additionner, soustraire et multiplier. <http://www.touchcounts.ca/index-fr.html>
- L'application *120 secondes* permet à l'élève de jouer contre la montre. Il a l'occasion de pratiquer ses faits de bases pour les 4 opérations de base. <https://apps.apple.com/fr/app/120s/id1335092533> et <https://play.google.com/store/apps/details?id=com.mmultimaths.A120s>
- L'application *Fin Lapin*, offert par Alloprof, est un jeu interactif où l'élève doit réaliser différentes épreuves. Il devra répondre à des questions de calcul et il pourra alors pratiquer ses faits de base. <http://www.alloprof.qc.ca/Jeux/finlapin/>

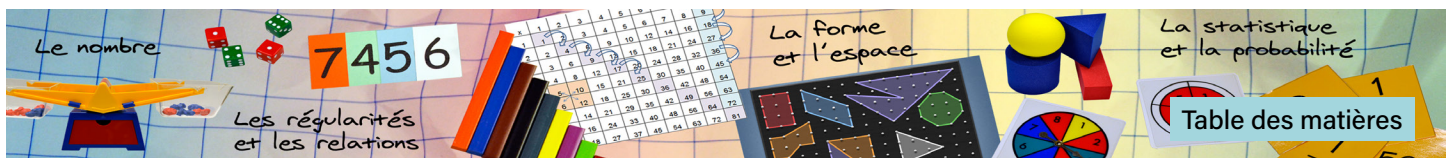

- L'application *123-Compte* et *Trace* aide l'élève à apprendre les nombres, à les tracer, à compter et bien plus encore. Elle est conçue pour que l'élève et les parents jouent ensemble. <https://apps.apple.com/ca/app/123-nombres-compte-et-trace/id1210356444?l=fr>
- L'application *Jeu de Maths : Jeu préscolaire* est un jeu éducatif gratuit, conçu pour enseigner à compter et comparer des nombres ainsi qu'à additionner et soustraire des nombres. <https://apps.apple.com/ca/app/jeu-de-maths-jeux-pr%C3%A9scolaire/id1466931283?l=fr&mt=12>



### Sites Web offrant d'autres feuilles reproductibles

Les sites suivants proposent d'autres éléments que vous pouvez placer dans la trousse d'outils selon vos besoins. Les articles peuvent être copiés et plastifiés.

- <http://cybersavoir.csdm.qc.ca/123/materiel-de-manipulation-au-1er-cycle/>
- [http://lrt.ednet.ns.ca/PD/BLM\\_Fr/table\\_des\\_matières.htm](http://lrt.ednet.ns.ca/PD/BLM_Fr/table_des_matières.htm)
- Si vous avez fait l'achat d'un des livres *L'enseignement des mathématiques — L'élève au centre de son apprentissage* de Van de Walle, John A. et LouAnn H. Lovin. (2007), veuillez communiquer avec un représentant de Pearson Canada pour avoir accès aux fiches reproductibles en français



### Sites Web offrant d'autres feuilles reproductibles disponibles uniquement en anglais

- [www.nzmaths.co.nz/numeracy/materialmasters.aspx](http://www.nzmaths.co.nz/numeracy/materialmasters.aspx)
- [www.sparklebox.co.uk/maths/](http://www.sparklebox.co.uk/maths/)







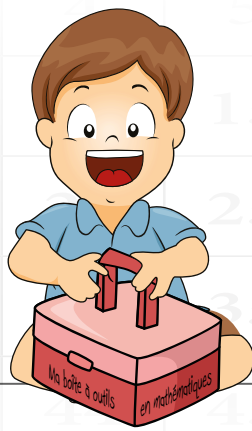

# Ma boîte à outils en mathématiques

Mon nom : \_\_\_\_\_

Étiquette 1

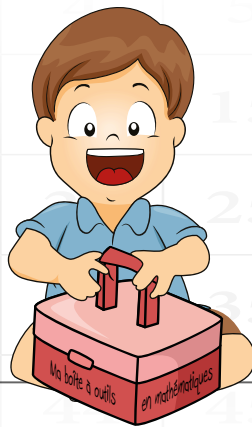

# Ma boîte à outils en mathématiques

Mon nom : \_\_\_\_\_



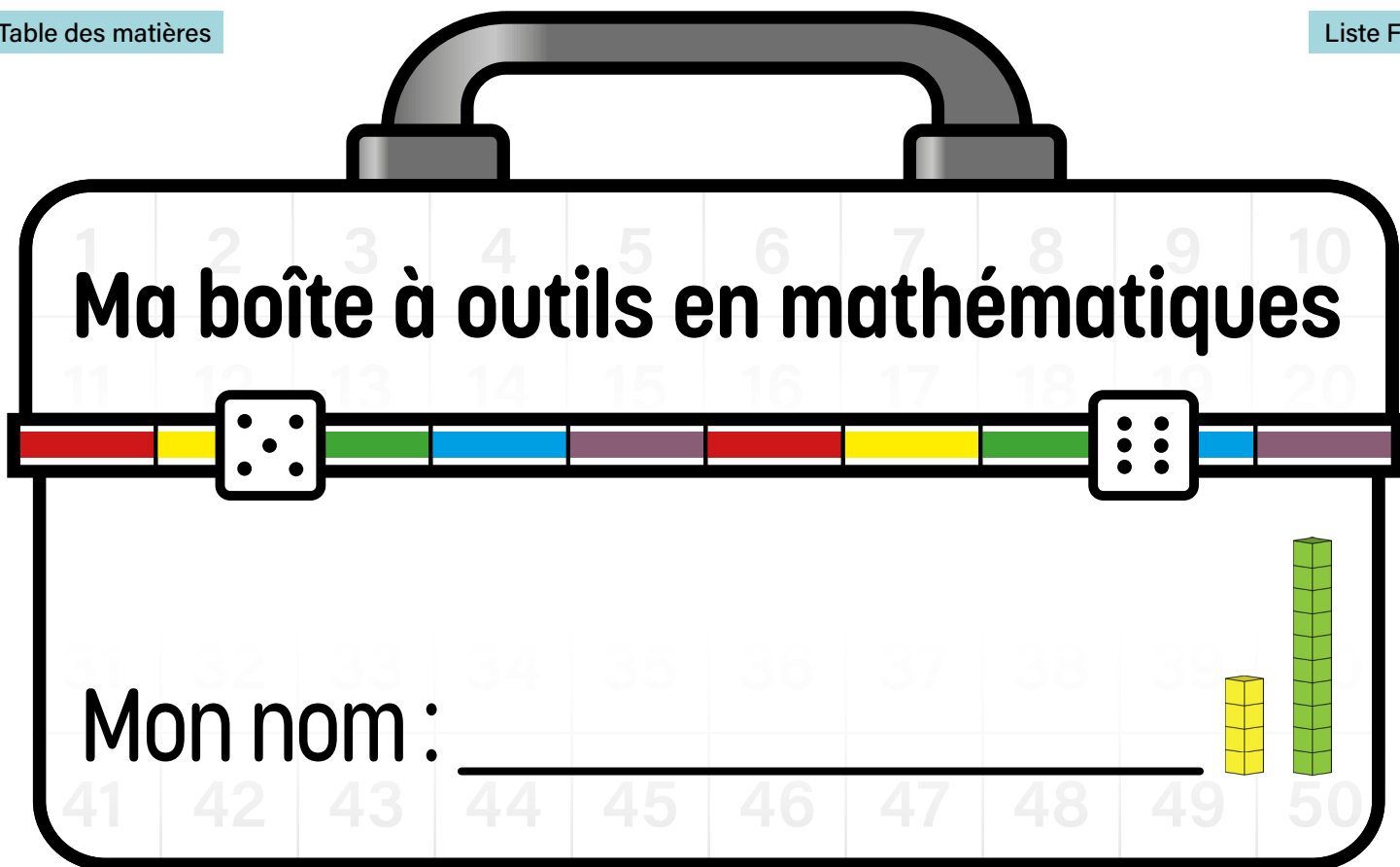

Étiquette 2

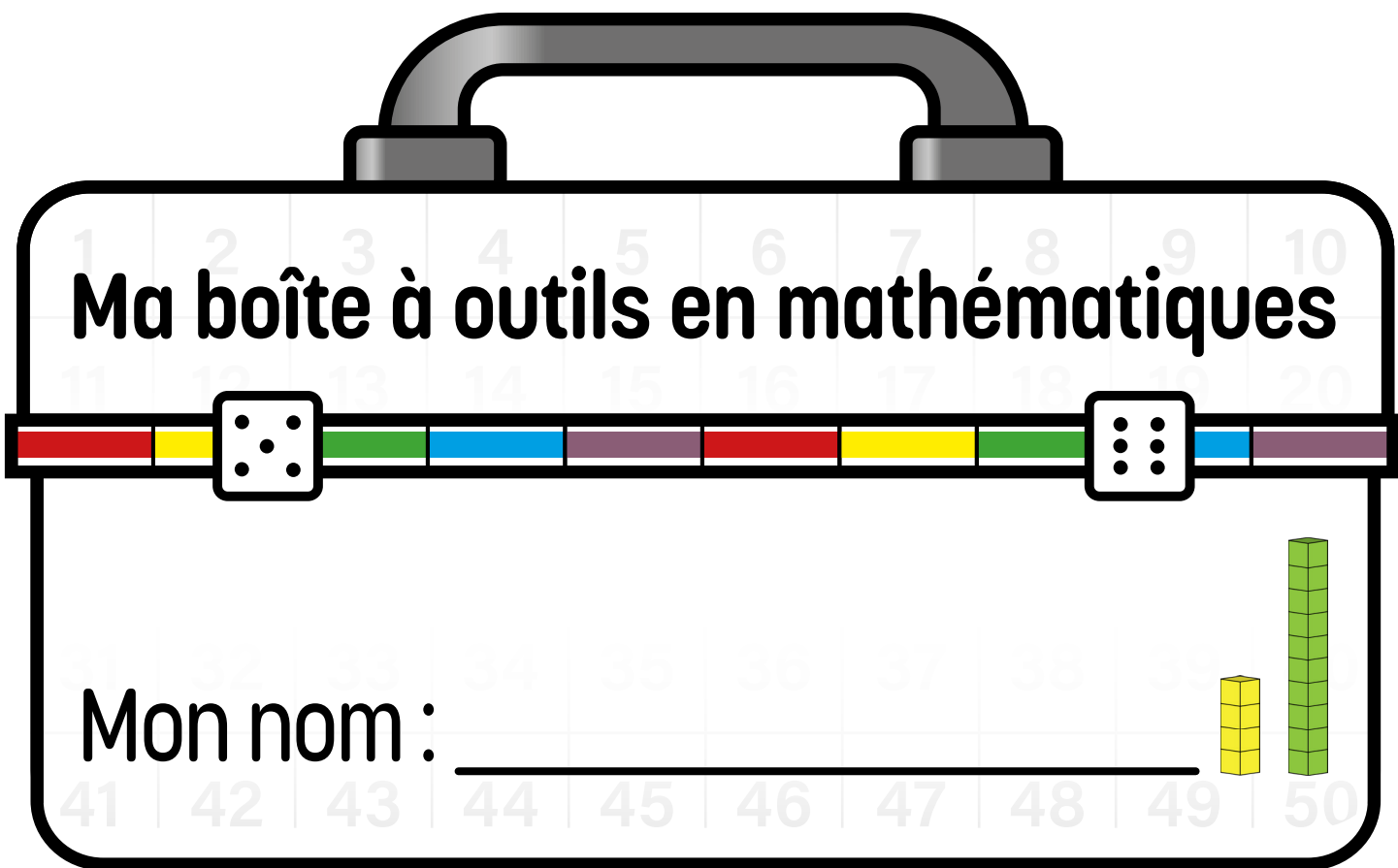

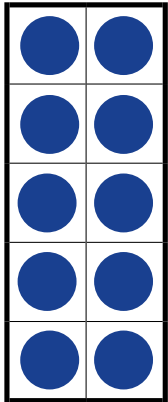
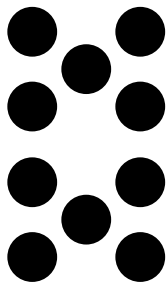

# Ma boîte à outils en mathématiques

Mon nom : \_\_\_\_\_

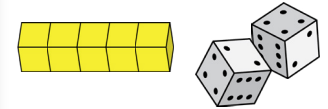
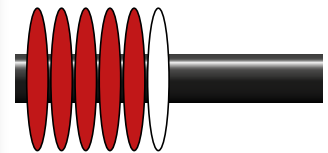
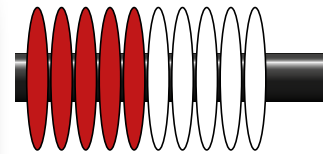

Étiquette 3

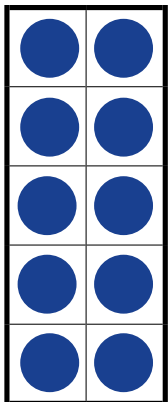
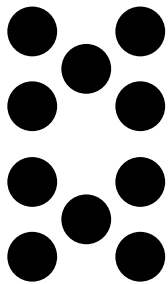

# Ma boîte à outils en mathématiques

Mon nom : \_\_\_\_\_

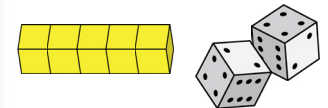
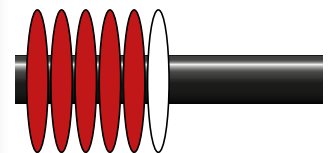
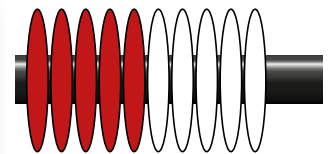

# Arrangement rectangulaire de points

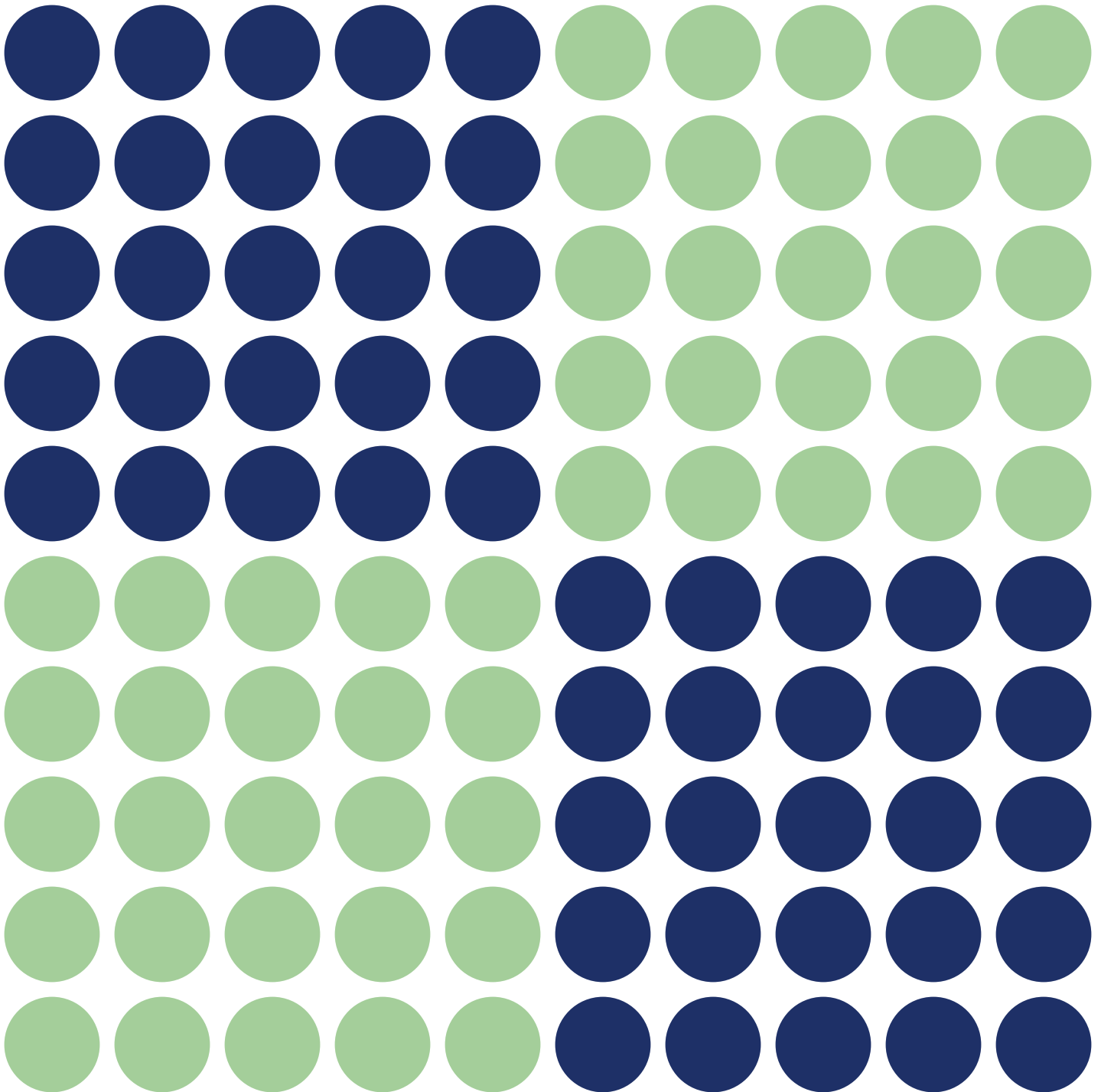

# Balance

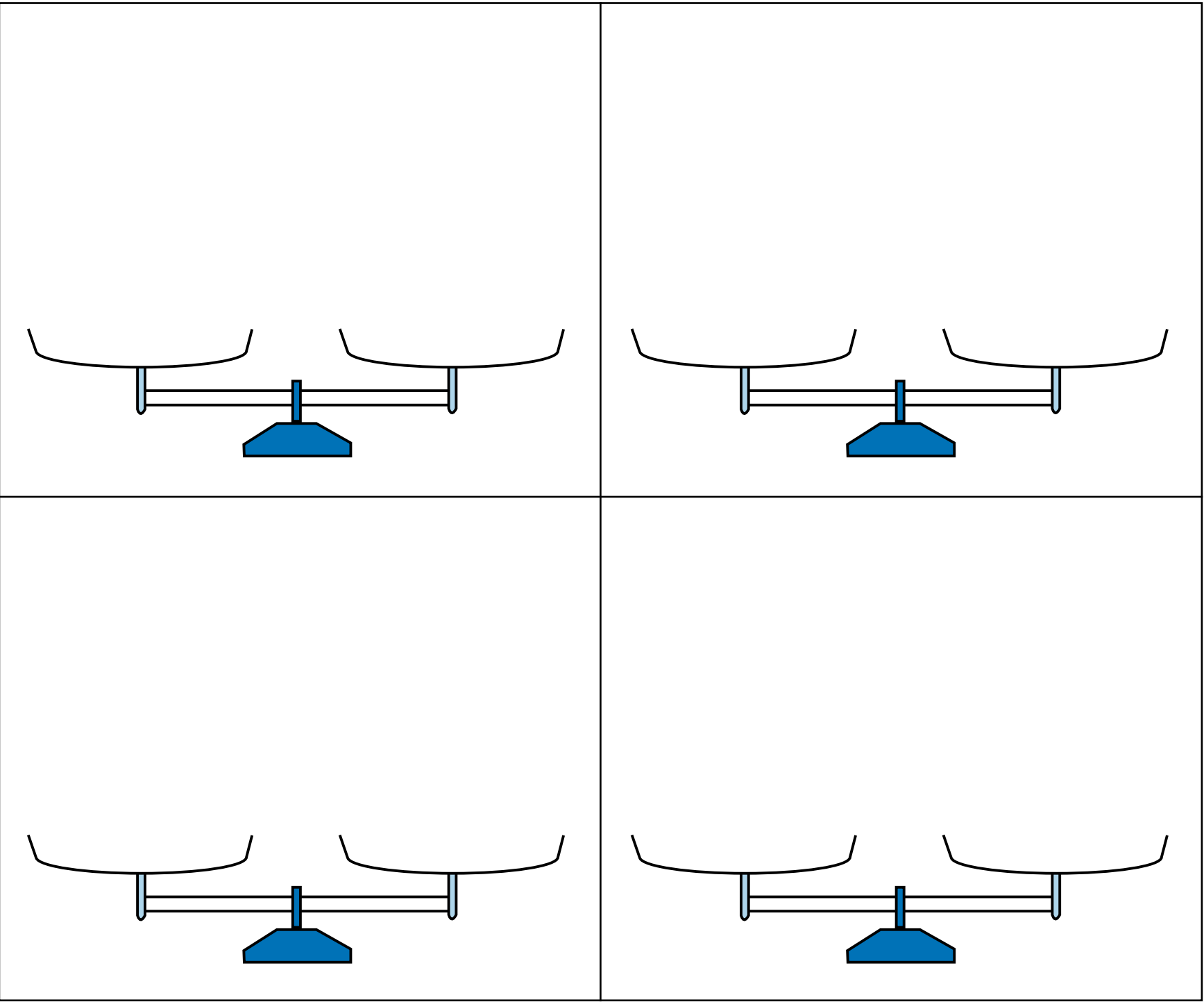



# Balance

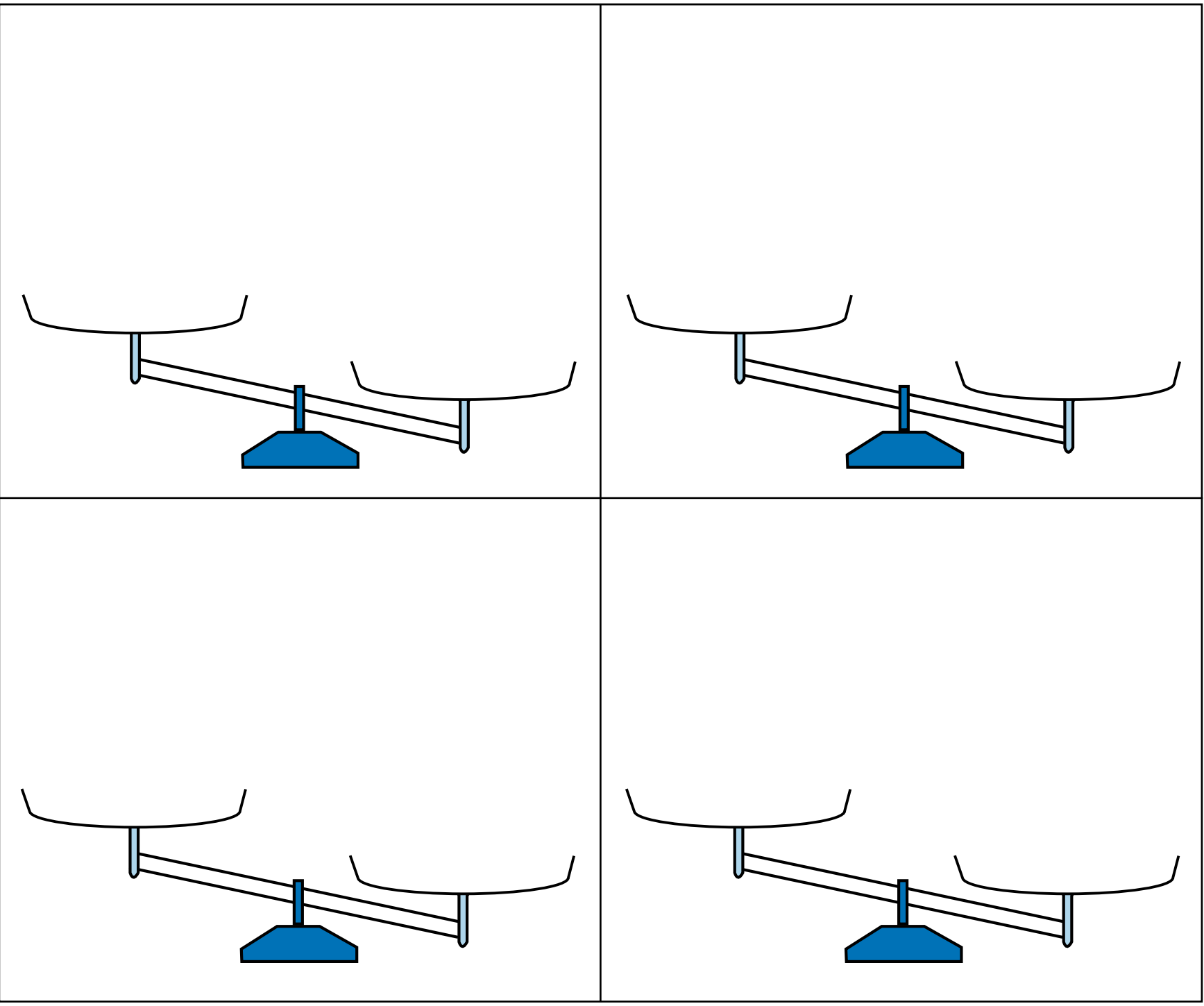

# Balance

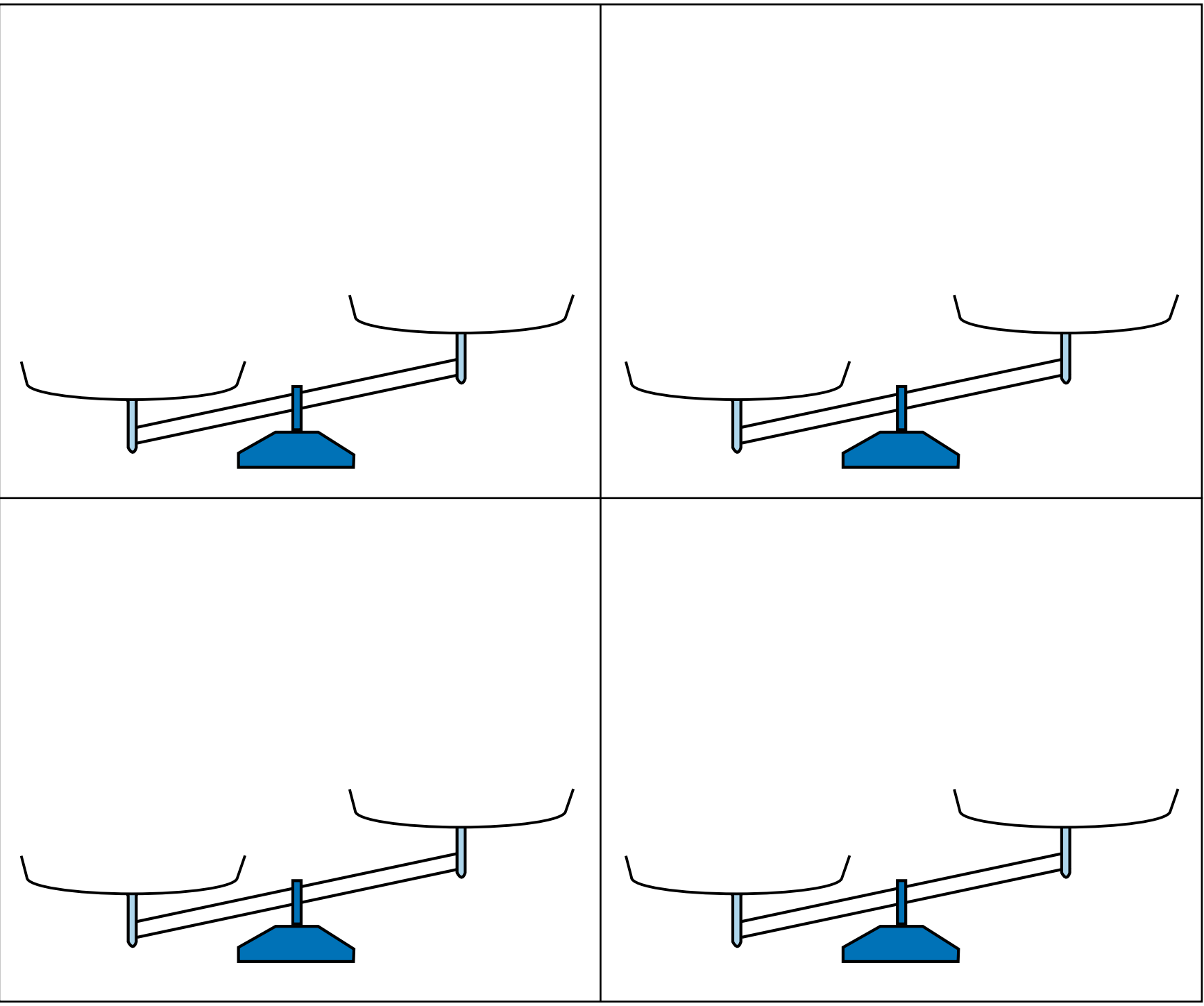

Bande numérique de 1 à 20

1	2	3	4	5	6	7	8	9	10	11	12	13	14	15	16	17	18	19	20
---	---	---	---	---	---	---	---	---	----	----	----	----	----	----	----	----	----	----	----

Bande numérique vide

--	--	--	--	--	--	--	--	--	--	--	--	--	--	--	--	--	--	--	--

Bande numérique de 1 à 20

1	2	3	4	5	6	7	8	9	10	11	12	13	14	15	16	17	18	19	20
---	---	---	---	---	---	---	---	---	----	----	----	----	----	----	----	----	----	----	----

Bande numérique vide

--	--	--	--	--	--	--	--	--	--	--	--	--	--	--	--	--	--	--	--

Bande numérique de 1 à 20

1	2	3	4	5	6	7	8	9	10	11	12	13	14	15	16	17	18	19	20
---	---	---	---	---	---	---	---	---	----	----	----	----	----	----	----	----	----	----	----

Bande numérique vide

--	--	--	--	--	--	--	--	--	--	--	--	--	--	--	--	--	--	--	--



# Blocs de base dix - représentation imagée

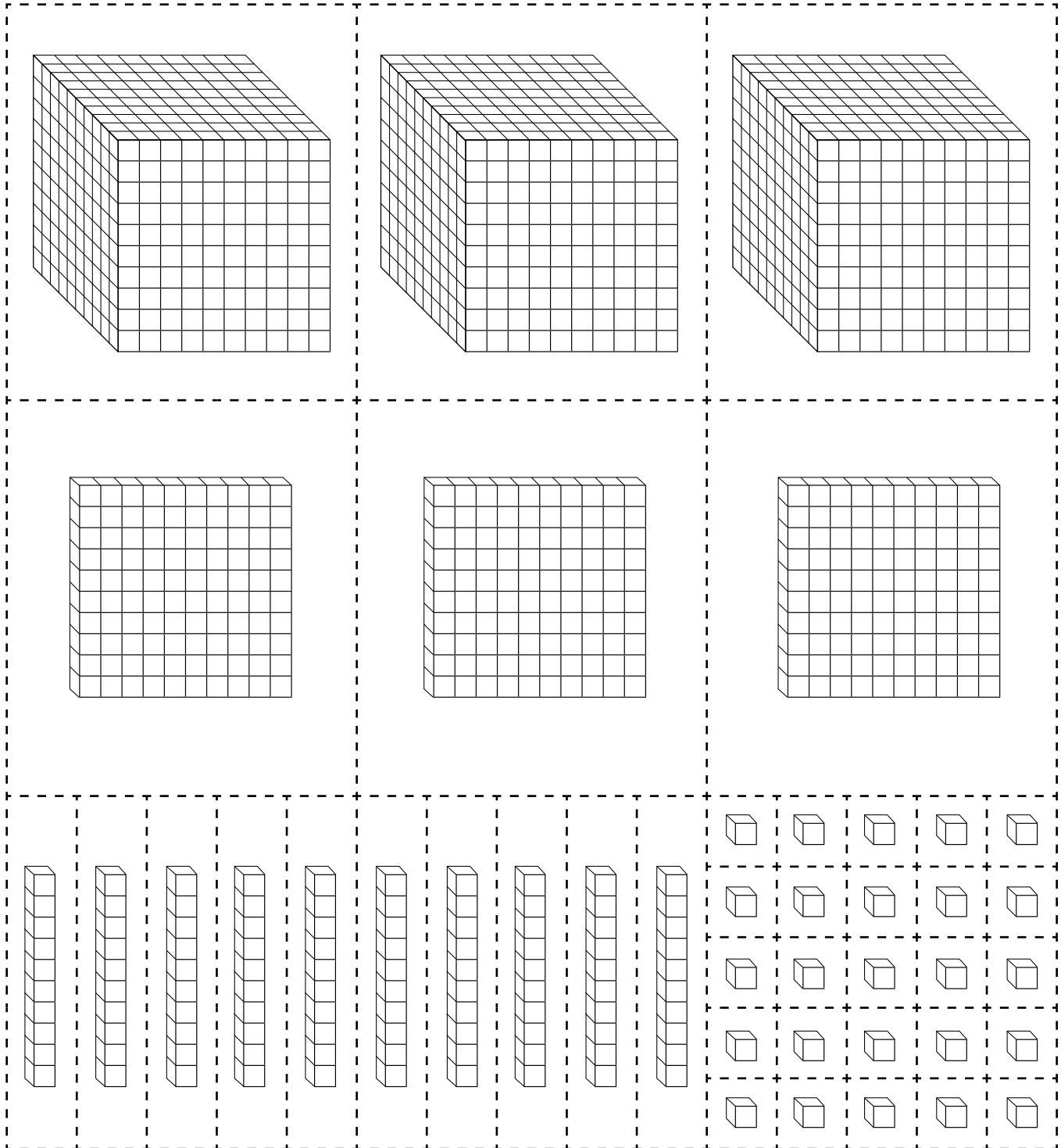

# Cartes à 5 points - Petit format

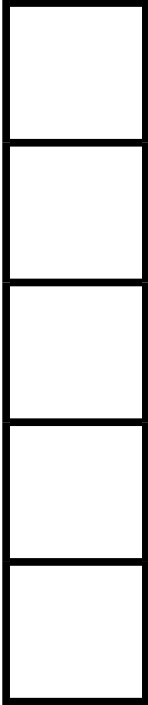
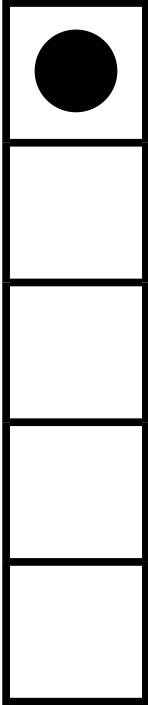
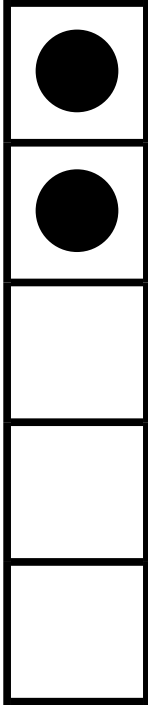
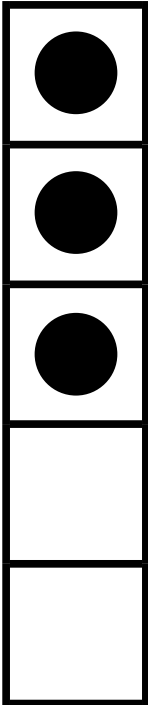
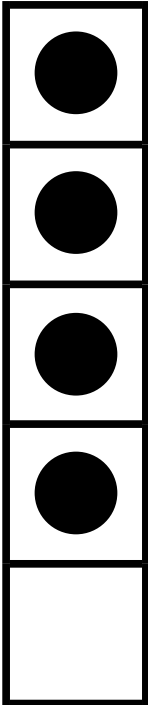
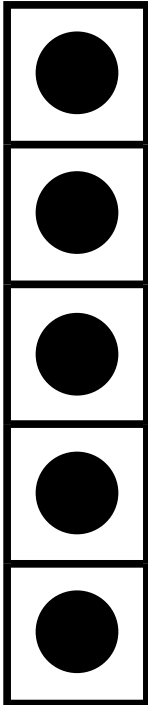



# Cartes à 5 points - Grand format

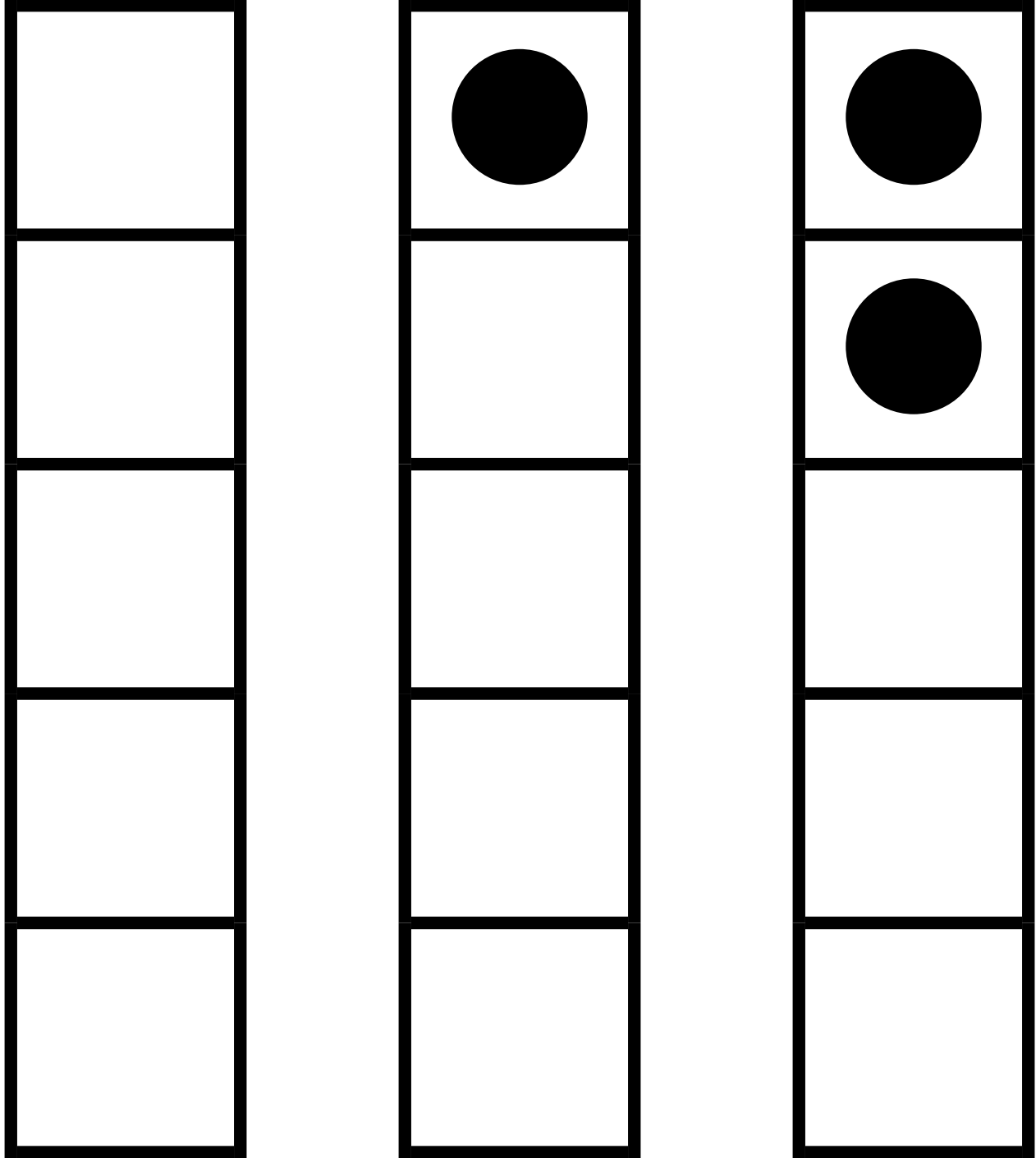

# Cartes à 5 points - Grand format (suite)

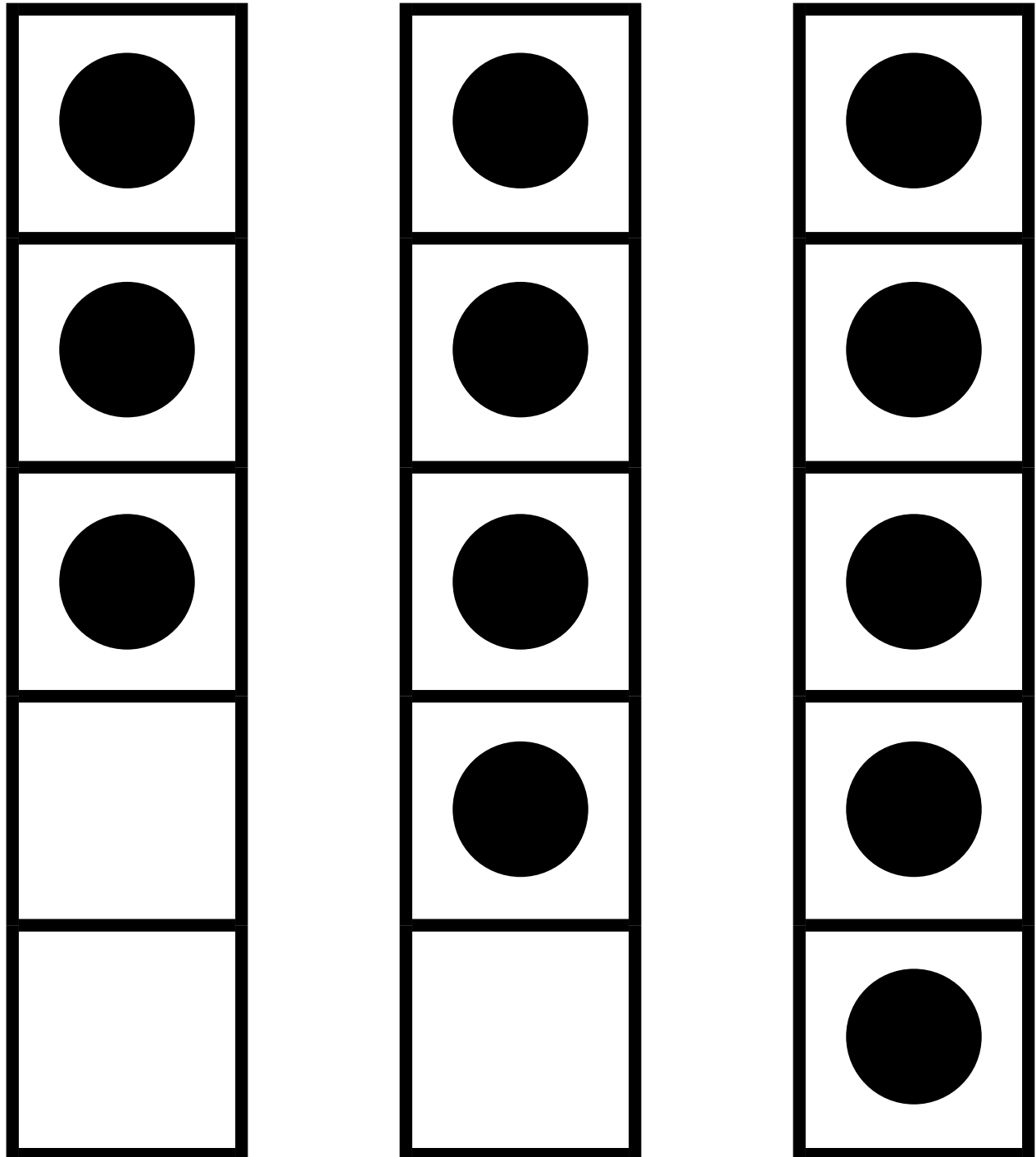

# Cartes à 10 points - représentation imagée Simple - Petit format

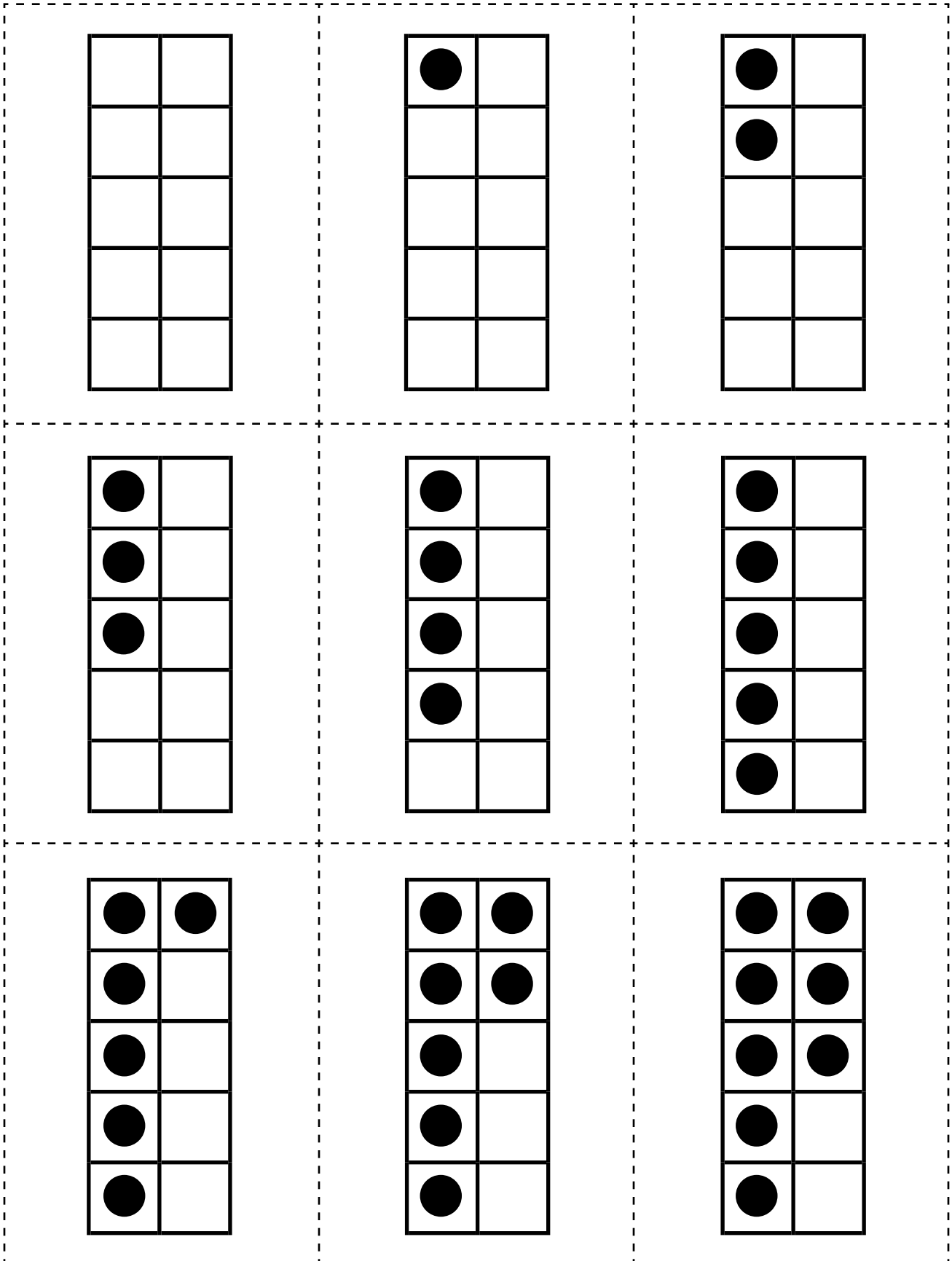

# Cartes à 10 points – représentation imagée Simple - Petit format (suite)

<table border="1"><tr><td>●</td><td>●</td></tr><tr><td>●</td><td>●</td></tr><tr><td>●</td><td>●</td></tr><tr><td>●</td><td>●</td></tr><tr><td>●</td><td></td></tr></table>	●	●	●	●	●	●	●	●	●		<table border="1"><tr><td>●</td><td>●</td></tr><tr><td>●</td><td>●</td></tr><tr><td>●</td><td>●</td></tr><tr><td>●</td><td>●</td></tr><tr><td>●</td><td>●</td></tr></table>	●	●	●	●	●	●	●	●	●	●	<table border="1"><tr><td>●</td><td>●</td></tr><tr><td>●</td><td>●</td></tr><tr><td>●</td><td>●</td></tr><tr><td>●</td><td>●</td></tr><tr><td>●</td><td>●</td></tr></table>	●	●	●	●	●	●	●	●	●	●
●	●																															
●	●																															
●	●																															
●	●																															
●																																
●	●																															
●	●																															
●	●																															
●	●																															
●	●																															
●	●																															
●	●																															
●	●																															
●	●																															
●	●																															
<table border="1"><tr><td>●</td><td>●</td></tr><tr><td>●</td><td>●</td></tr><tr><td>●</td><td>●</td></tr><tr><td>●</td><td>●</td></tr><tr><td>●</td><td>●</td></tr></table>	●	●	●	●	●	●	●	●	●	●	<table border="1"><tr><td>●</td><td>●</td></tr><tr><td>●</td><td>●</td></tr><tr><td>●</td><td>●</td></tr><tr><td>●</td><td>●</td></tr><tr><td>●</td><td>●</td></tr></table>	●	●	●	●	●	●	●	●	●	●	<table border="1"><tr><td>●</td><td>●</td></tr><tr><td>●</td><td>●</td></tr><tr><td>●</td><td>●</td></tr><tr><td>●</td><td>●</td></tr><tr><td>●</td><td>●</td></tr></table>	●	●	●	●	●	●	●	●	●	●
●	●																															
●	●																															
●	●																															
●	●																															
●	●																															
●	●																															
●	●																															
●	●																															
●	●																															
●	●																															
●	●																															
●	●																															
●	●																															
●	●																															
●	●																															
<table border="1"><tr><td>●</td><td>●</td></tr><tr><td>●</td><td>●</td></tr><tr><td>●</td><td>●</td></tr><tr><td>●</td><td>●</td></tr><tr><td>●</td><td>●</td></tr></table>	●	●	●	●	●	●	●	●	●	●	<table border="1"><tr><td>●</td><td>●</td></tr><tr><td>●</td><td>●</td></tr><tr><td>●</td><td>●</td></tr><tr><td>●</td><td>●</td></tr><tr><td>●</td><td>●</td></tr></table>	●	●	●	●	●	●	●	●	●	●	<table border="1"><tr><td>●</td><td>●</td></tr><tr><td>●</td><td>●</td></tr><tr><td>●</td><td>●</td></tr><tr><td>●</td><td>●</td></tr><tr><td>●</td><td>●</td></tr></table>	●	●	●	●	●	●	●	●	●	●
●	●																															
●	●																															
●	●																															
●	●																															
●	●																															
●	●																															
●	●																															
●	●																															
●	●																															
●	●																															
●	●																															
●	●																															
●	●																															
●	●																															
●	●																															



# Cartes à 10 points - représentation imagée Simple - Grand format

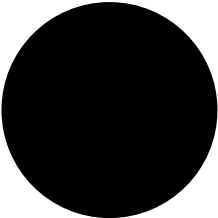





# Cartes à 10 points - représentation imagée

## Simple - Grand format (suite)

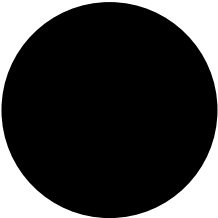
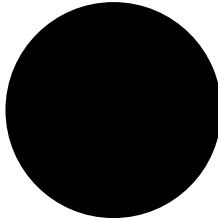

# Cartes à 10 points - représentation imagée

## Simple - Grand format (suite)

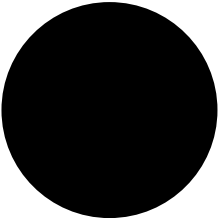
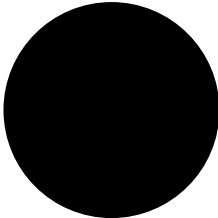
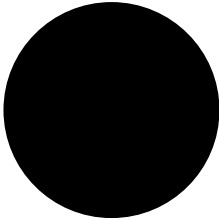

# Cartes à 10 points - représentation imagée

## Simple - Grand format (suite)

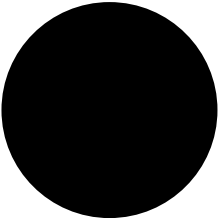
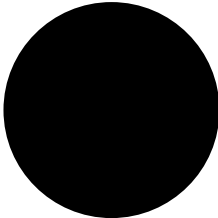
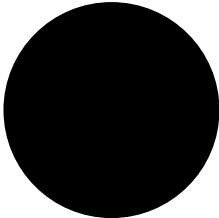
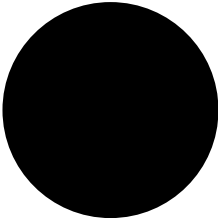

# Cartes à 10 points - représentation imagée

## Simple - Grand format (suite)

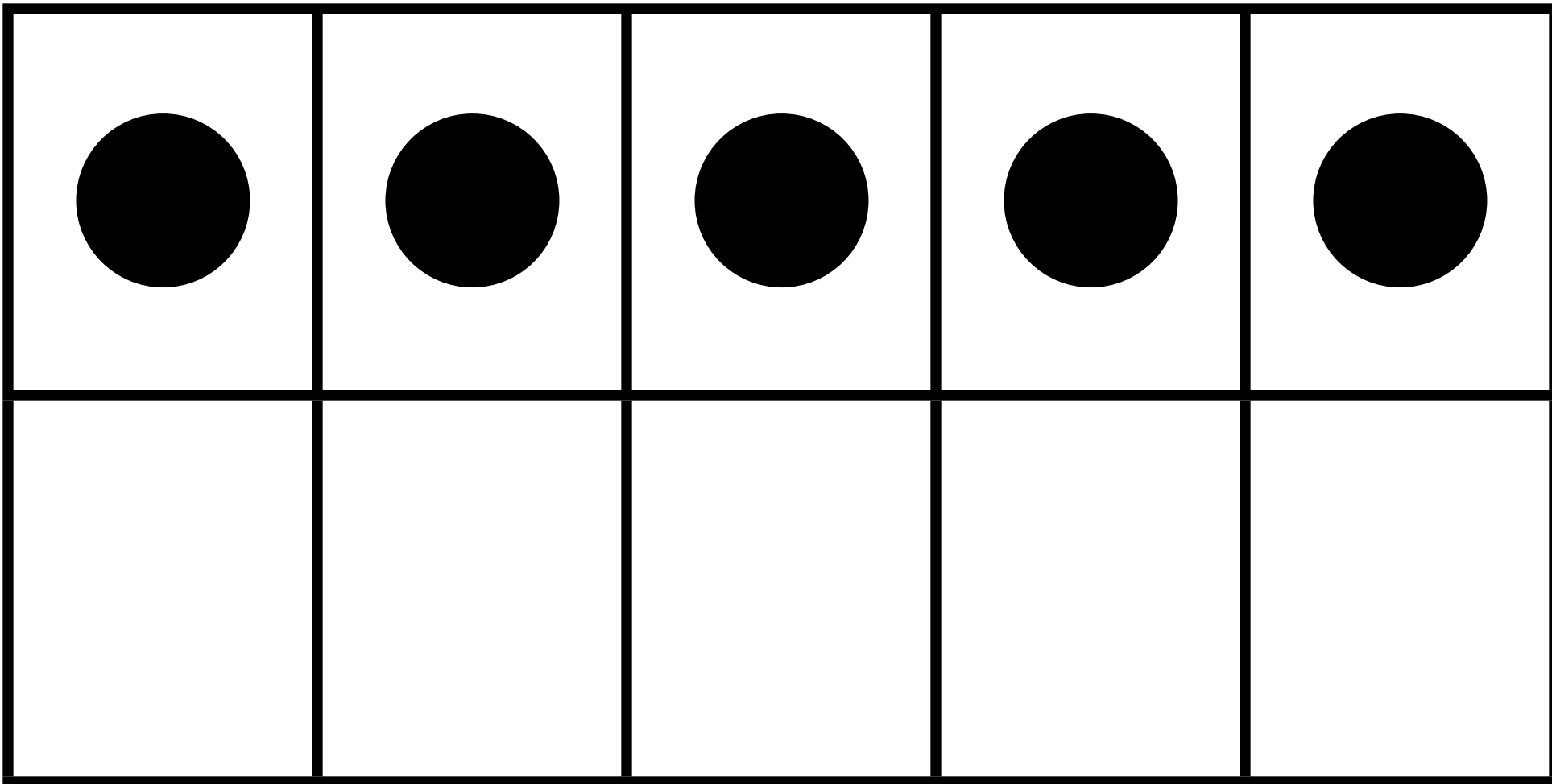

# Cartes à 10 points - représentation imagée

## Simple - Grand format (suite)

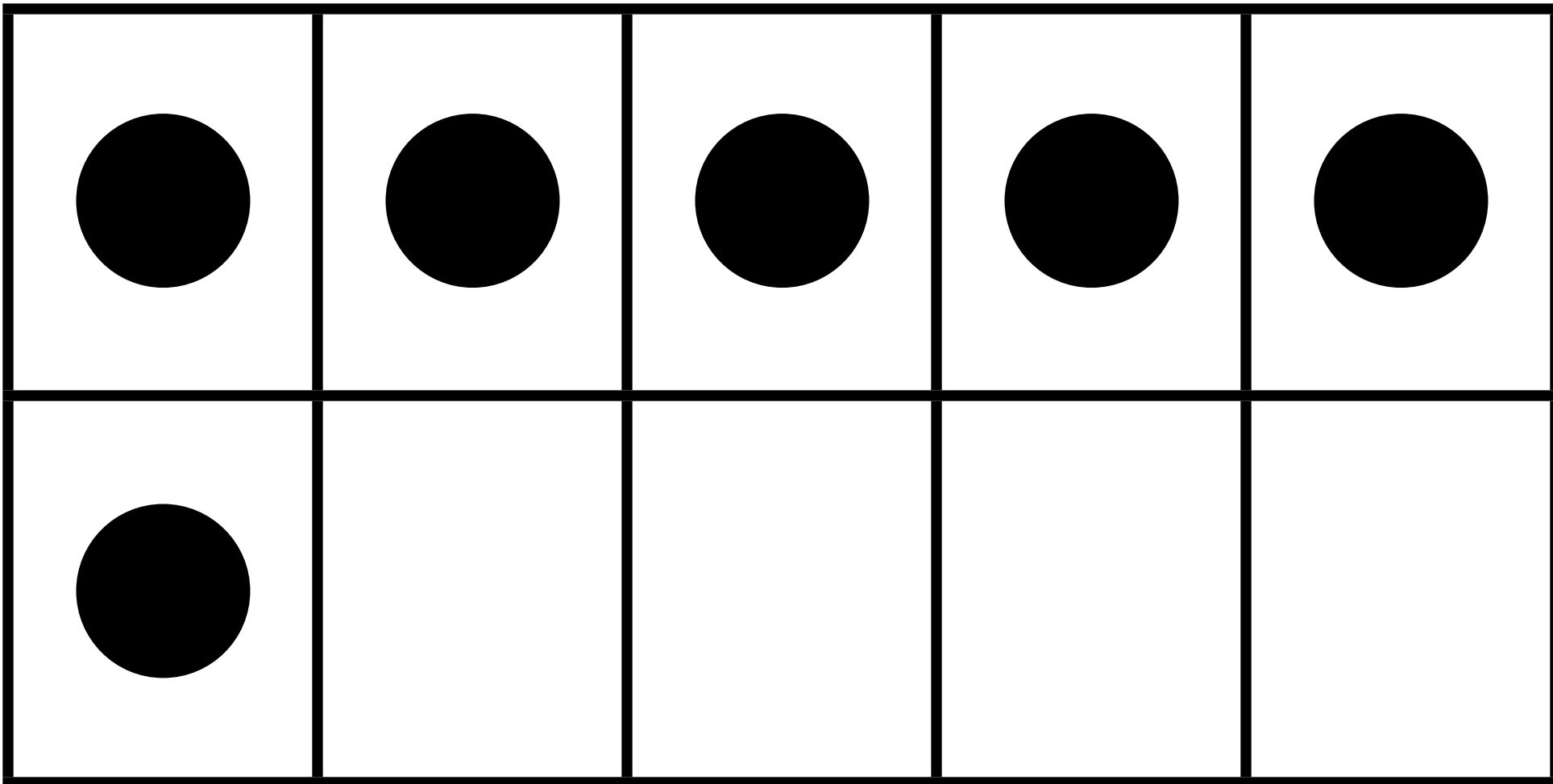

# Cartes à 10 points - représentation imagée

## Simple - Grand format (suite)

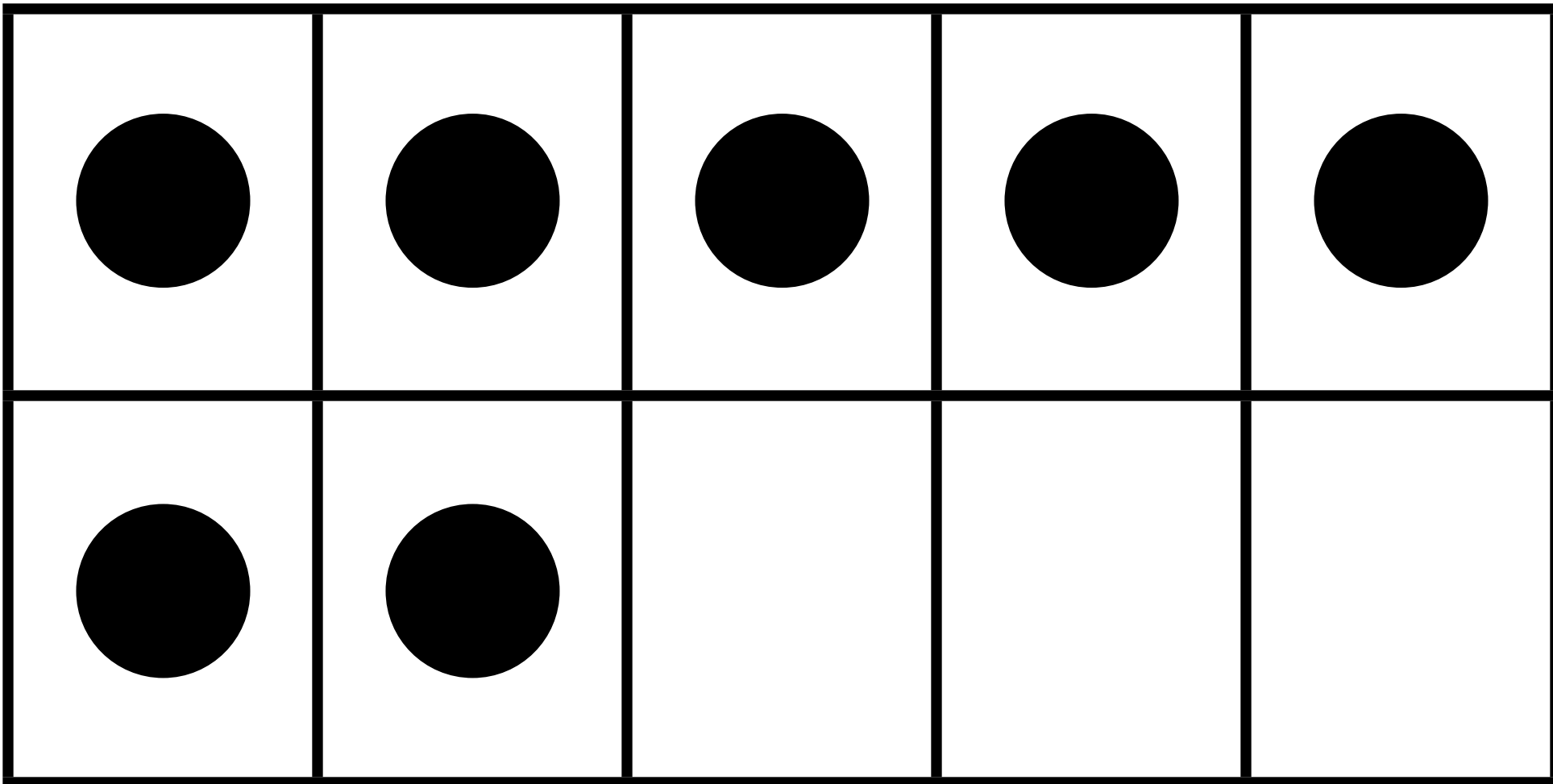



# Cartes à 10 points - représentation imagée

## Simple - Grand format (suite)

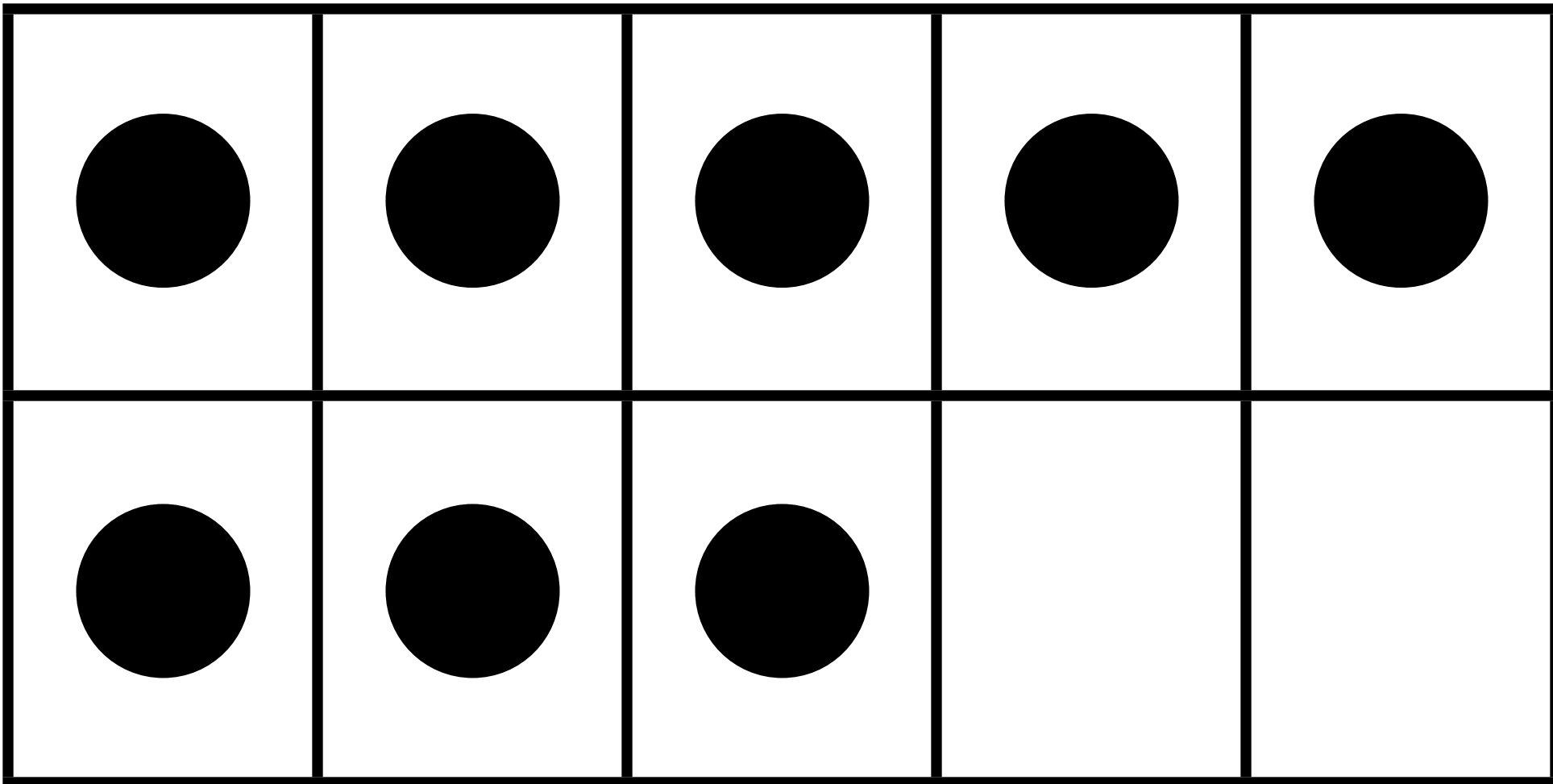

# Cartes à 10 points - représentation imagée

## Simple - Grand format (suite)

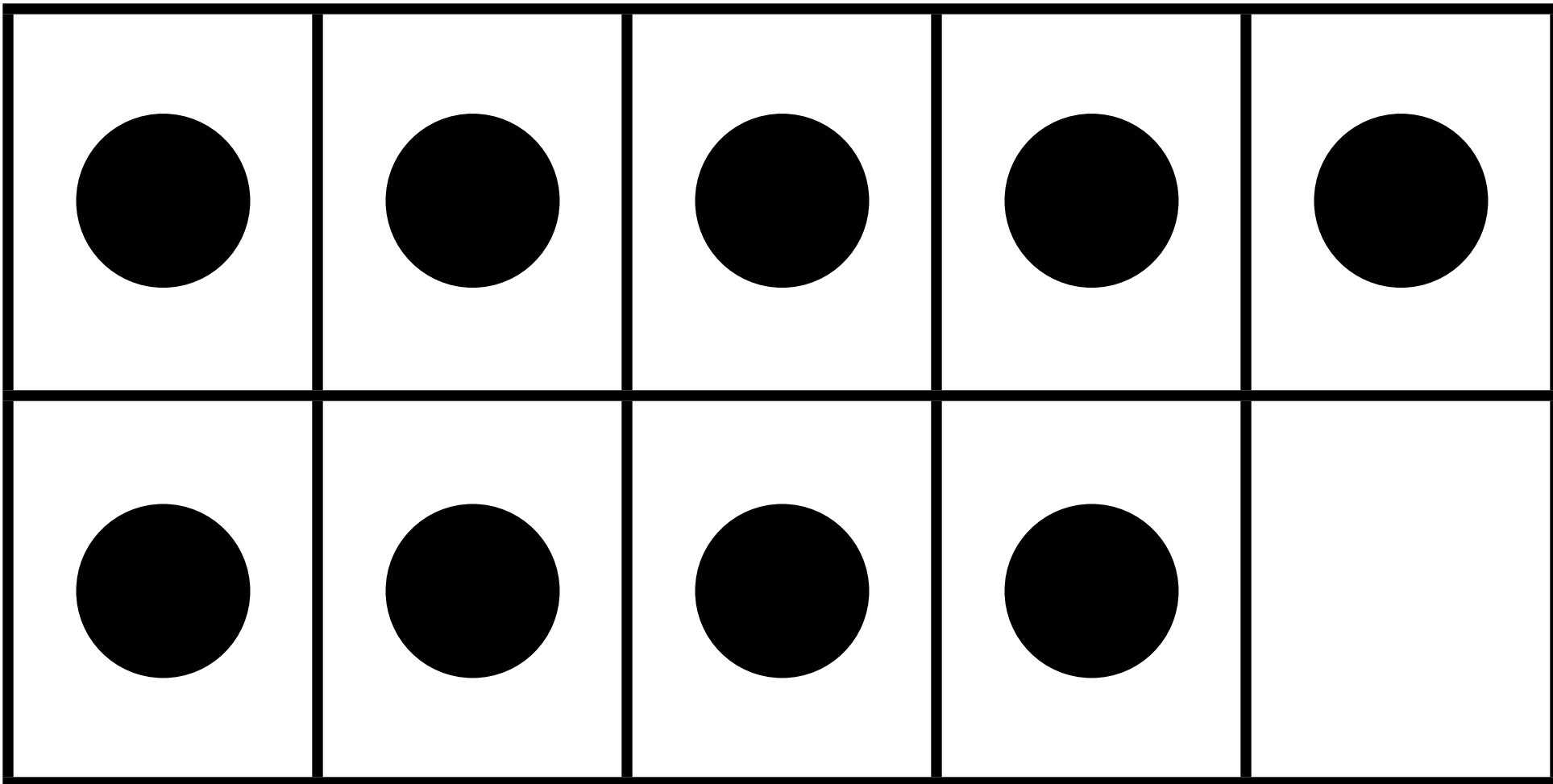

# Cartes à 10 points - représentation imagée

## Simple - Grand format (suite)

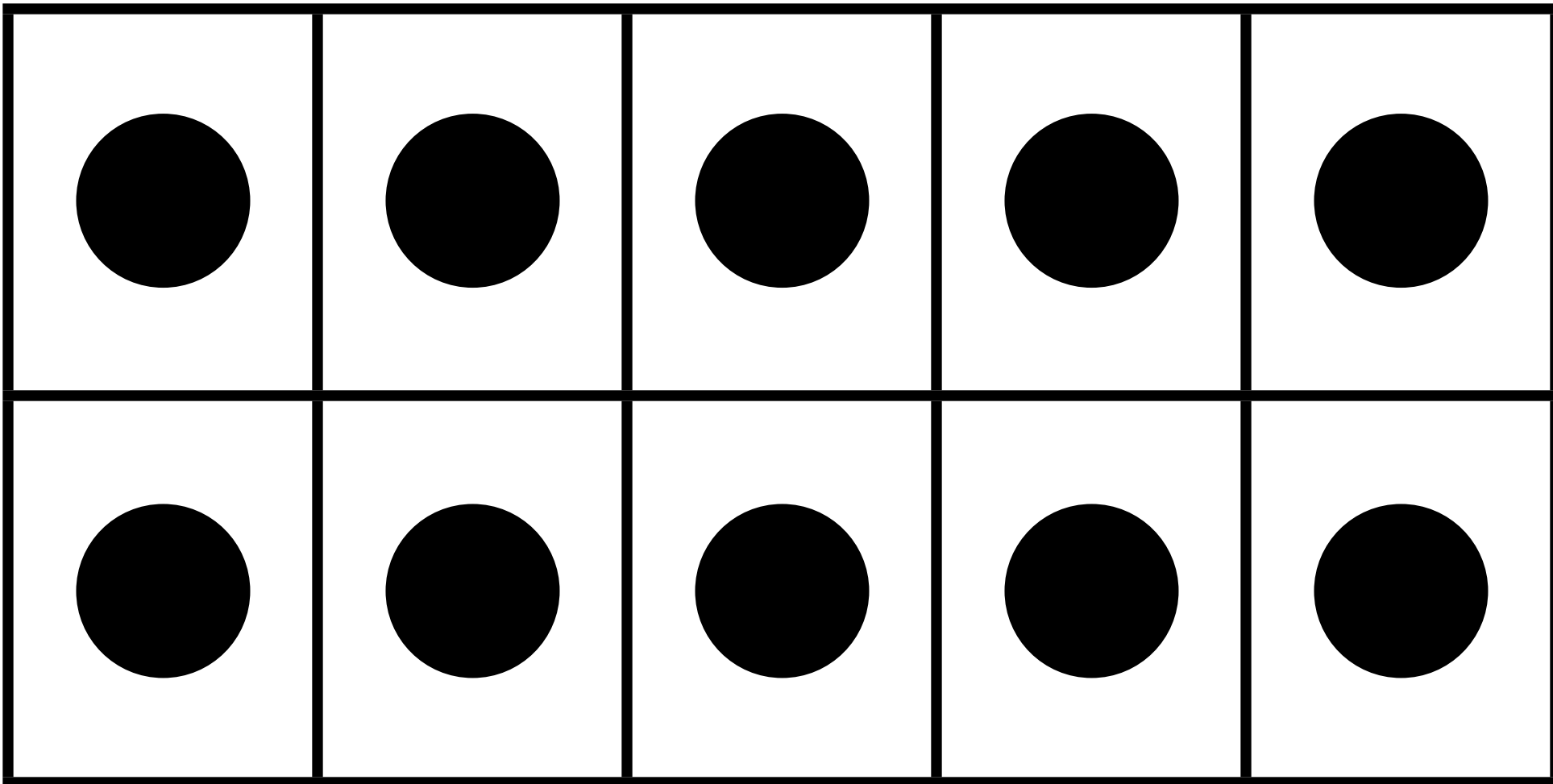

# Cartes à 10 points - représentation imagée

## Double - Petit format



# Cartes à 10 points – représentation imagée

## Double - Petit format (suite)

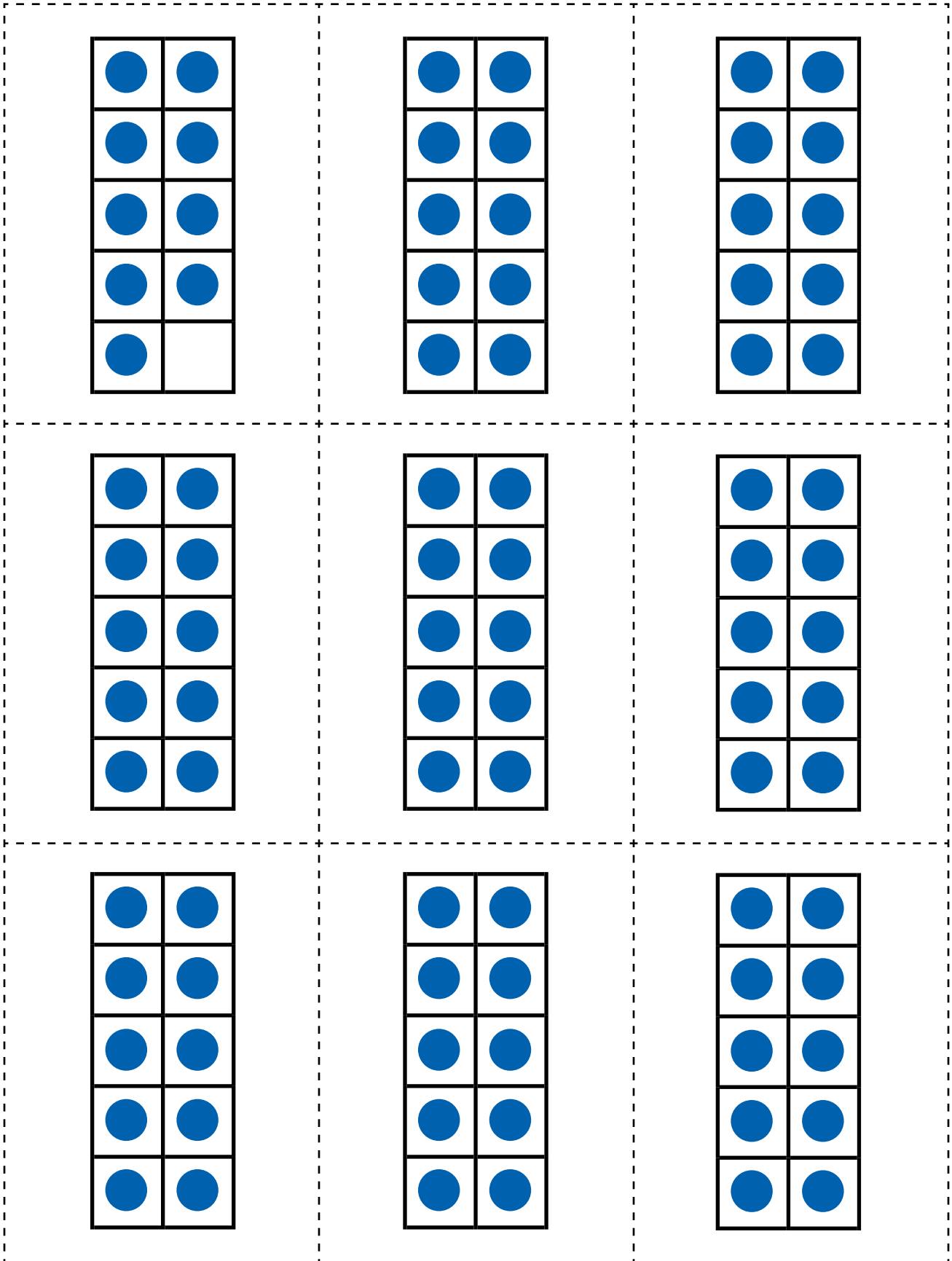

# Cartes à 10 points - représentation imagée

## Double - Grand format

				





# Cartes à 10 points - représentation imagée

## Double - Grand format (suite)

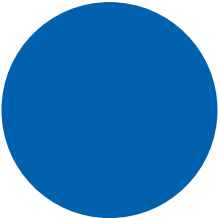

# Cartes à 10 points - représentation imagée

## Double - Grand format (suite)

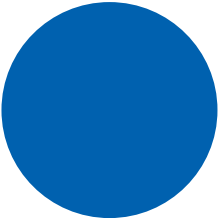
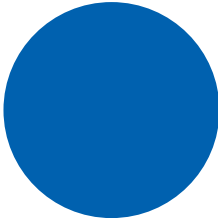
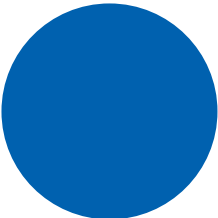

# Cartes à 10 points - représentation imagée

## Double - Grand format (suite)

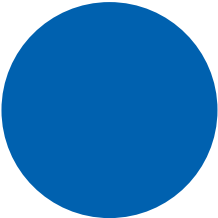
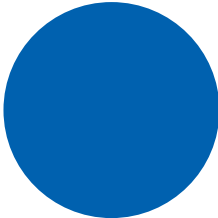
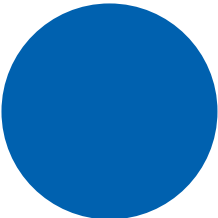
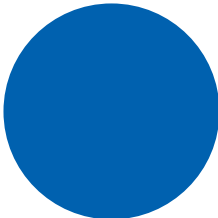

# Cartes à 10 points - représentation imagée

## Double - Grand format (suite)

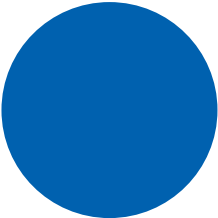
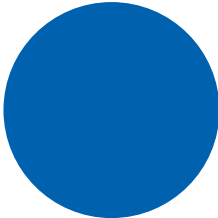
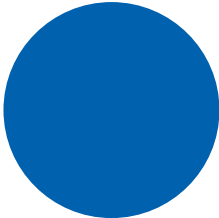
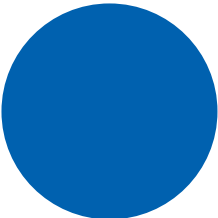
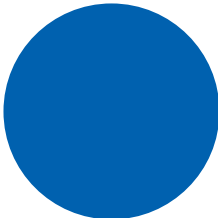

# Cartes à 10 points - représentation imagée

## Double - Grand format (suite)

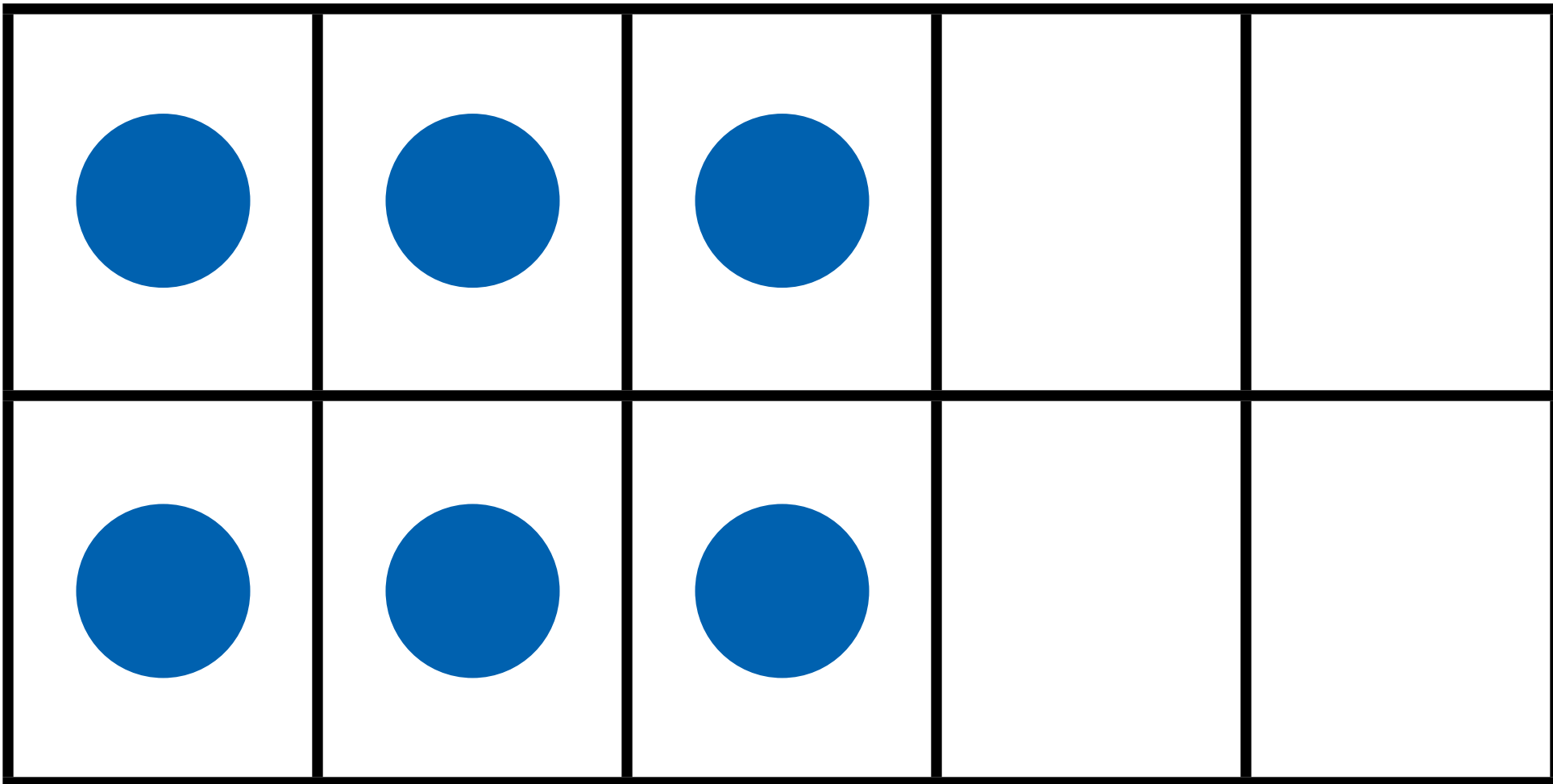

# Cartes à 10 points - représentation imagée

## Double - Grand format (suite)

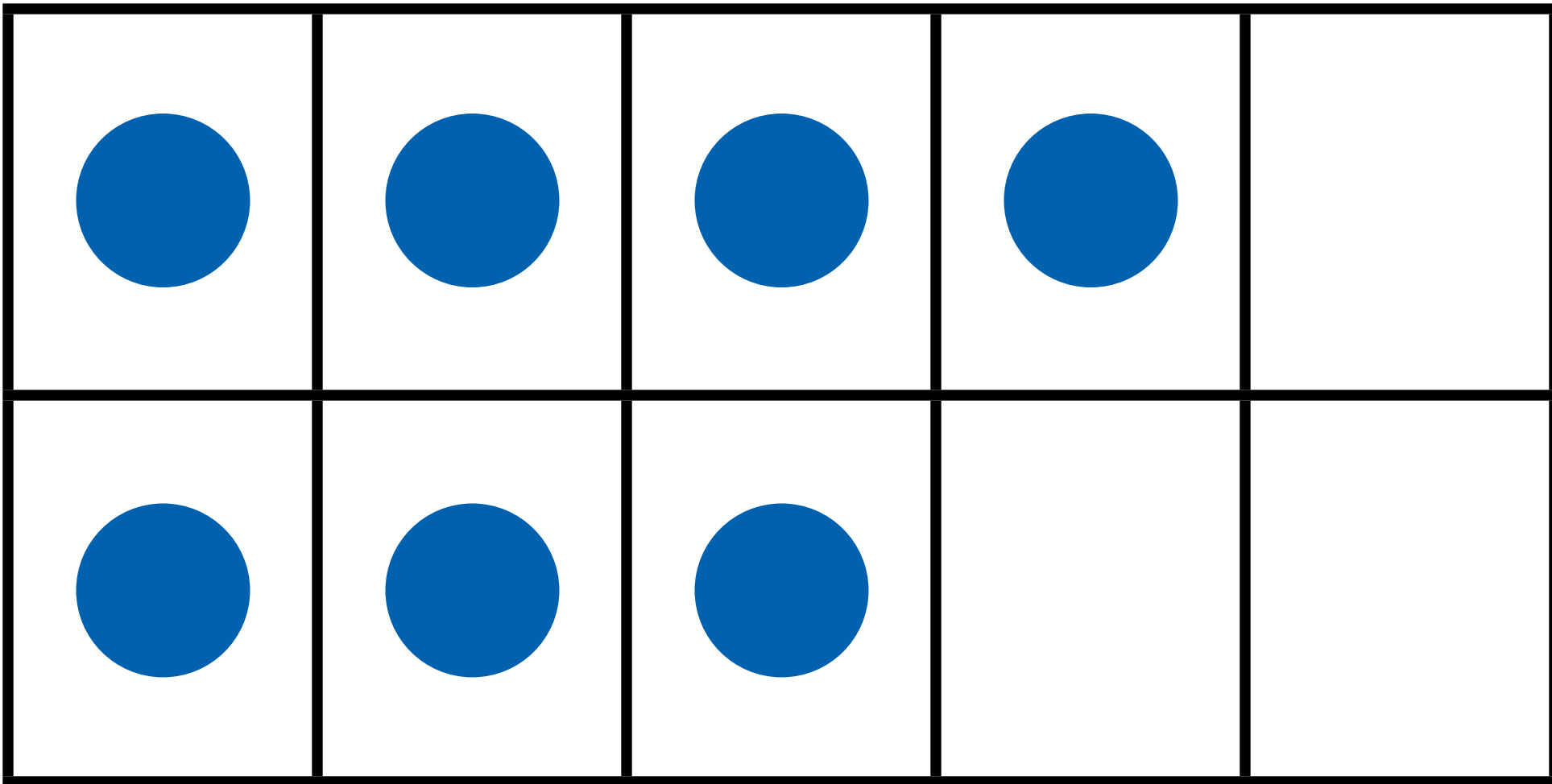



# Cartes à 10 points - représentation imagée

## Double - Grand format (suite)

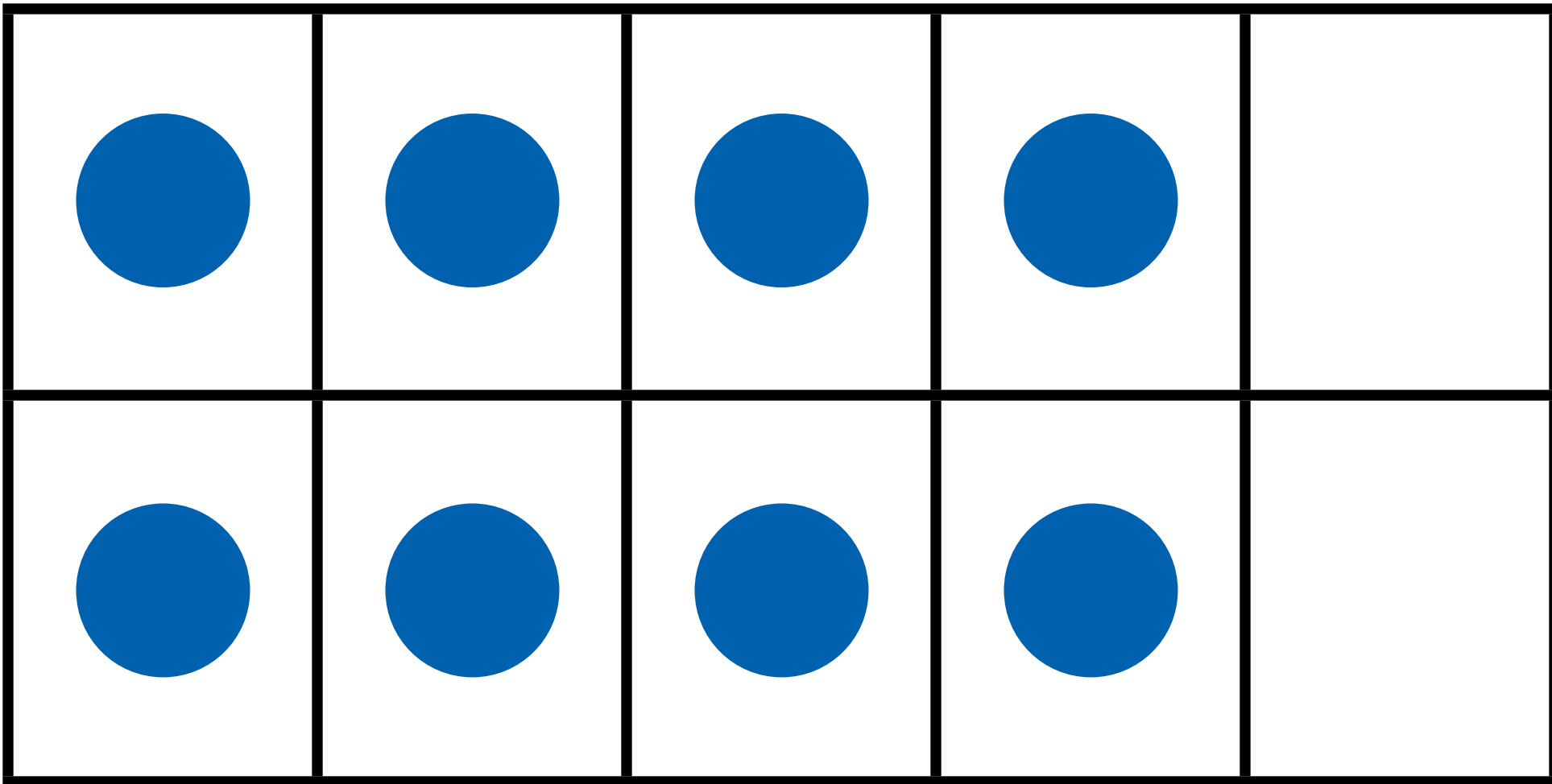

# Cartes à 10 points - représentation imagée

## Double - Grand format (suite)

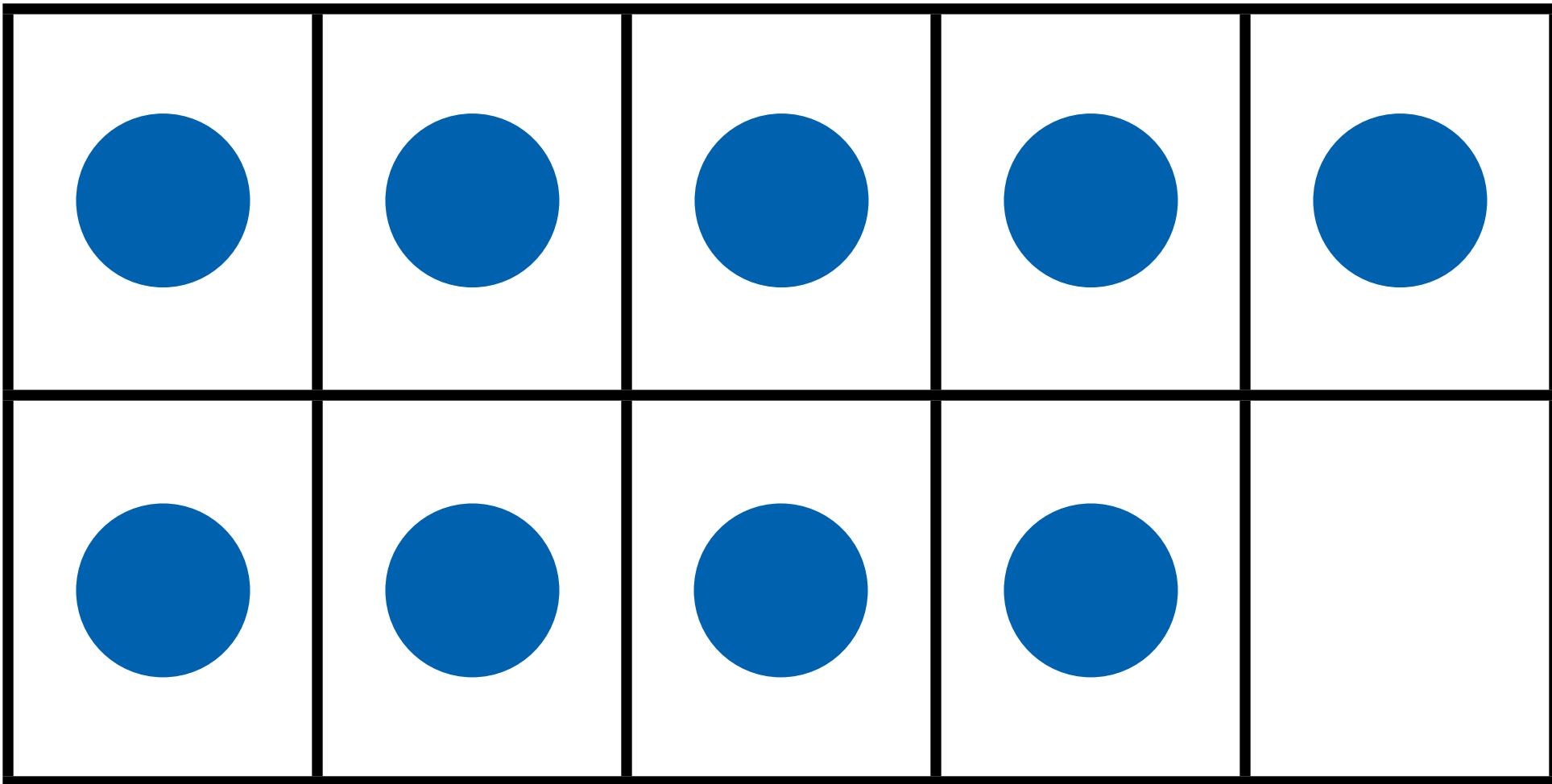

# Cartes à 10 points - représentation imagée

## Double - Grand format (suite)

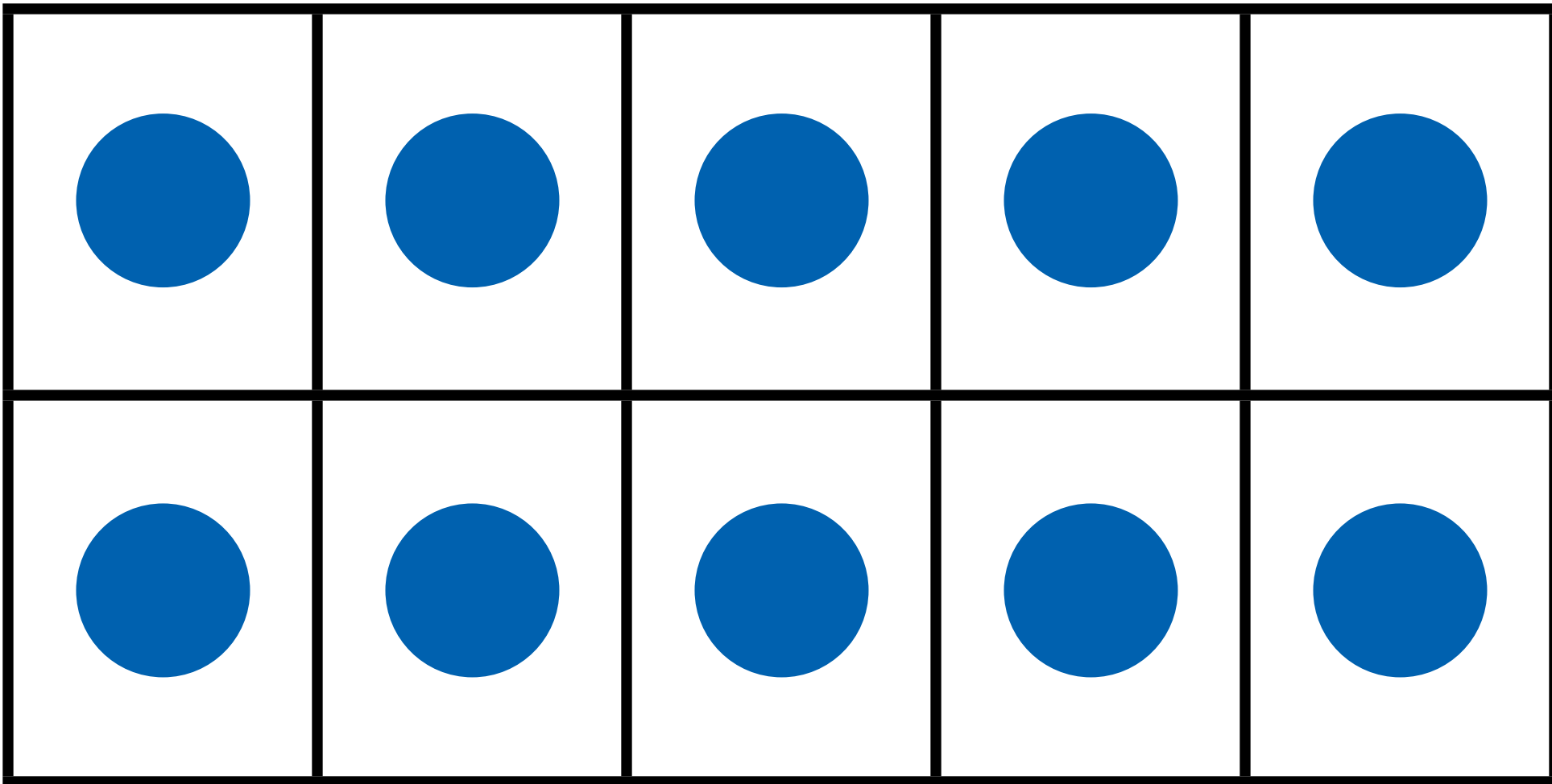

## Carte à 10 points vide (Horizontal)





# Carte à 10 points - Vide (Vertical)



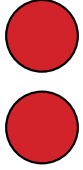
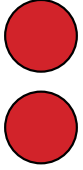
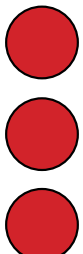

# Cartes de la partie manquante

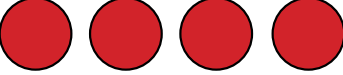
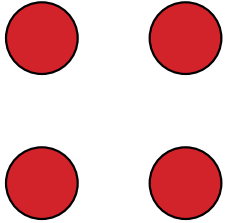
4		
4		
4		
4		







5

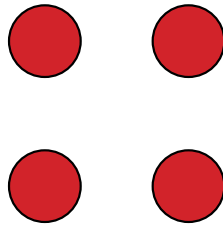

5

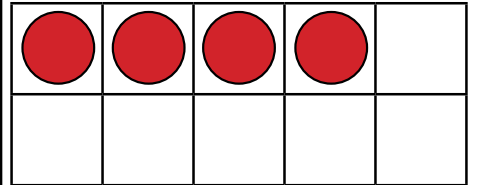

5

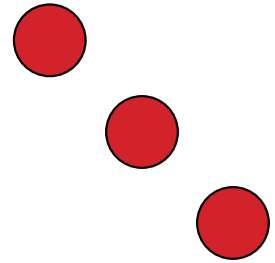
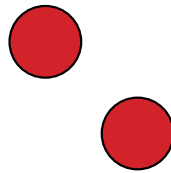

5

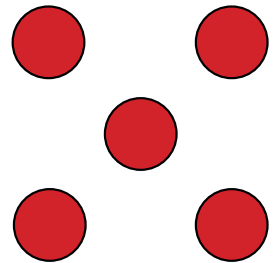

5

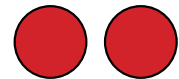
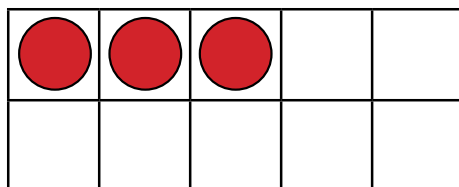



6

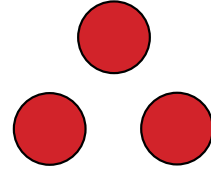
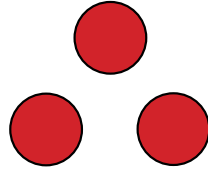

6

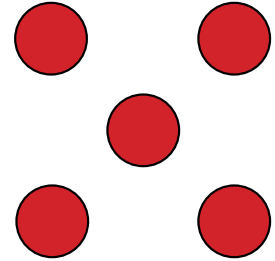

6

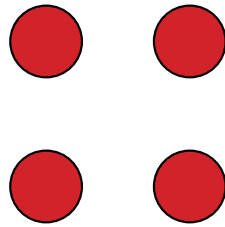

6

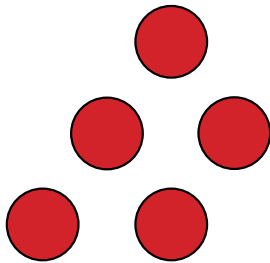

6

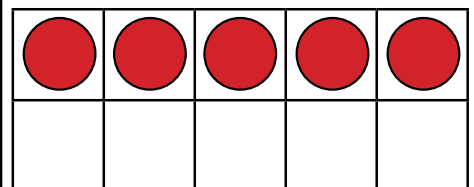



7

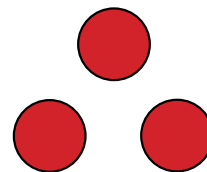
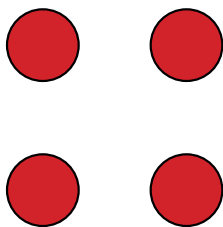

7

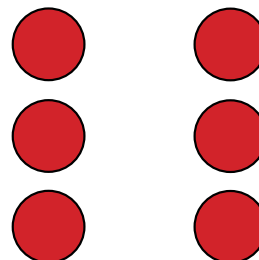

7

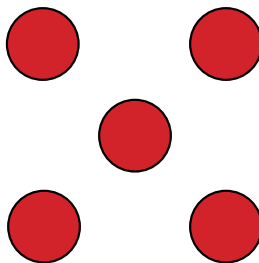

7

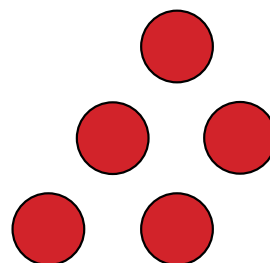
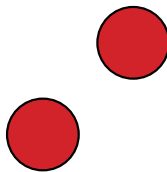

7

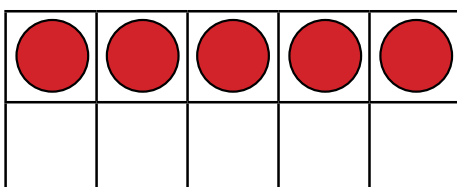

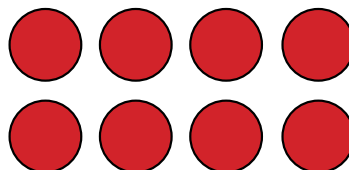
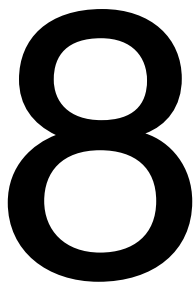
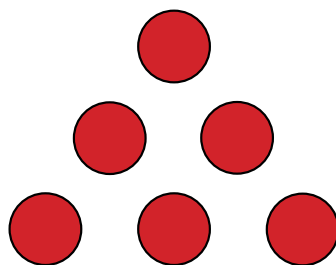
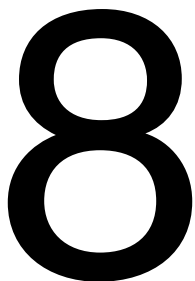
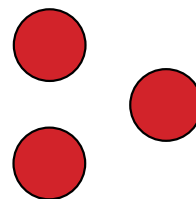
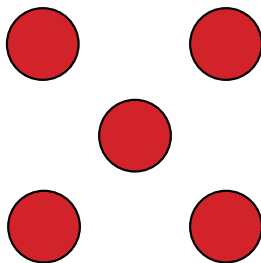
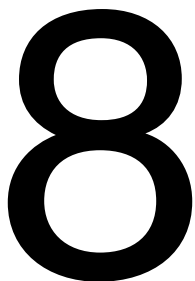
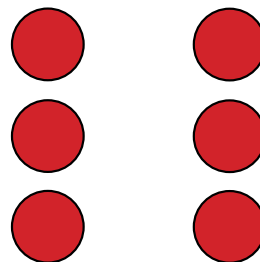
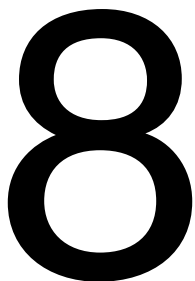
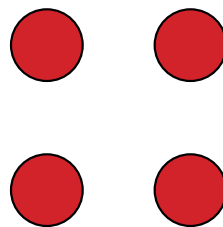
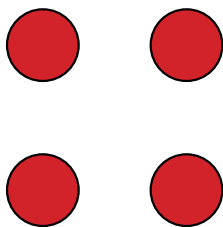
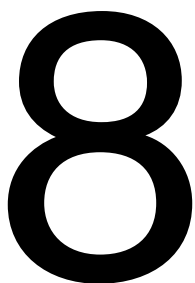



9

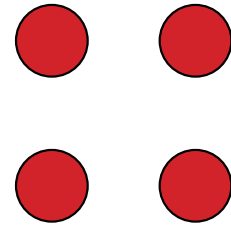
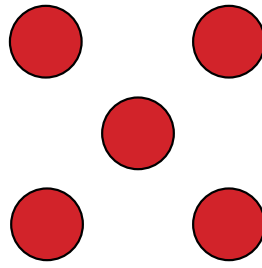

9

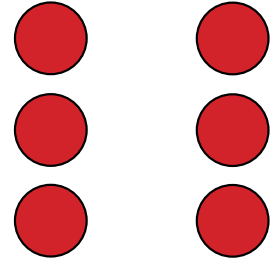
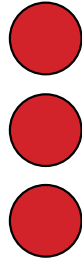

9

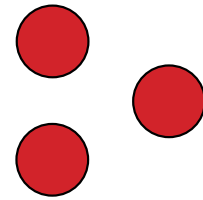
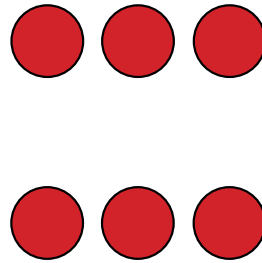

9

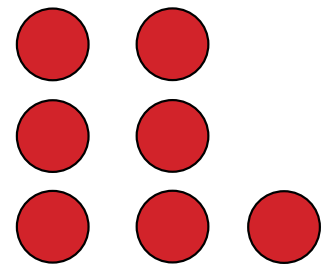
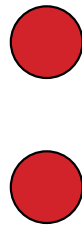

9

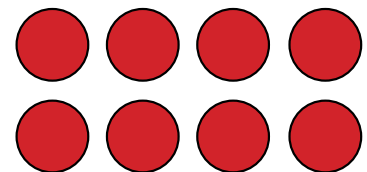



9



9



9

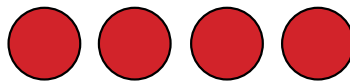

9



9







10

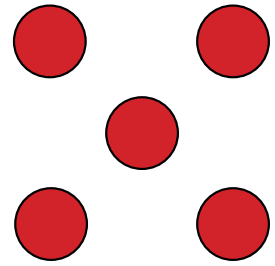
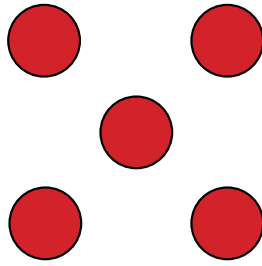

10

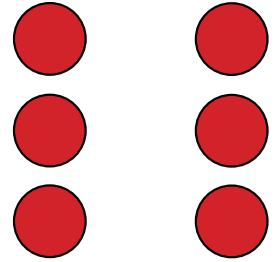
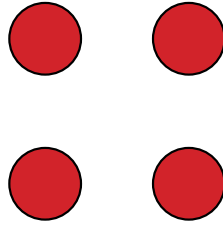

10

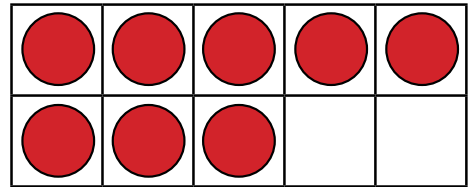

10

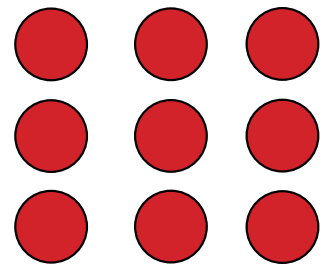

10

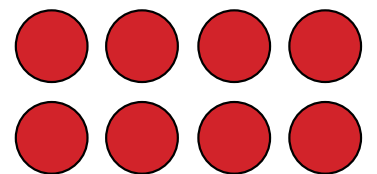





10

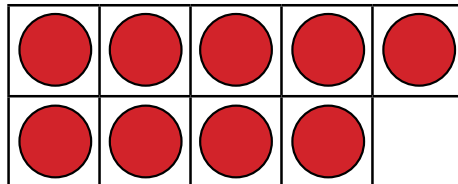

10

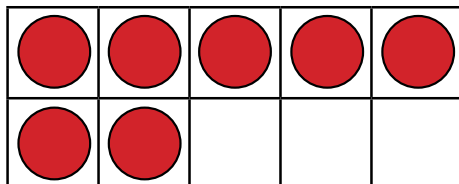

10

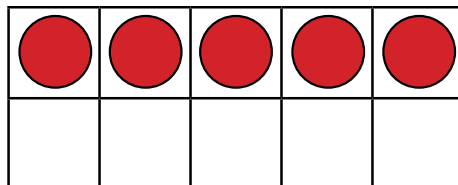
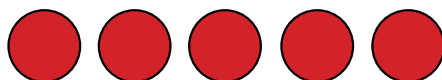

10

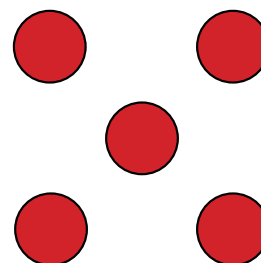
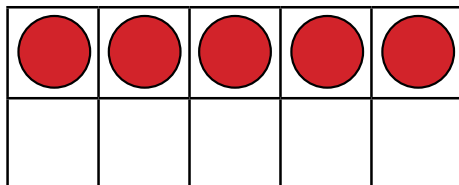

10

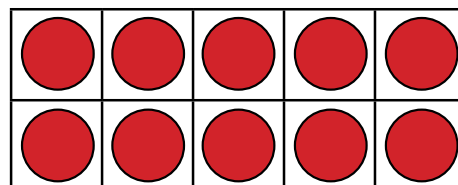



11

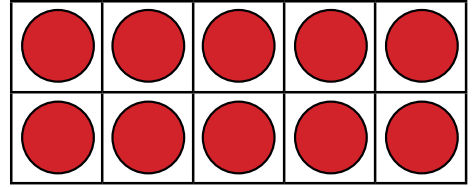

11

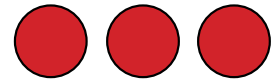
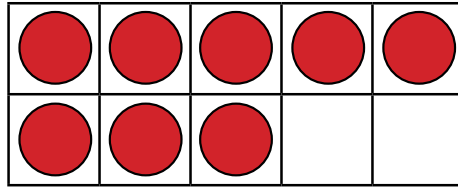

11

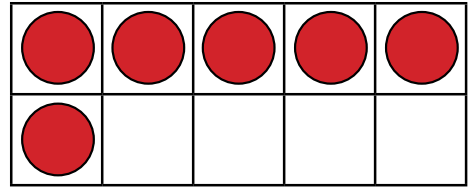
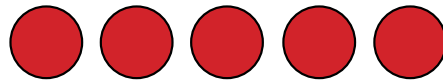

11

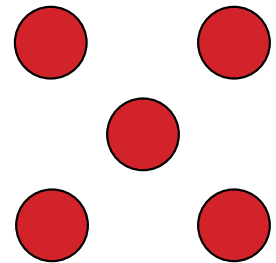
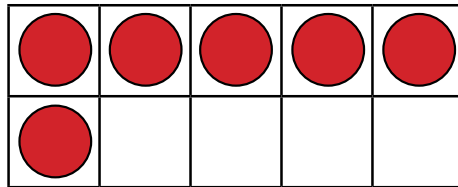

11

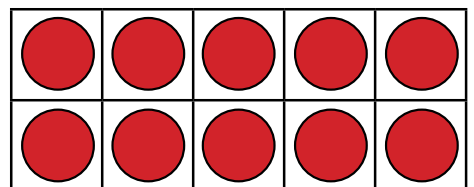
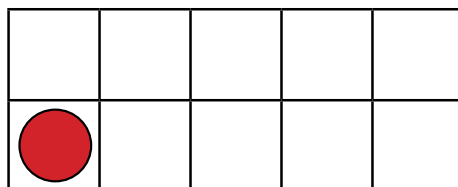



11

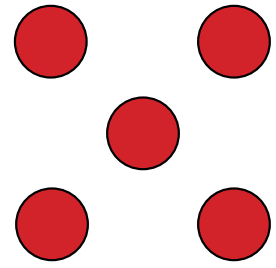
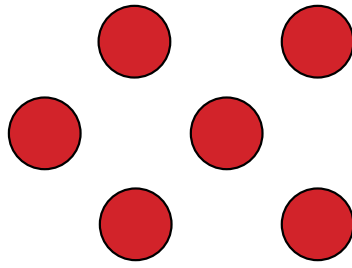

11

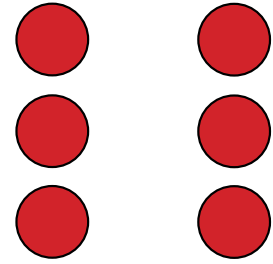
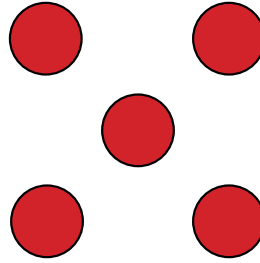

11

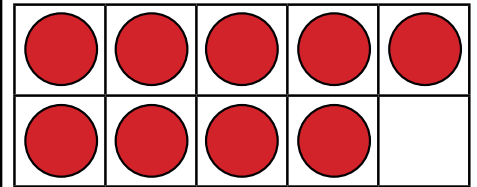

11

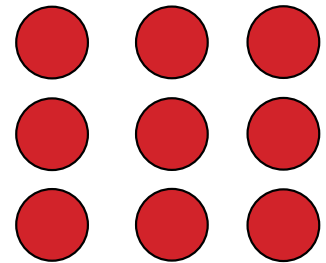
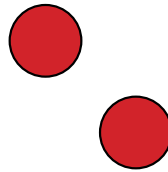

11

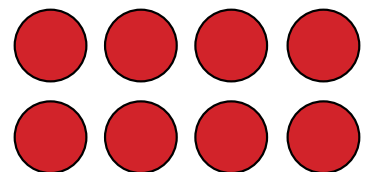
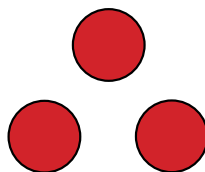



12

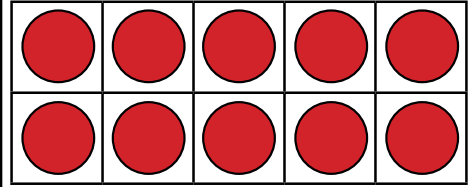
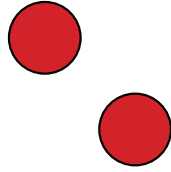

12

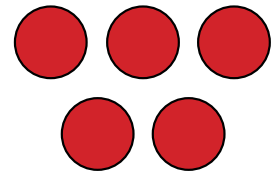
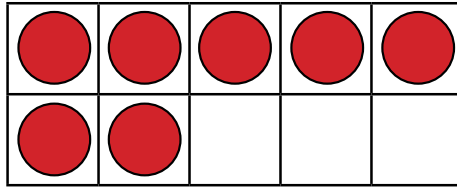

12

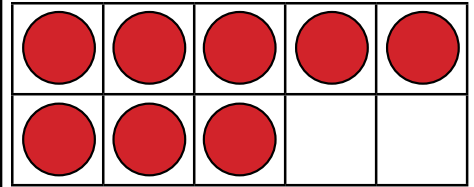
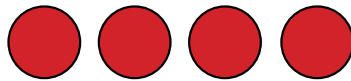

12

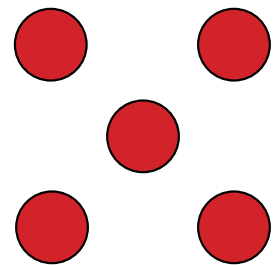
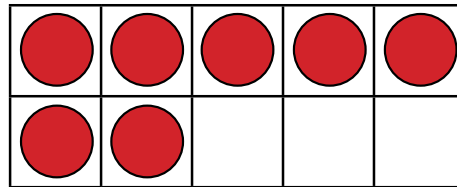

12

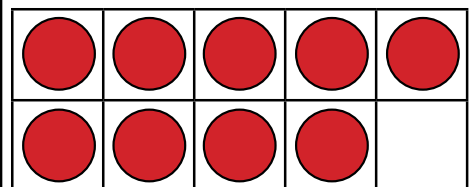
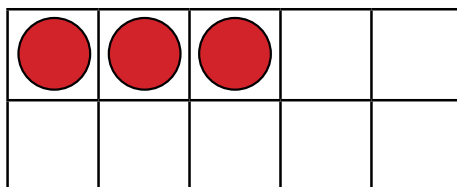



12

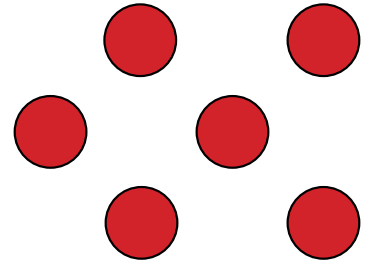
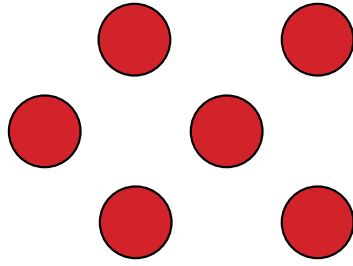

12

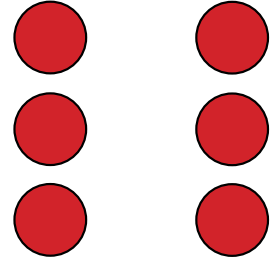
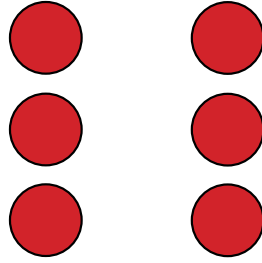

12

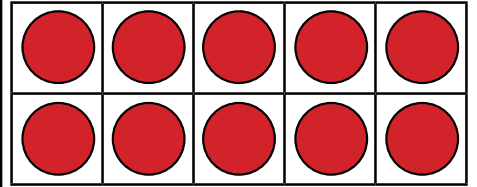

12

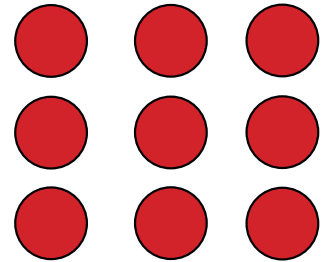
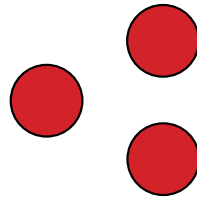

12

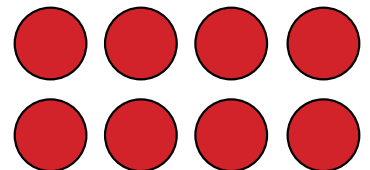
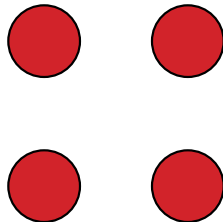

# Cartes de nombres de 0 à 100

0

1

2

3



# Cartes de nombres de 0 à 100

(suite)

4

5

6

7



# Cartes de nombres de 0 à 100

(suite)

8

9

10

11





# Cartes de nombres de 0 à 100

(suite)

12

13

14

15



# Cartes de nombres de 0 à 100

(suite)

16

17

18

19



# Cartes de nombres de 0 à 100

(suite)

20

21

22

23



# Cartes de nombres de 0 à 100

(suite)

24

25

26

27



# Cartes de nombres de 0 à 100

(suite)

28

29

30

31



# Cartes de nombres de 0 à 100

(suite)

32

33

34

35



# Cartes de nombres de 0 à 100

(suite)

36

37

38

39



# Cartes de nombres de 0 à 100

(suite)

40

41

42

43





# Cartes de nombres de 0 à 100

(suite)

44

45

46

47



# Cartes de nombres de 0 à 100

(suite)

48

49

50

51



# Cartes de nombres de 0 à 100

(suite)

52

53

54

55



# Cartes de nombres de 0 à 100

(suite)

56

57

58

59



# Cartes de nombres de 0 à 100

(suite)

60

61

62

63



# Cartes de nombres de 0 à 100

(suite)

64

65

66

67



# Cartes de nombres de 0 à 100

(suite)

68

69

70

71



# Cartes de nombres de 0 à 100

(suite)

72

73

74

75





# Cartes de nombres de 0 à 100

(suite)

76

77

78

79



# Cartes de nombres de 0 à 100

(suite)

80

81

82

83



# Cartes de nombres de 0 à 100

(suite)

84

85

86

87

# Cartes de nombres de 0 à 100

(suite)

88

89

90

91



# Cartes de nombres de 0 à 100

(suite)

92

93

94

95



# Cartes de nombres de 0 à 100

(suite)

96

97

98

99



# Cartes de nombres de 0 à 100

(suite)

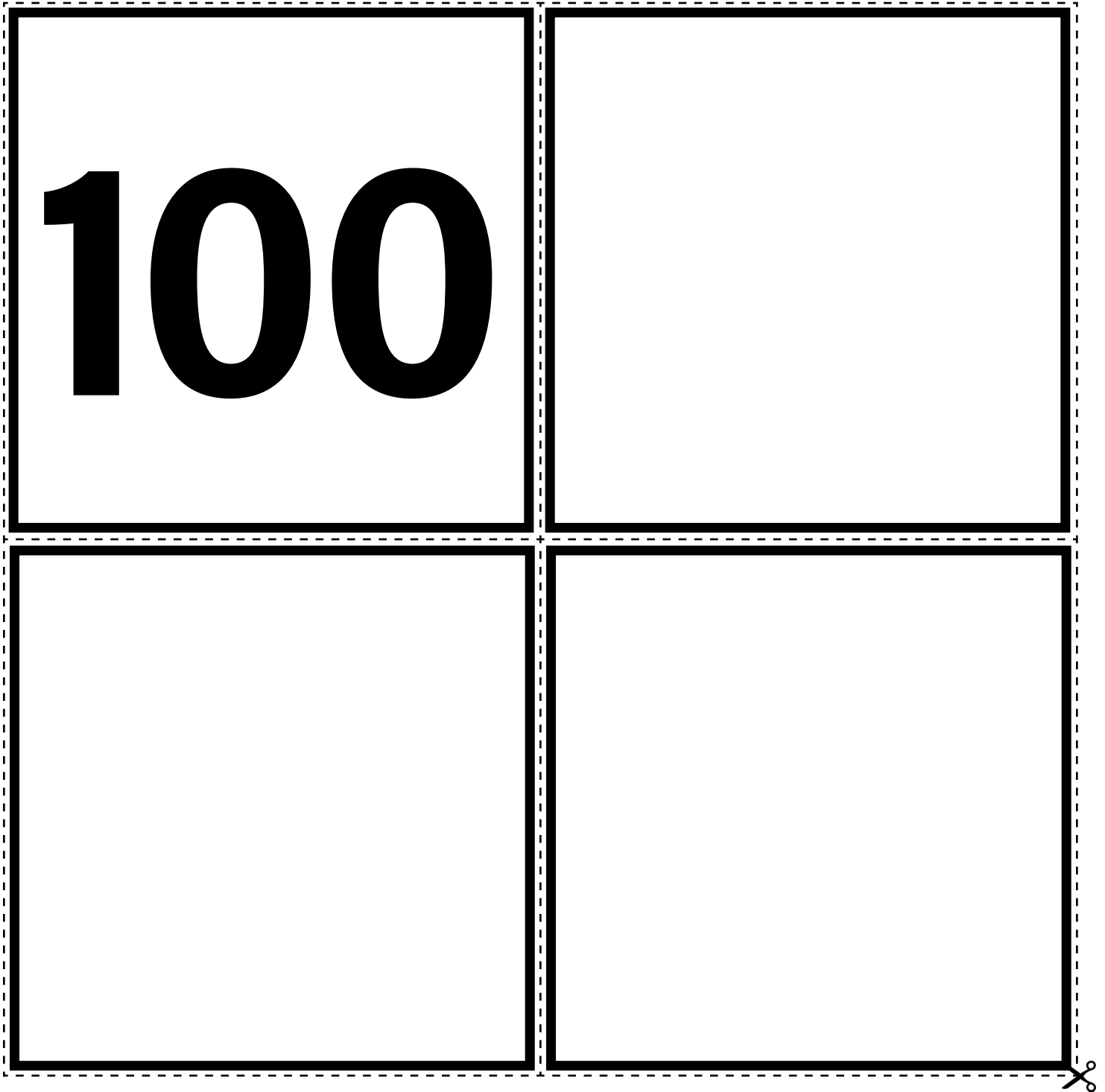



# Cartes de symboles d'opérations

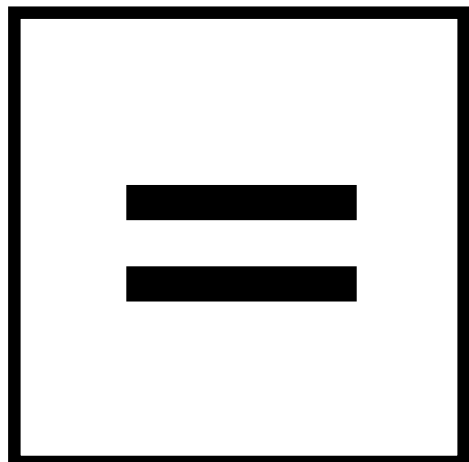
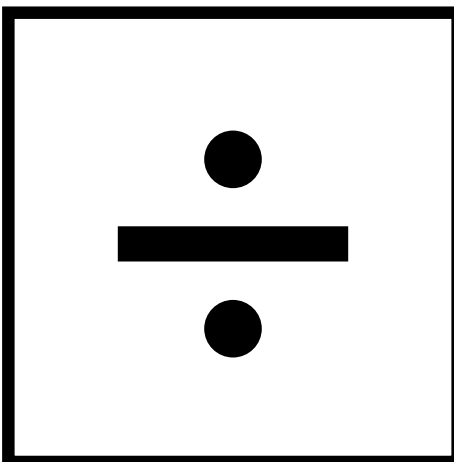
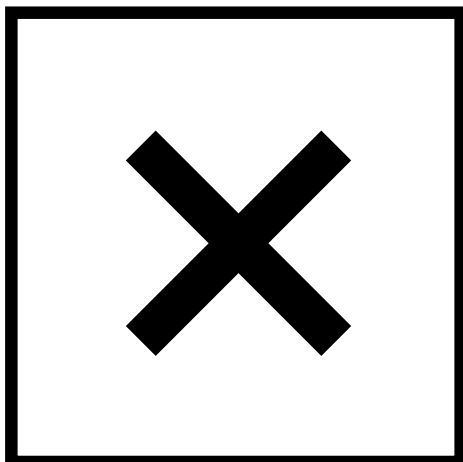
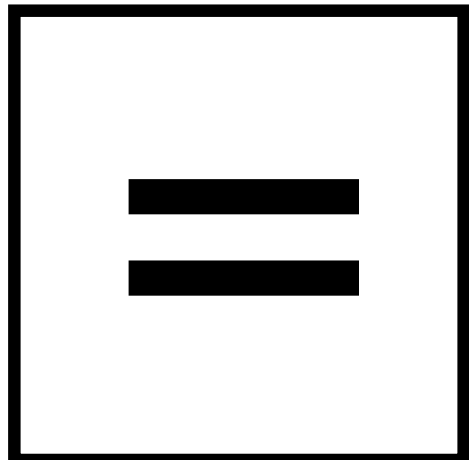
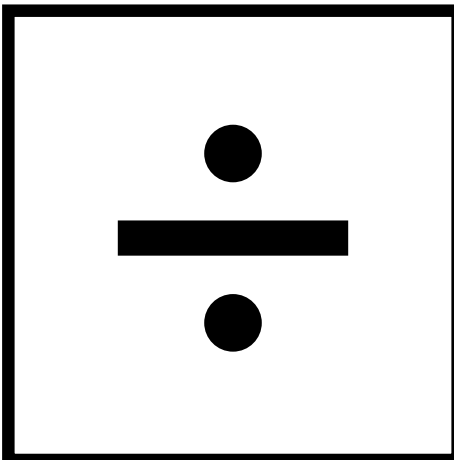
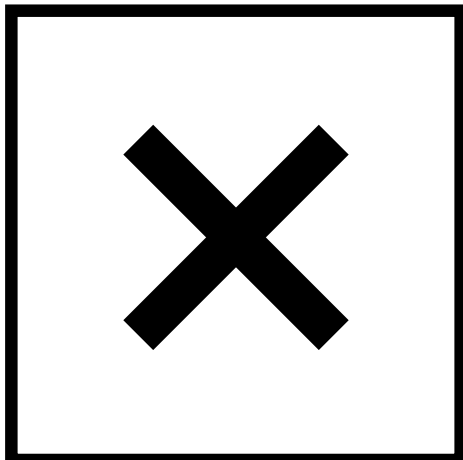
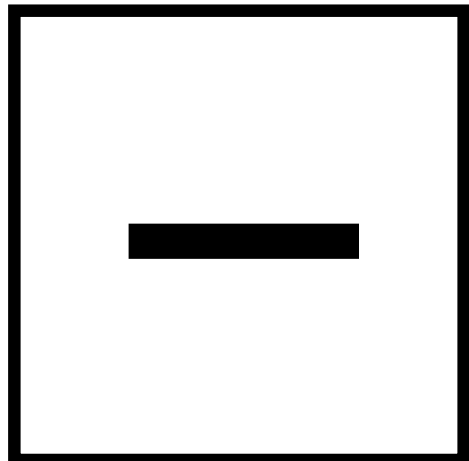
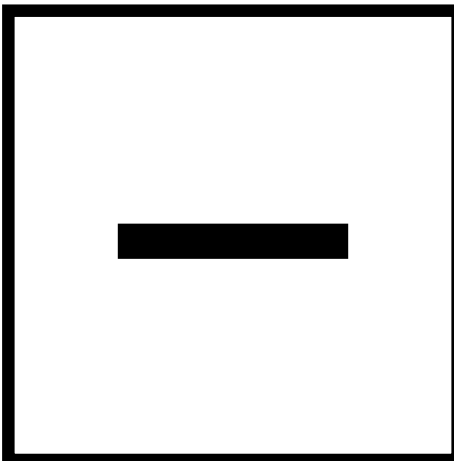
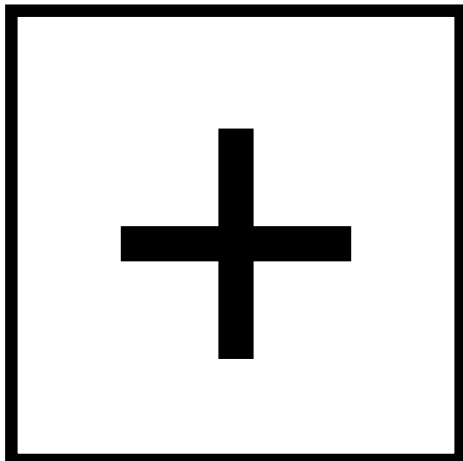
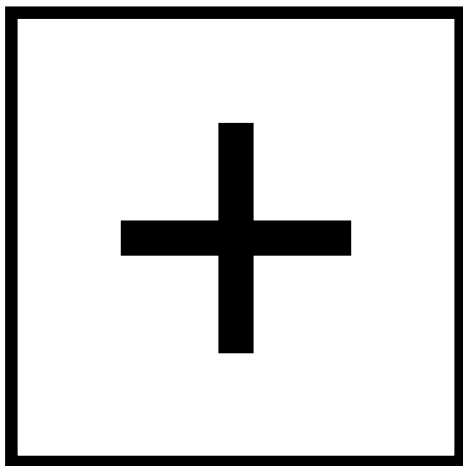



### Cartes de reconnaissance globale avec les doigts de la main (1 à 10)



# Cartes de reconnaissance globale avec les doigts de la main (1 à 10) (suite)

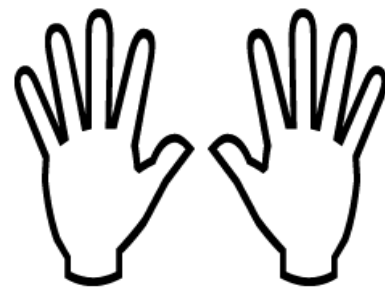
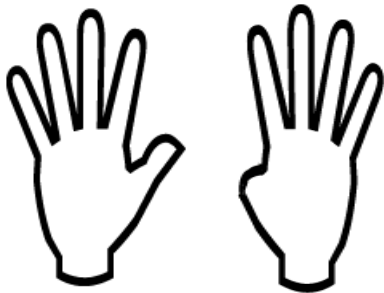
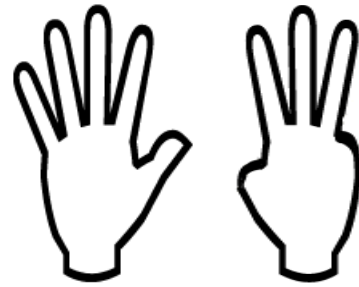
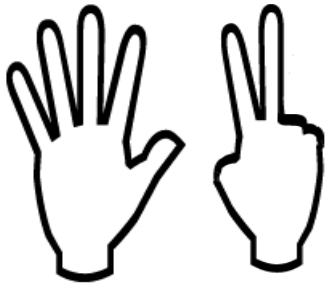

## Cartes de reconnaissance globale avec les doigts de la main (1 à 10)



# Cartes de reconnaissance globale avec les doigts de la main (1 à 10)

(suite)

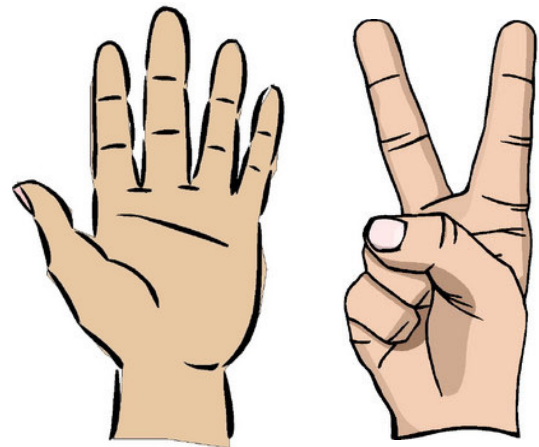
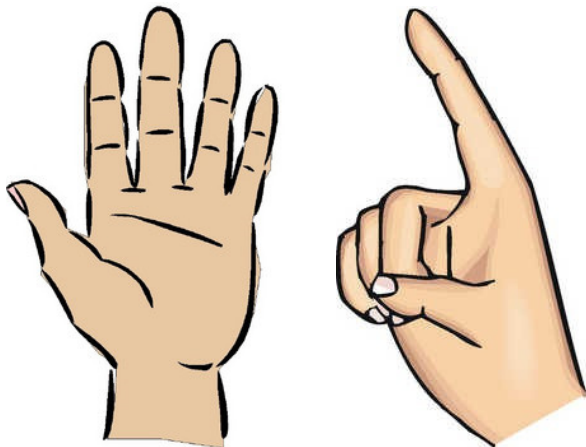

# Cartes de reconnaissance globale avec les doigts de la main (1 à 10) (suite)

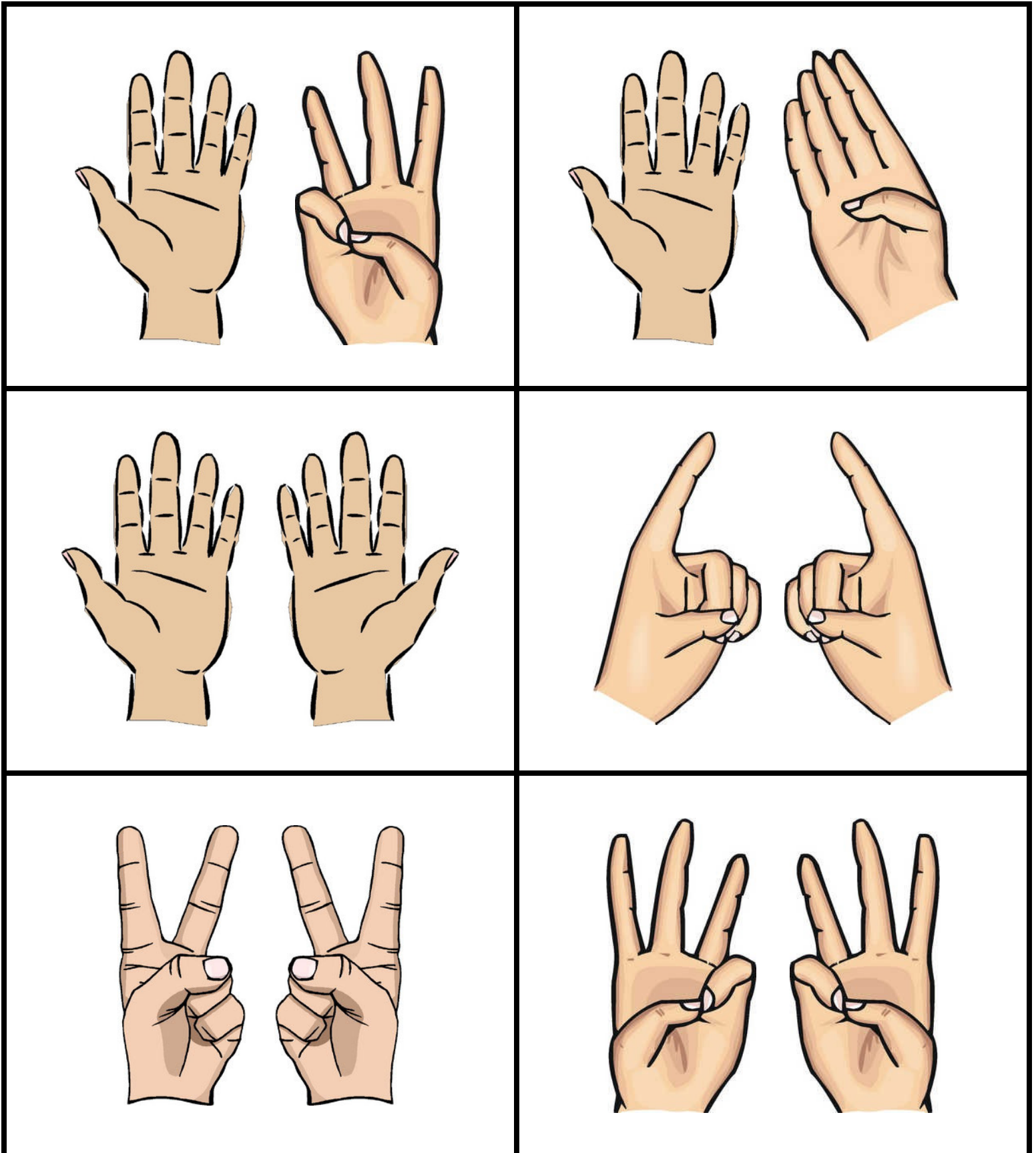

# Cartes de reconnaissance globale avec les doigts de la main (1 à 10)

(suite)

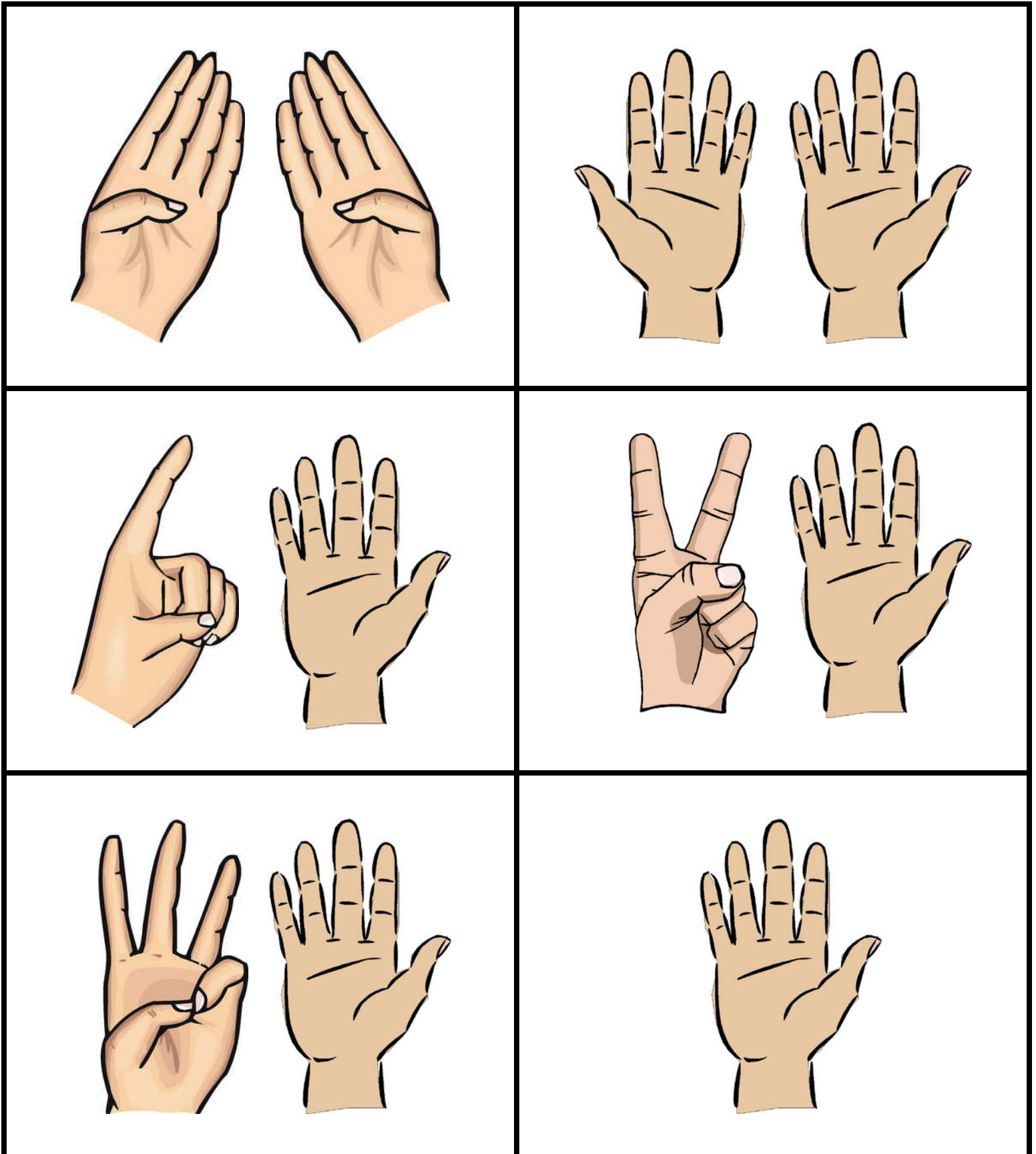

# Constellations de points familiers et non familiers (1 à 10)

## Format rectangulaire



# Constellations de points familiers et non familiers (1 à 10)

## Format rectangulaire (suite)



The image displays four rectangular panels, each containing a different constellation of three black dots. The panels are arranged in a 2x2 grid and are separated by dashed lines. A scissors icon is located at the top right corner of the grid, indicating that the panels should be cut out.

- Top-left panel: Three dots arranged in a triangle with one dot at the top and two at the bottom.
- Top-right panel: Three dots arranged in a vertical line.
- Bottom-left panel: Three dots arranged in a diagonal line from top-left to bottom-right.
- Bottom-right panel: Three dots arranged in a triangle with one dot at the top and two at the bottom.





# Constellations de points familiers et non familiers (1 à 10)

## Format rectangulaire (suite)



The image shows four rectangular boxes arranged in a 2x2 grid, each containing a different arrangement of four black dots. The boxes are separated by dashed lines, and a scissors icon is in the top right corner of the grid.

- Top-left box:** Four dots arranged in a 2x2 square pattern.
- Top-right box:** Four dots arranged in a descending staircase pattern from top-left to bottom-right.
- Bottom-left box:** Three dots in a vertical column on the left side, and one dot to the right of the middle dot.
- Bottom-right box:** Three dots in a horizontal row at the bottom, and one dot centered above the middle dot.



# Constellations de points familiers et non familiers (1 à 10)

## Format rectangulaire (suite)

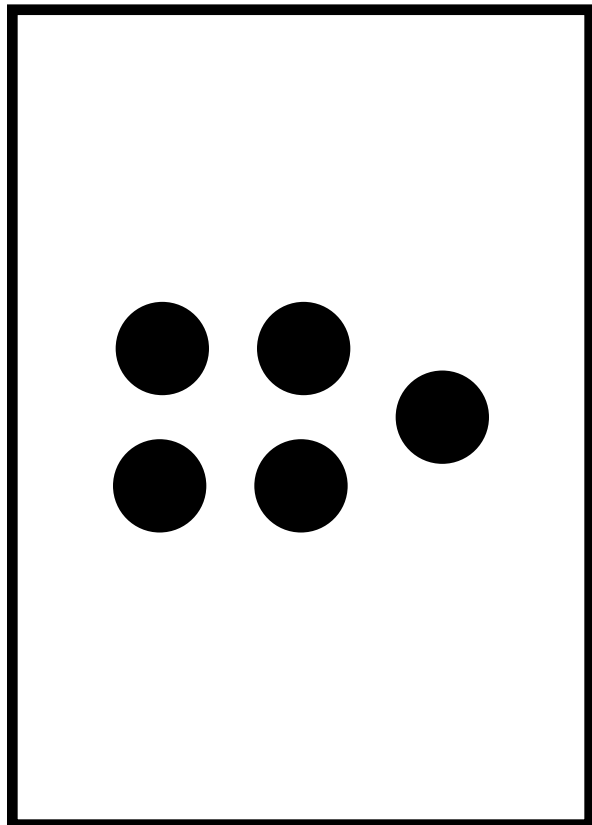
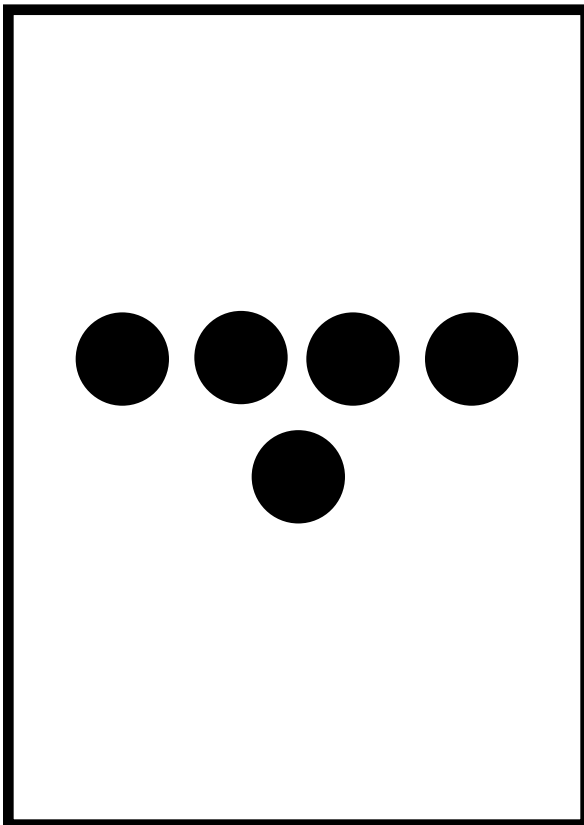
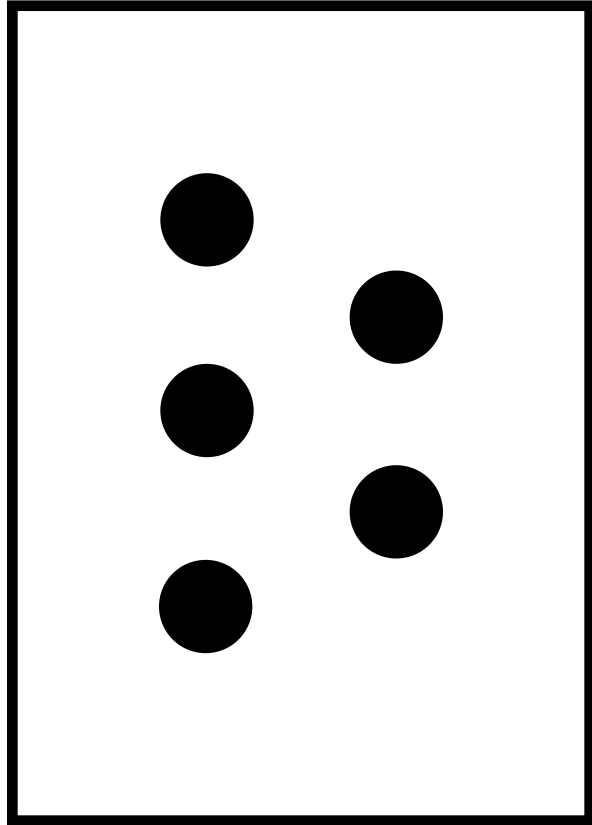
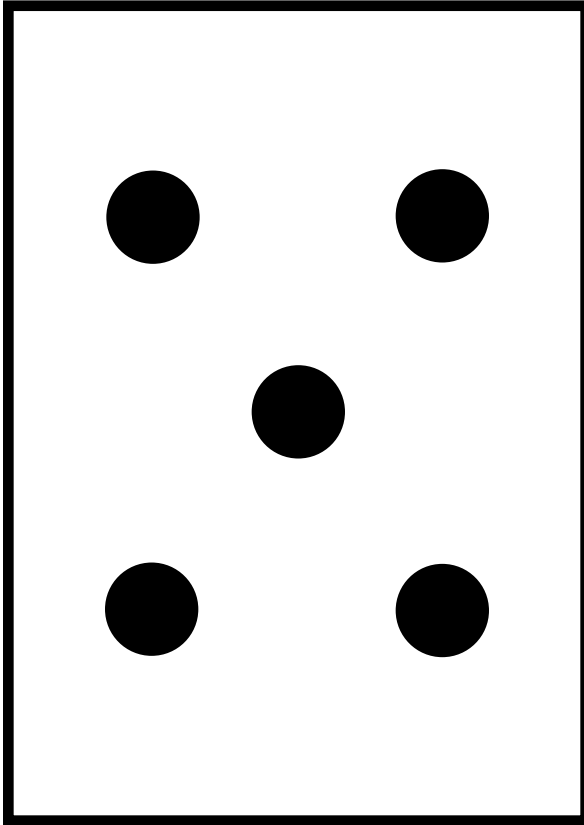

# Constellations de points familiers et non familiers (1 à 10)

## Format rectangulaire (suite)

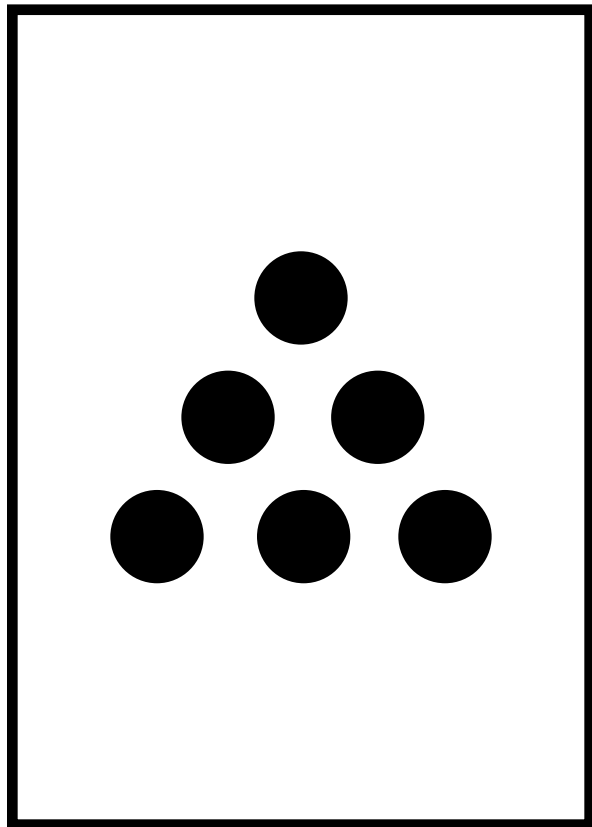
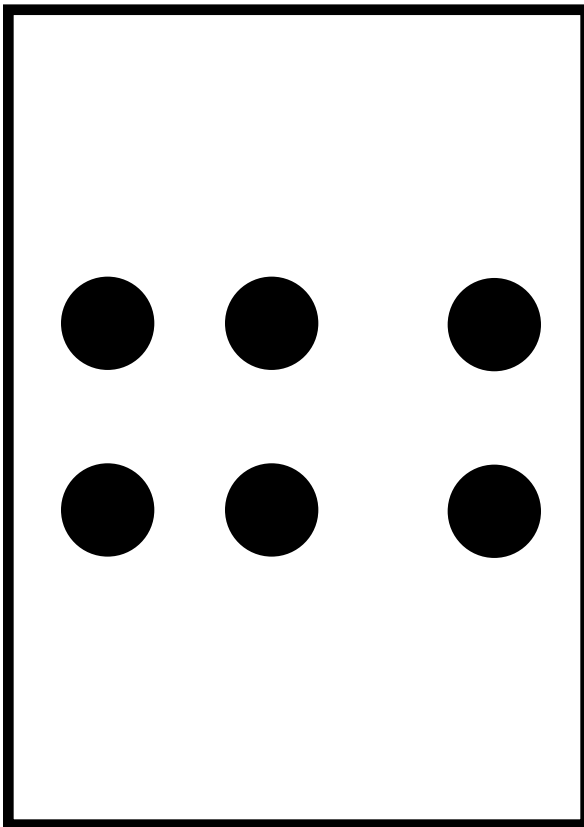
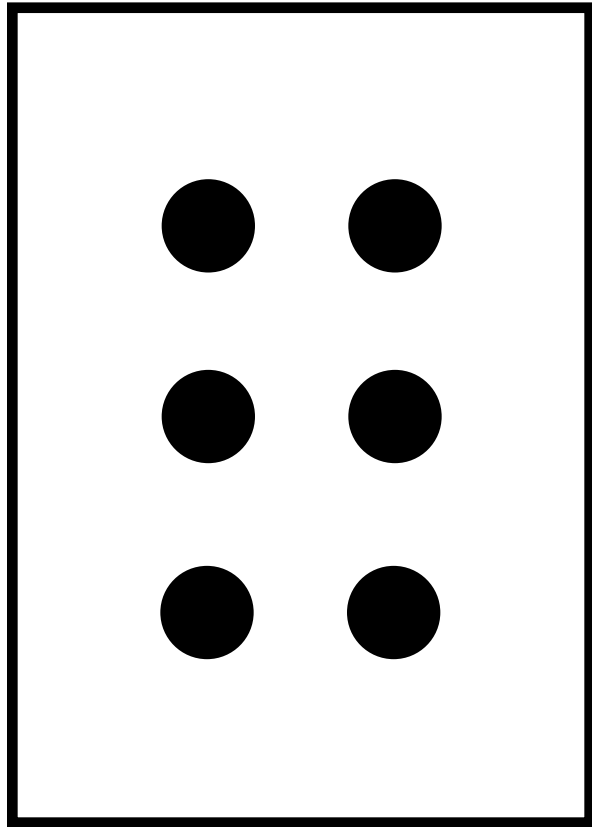
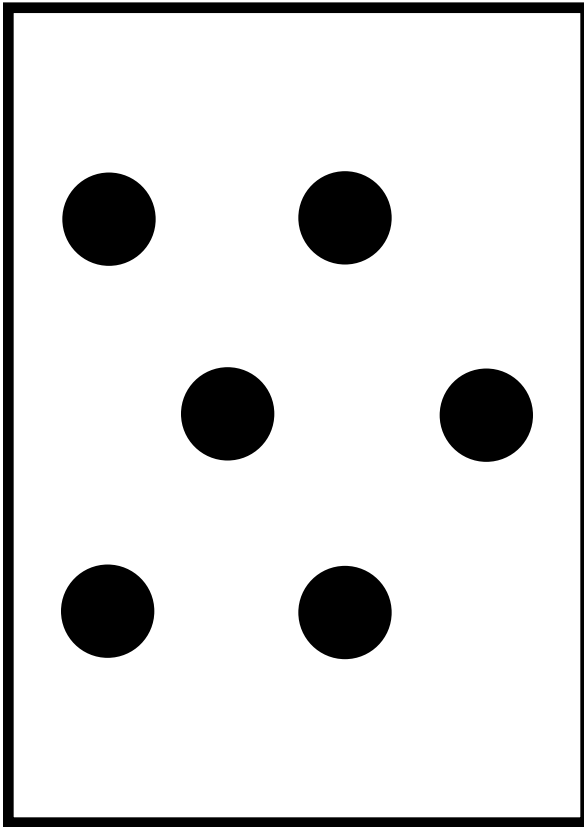

# Constellations de points familiers et non familiers (1 à 10)

## Format rectangulaire (suite)

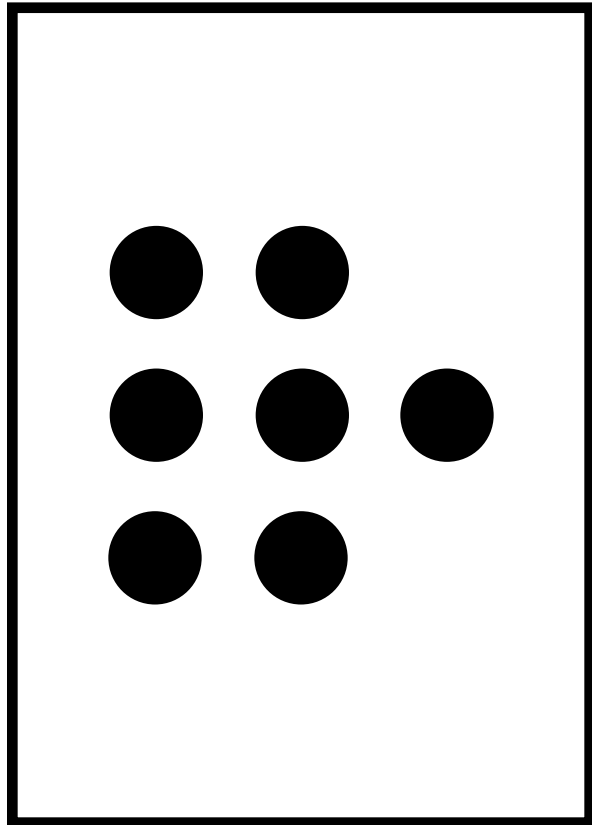
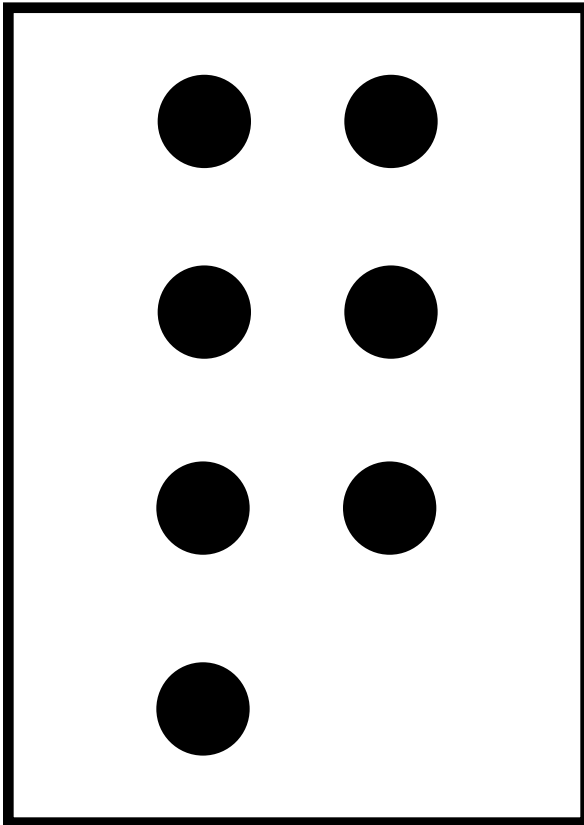
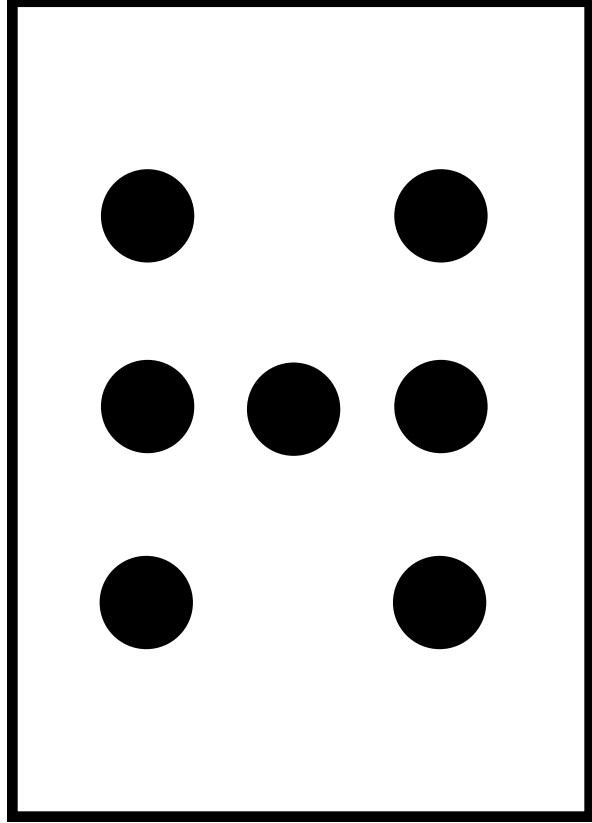
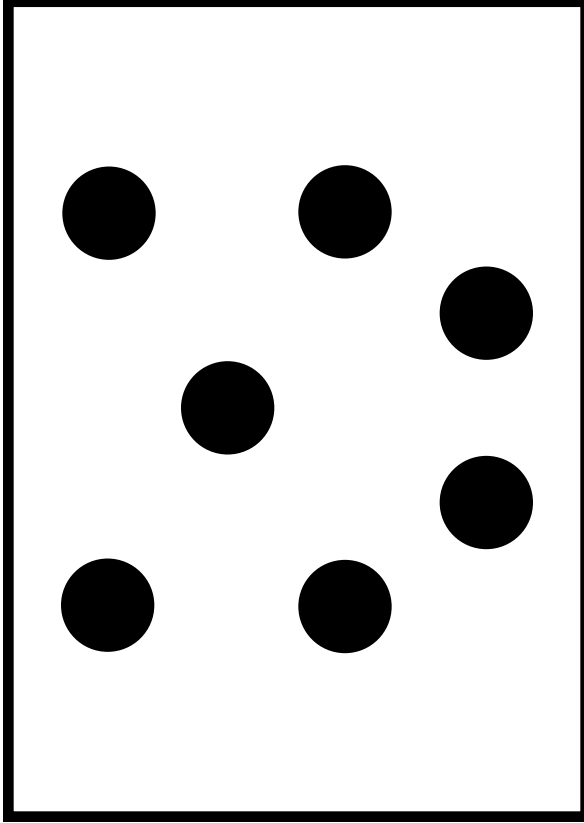

# Constellations de points familiers et non familiers (1 à 10)

## Format rectangulaire (suite)

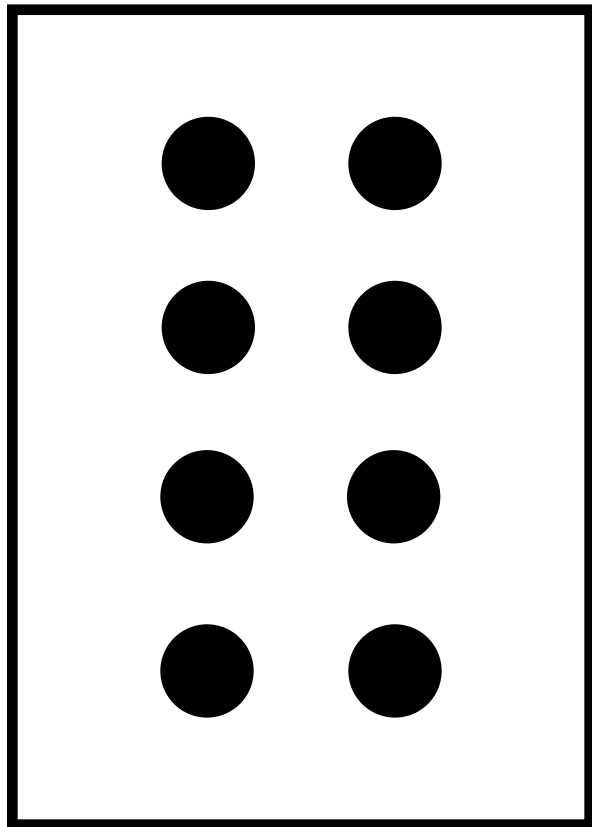
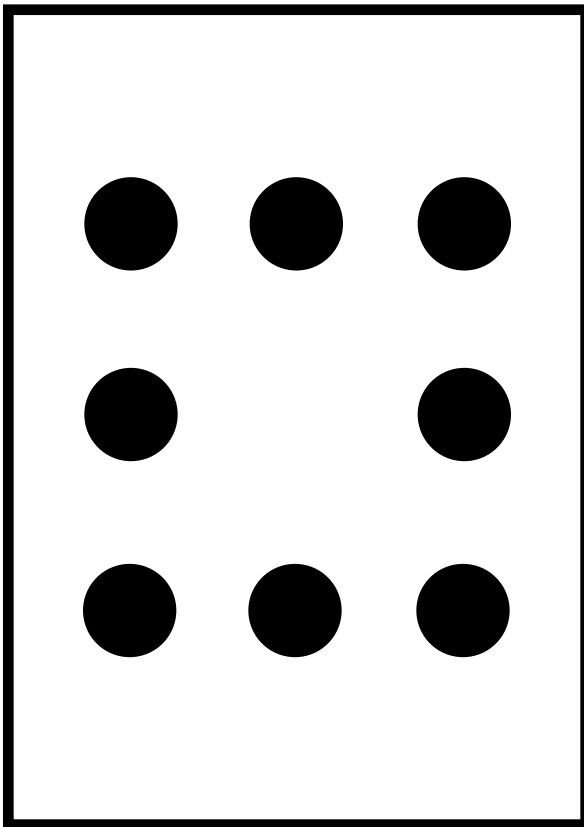
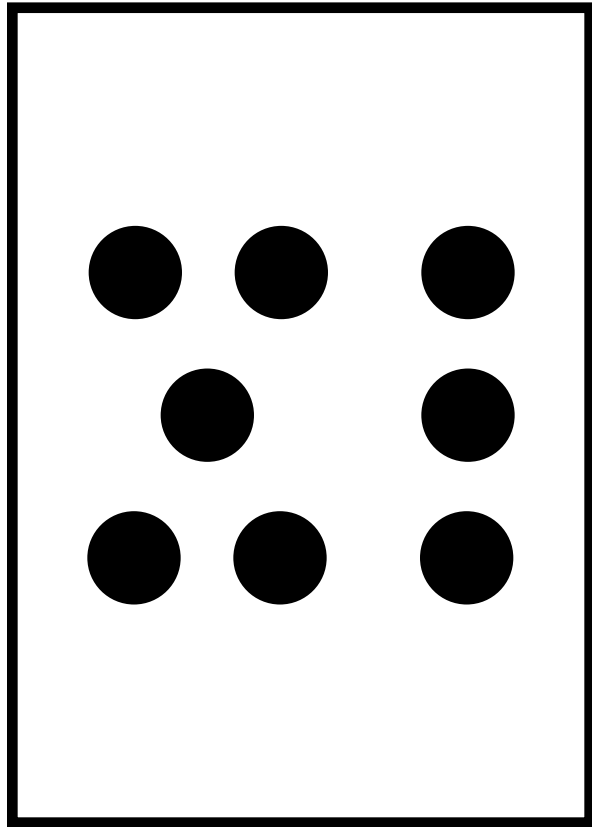
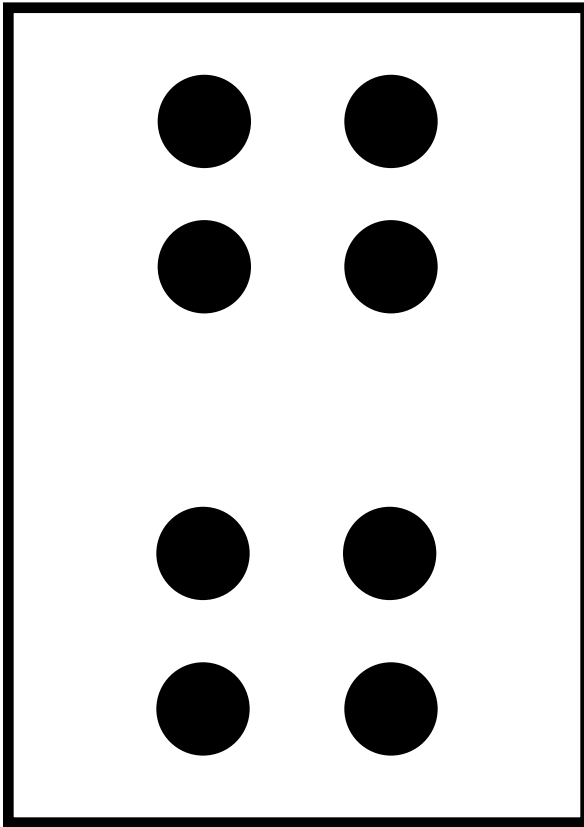

# Constellations de points familiers et non familiers (1 à 10)

## Format rectangulaire (suite)

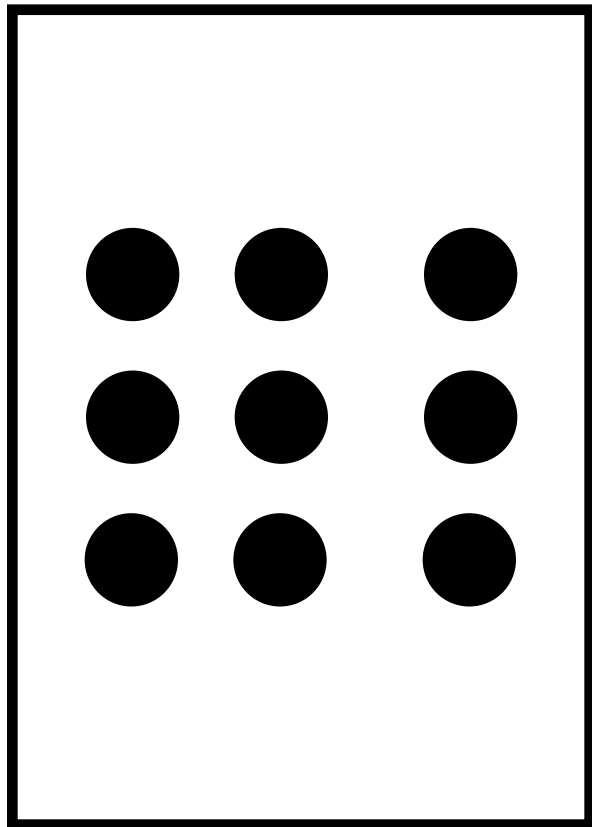
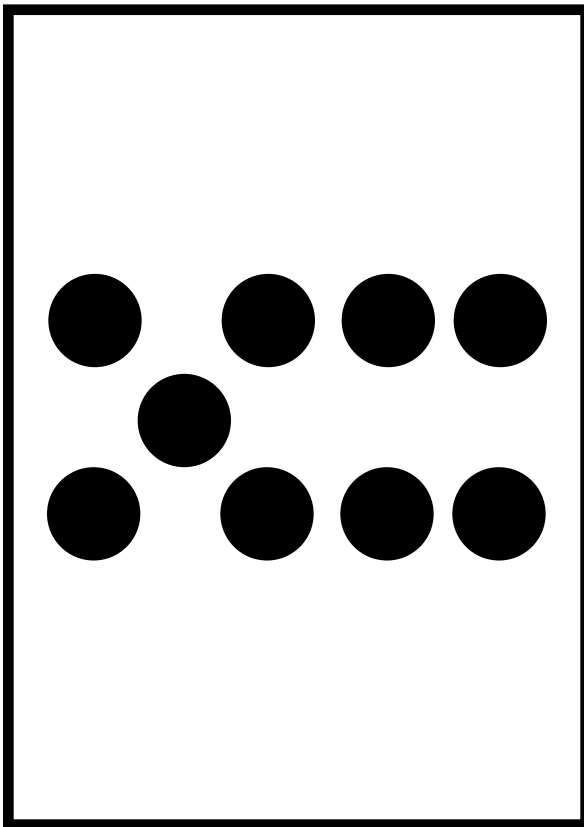
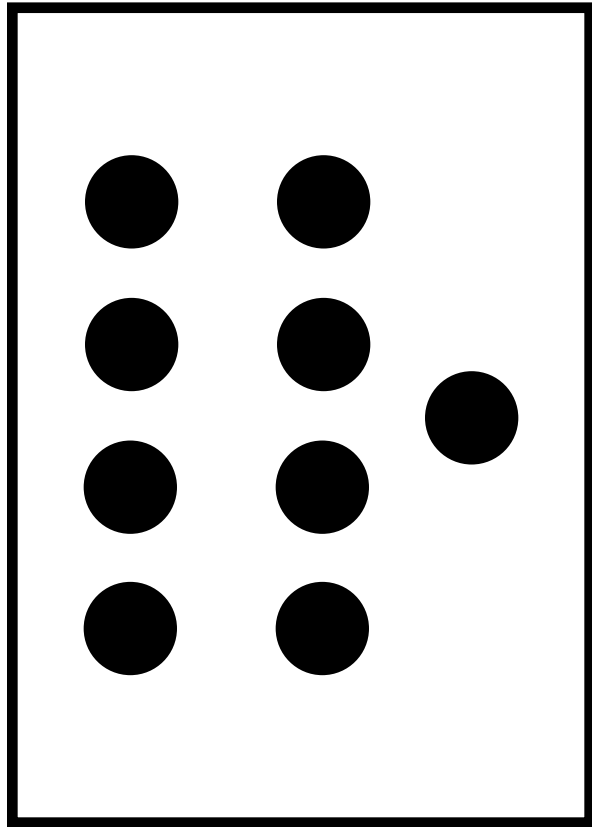
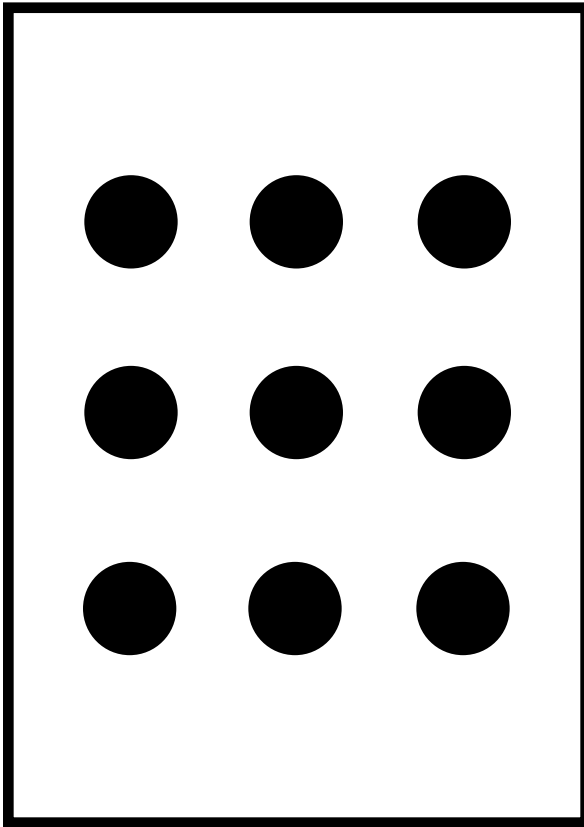

# Constellations de points familiers et non familiers (1 à 10)

## Format rectangulaire (suite)

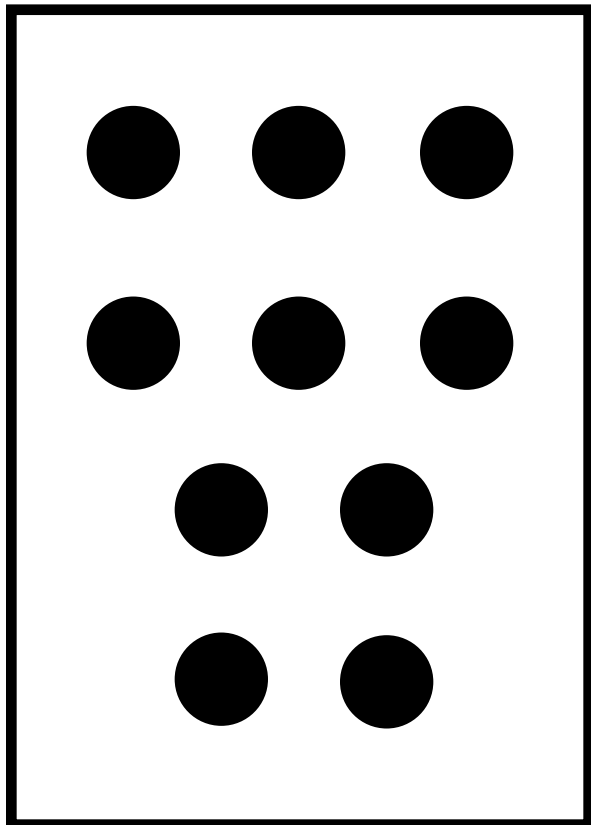
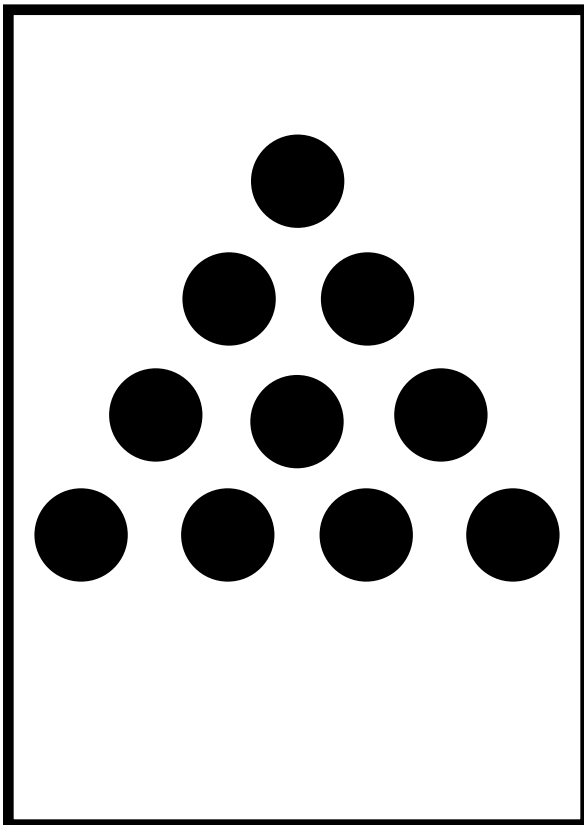
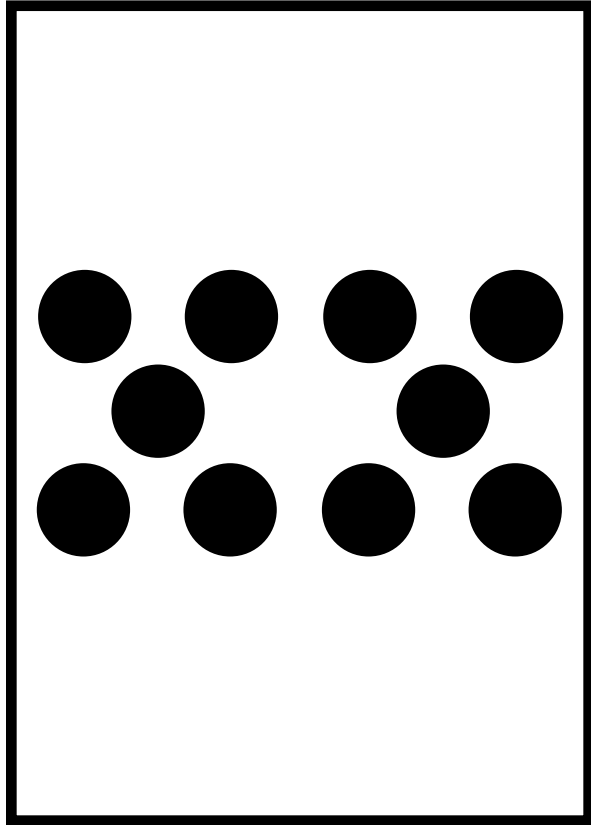
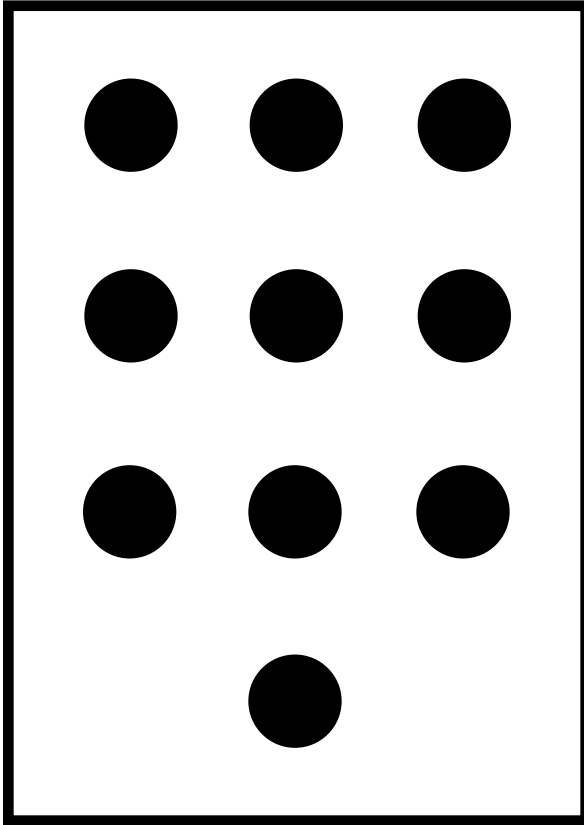

# Constellations de points familiers et non familiers (1 à 10)

## Format circulaire

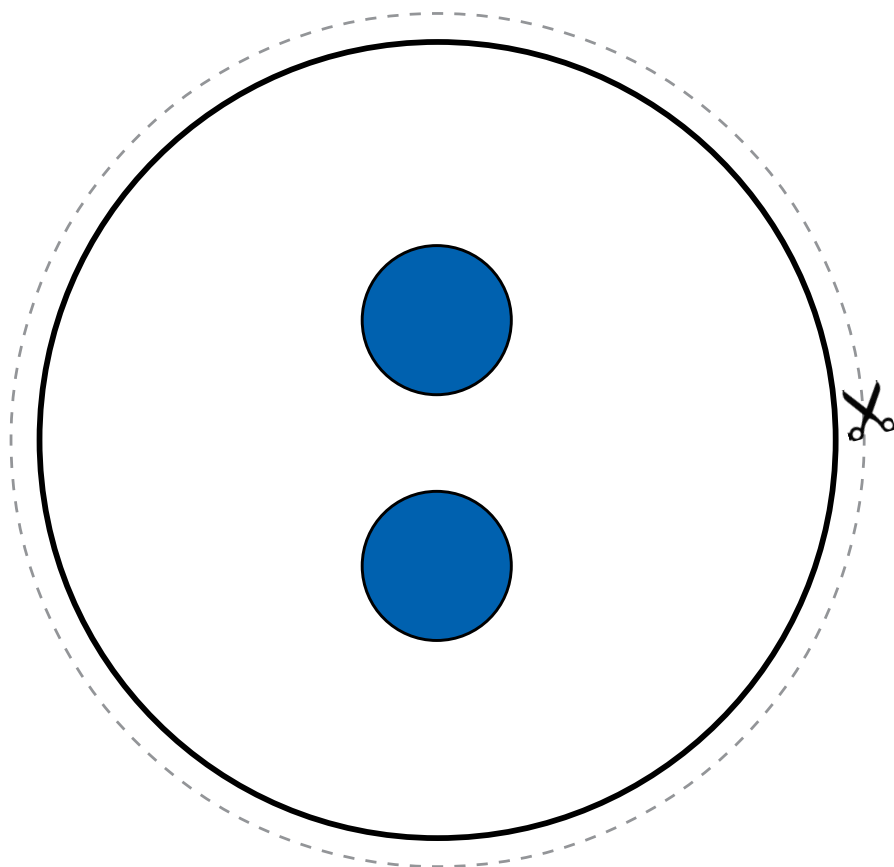
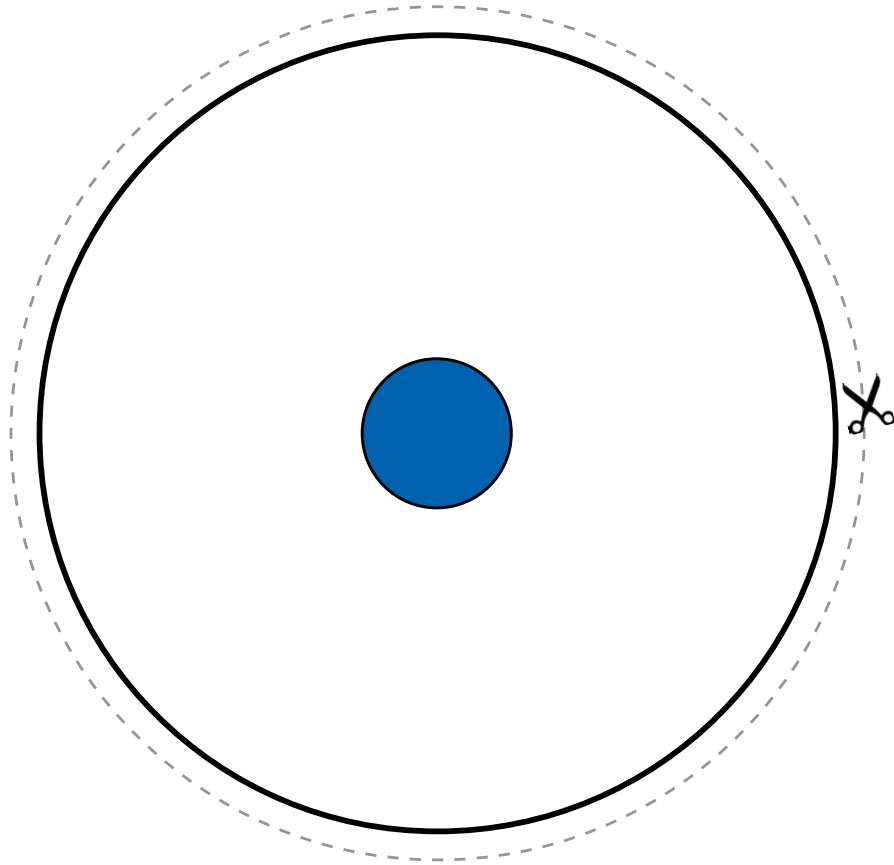



# Constellations de points familiers et non familiers (1 à 10)

## Format circulaire (suite)

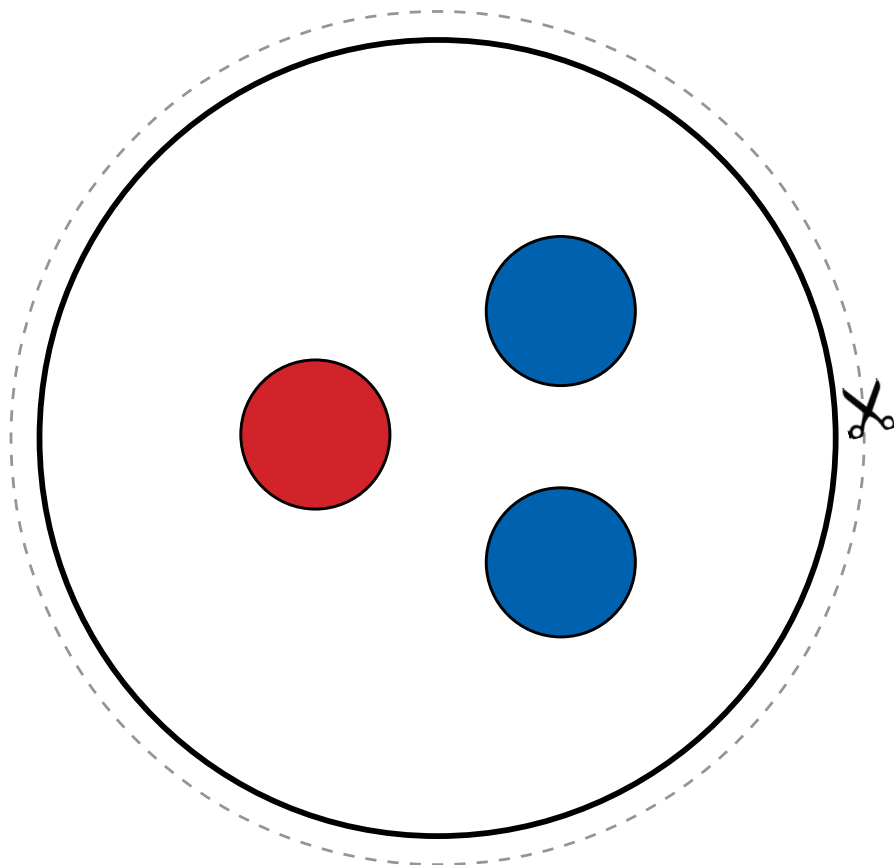
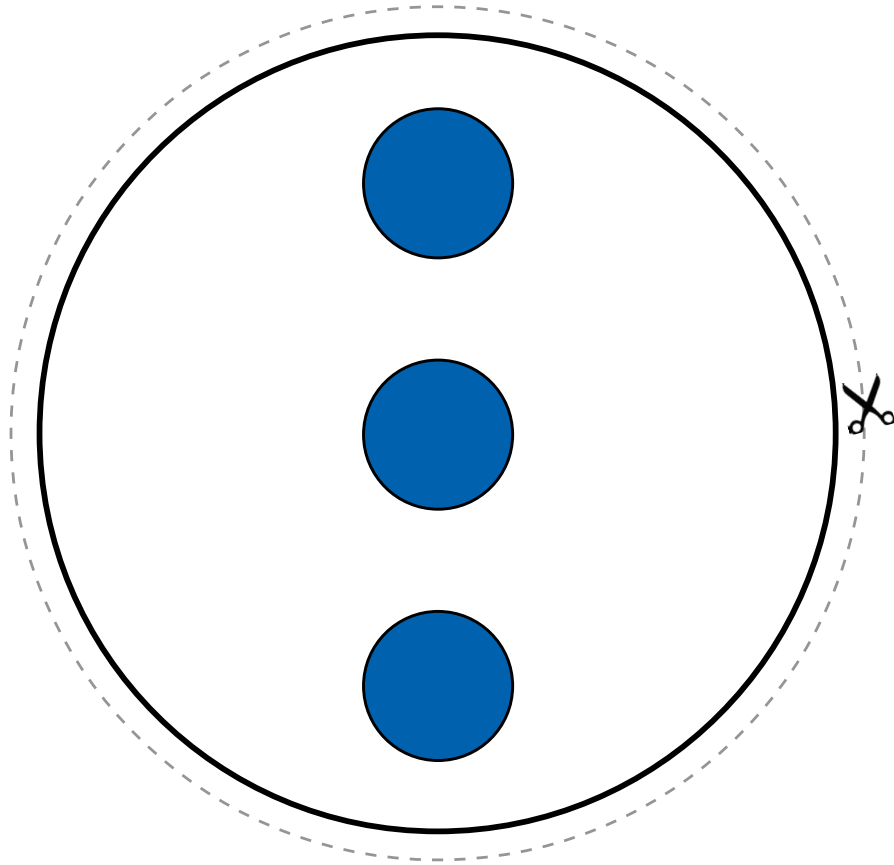

# Constellations de points familiers et non familiers (1 à 10)

## Format circulaire (suite)

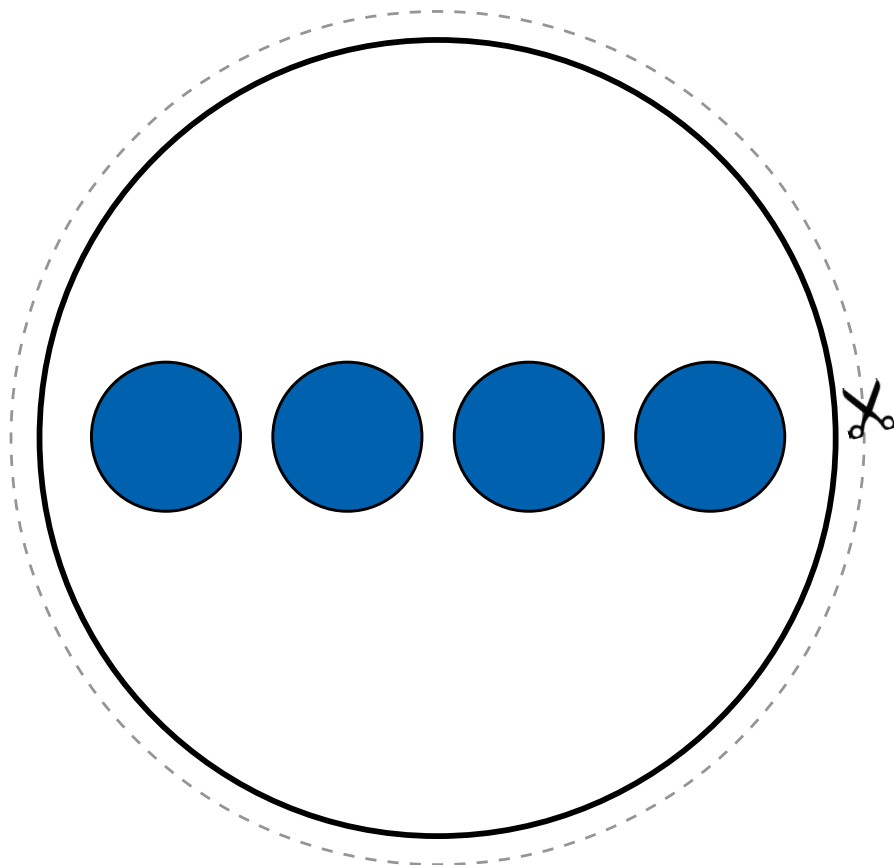
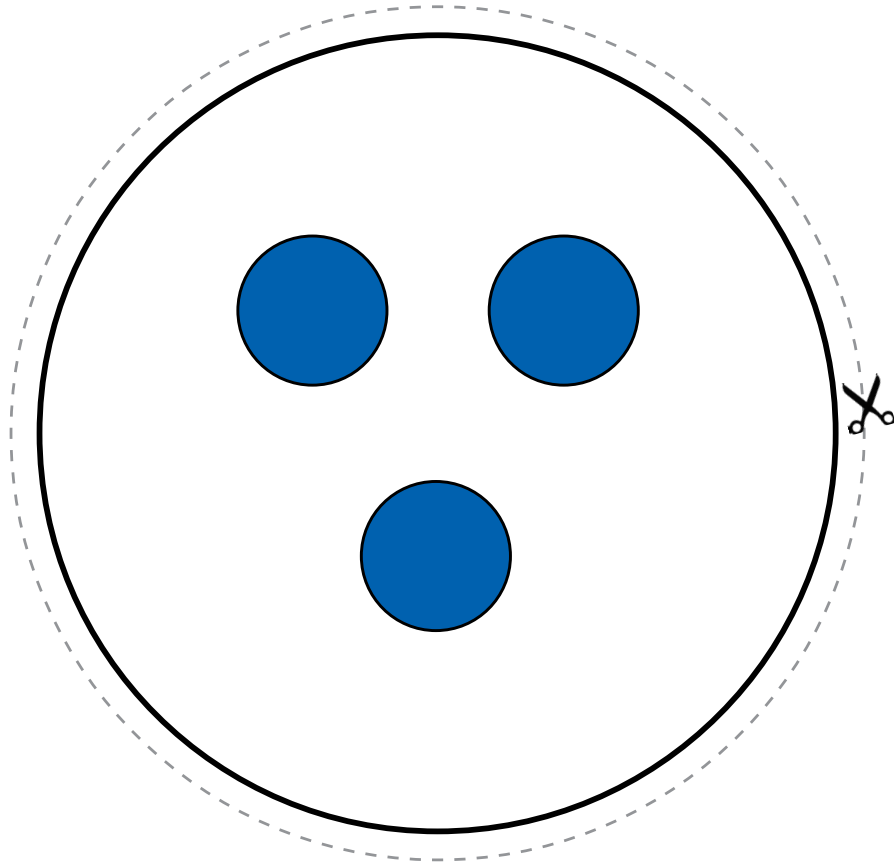

# Constellations de points familiers et non familiers (1 à 10)

## Format circulaire (suite)

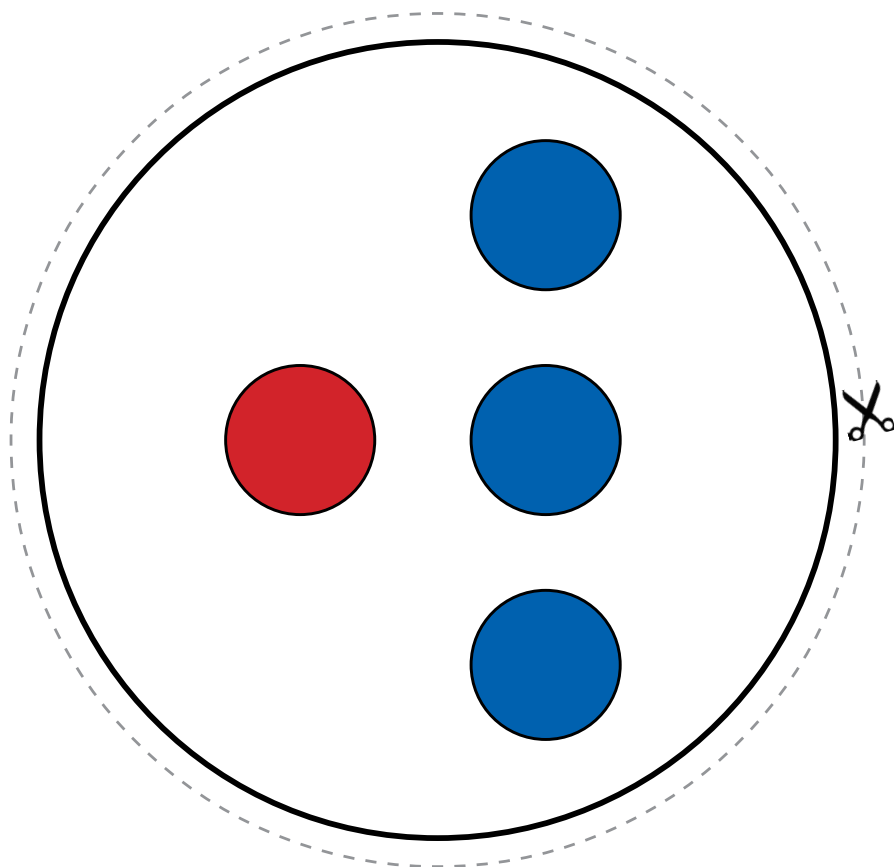
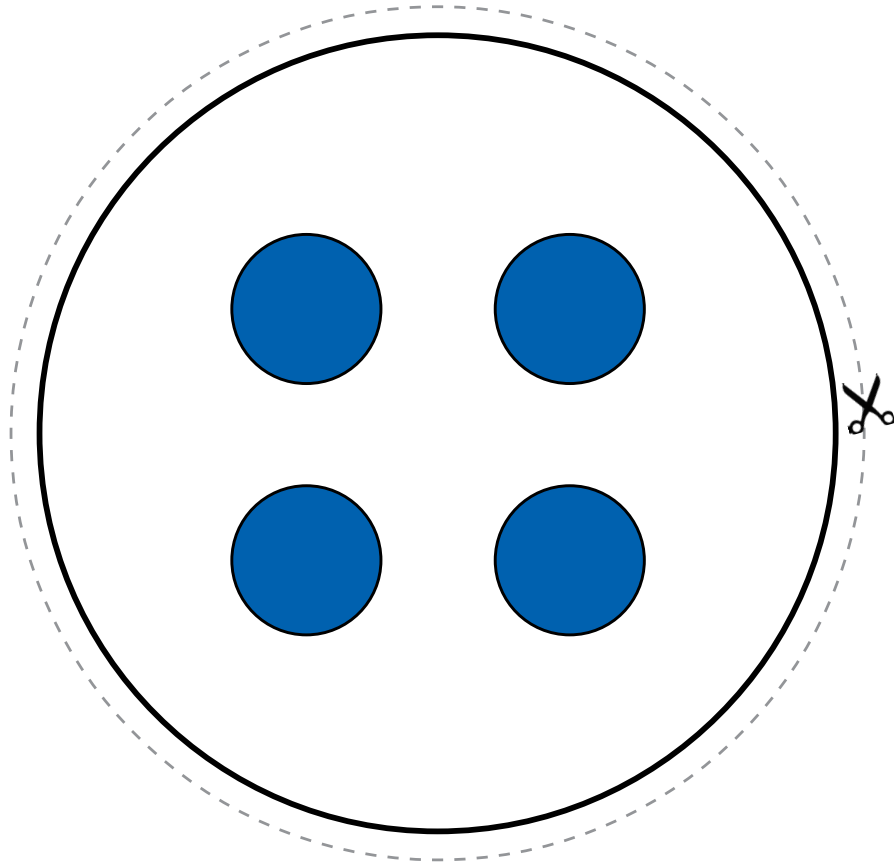

# Constellations de points familiers et non familiers (1 à 10)

## Format circulaire (suite)

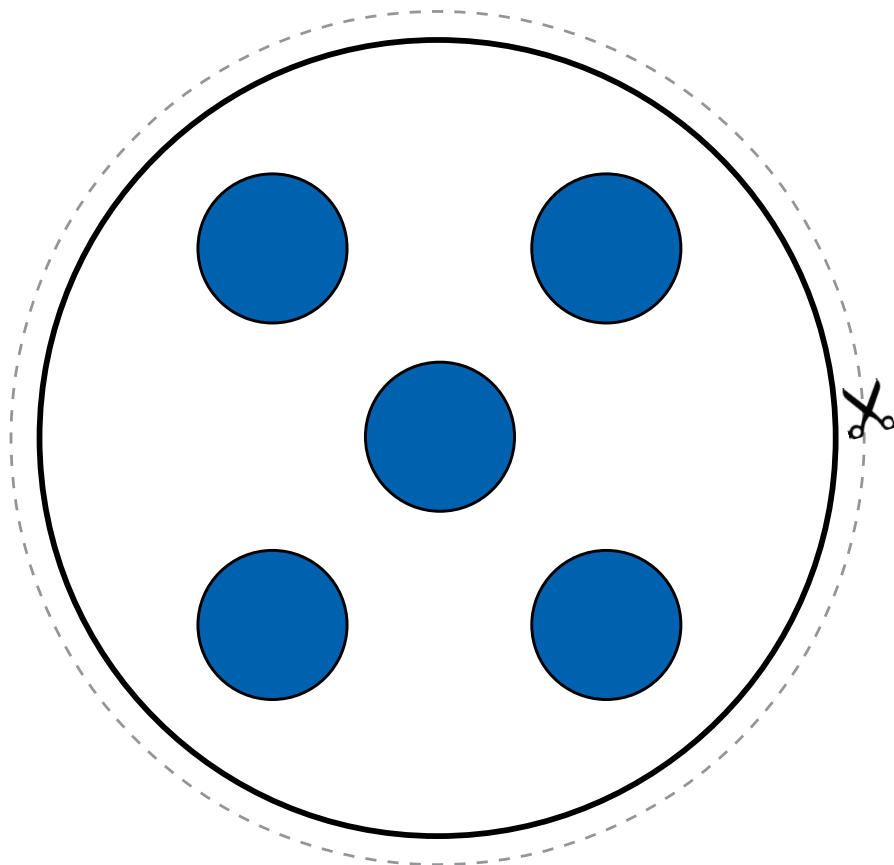
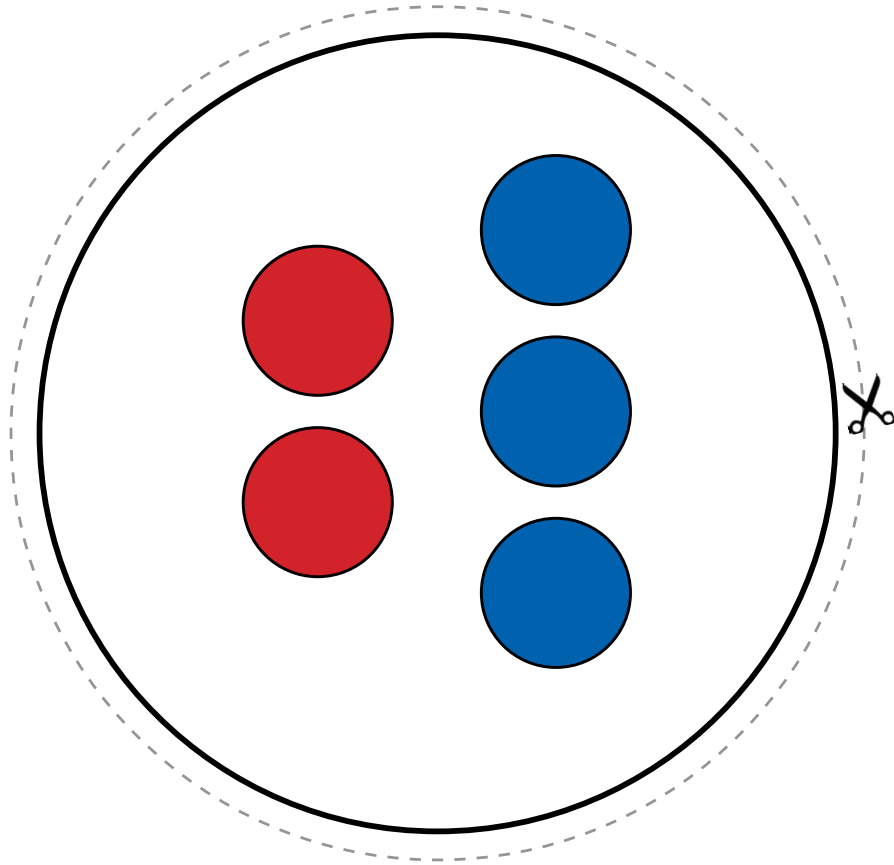

# Constellations de points familiers et non familiers (1 à 10)

## Format circulaire (suite)

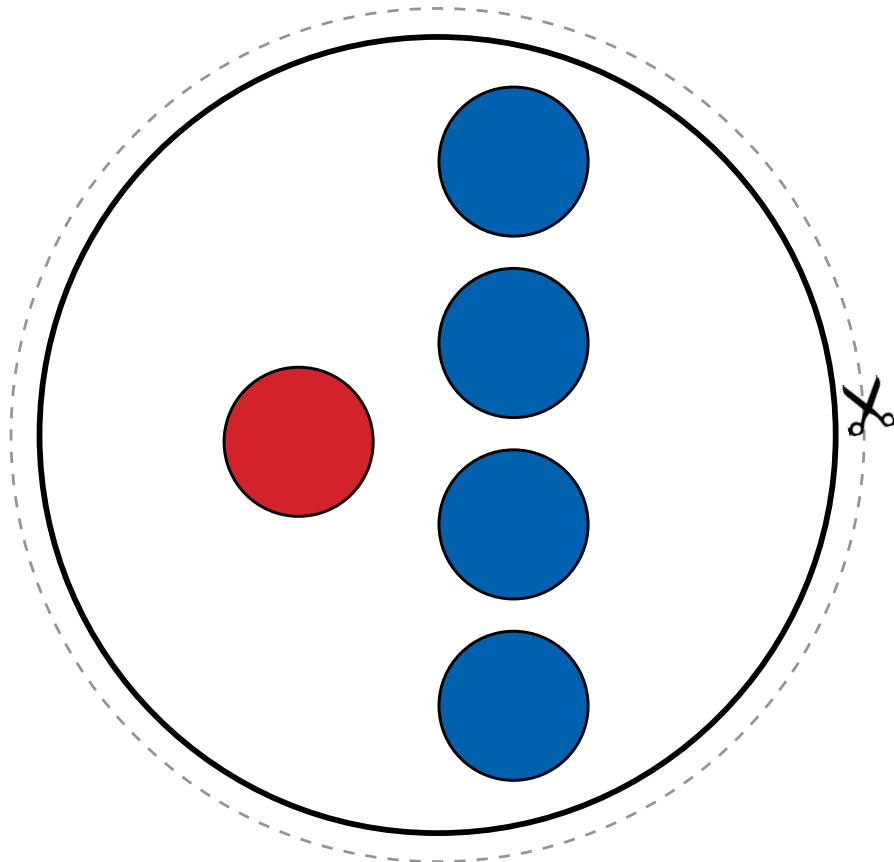
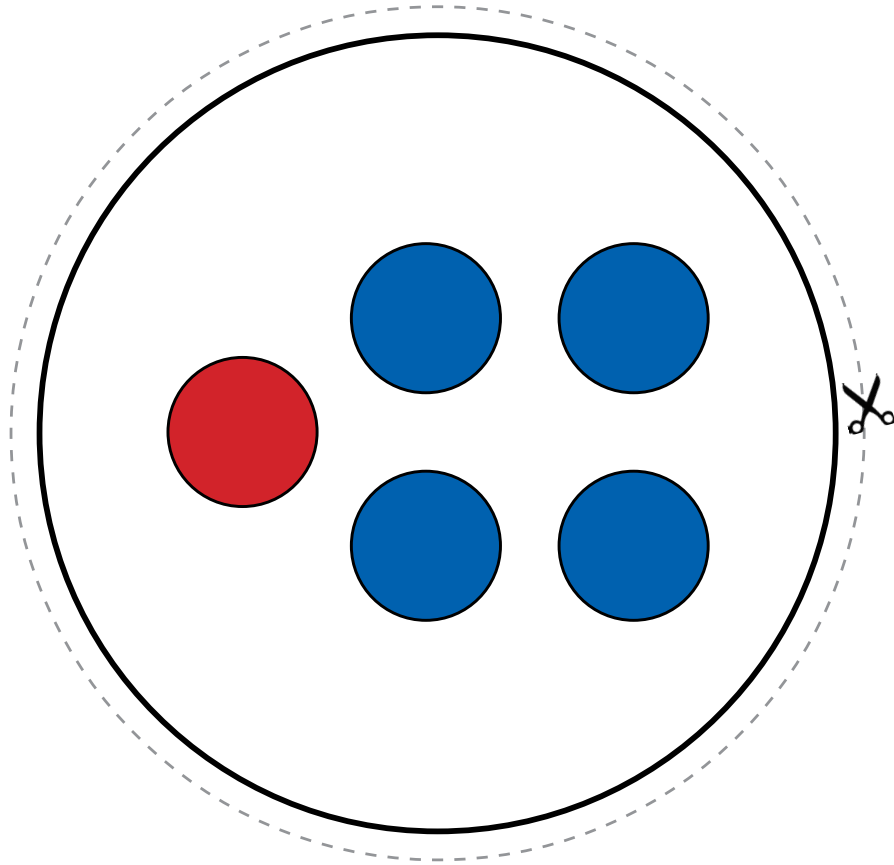

# Constellations de points familiers et non familiers (1 à 10)

## Format circulaire (suite)

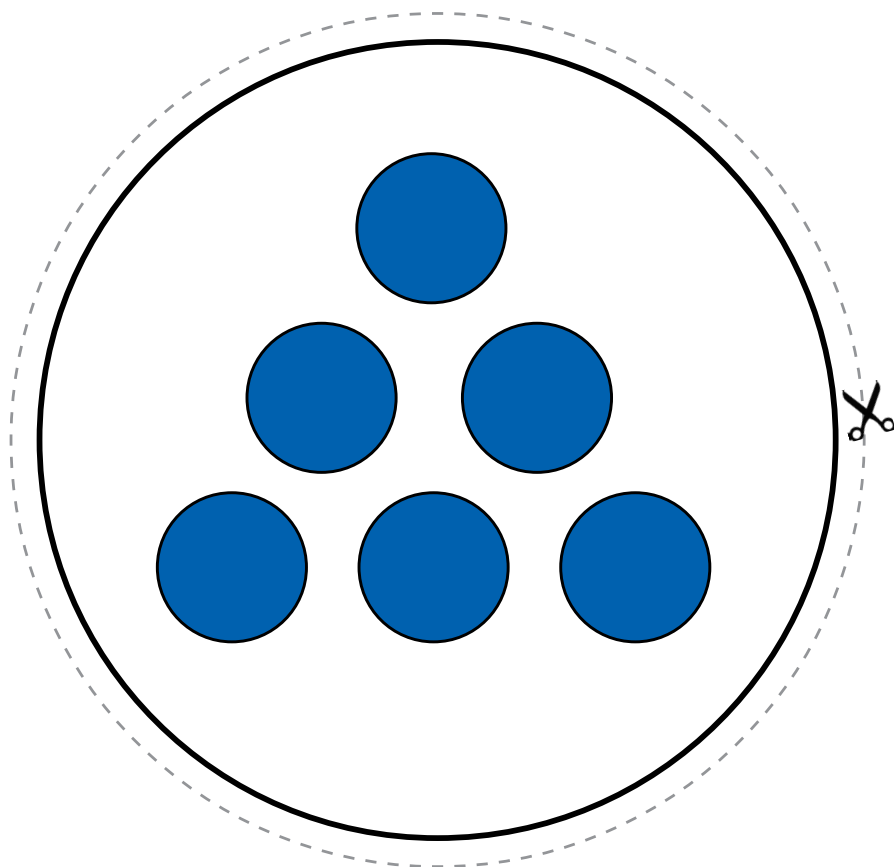
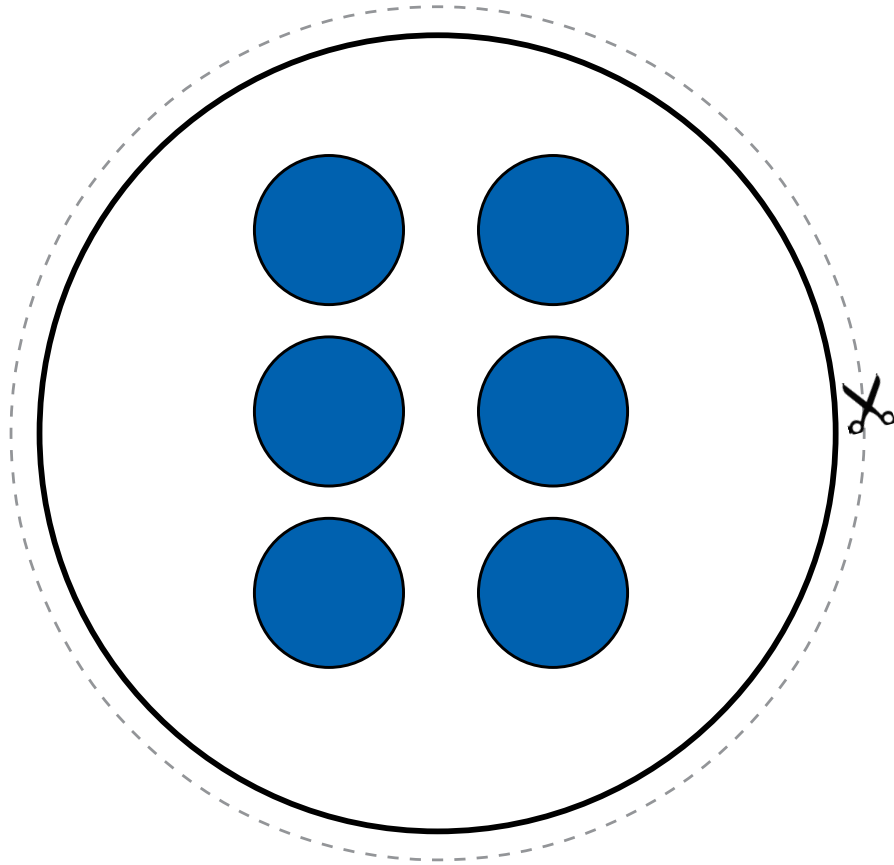

# Constellations de points familiers et non familiers (1 à 10)

## Format circulaire (suite)

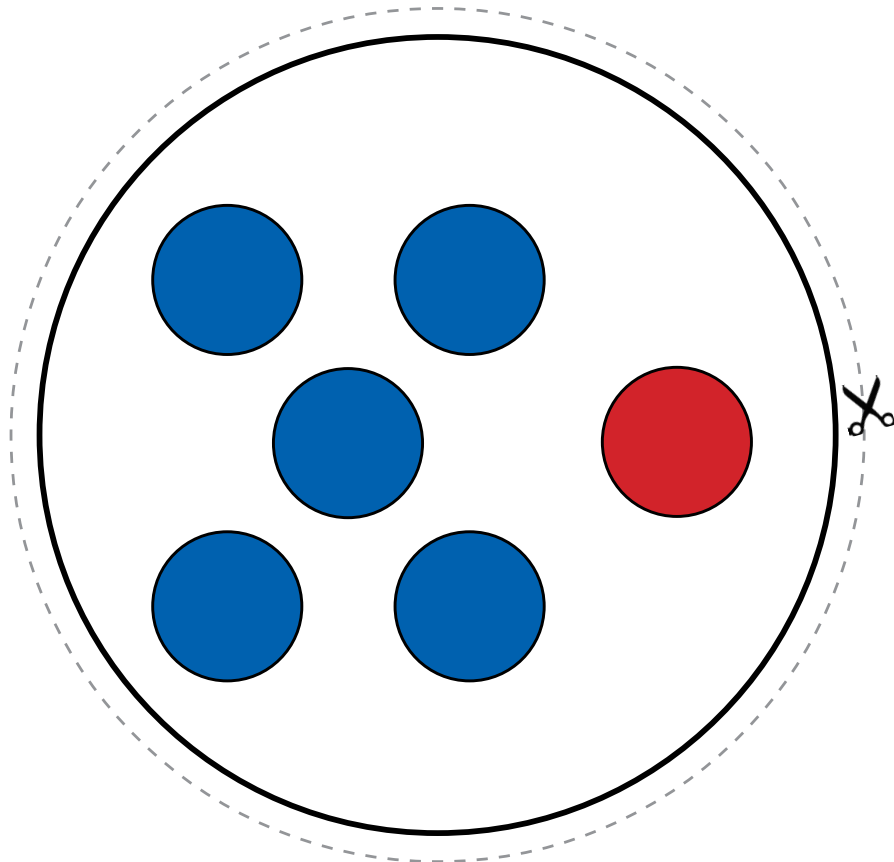
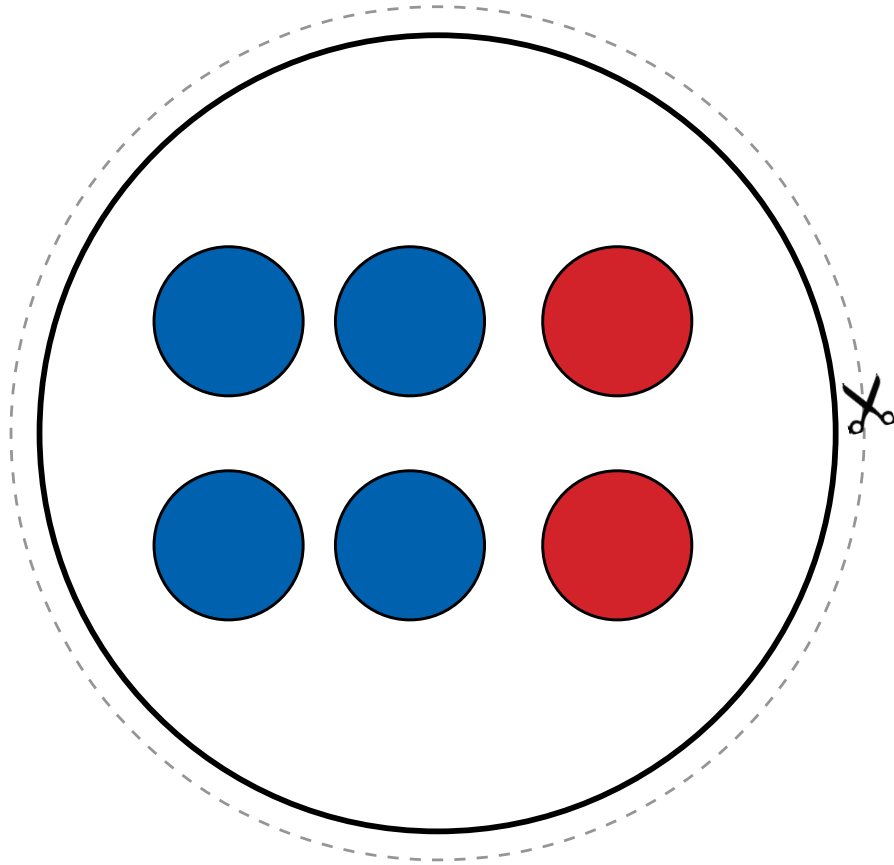

# Constellations de points familiers et non familiers (1 à 10)

## Format circulaire (suite)

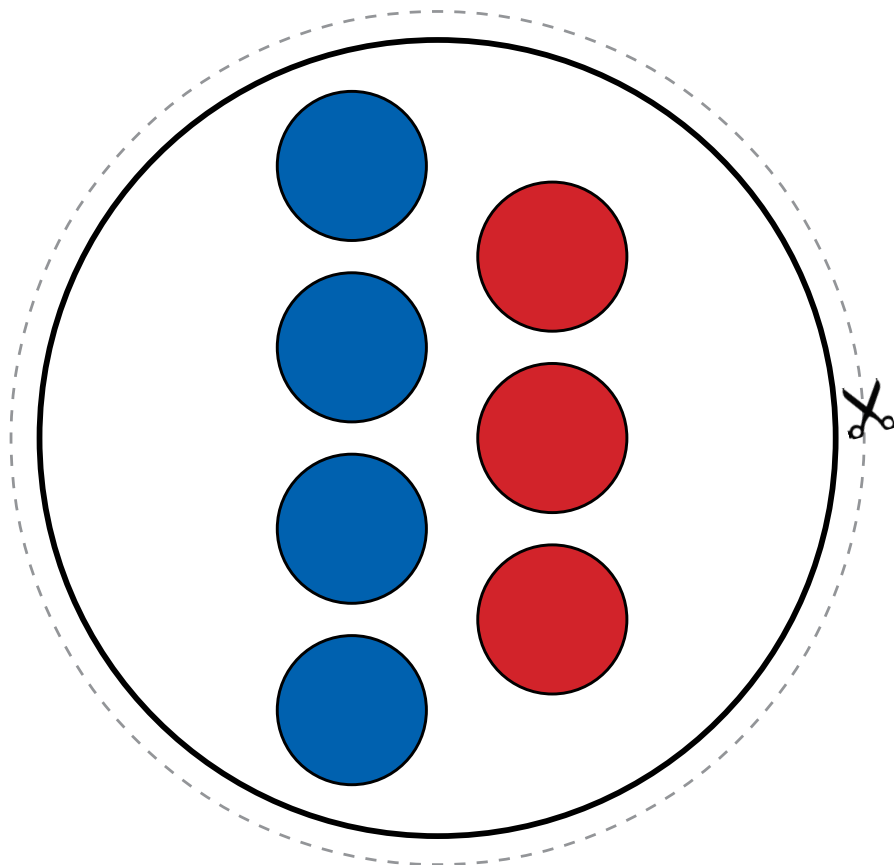
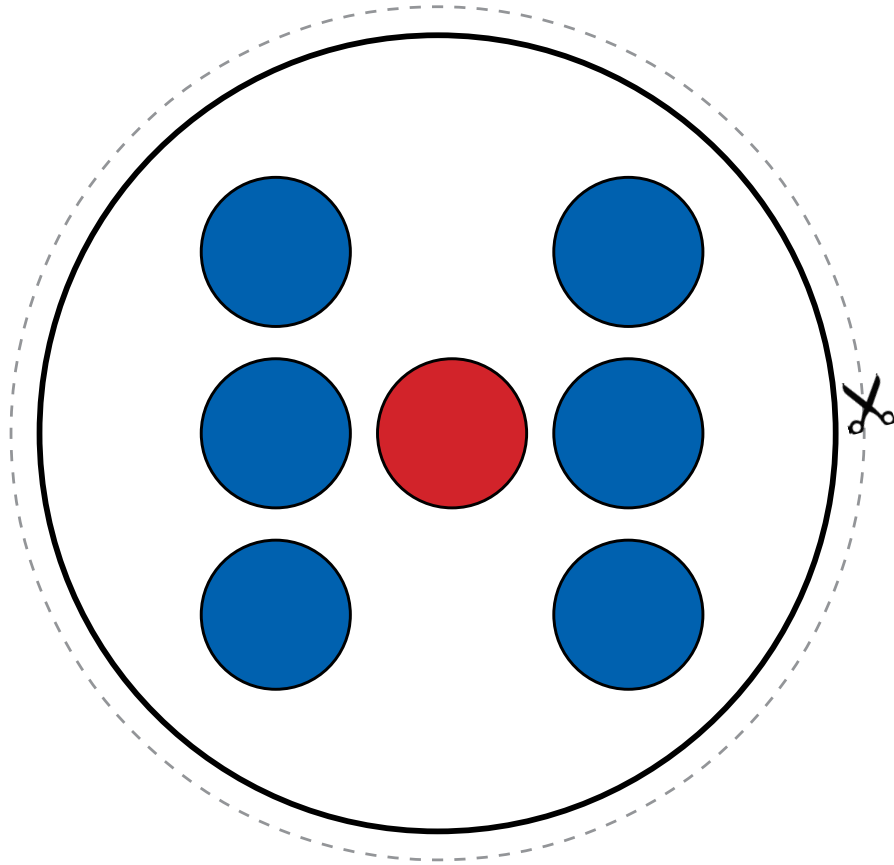



# Constellations de points familiers et non familiers (1 à 10)

## Format circulaire (suite)

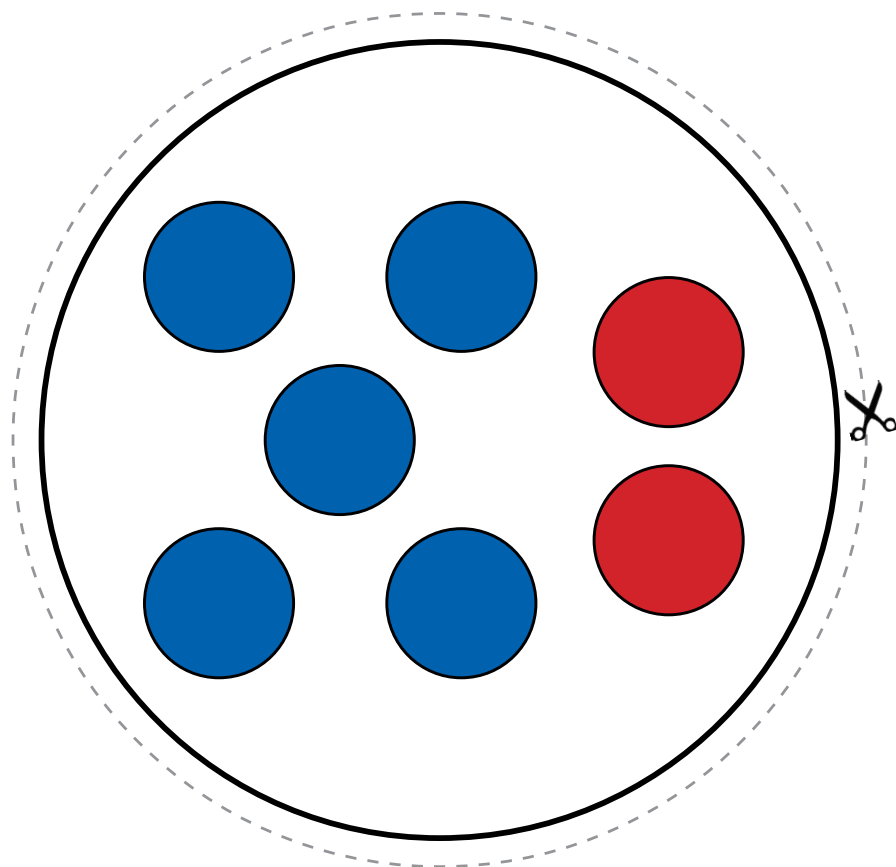
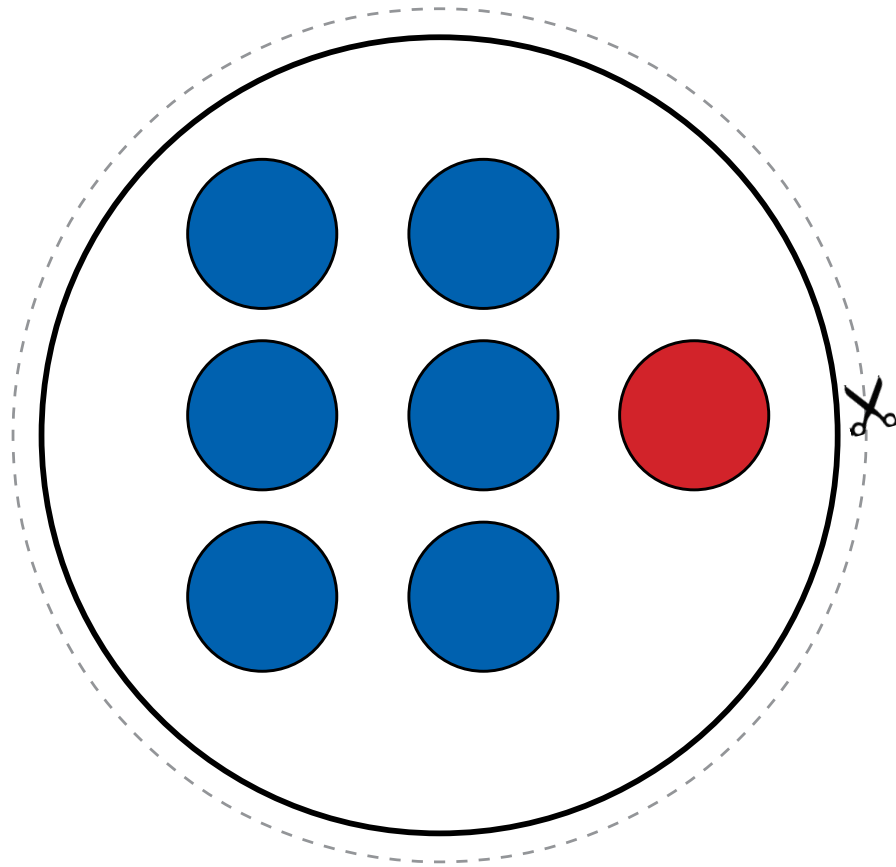

# Constellations de points familiers et non familiers (1 à 10)

## Format circulaire (suite)

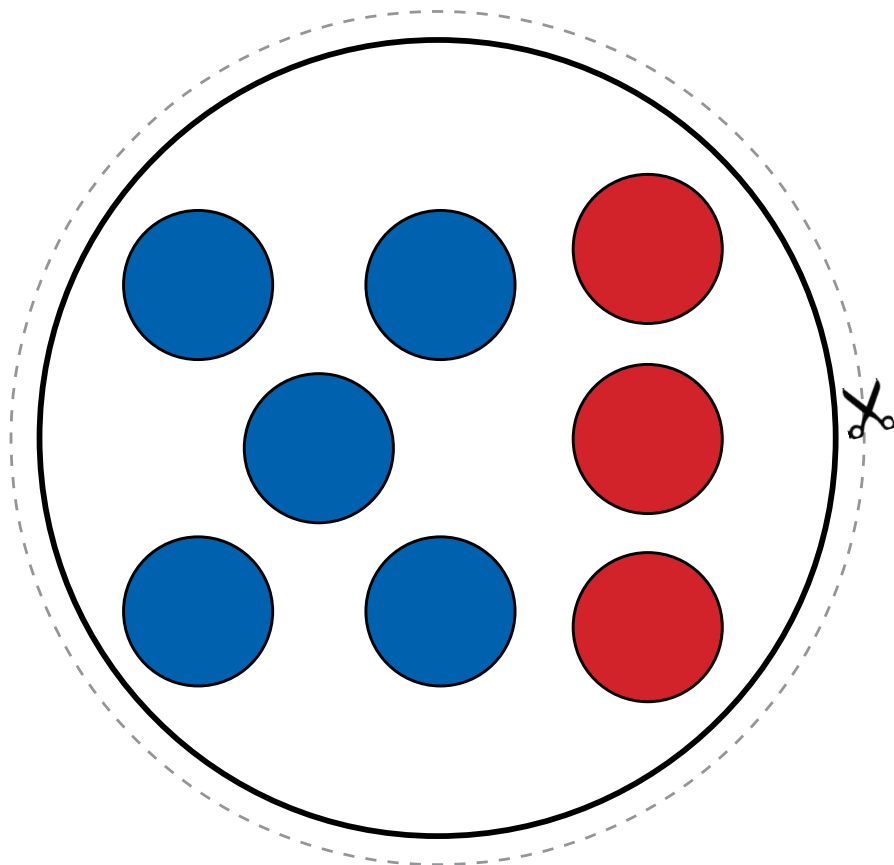
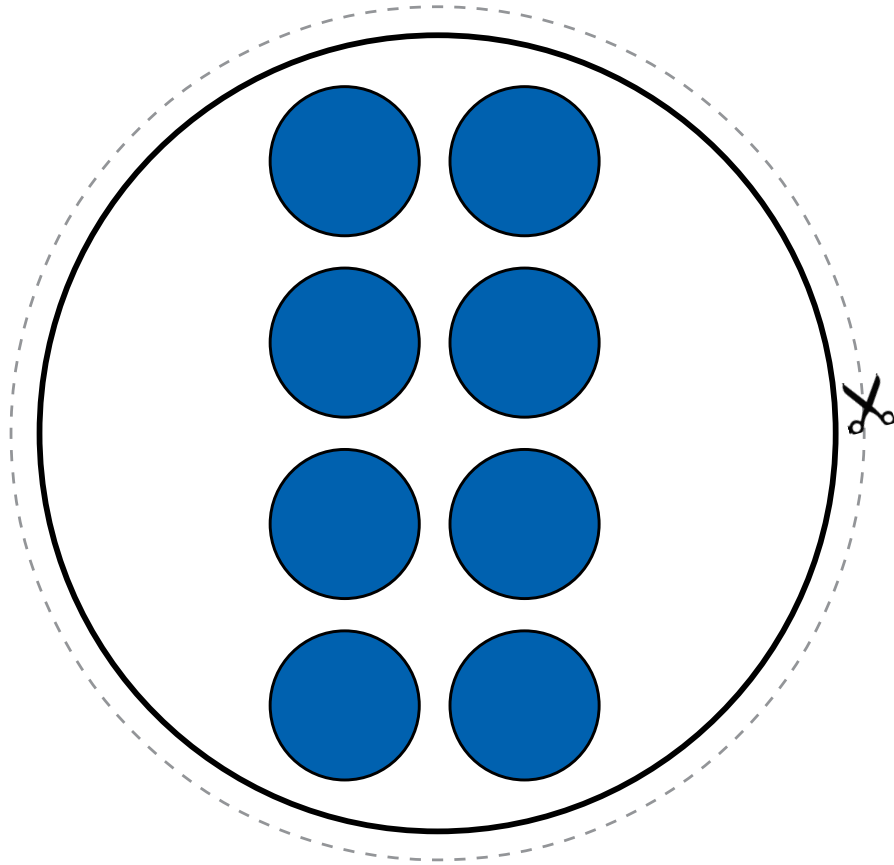

# Constellations de points familiers et non familiers (1 à 10)

## Format circulaire (suite)

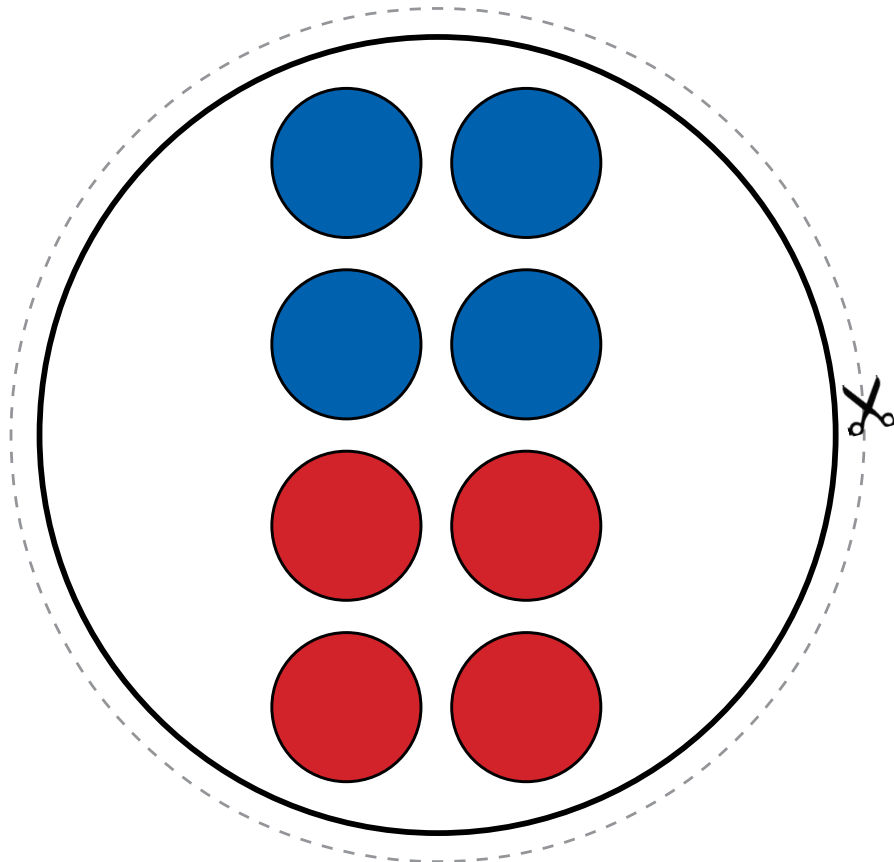
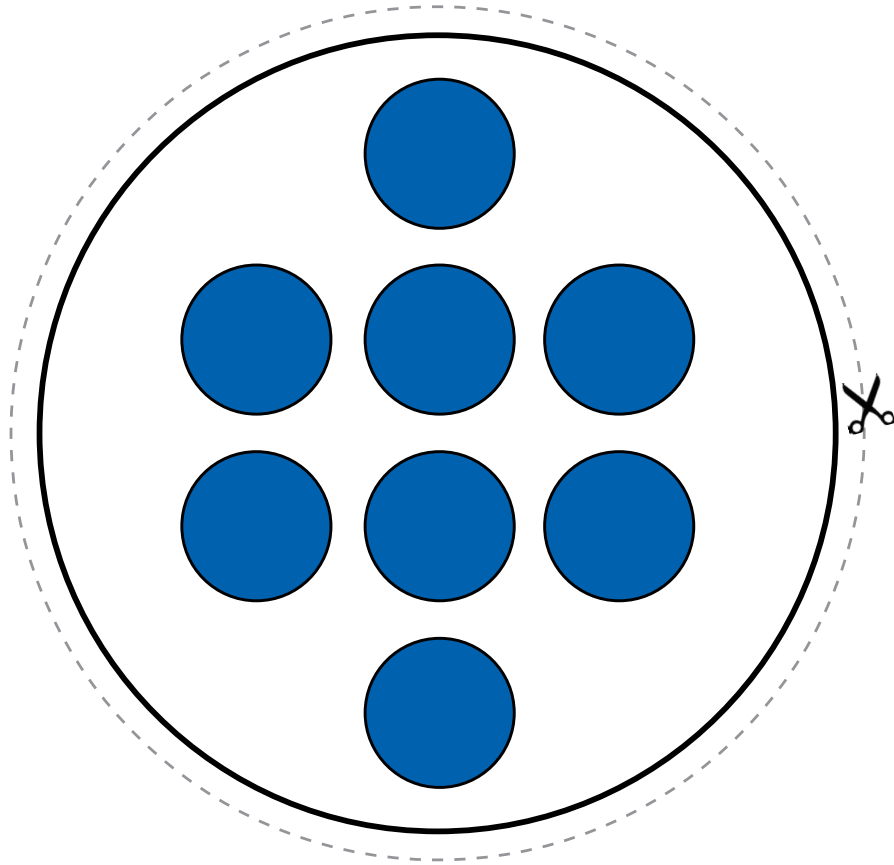

# Constellations de points familiers et non familiers (1 à 10)

## Format circulaire (suite)

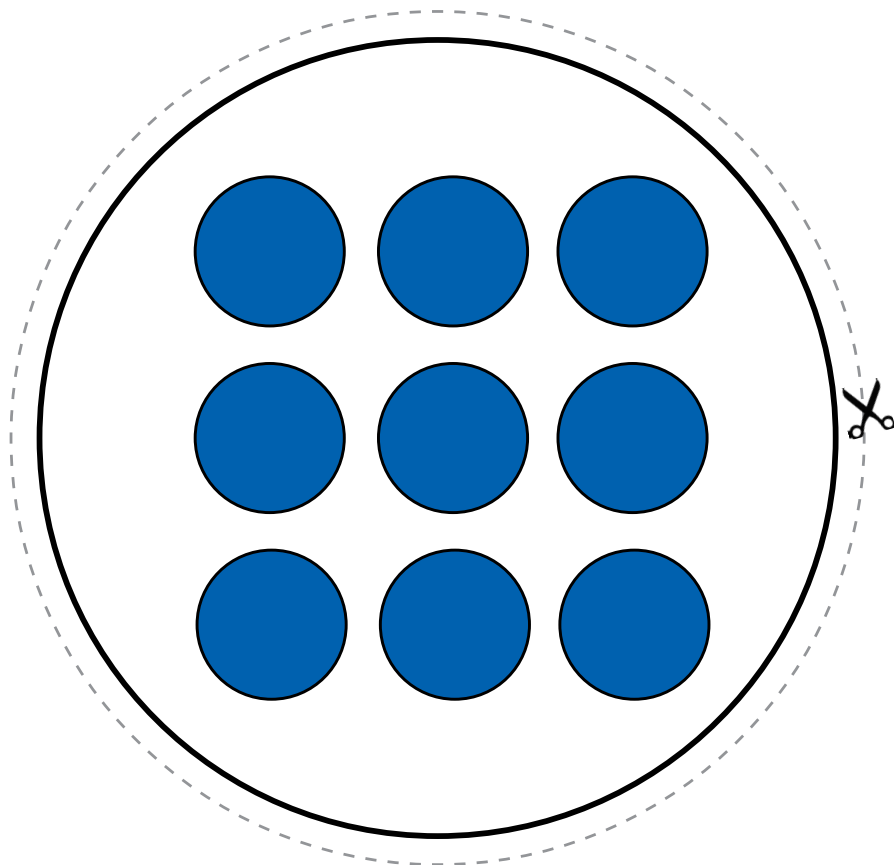
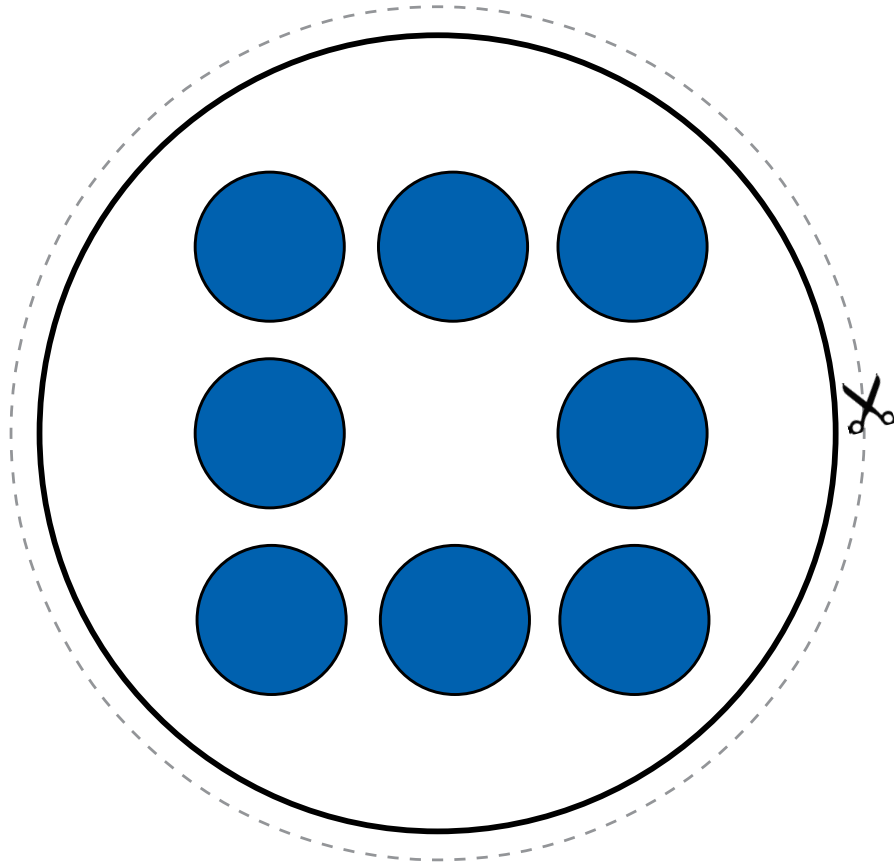

# Constellations de points familiers et non familiers (1 à 10)

## Format circulaire (suite)

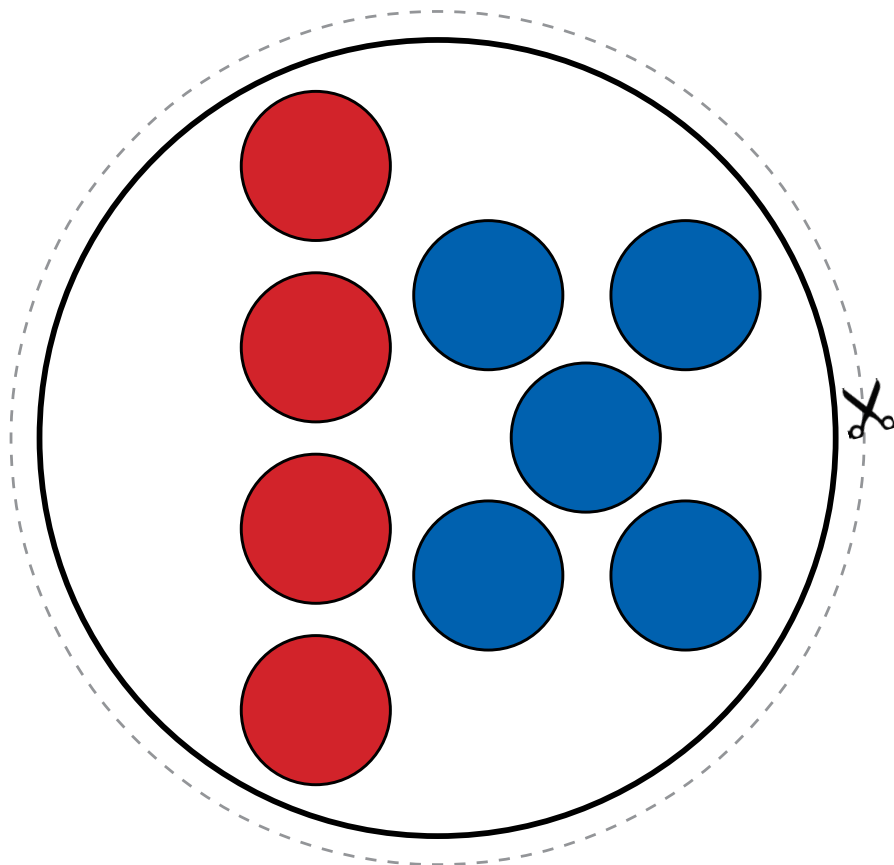
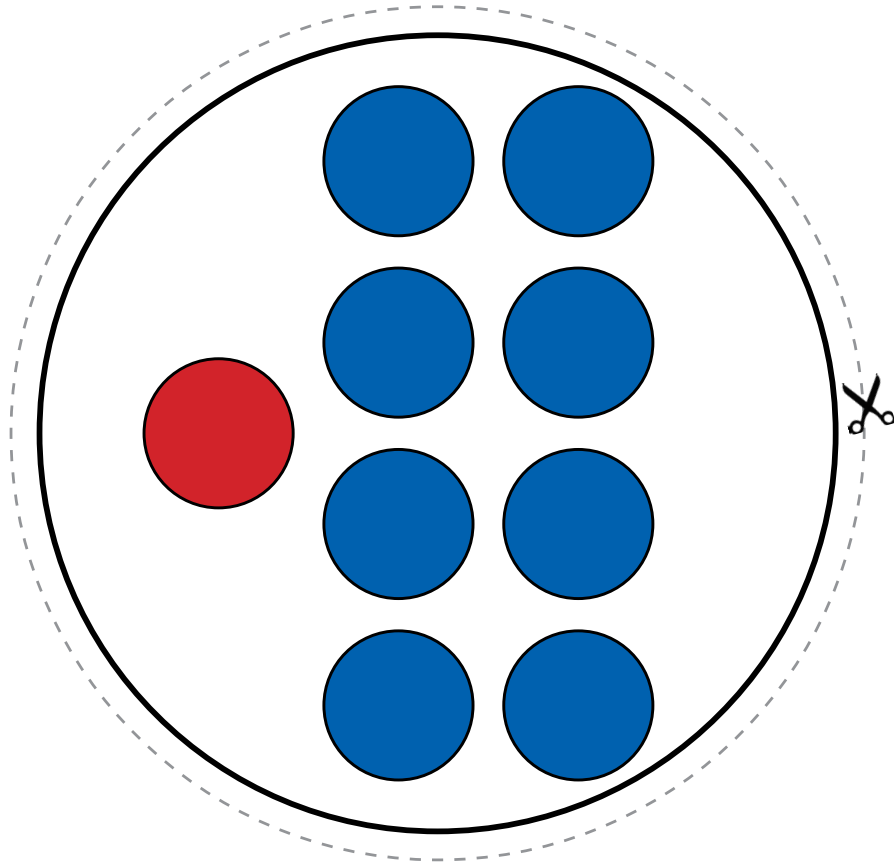

# Constellations de points familiers et non familiers (1 à 10)

## Format circulaire (suite)

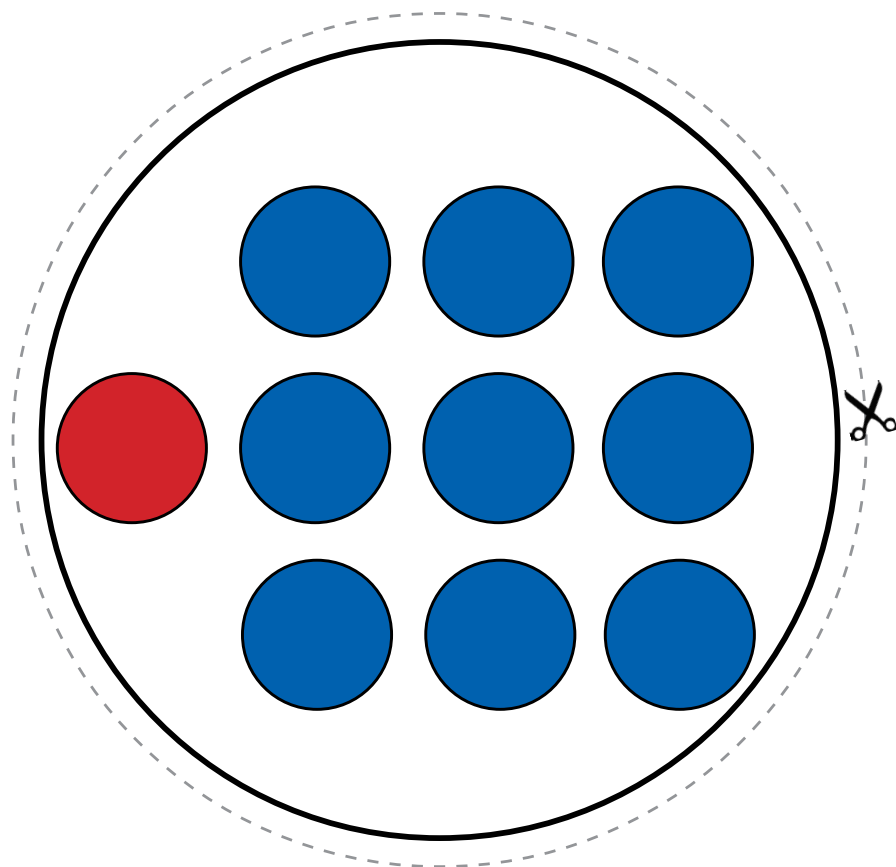
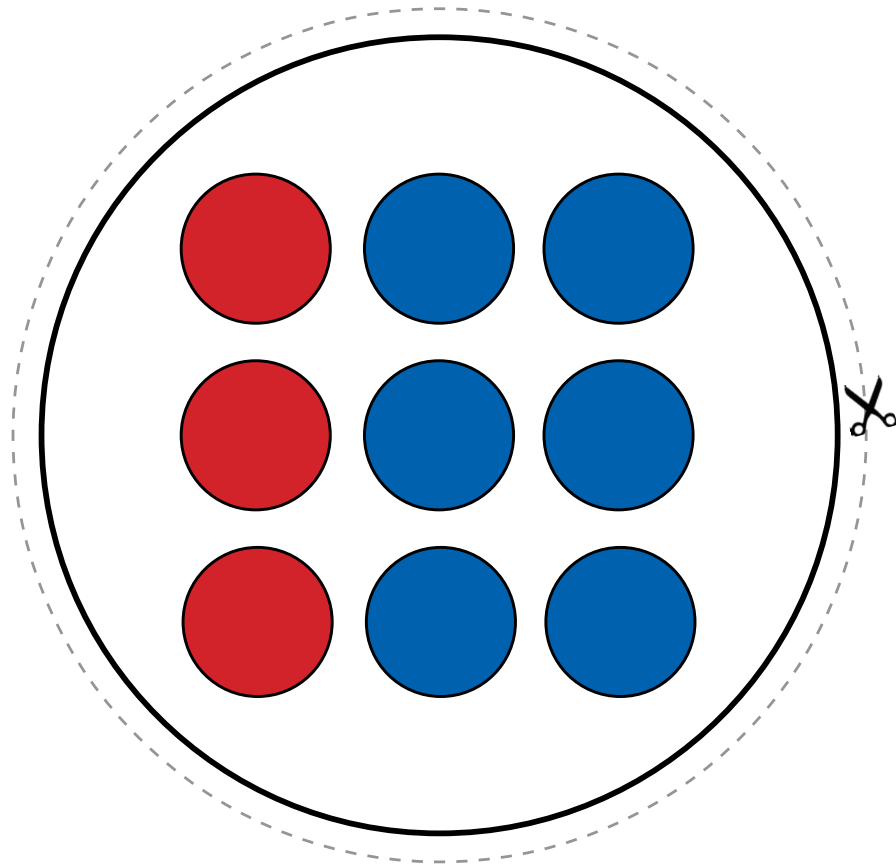

# Constellations de points familiers et non familiers (1 à 10)

## Format circulaire (suite)

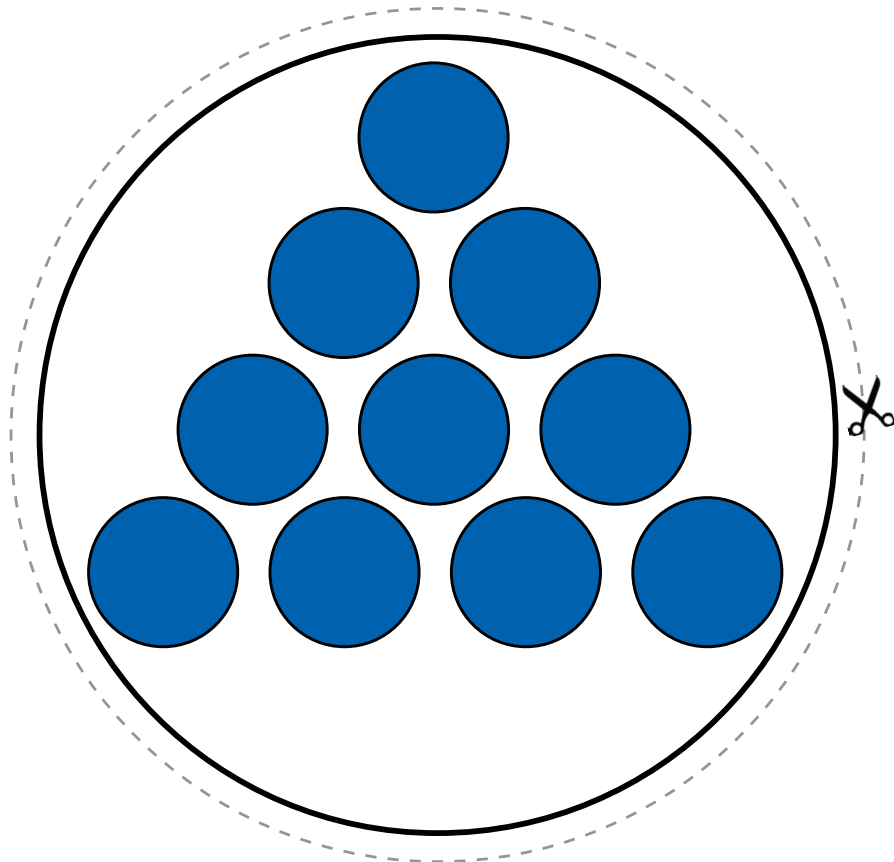
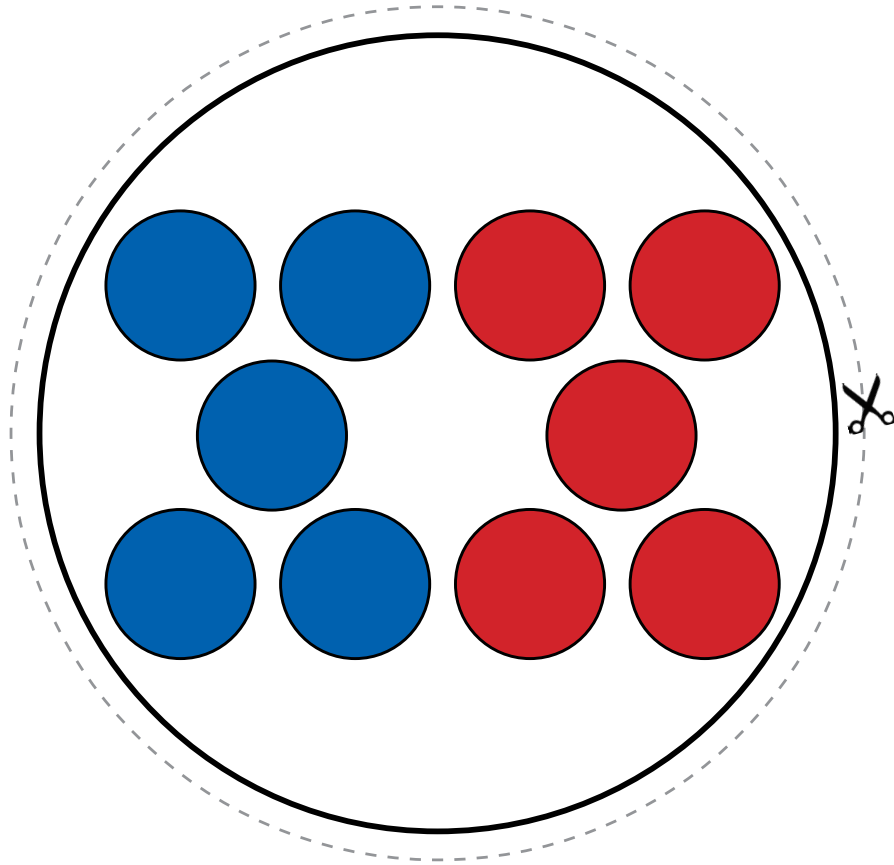

# Constellations de points familiers (1 à 6)

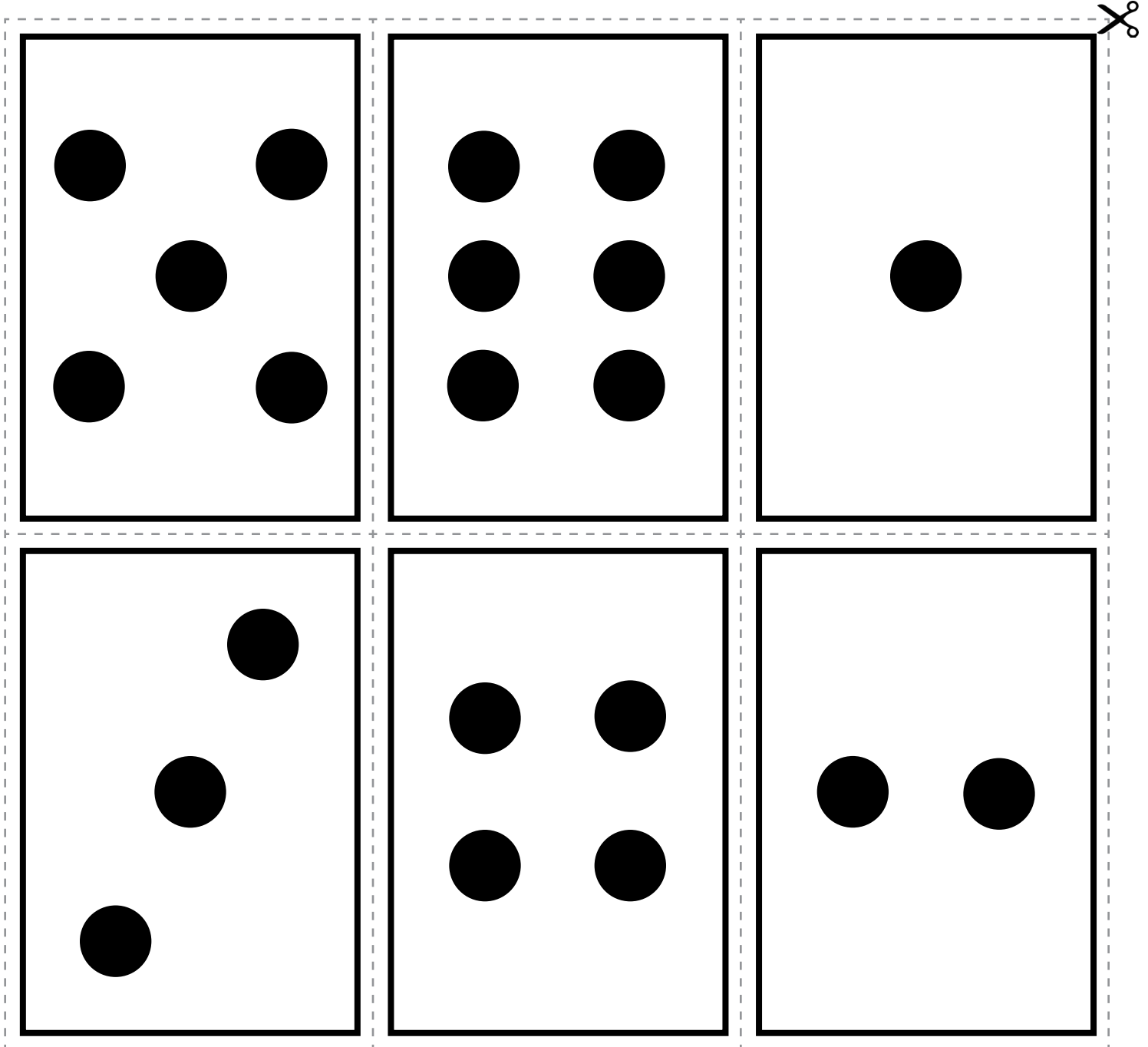



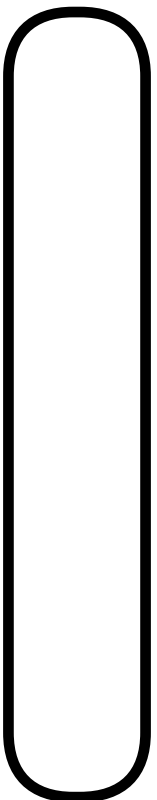

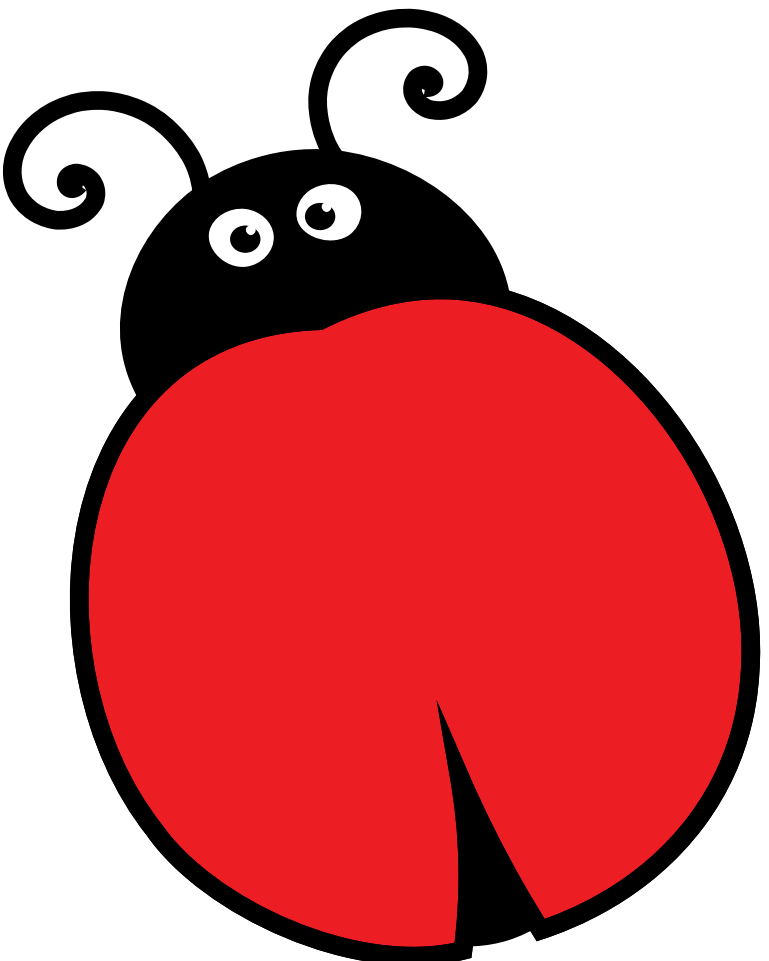
un



deux

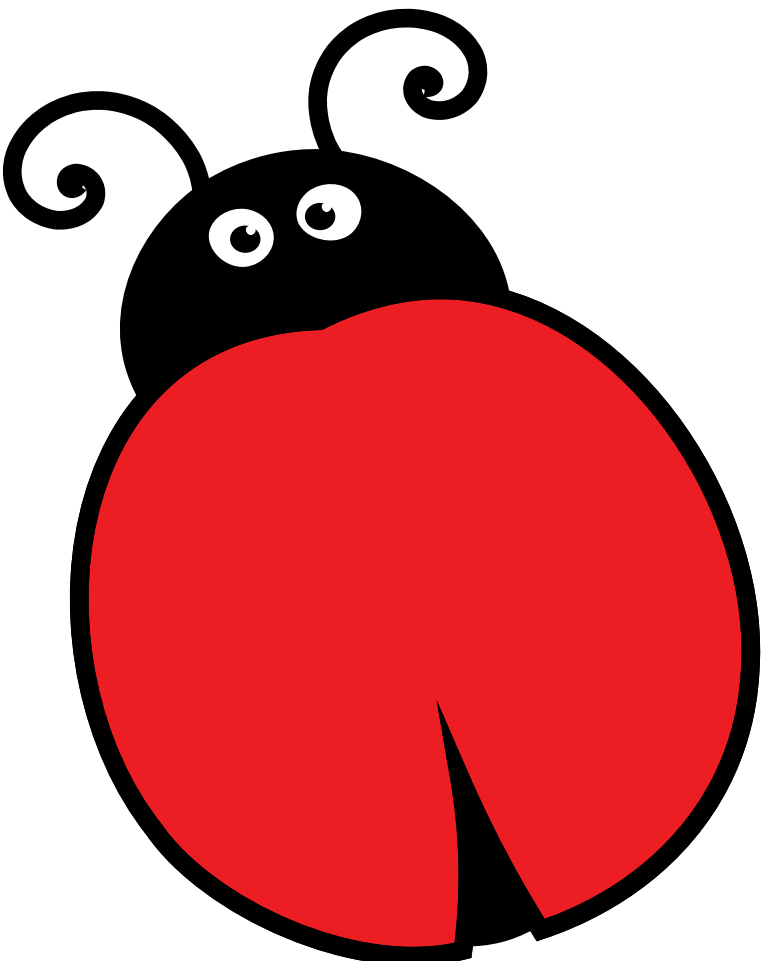

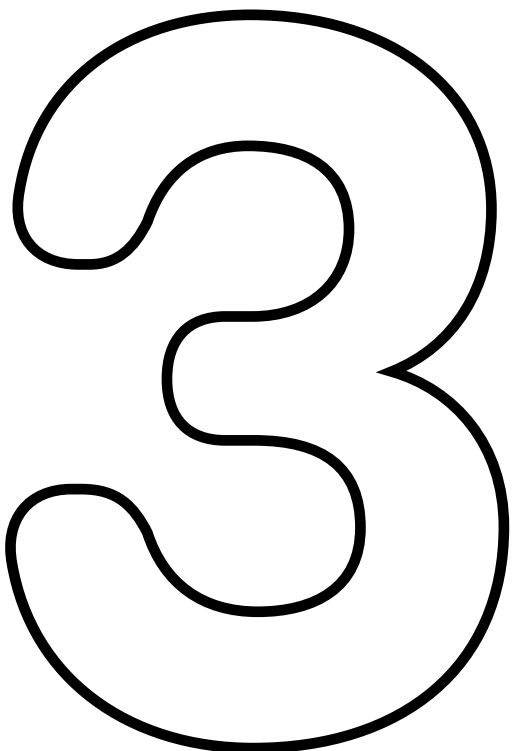

**trois**

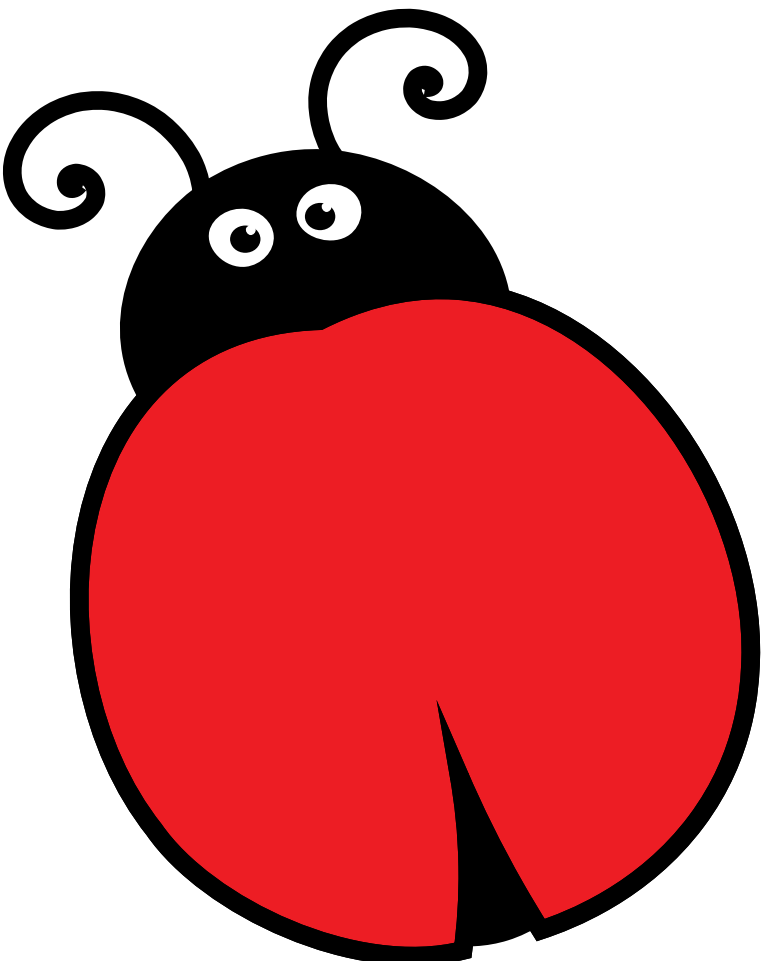



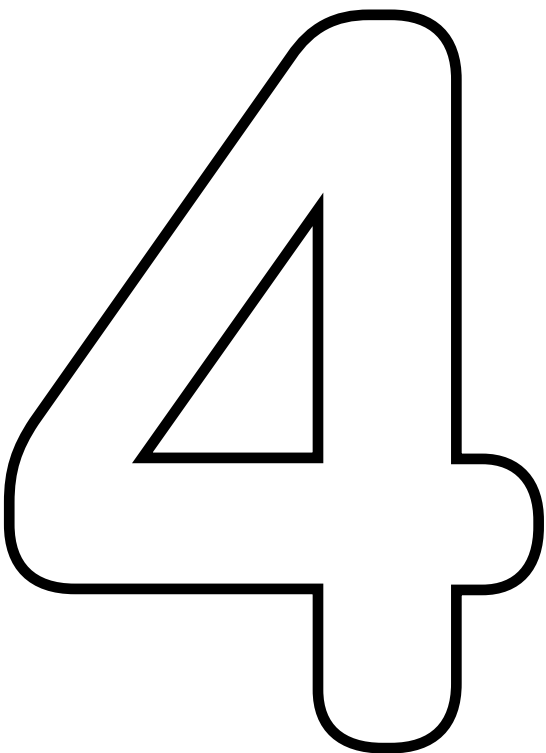

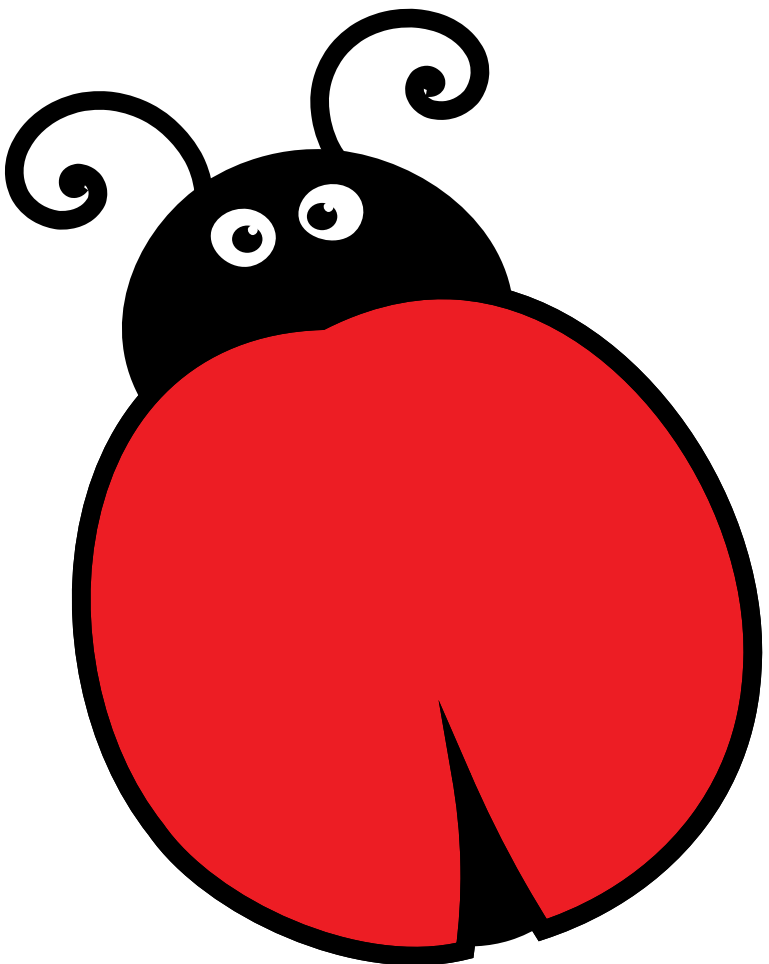
A 2x5 grid of empty rectangular boxes, intended for representing the number 4 using concrete objects or symbols.

quatre

The word "quatre" is written in a large, bold, black sans-serif font, centered below the ladybug illustration.

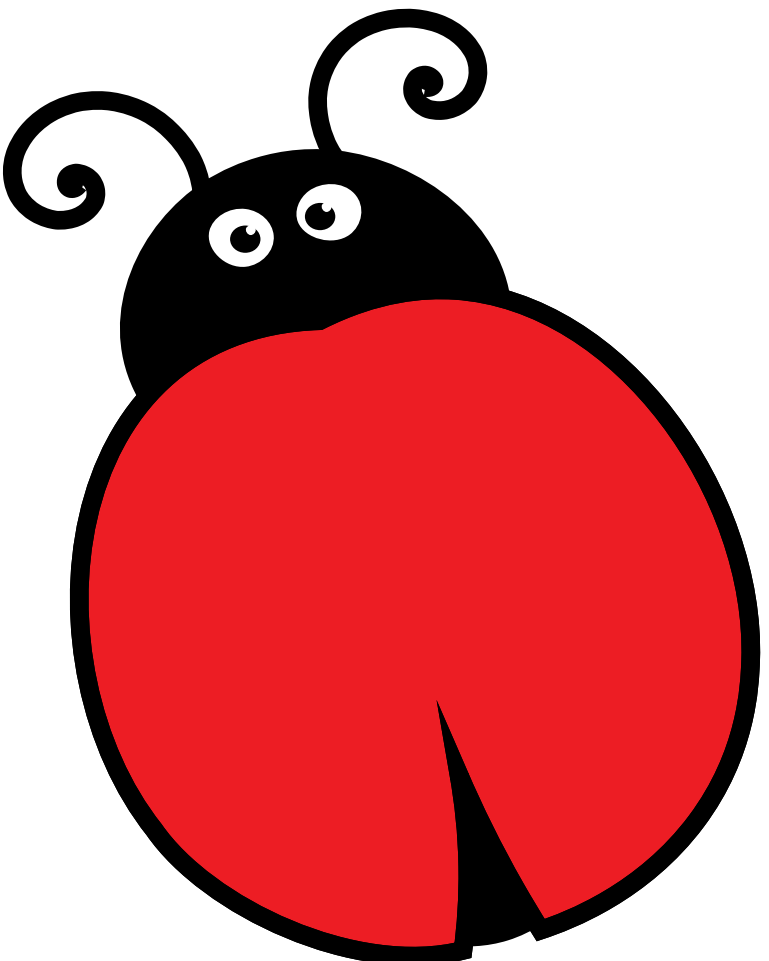

**cinq**



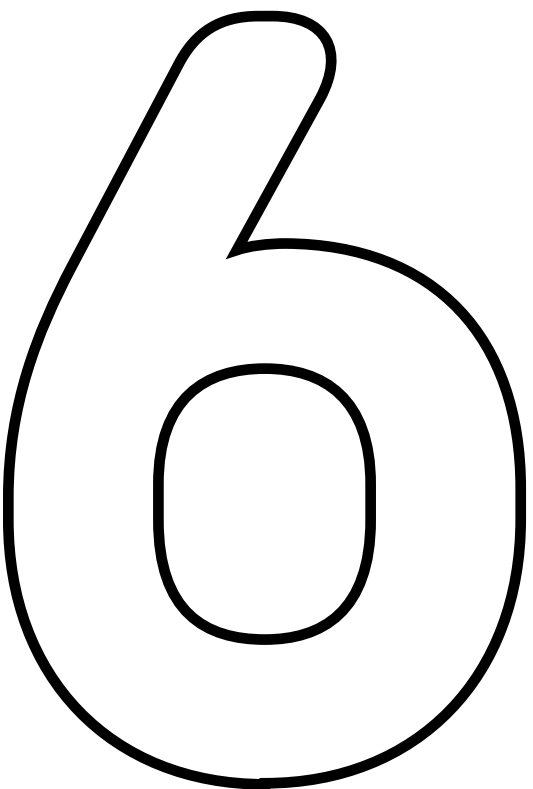

six

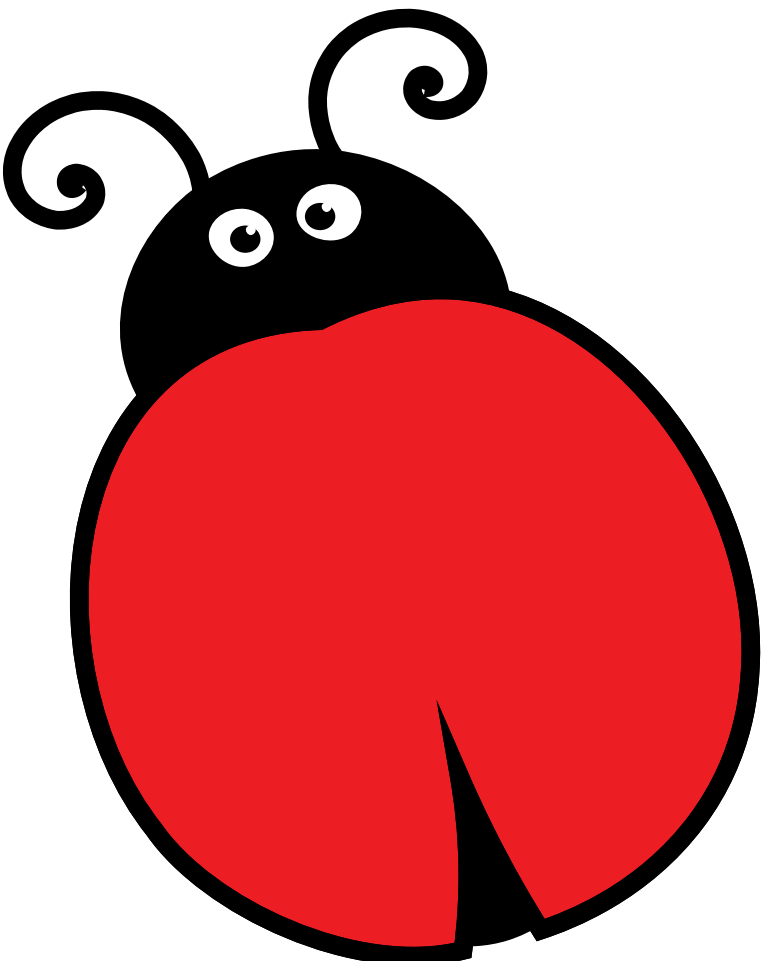

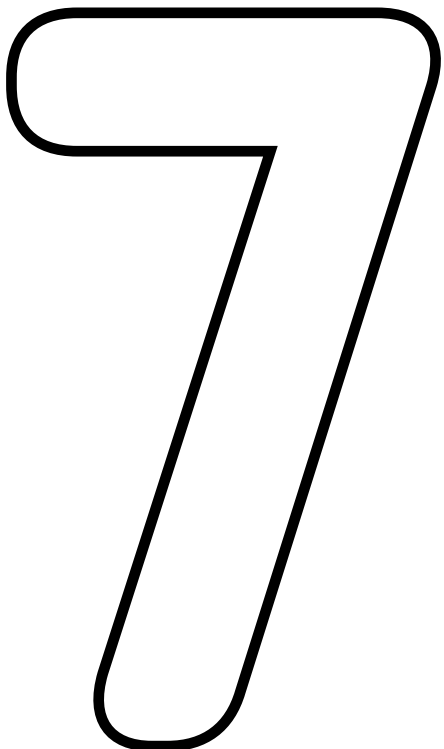

sept

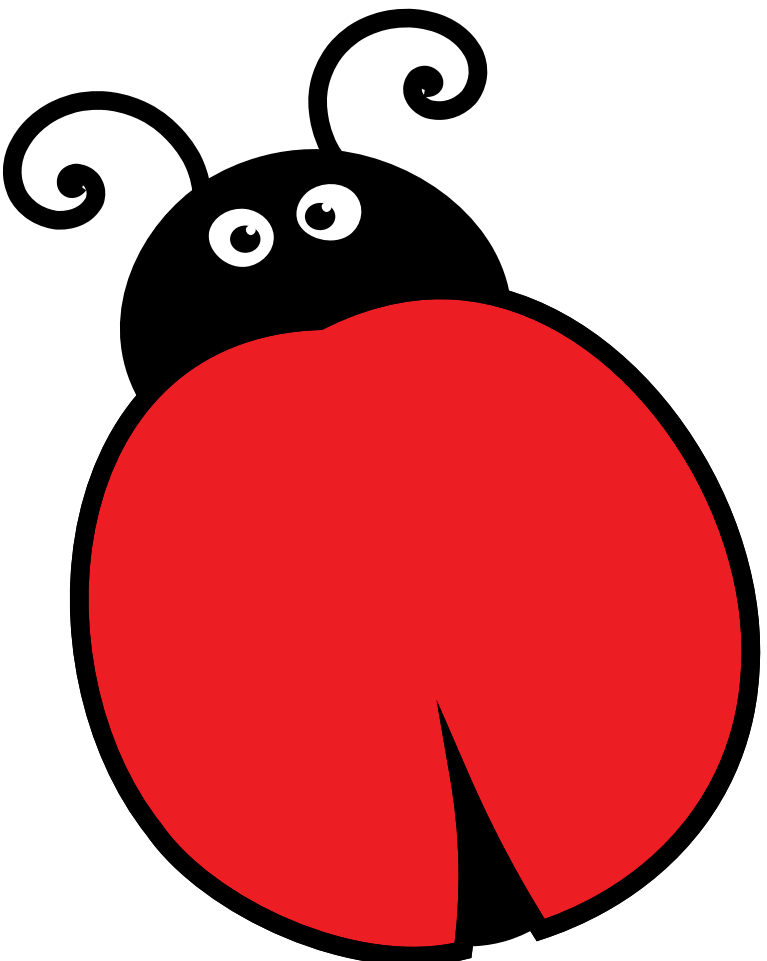



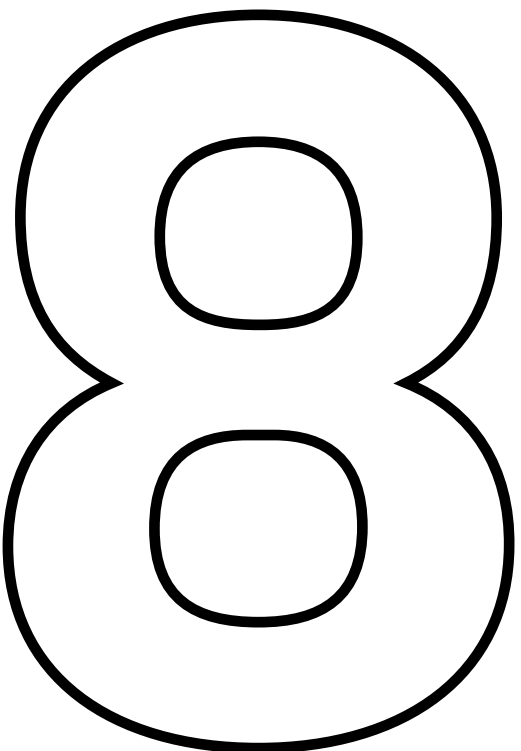

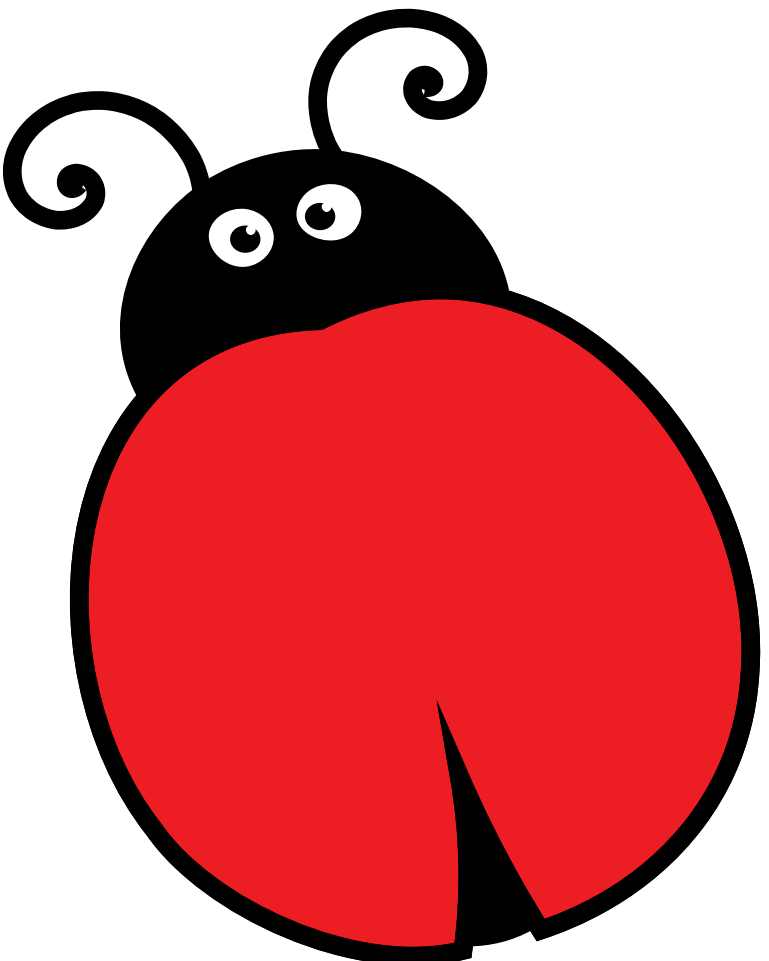

**huit**



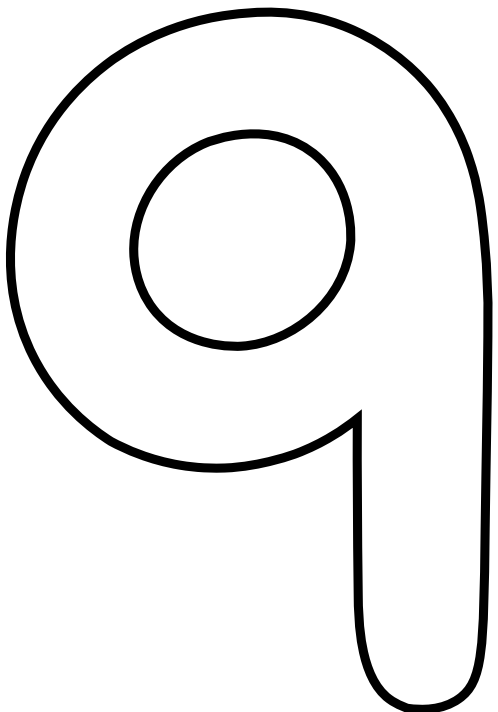

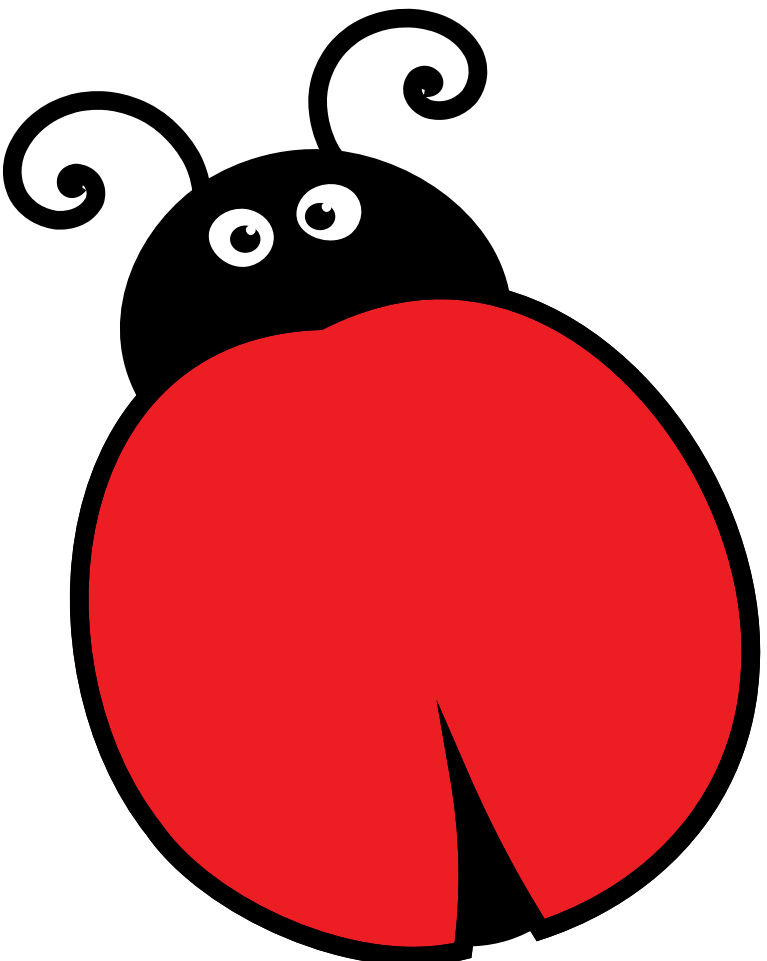

neuf



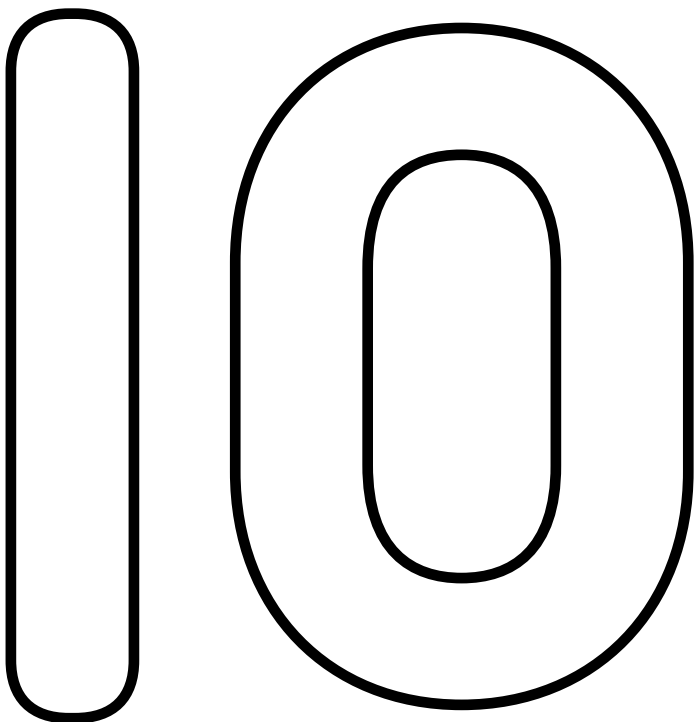

**dix**

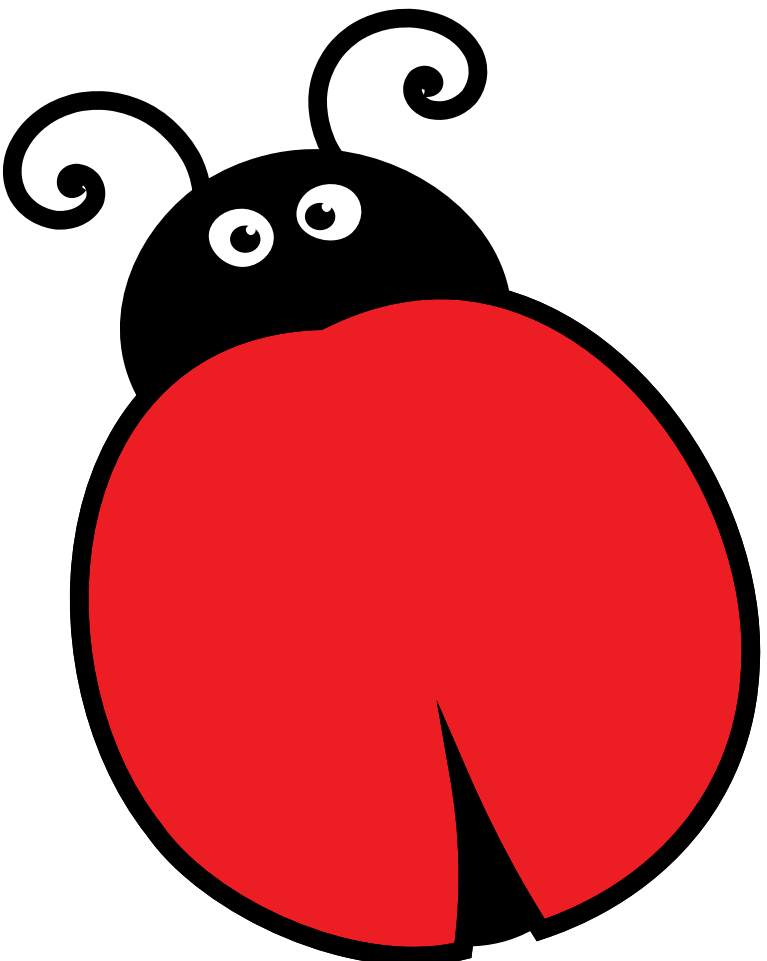

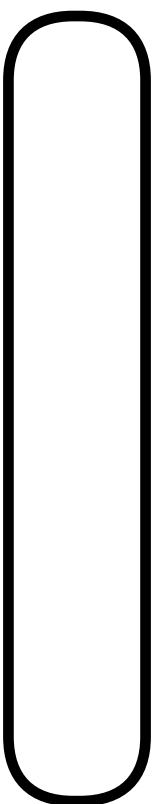

**un**

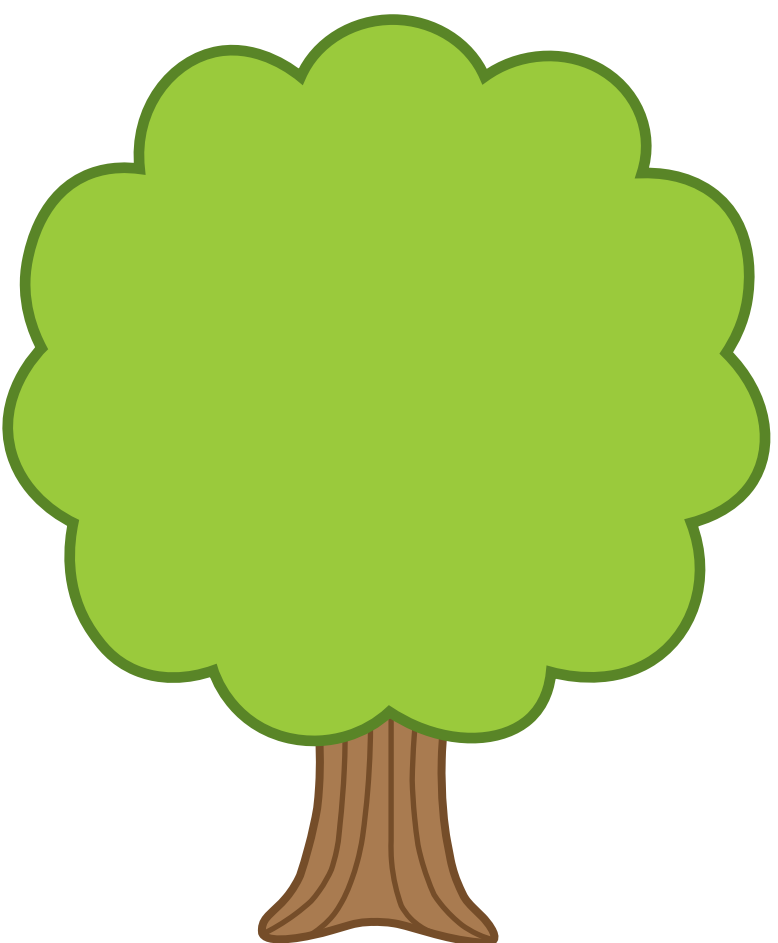



deux

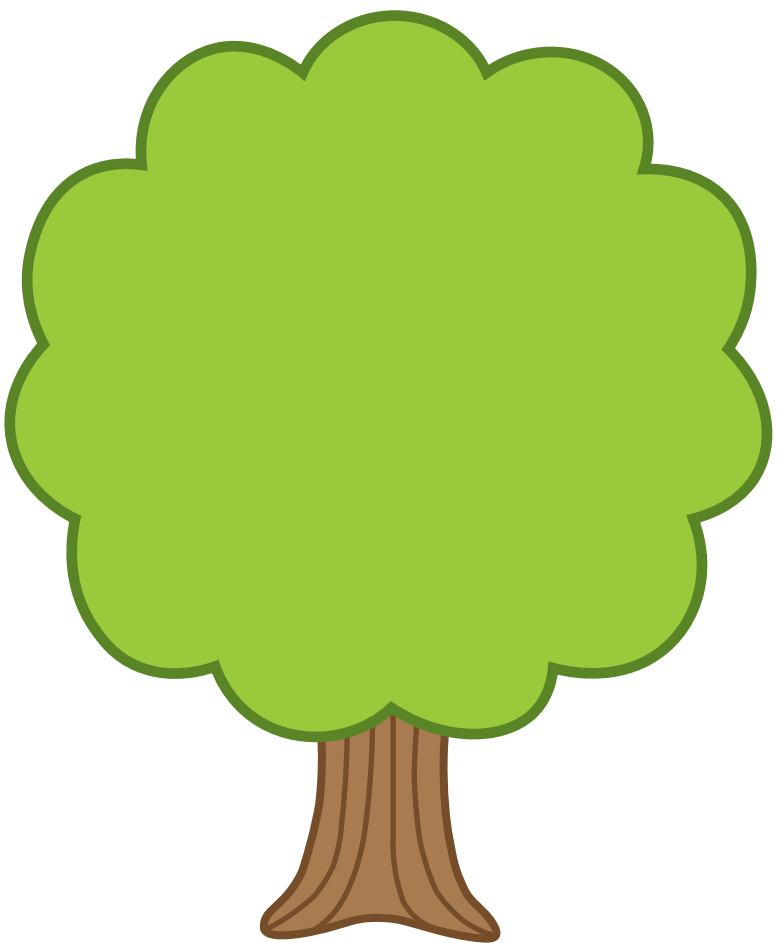

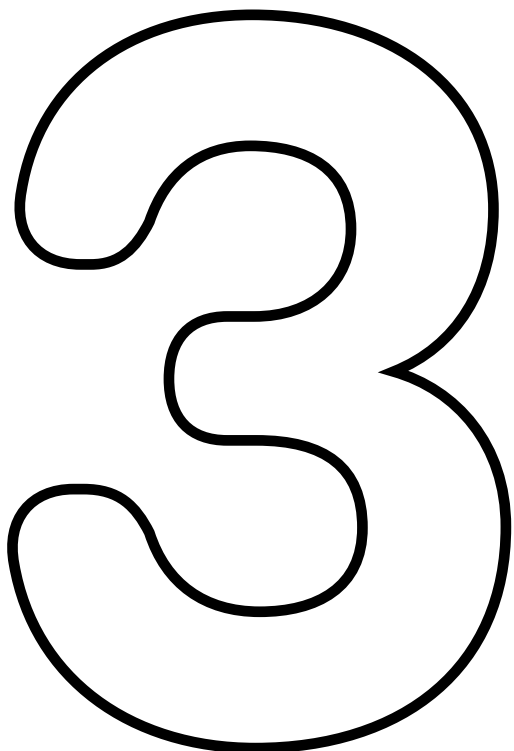

**trois**

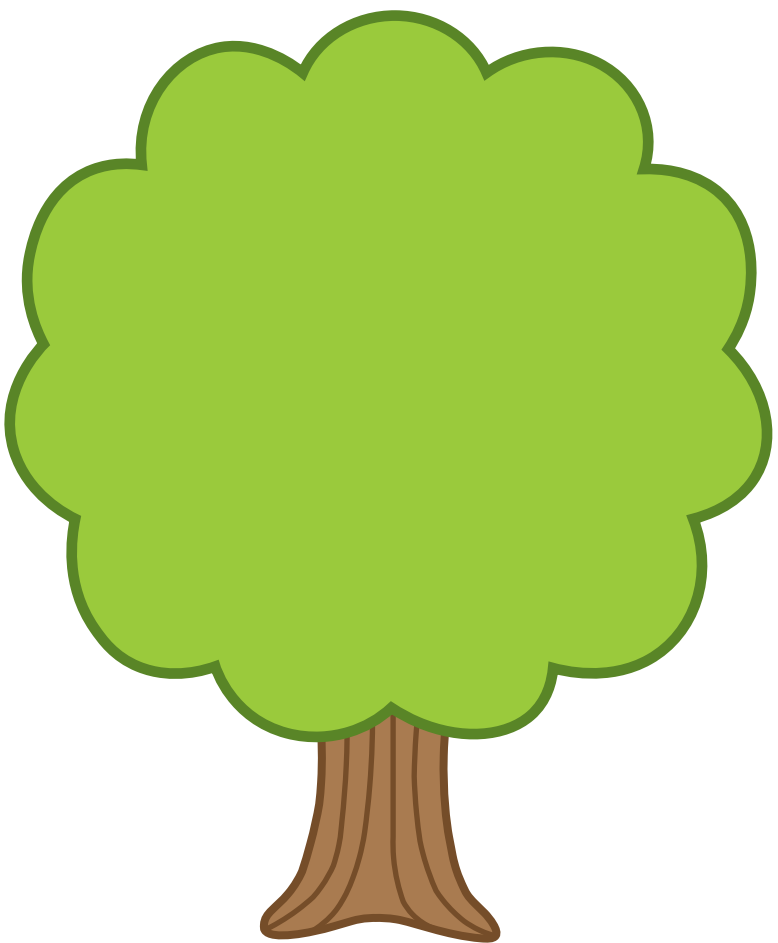

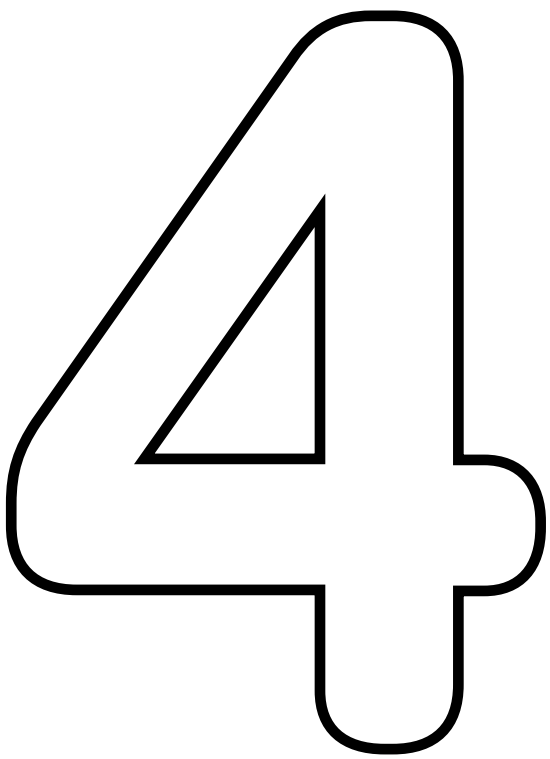

**quatre**

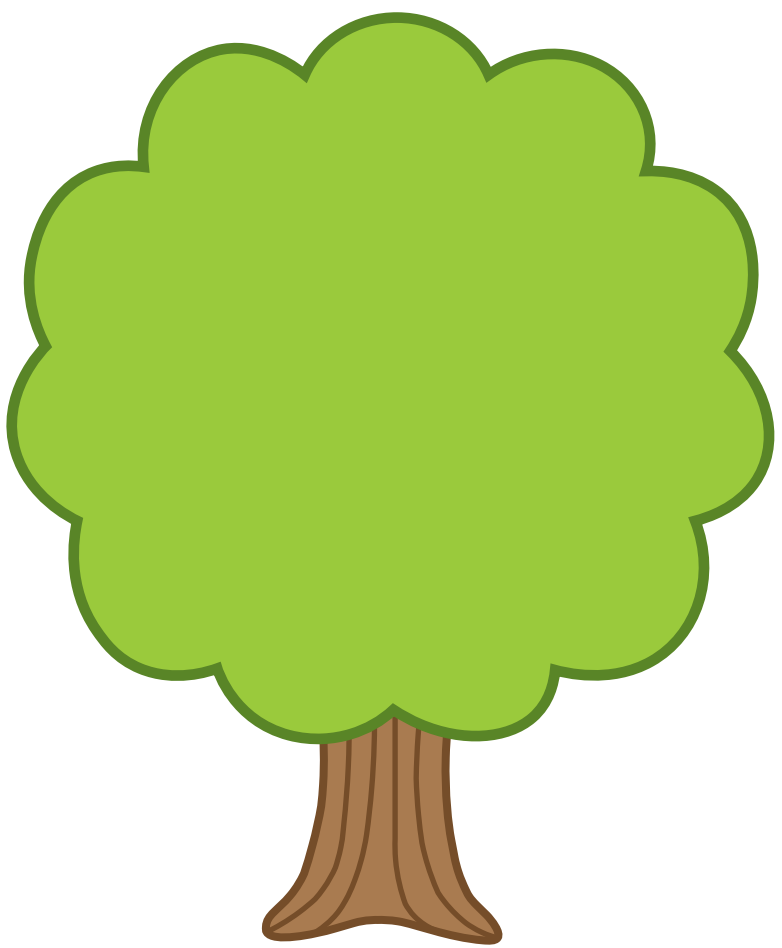



**cinq**

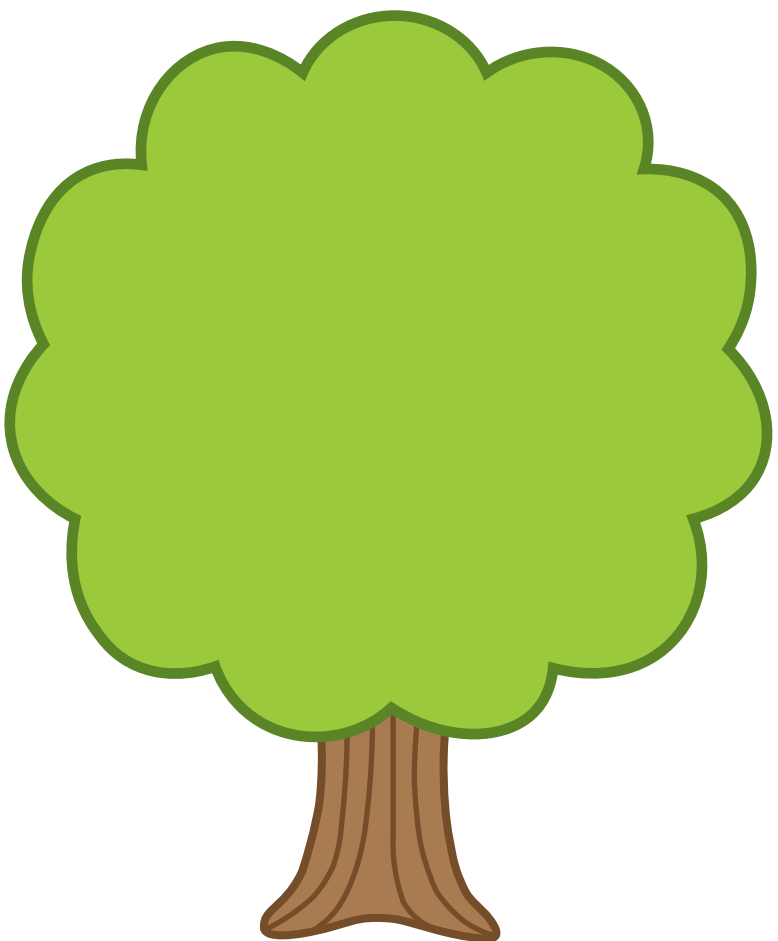





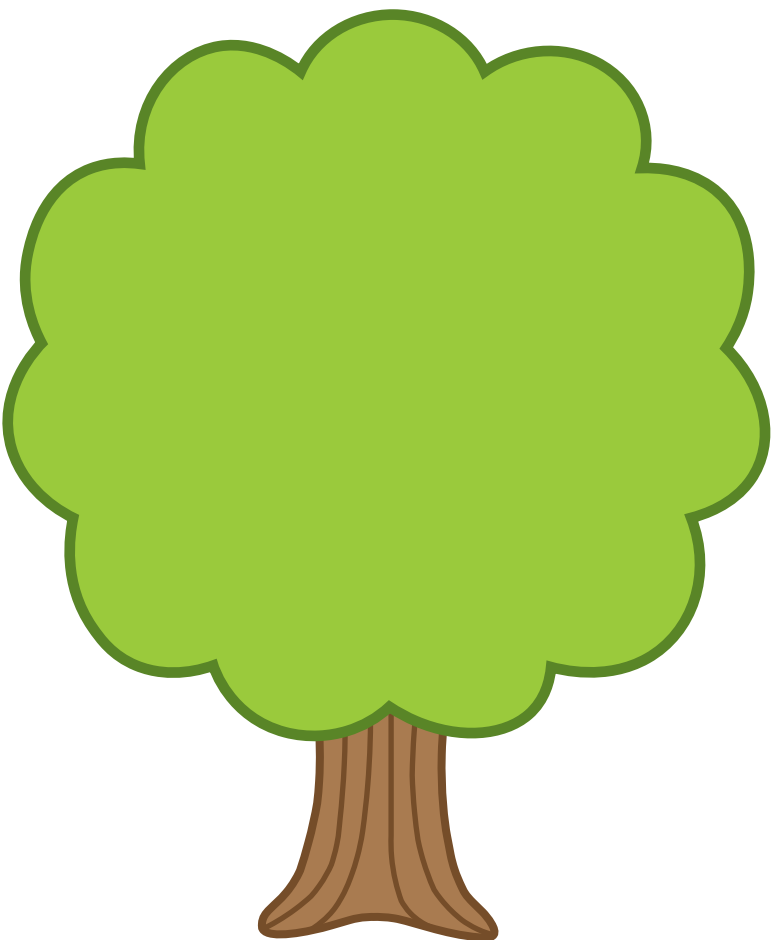

**six**



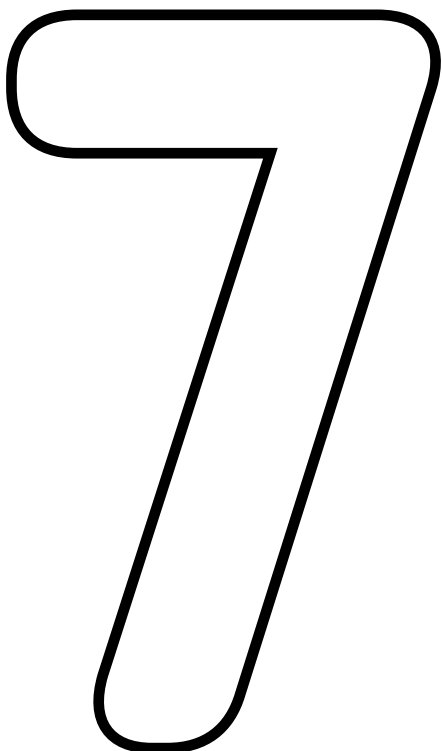

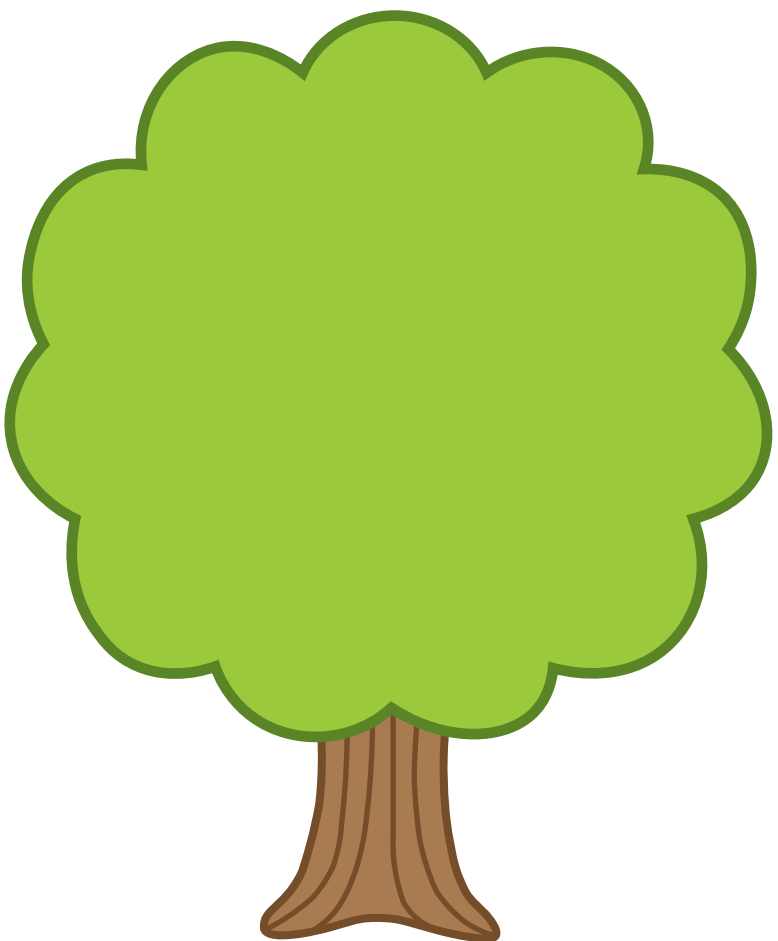

**sept**



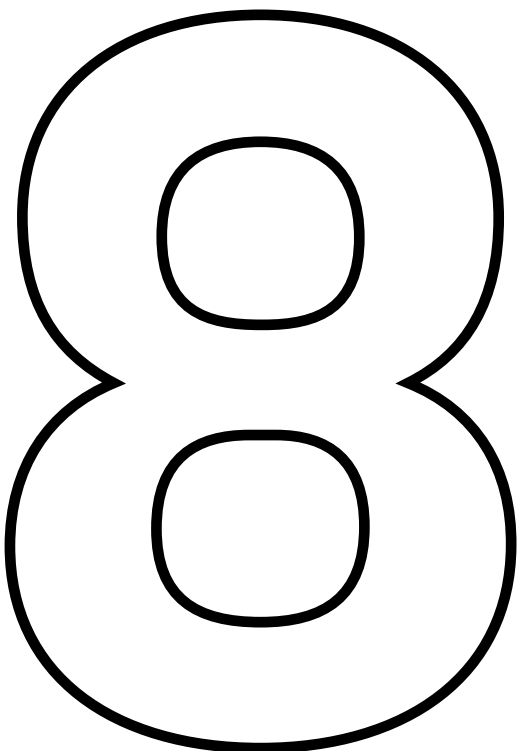

**huit**

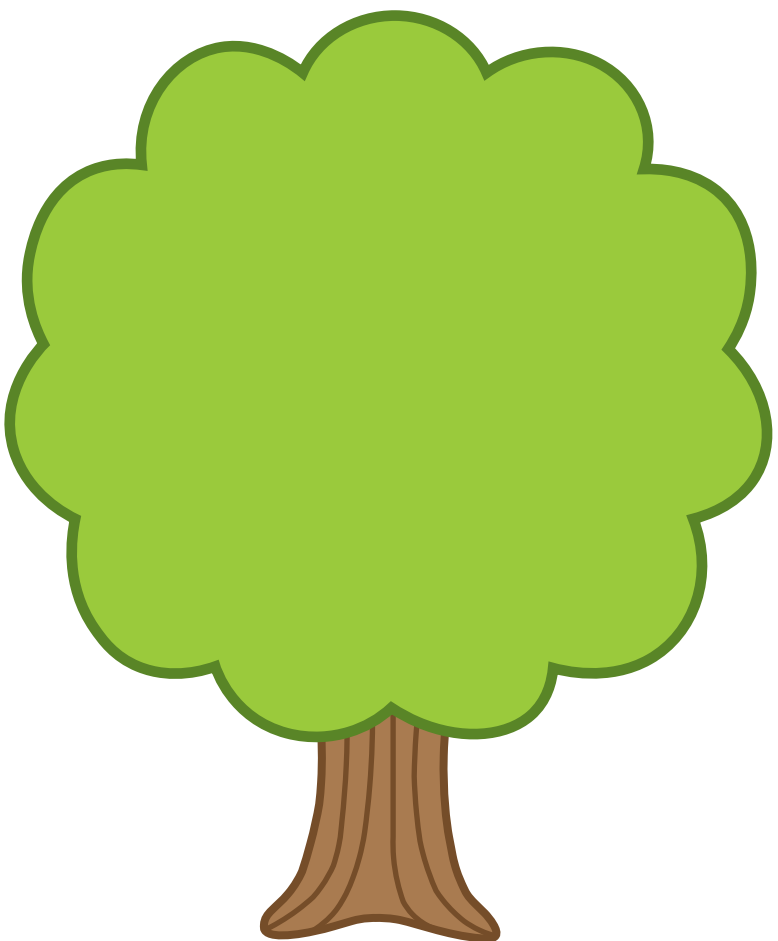

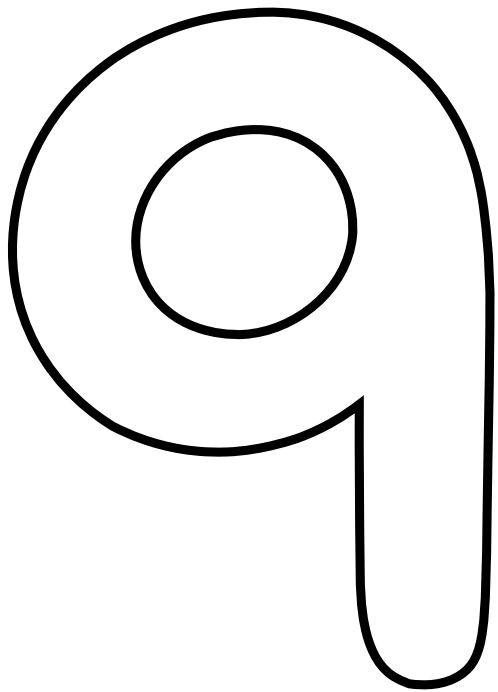

**neuf**

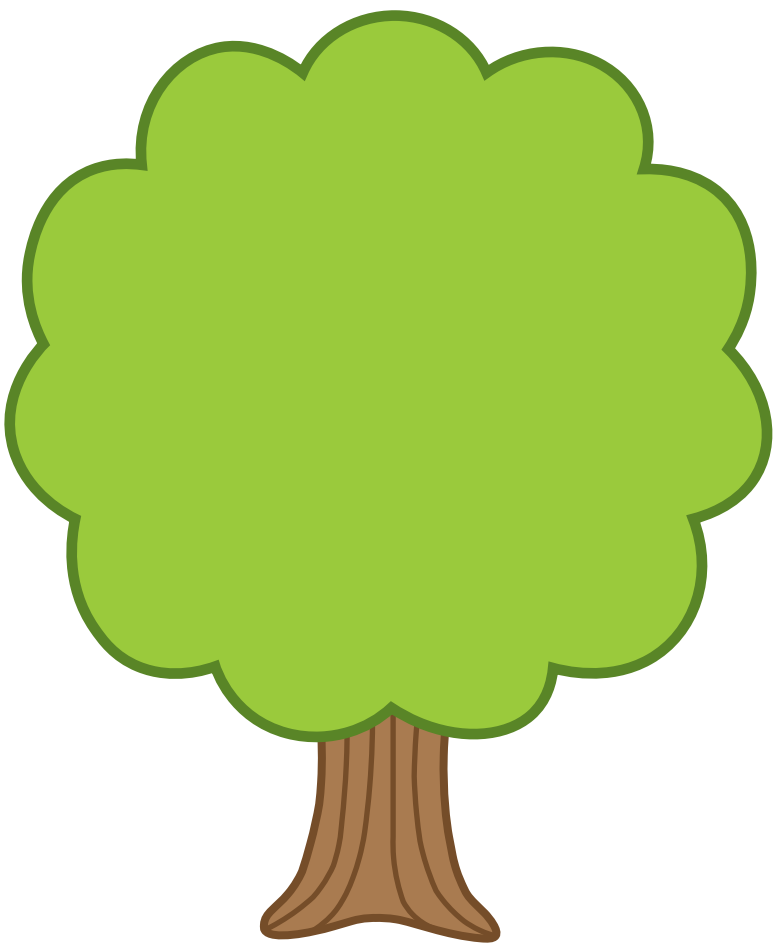

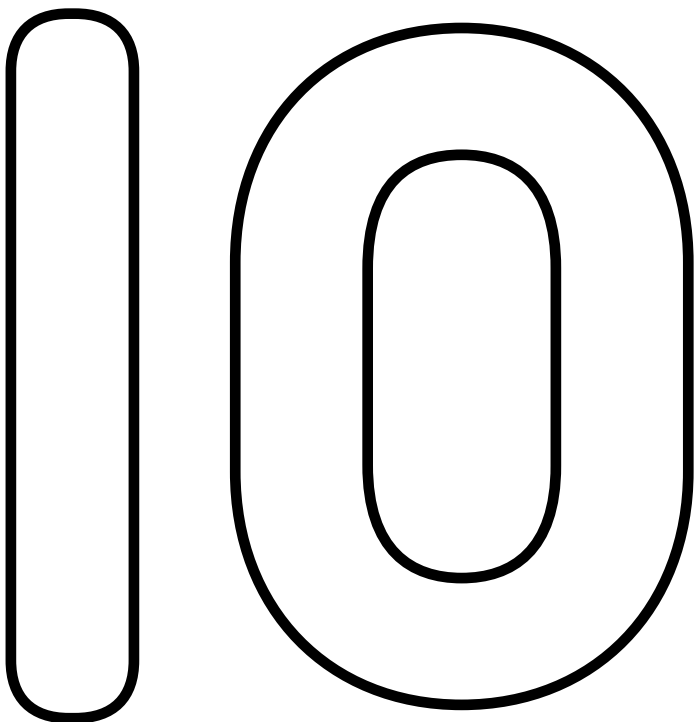

**dix**

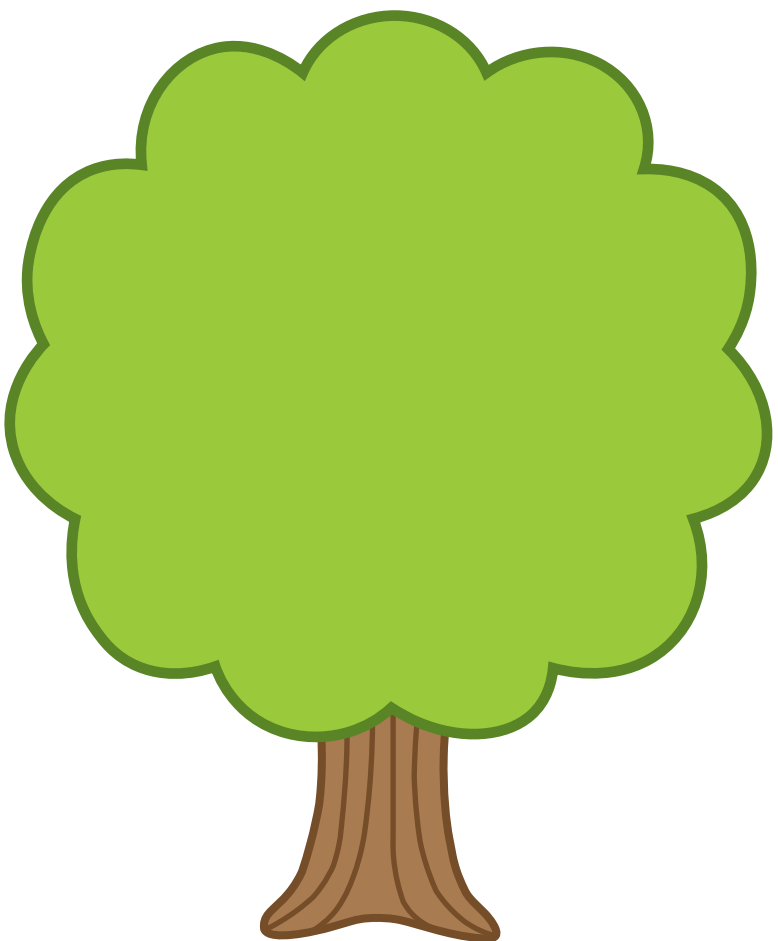

# Cartes de représentations imagée et symbolique des nombres - Appariements (1 à 10)

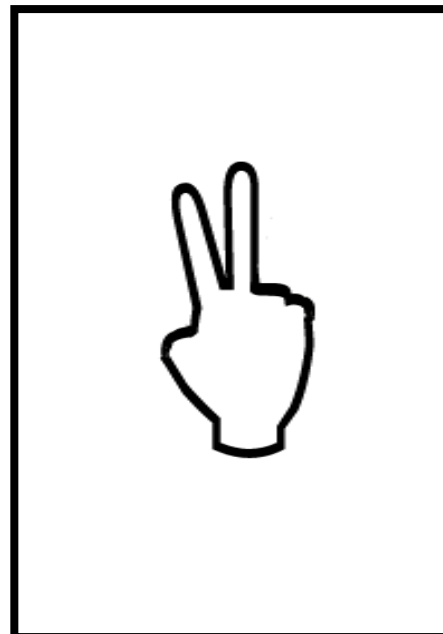
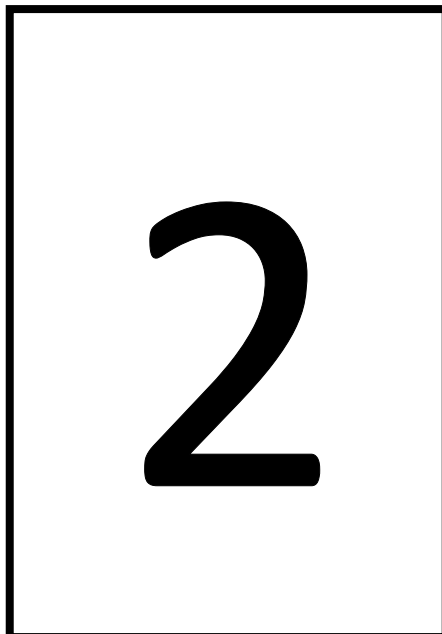
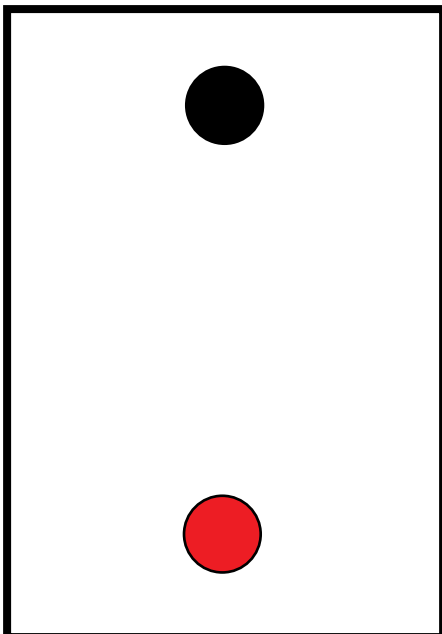
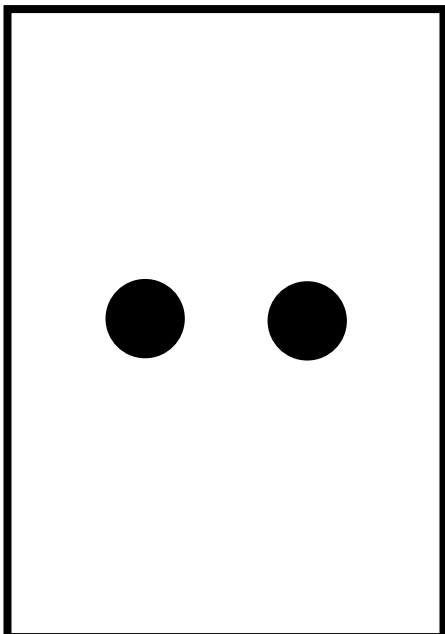
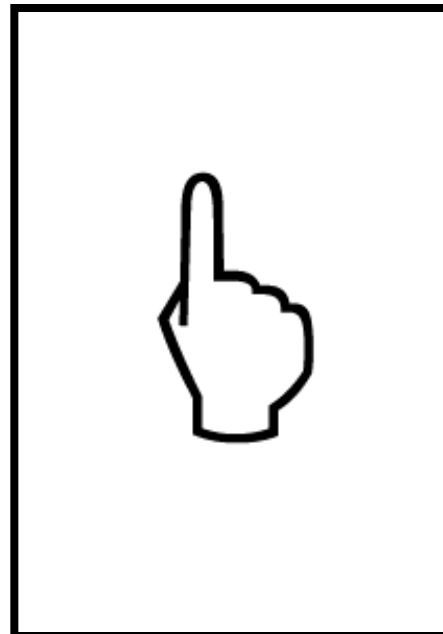
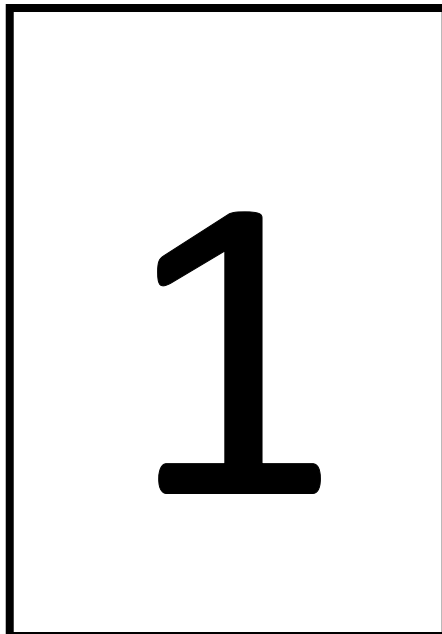
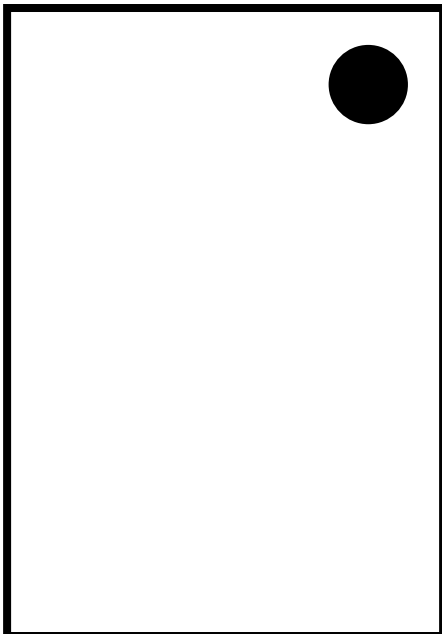
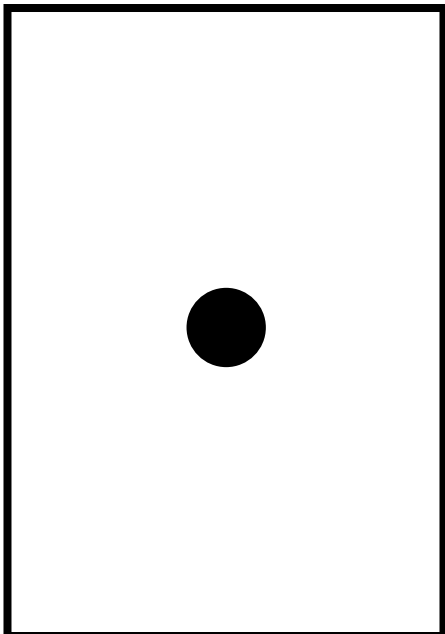

# Cartes de représentations imagée et symbolique des nombres - Appariements (1 à 10) (suite)

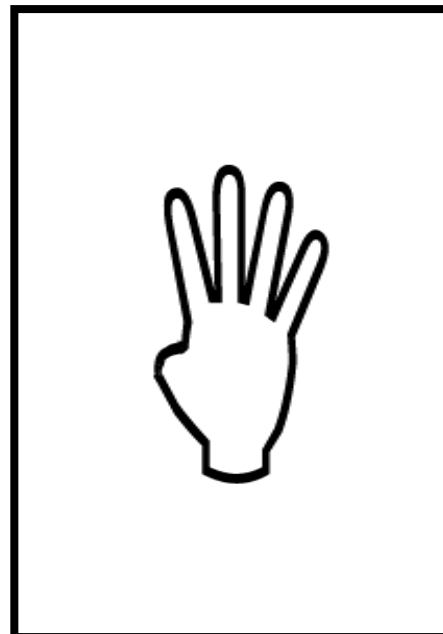
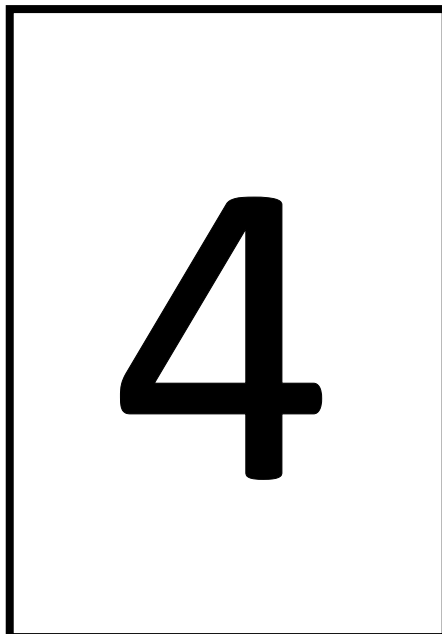
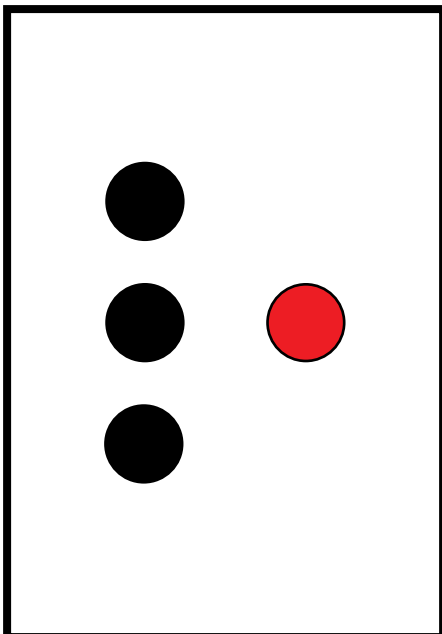
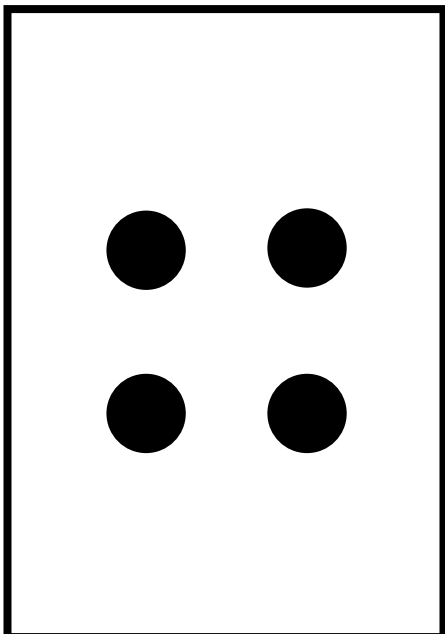
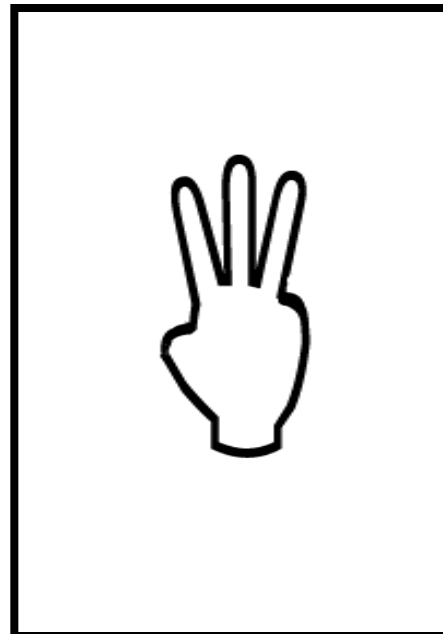
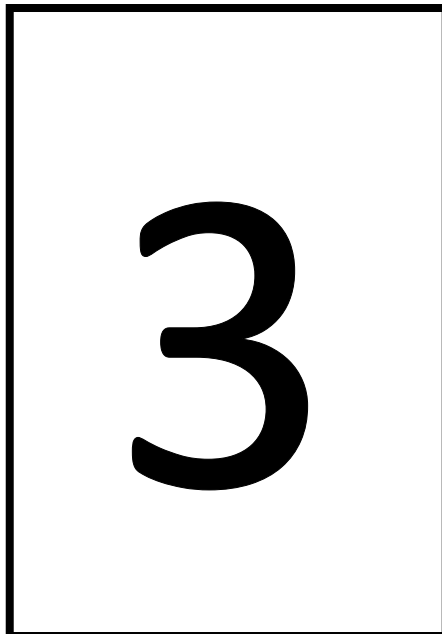
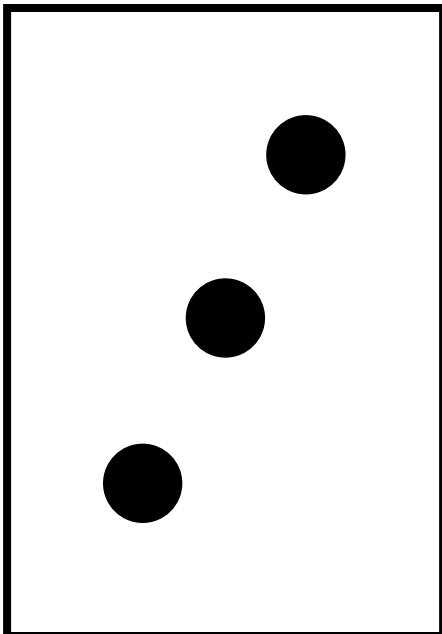
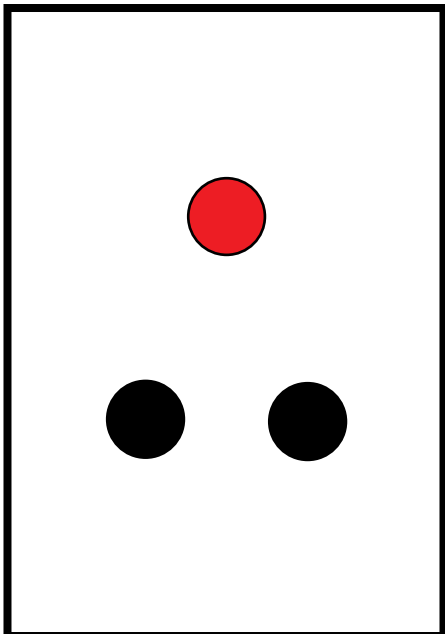

# Cartes de représentations imagée et symbolique des nombres - Appariements (1 à 10) (suite)

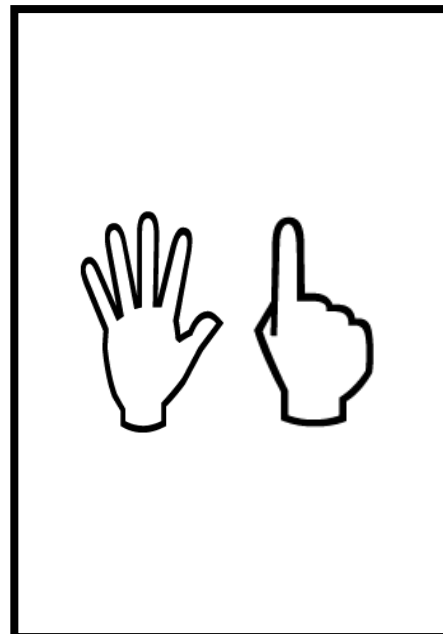
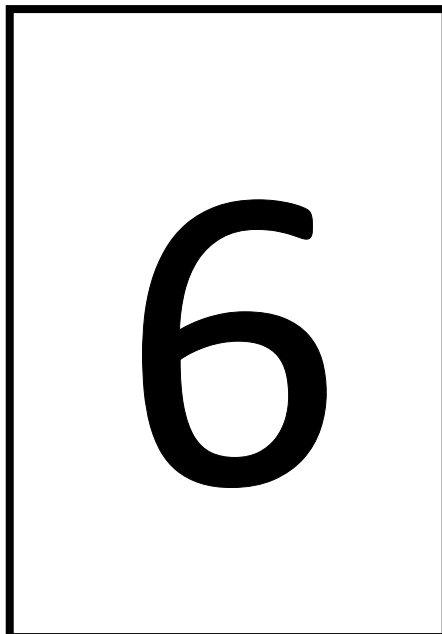
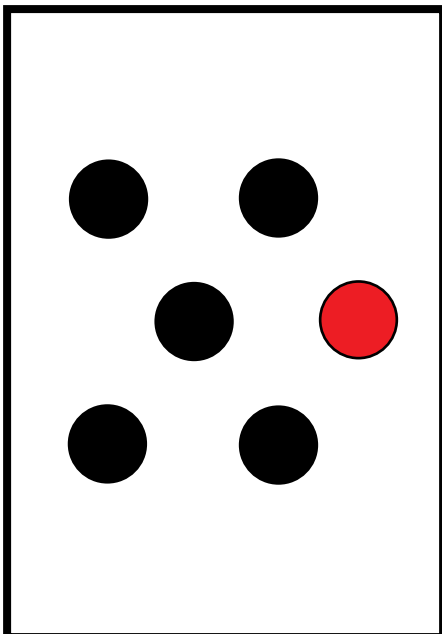
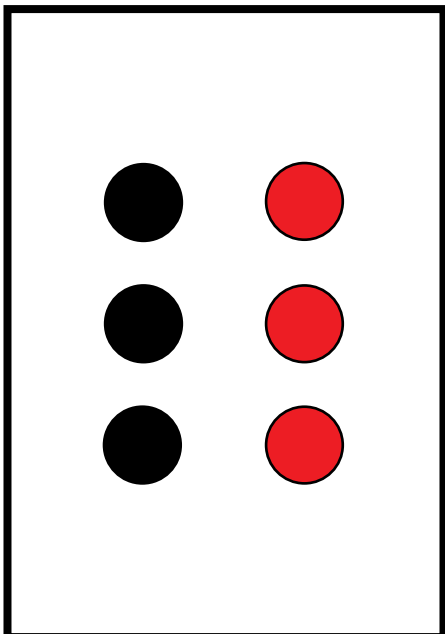
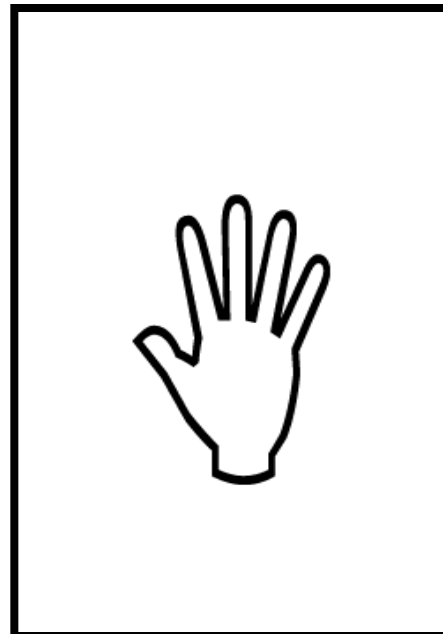
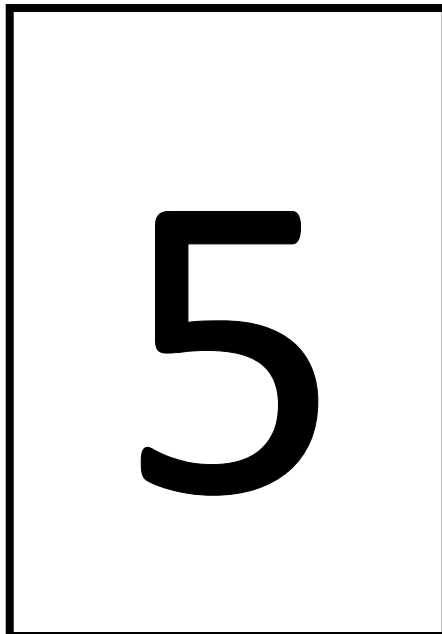
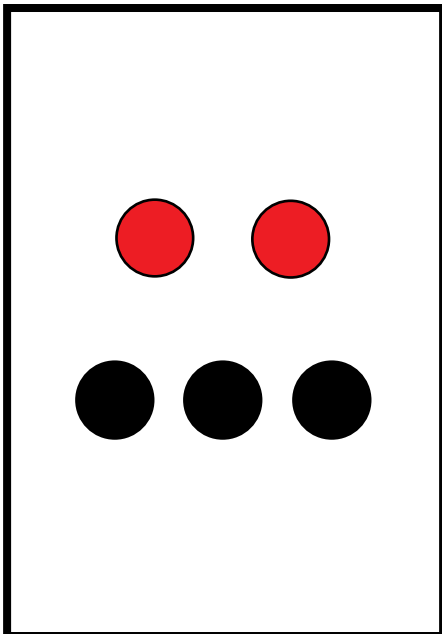
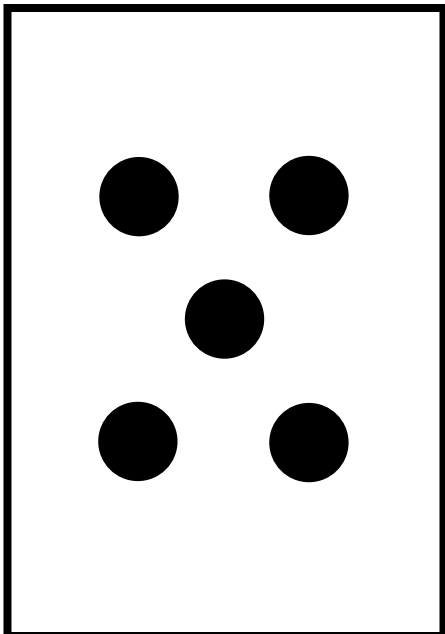

# Cartes de représentations imagée et symbolique des nombres - Appariements (1 à 10) (suite)

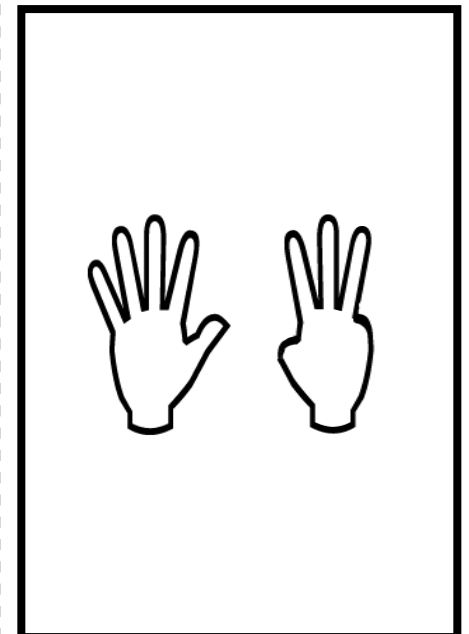
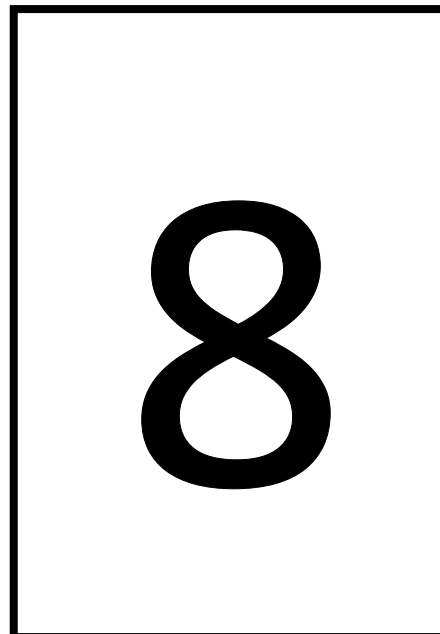
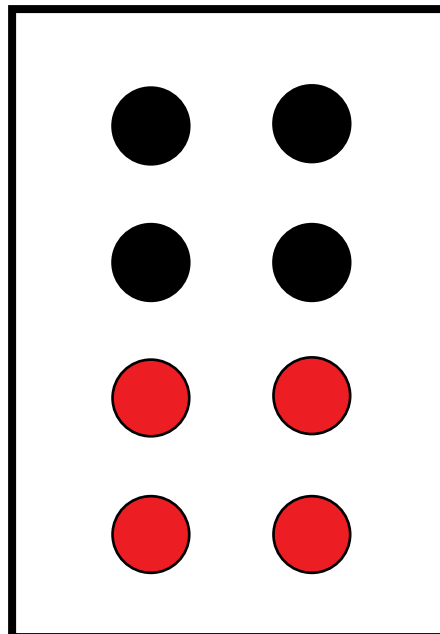
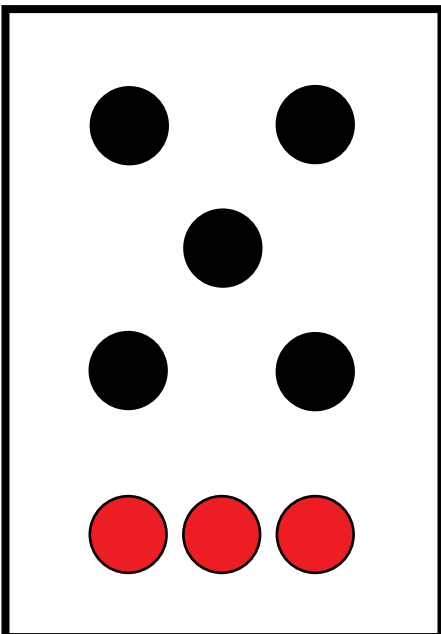
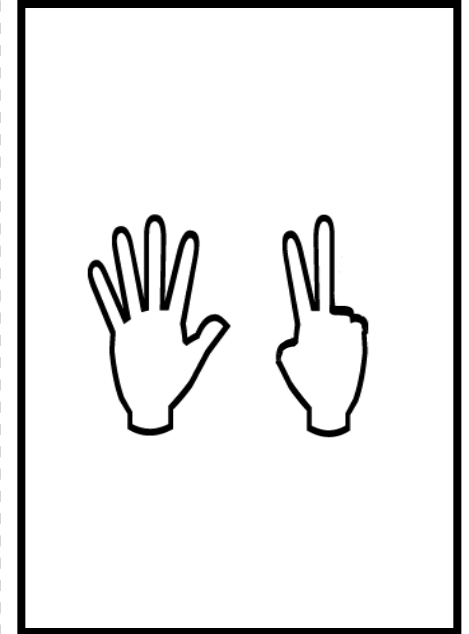
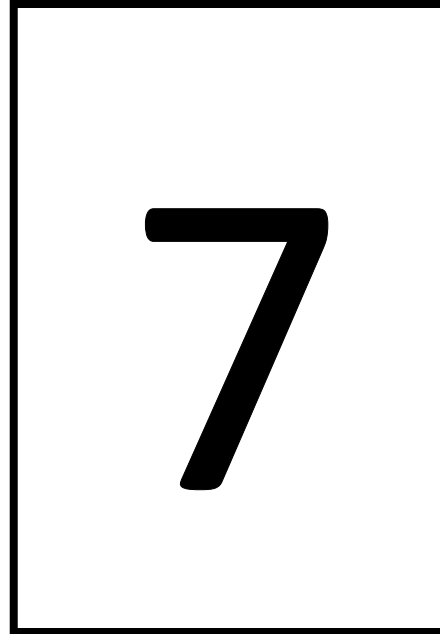
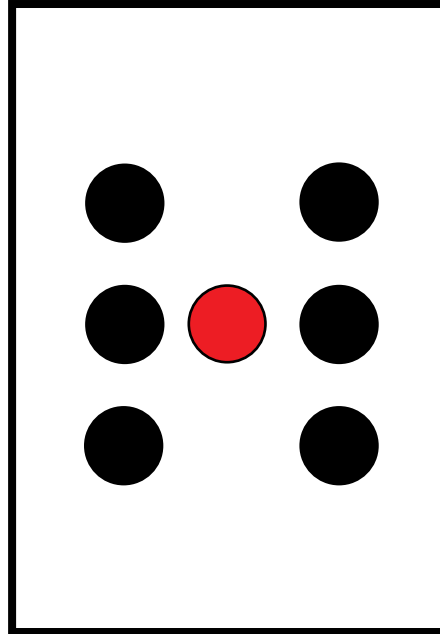
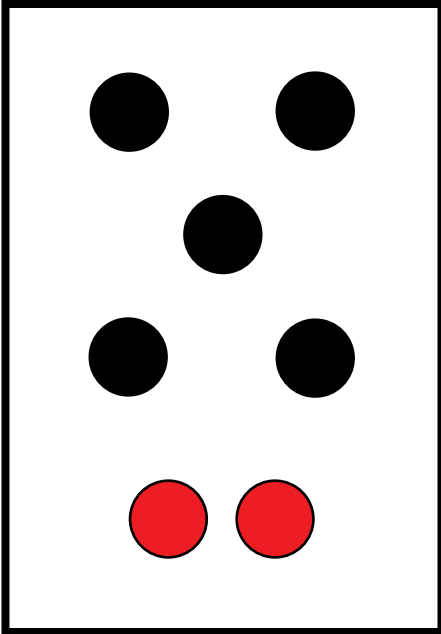



# Cartes de représentations imagée et symbolique des nombres - Appariements (1 à 10) (suite)

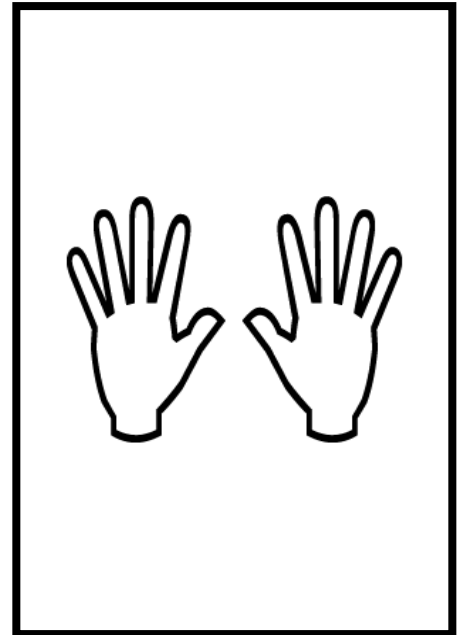
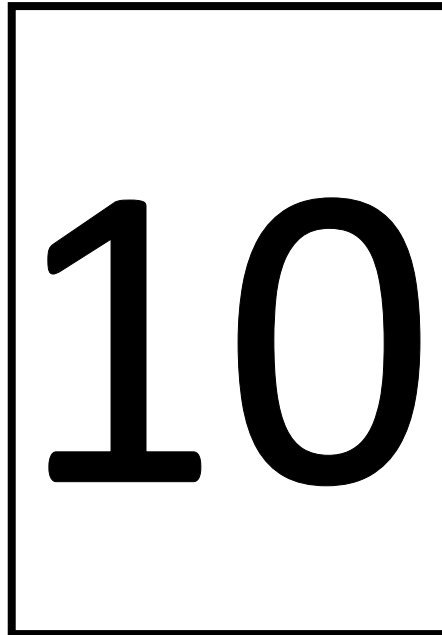
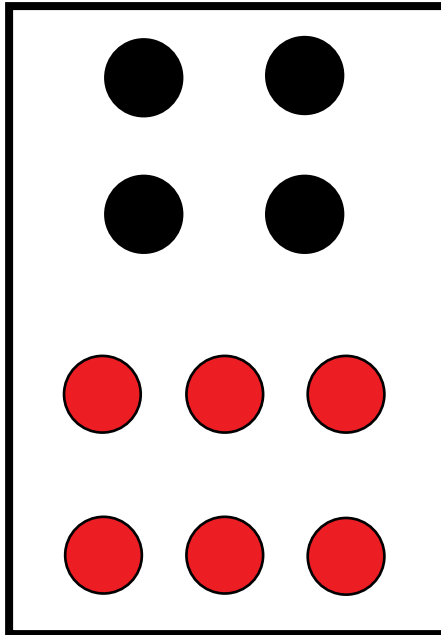
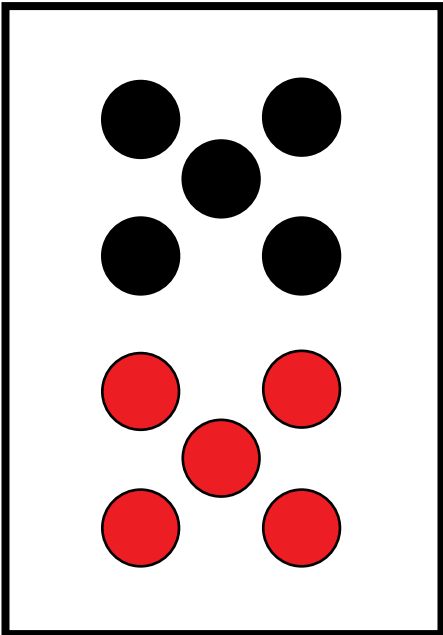
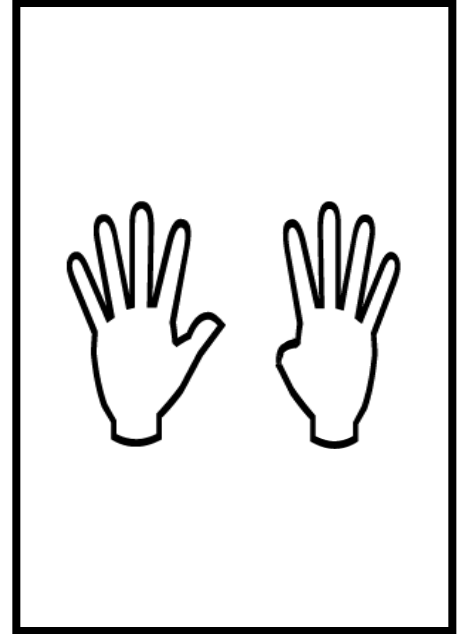
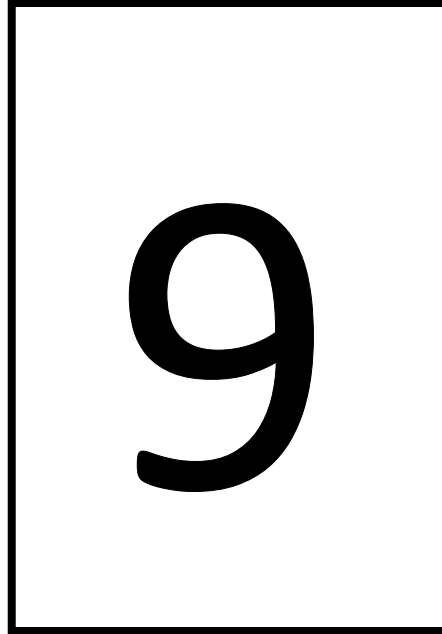
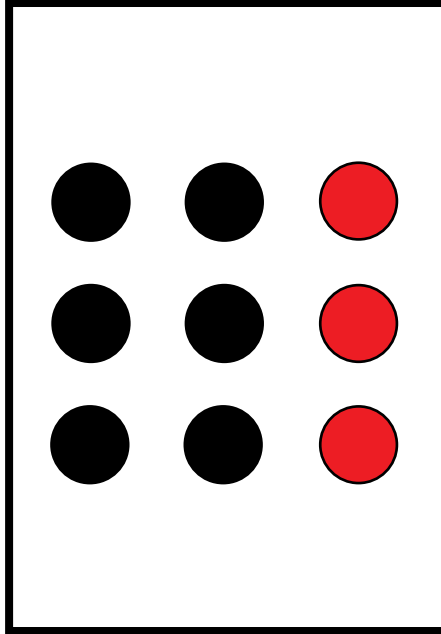
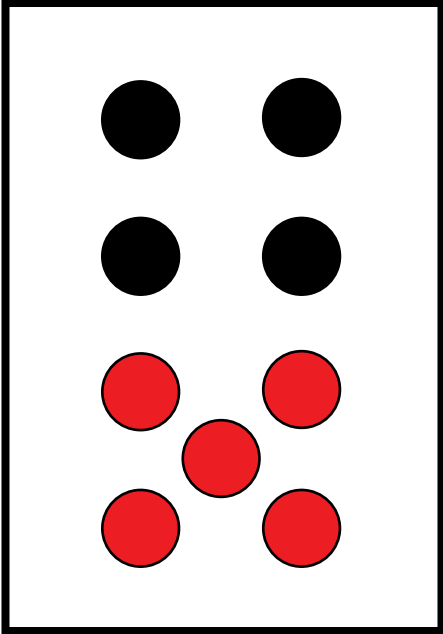

# Cartes de représentations imagée et symbolique des nombres

## Chiffres et en lettres (1 à 20)

<b>1</b>	<b>2</b>	<b>3</b>	<b>4</b>	<b>5</b>
<b>6</b>	<b>7</b>	<b>8</b>	<b>9</b>	<b>10</b>
<b>11</b>	<b>12</b>	<b>13</b>	<b>14</b>	<b>15</b>
<b>16</b>	<b>17</b>	<b>18</b>	<b>19</b>	<b>20</b>

**Cartes de représentations imagée et symbolique des nombres**  
**Chiffres et en lettres (1 à 20) (suite)**

<b>un</b>	<b>six</b>
<b>deux</b>	<b>sept</b>
<b>trois</b>	<b>huit</b>
<b>quatre</b>	<b>neuf</b>
<b>cing</b>	<b>dix</b>

Cartes de représentations imagée et symbolique des nombres  
Chiffres et en lettres (1 à 20) (suite)

<b>onze</b>	<b>seize</b>
<b>douze</b>	<b>dix-sept</b>
<b>treize</b>	<b>dix-huit</b>
<b>quatorze</b>	<b>dix-neuf</b>
<b>quinze</b>	<b>vingt</b>

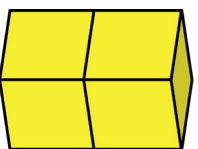
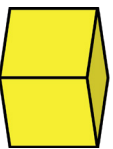
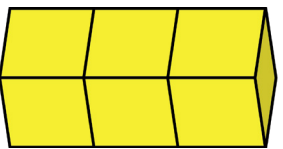

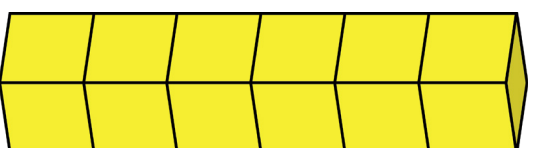
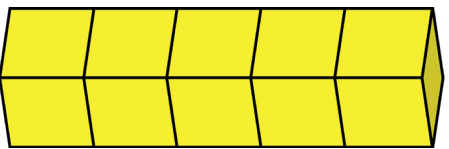
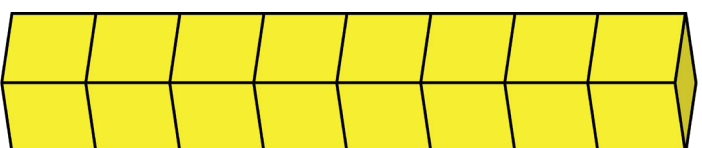
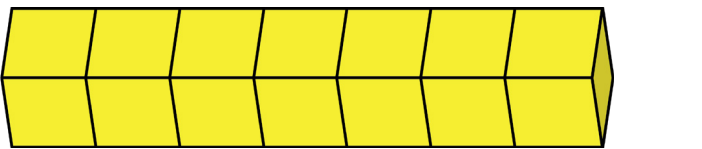

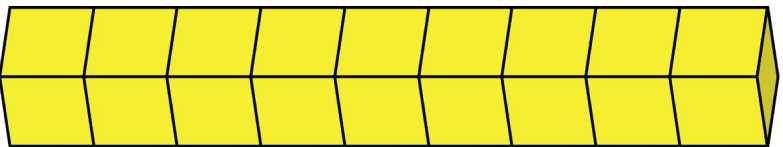
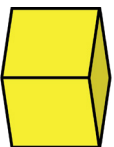
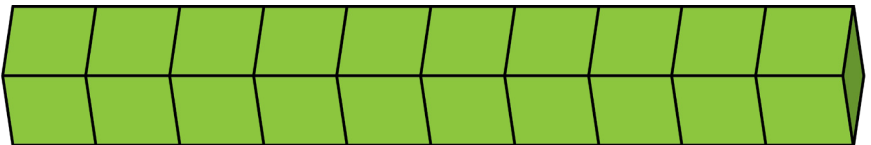

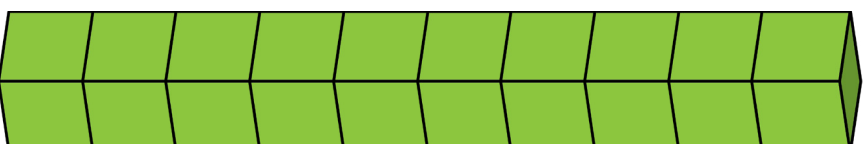
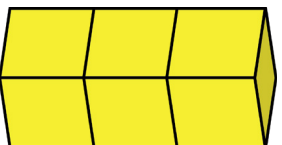
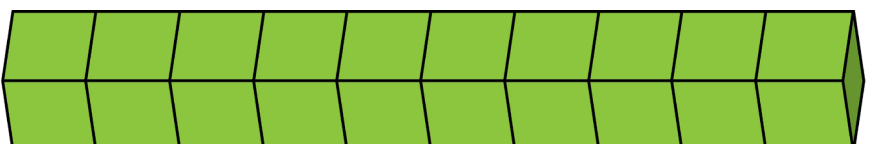
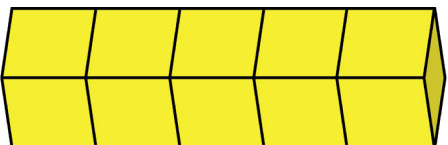



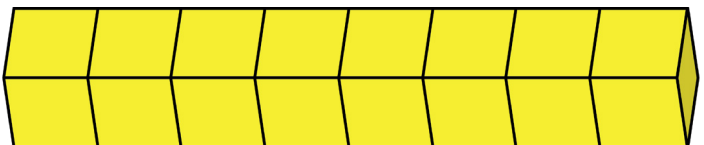
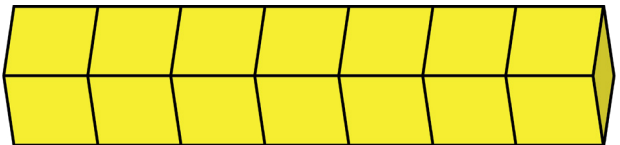
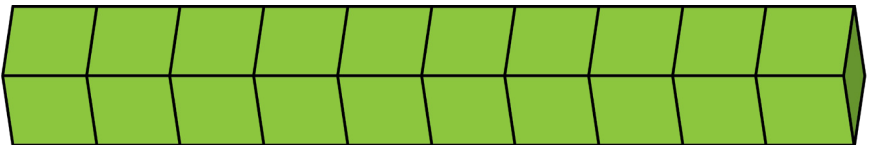
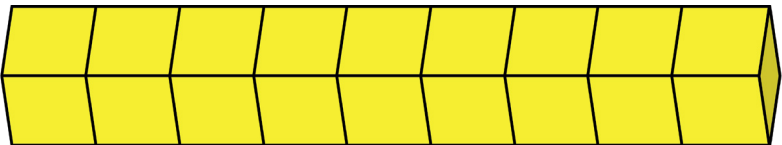
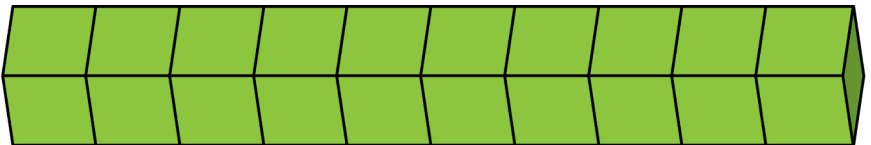

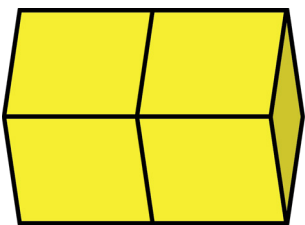
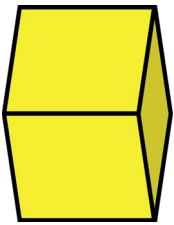

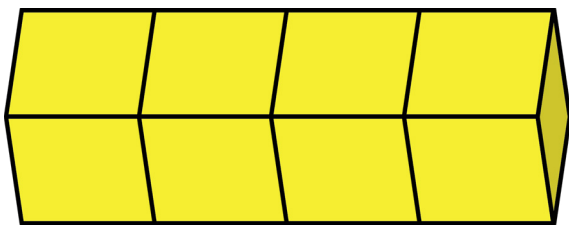
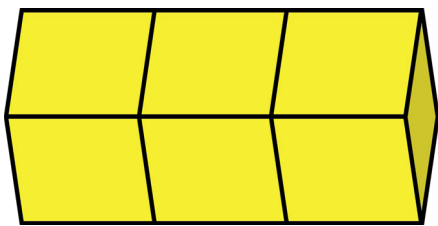

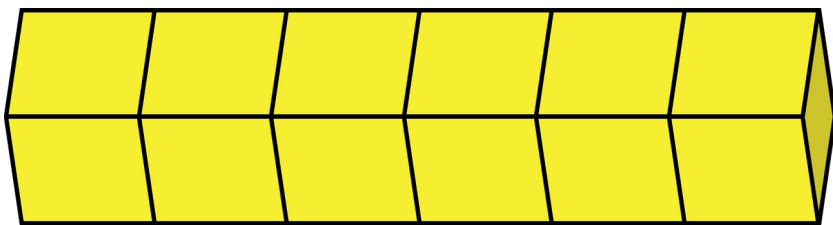
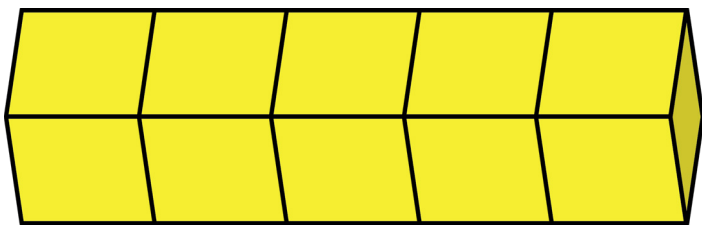

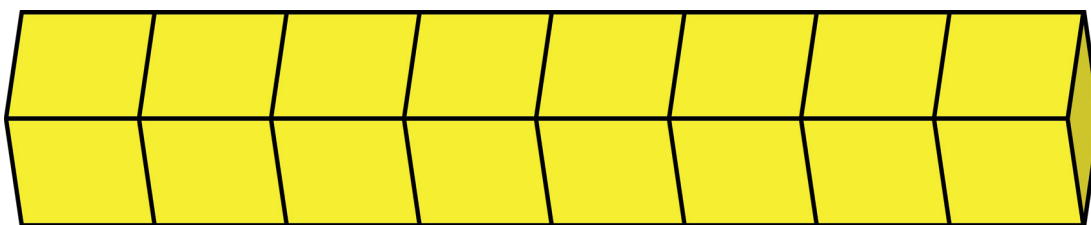
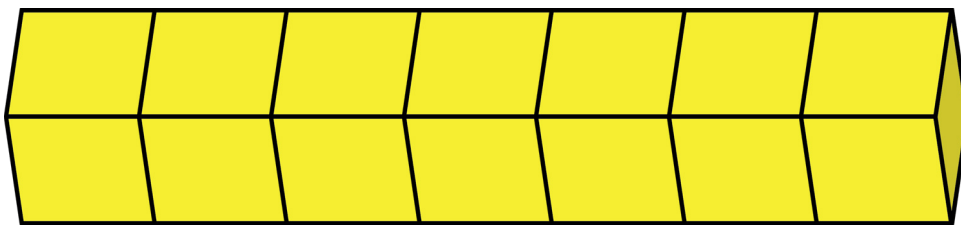

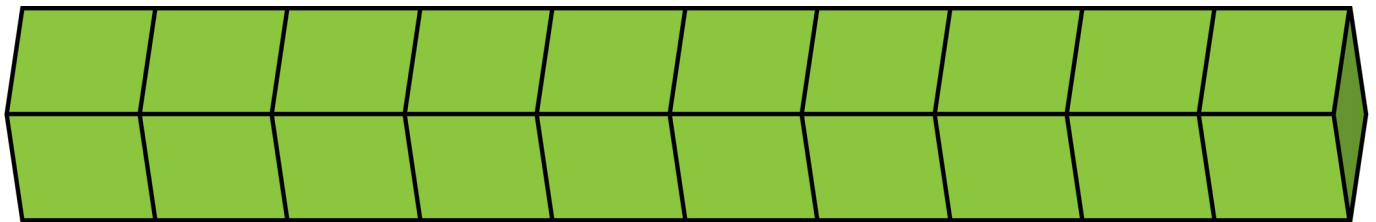
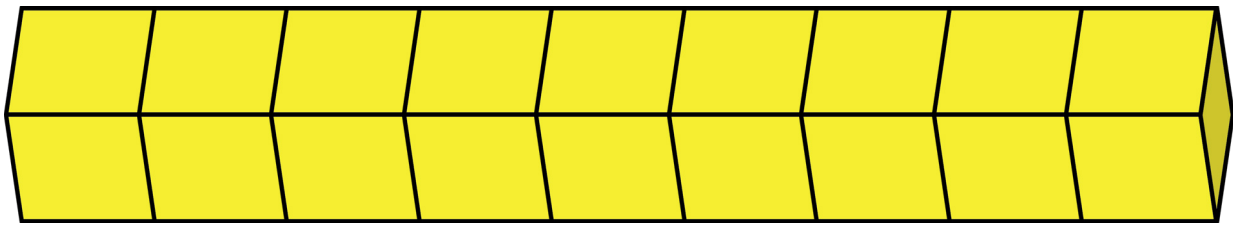

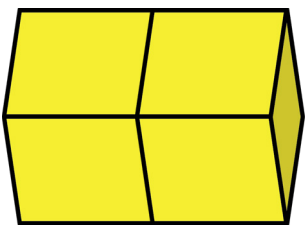
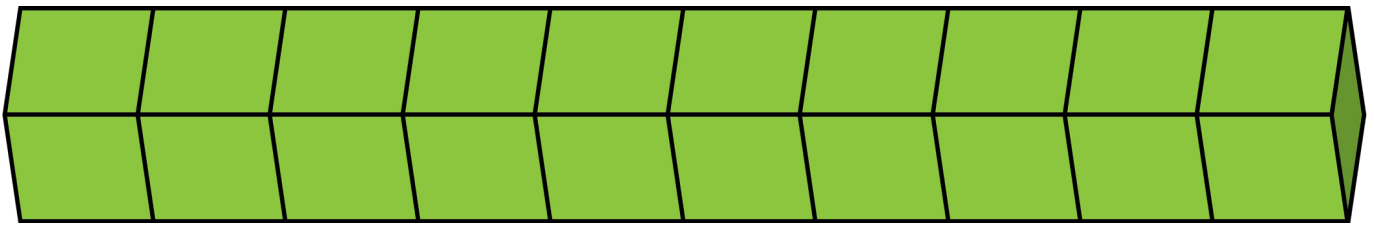
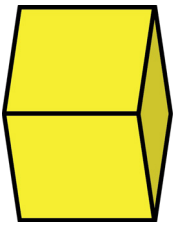
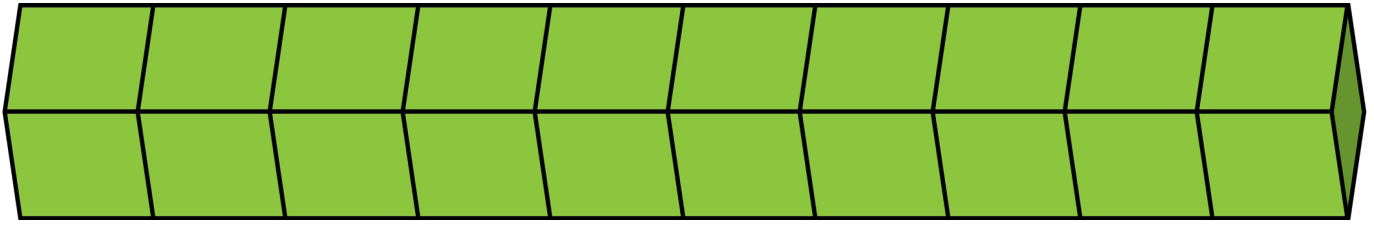

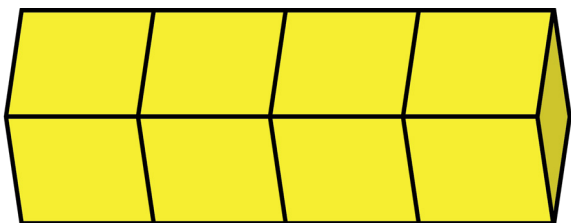
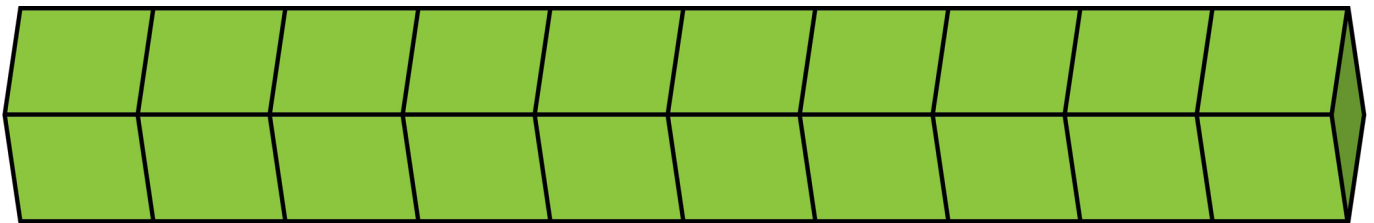
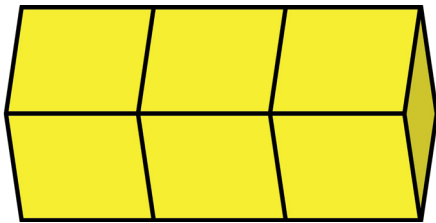
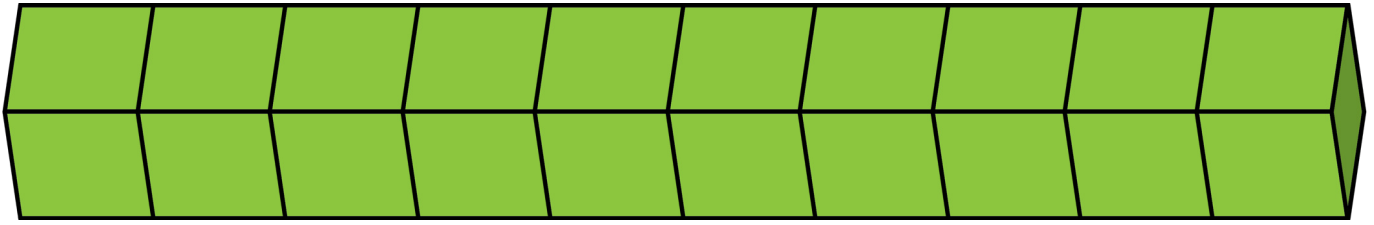



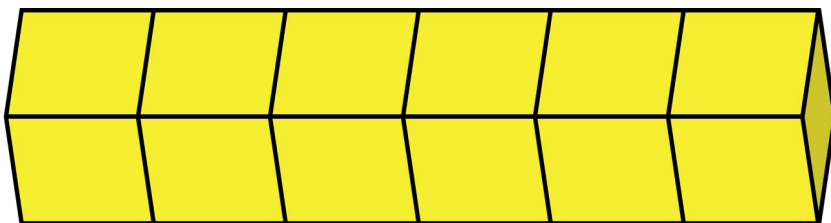
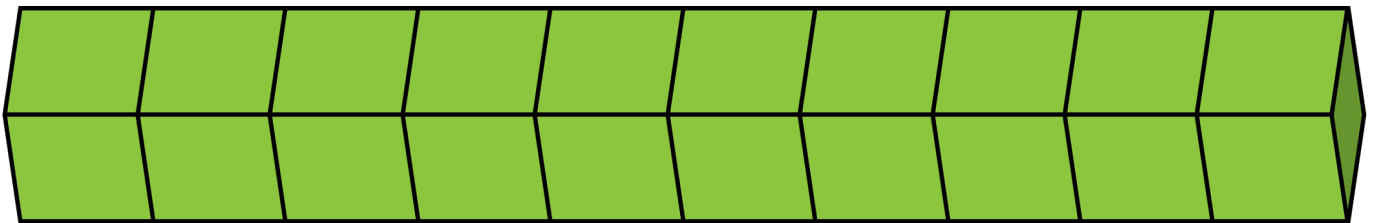
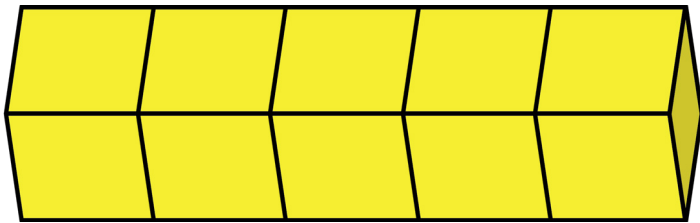
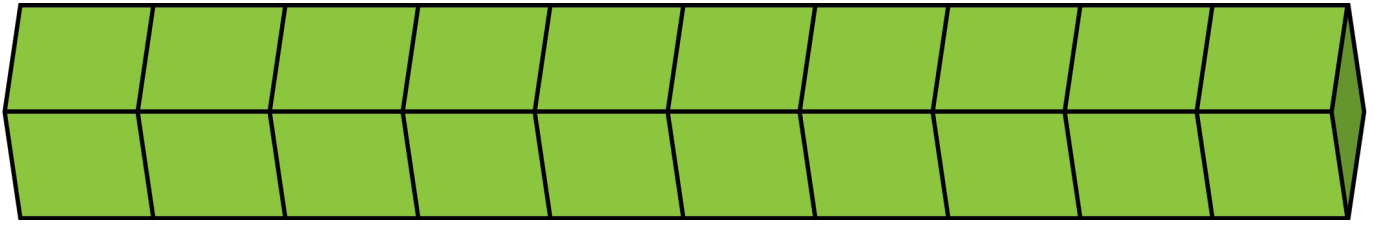

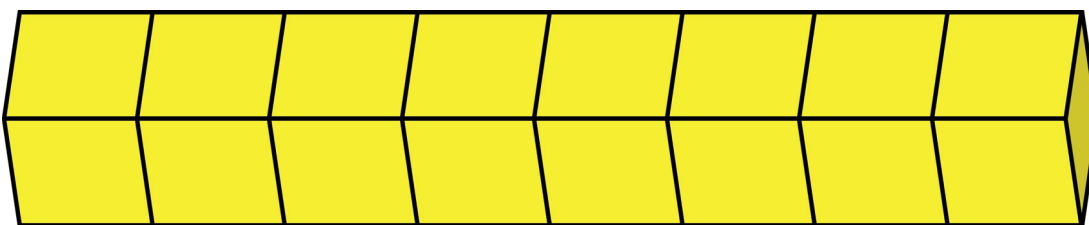
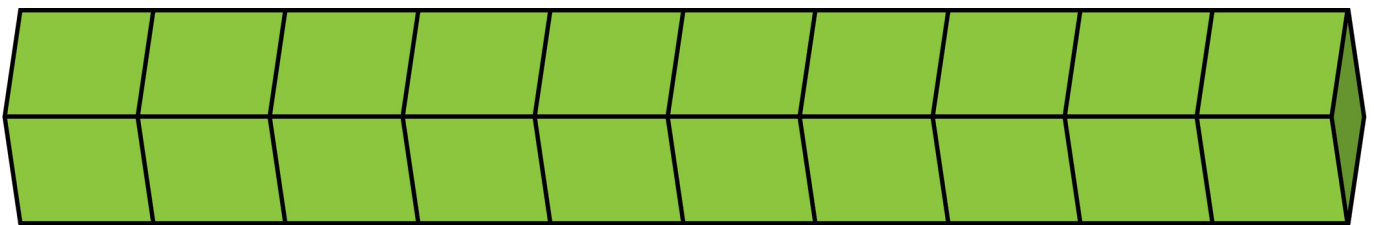
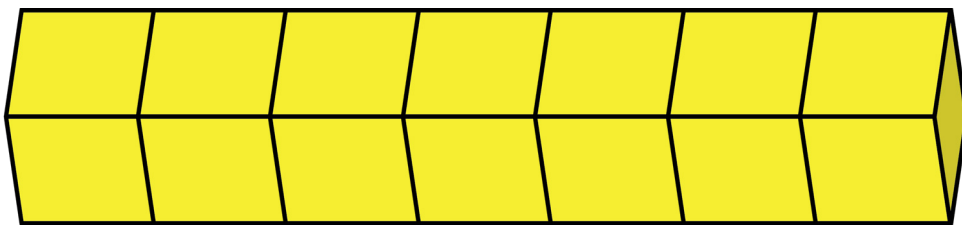
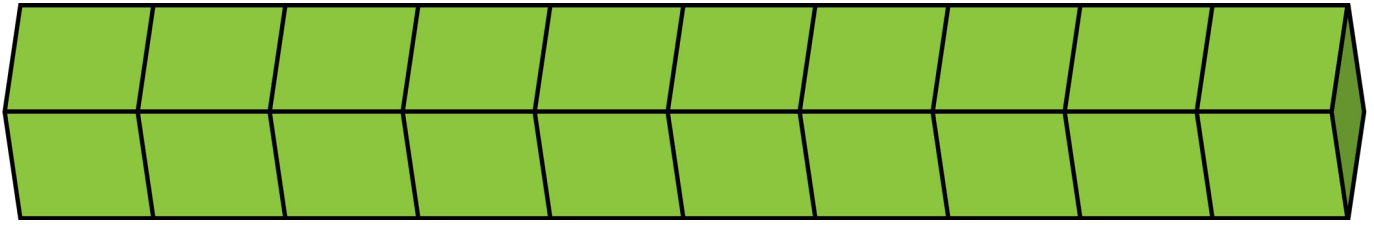

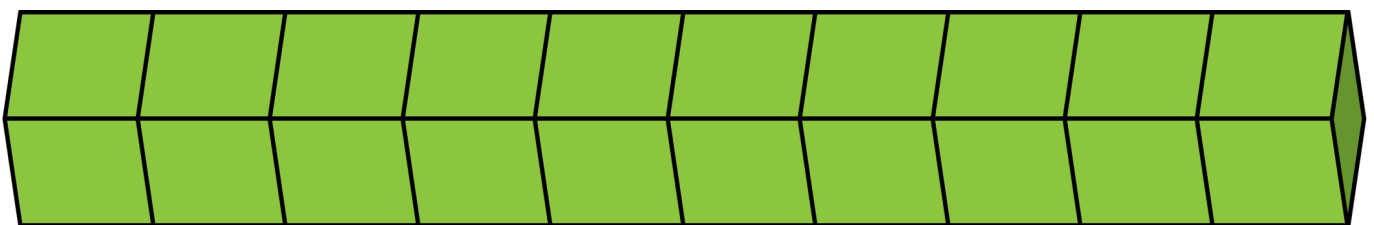
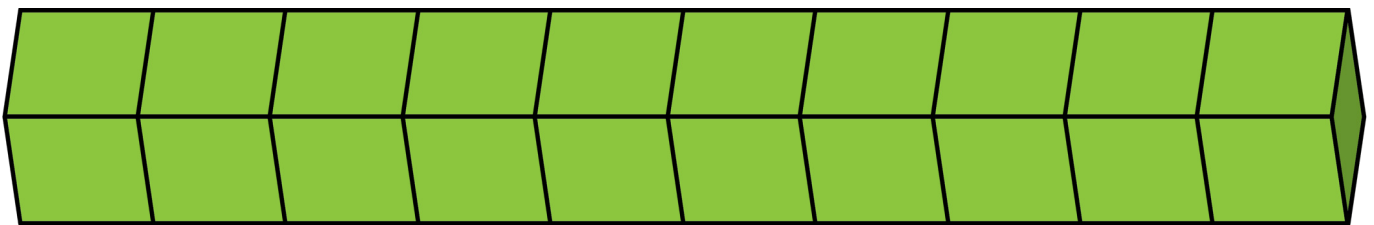
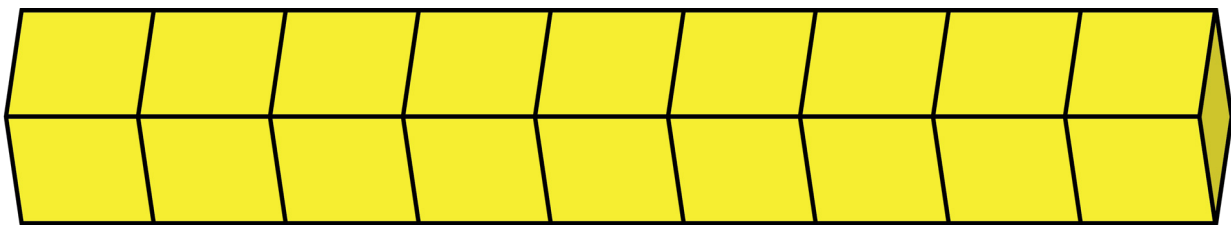
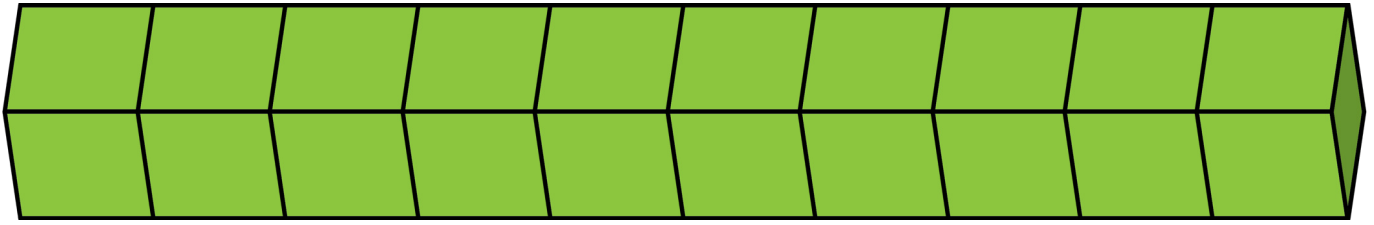

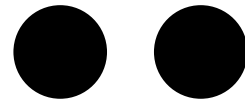
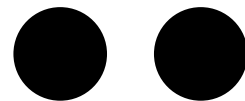
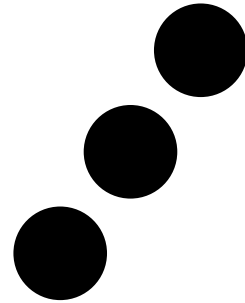

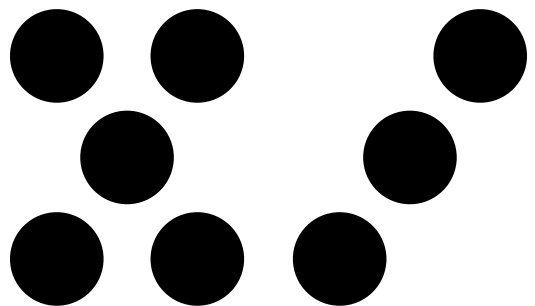
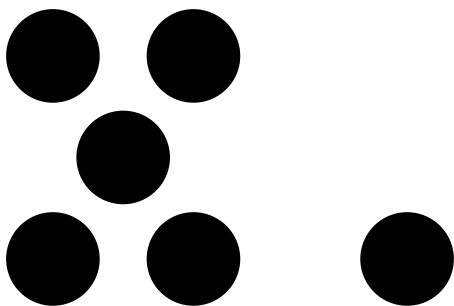
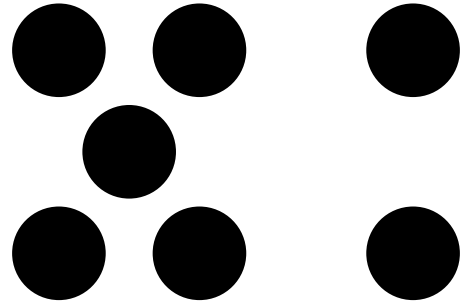
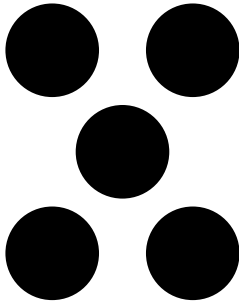

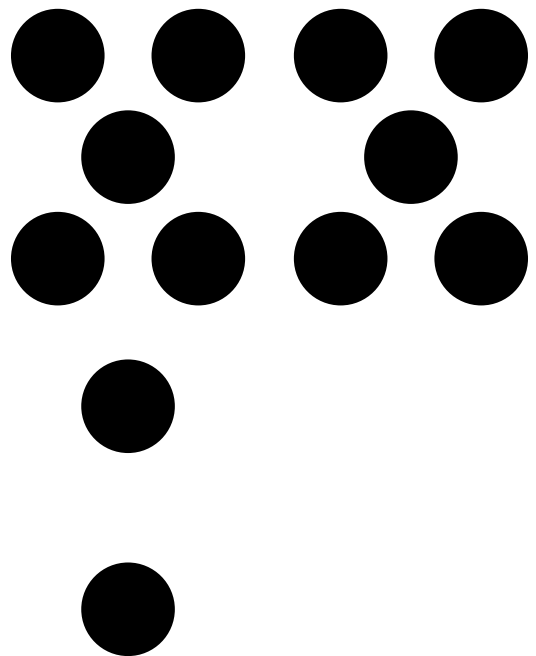
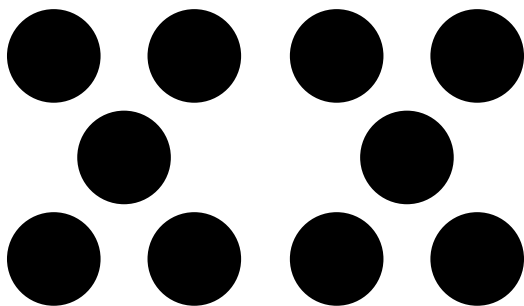
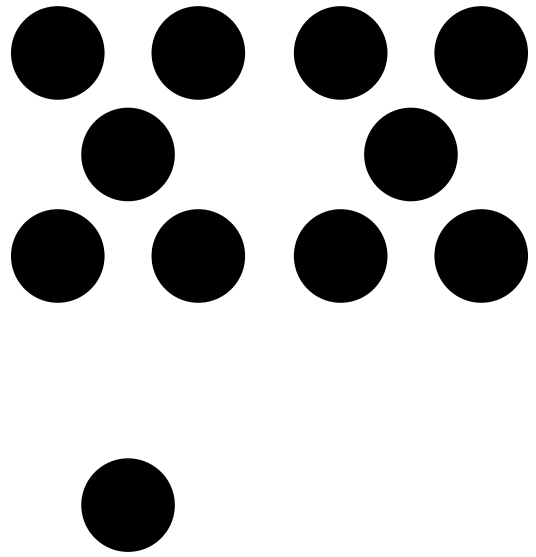
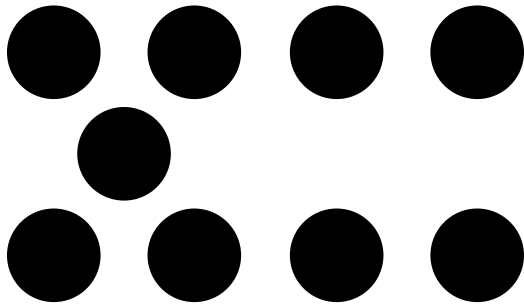

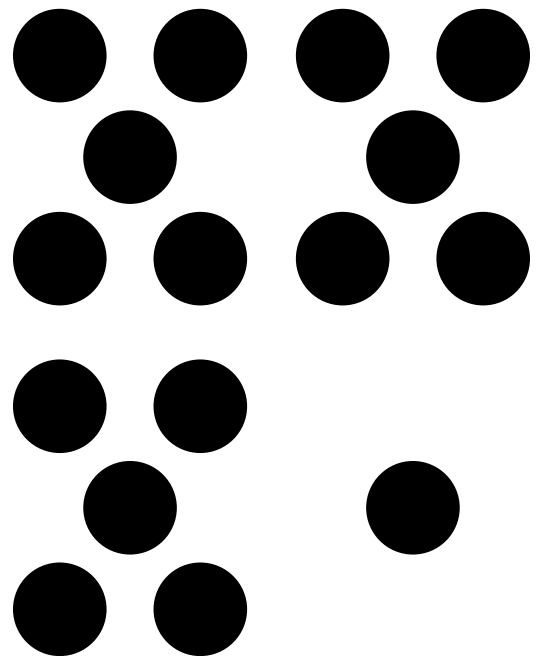
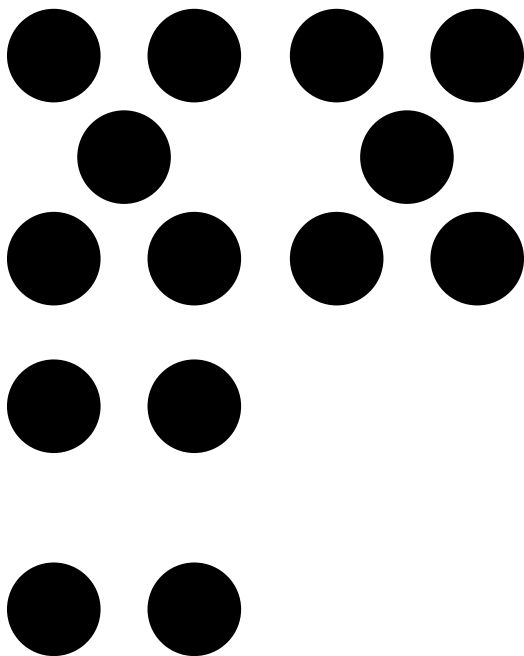
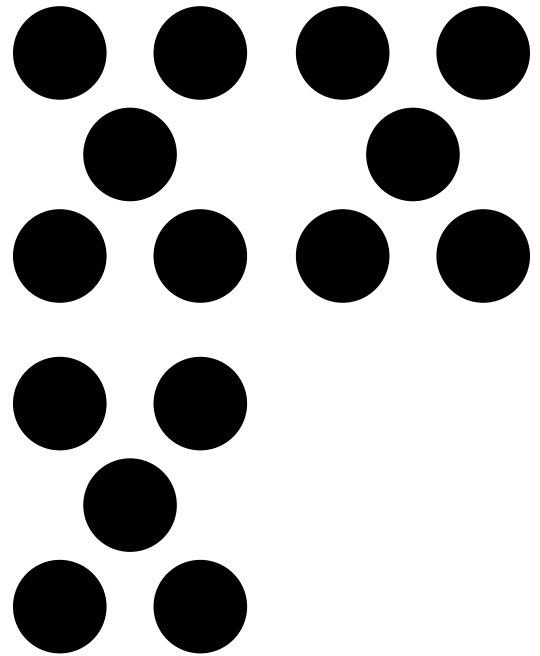
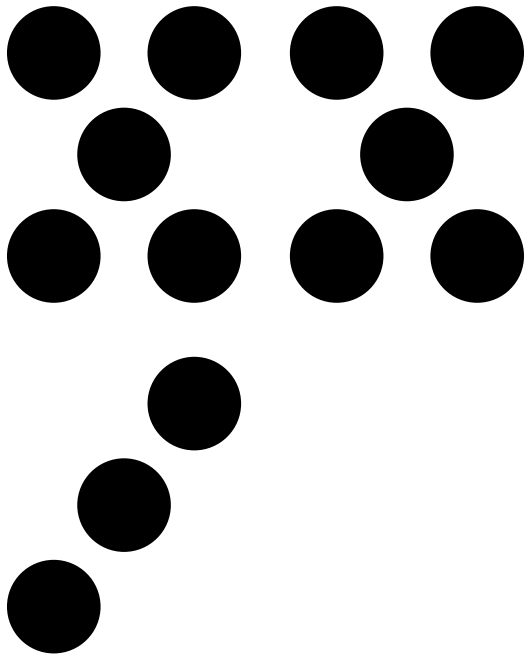

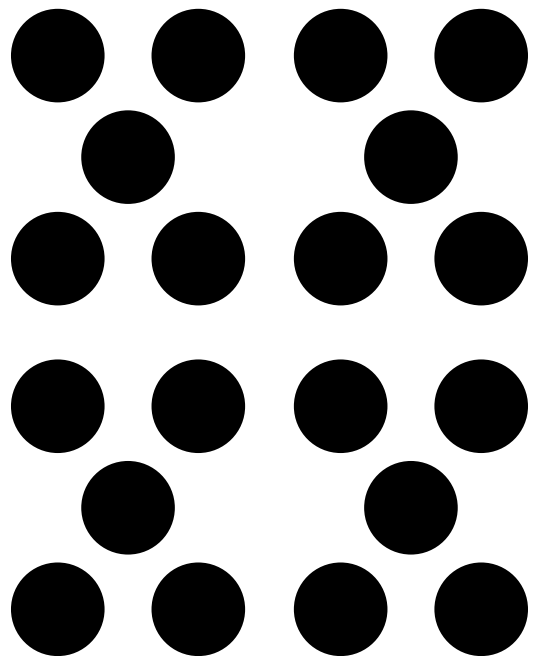
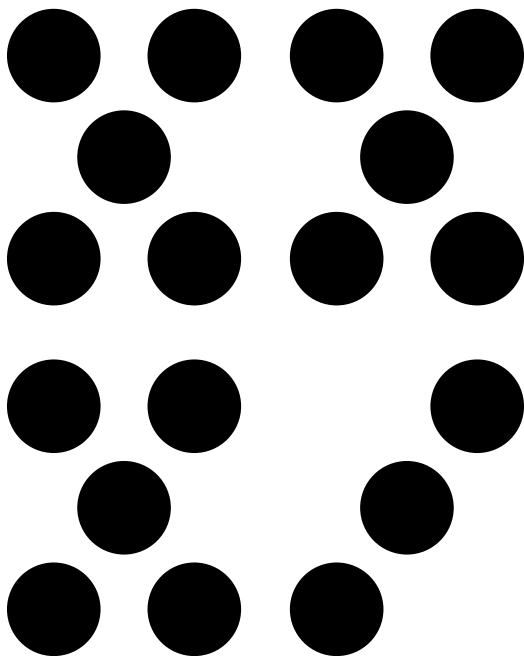
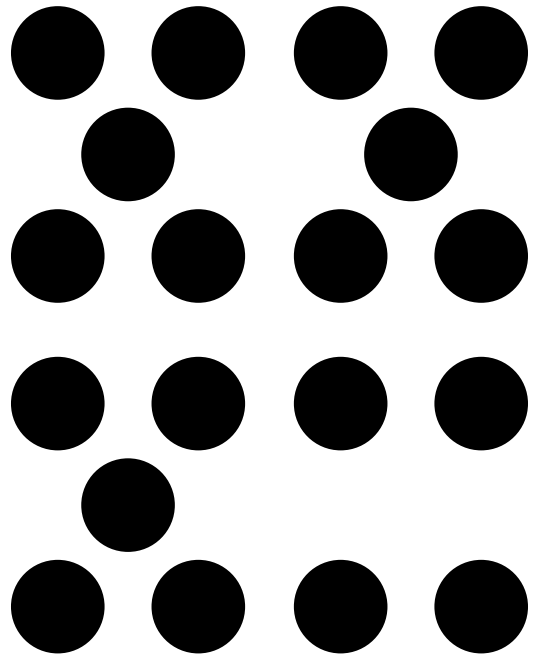
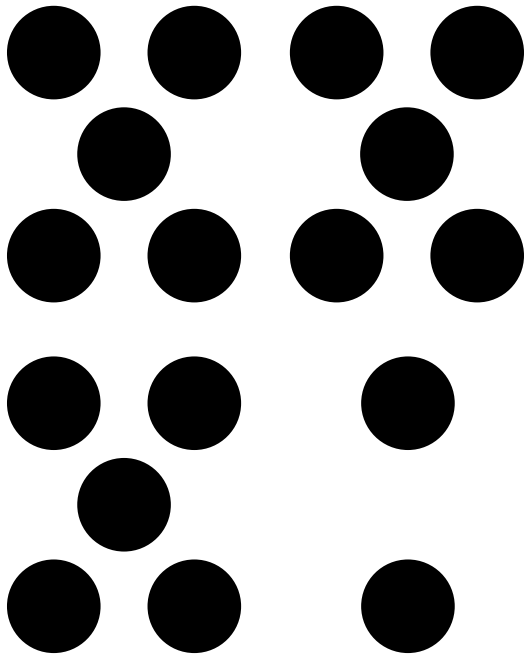



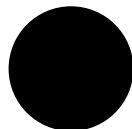
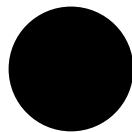
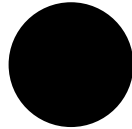

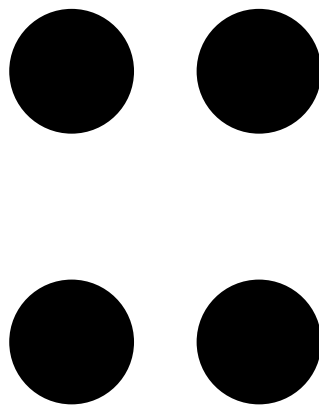
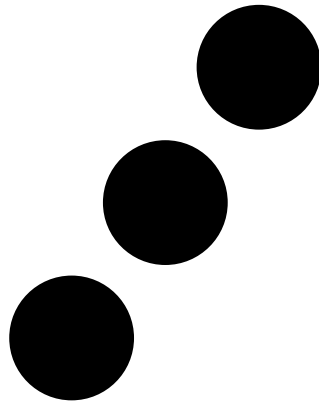

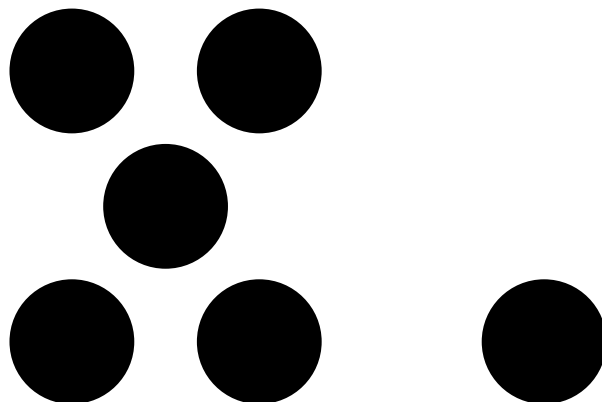
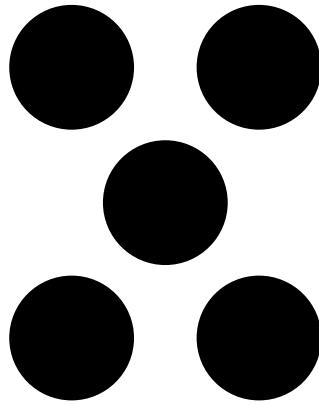

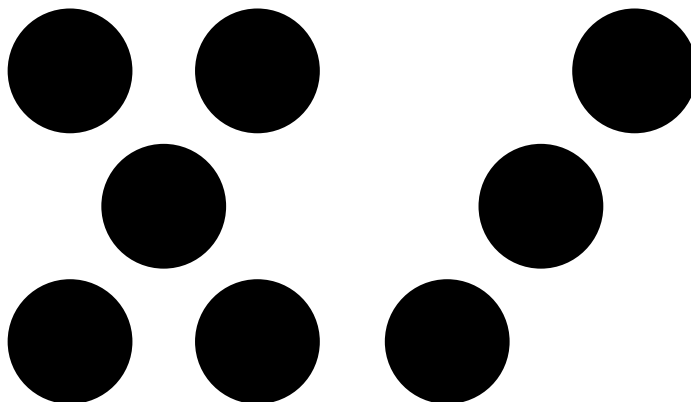
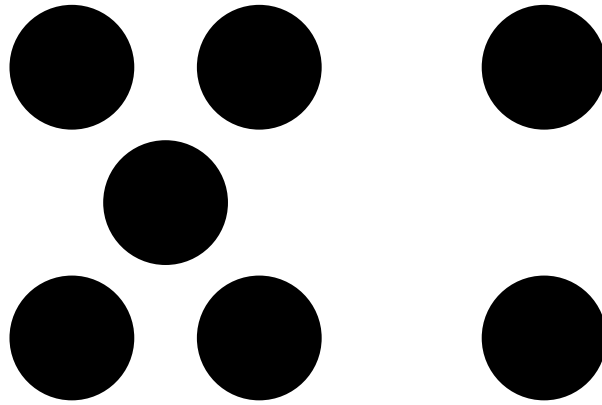

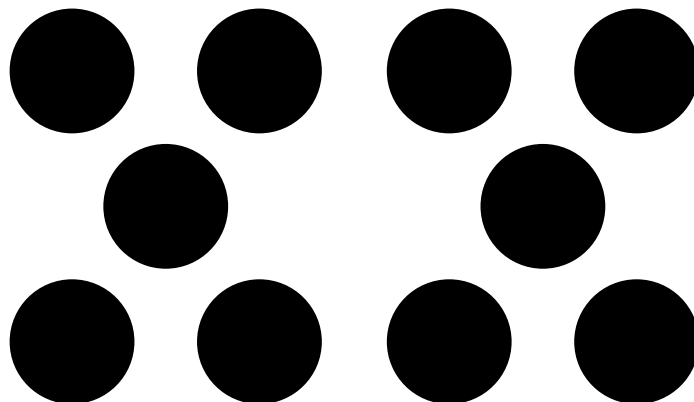
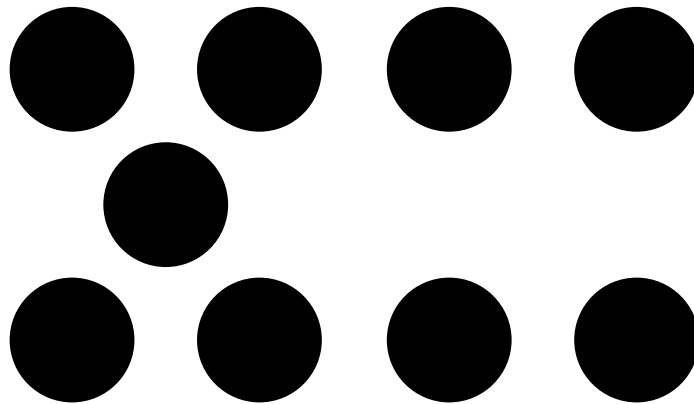

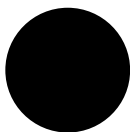
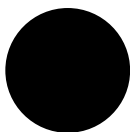
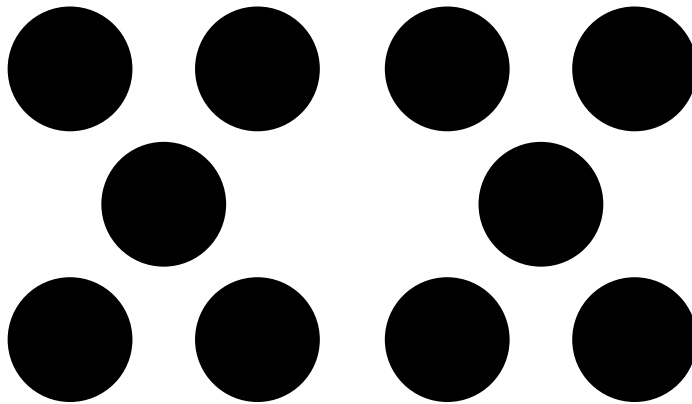
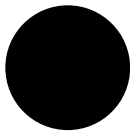
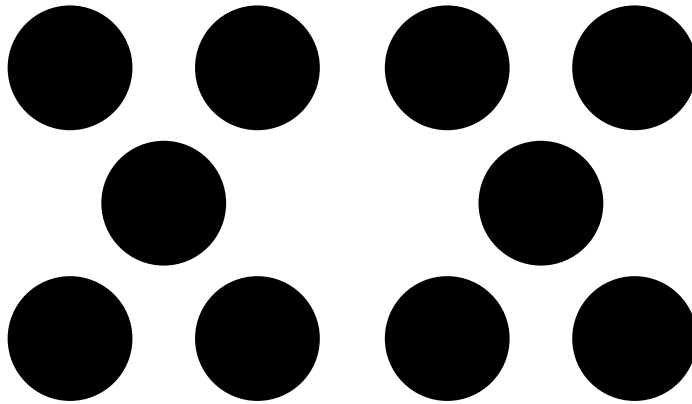

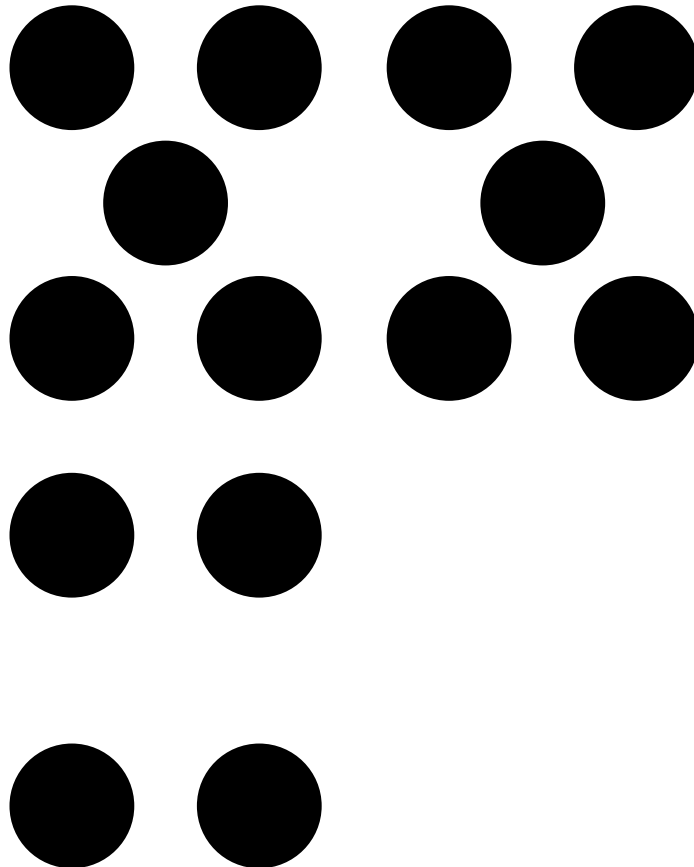
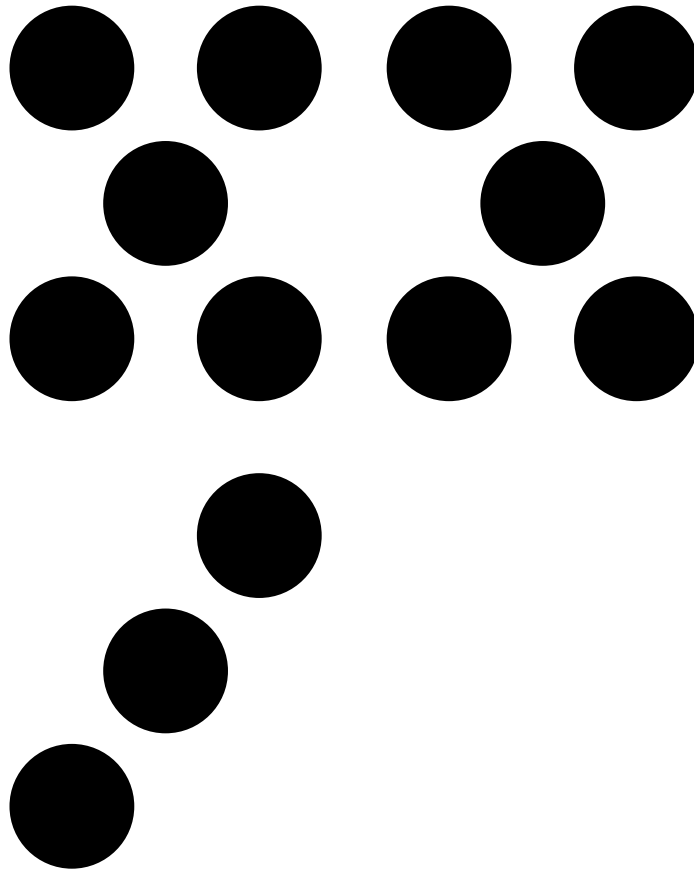

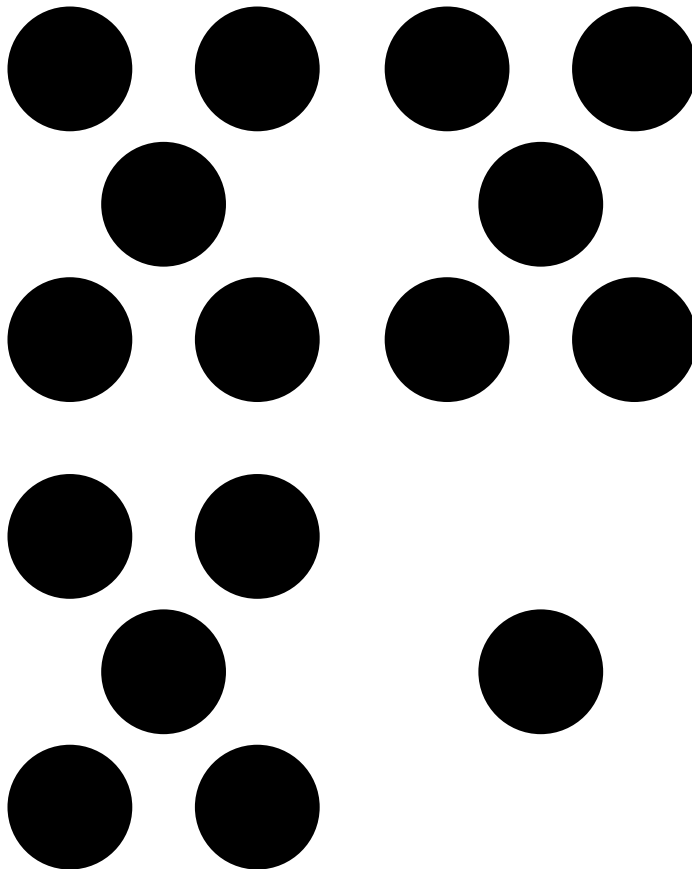
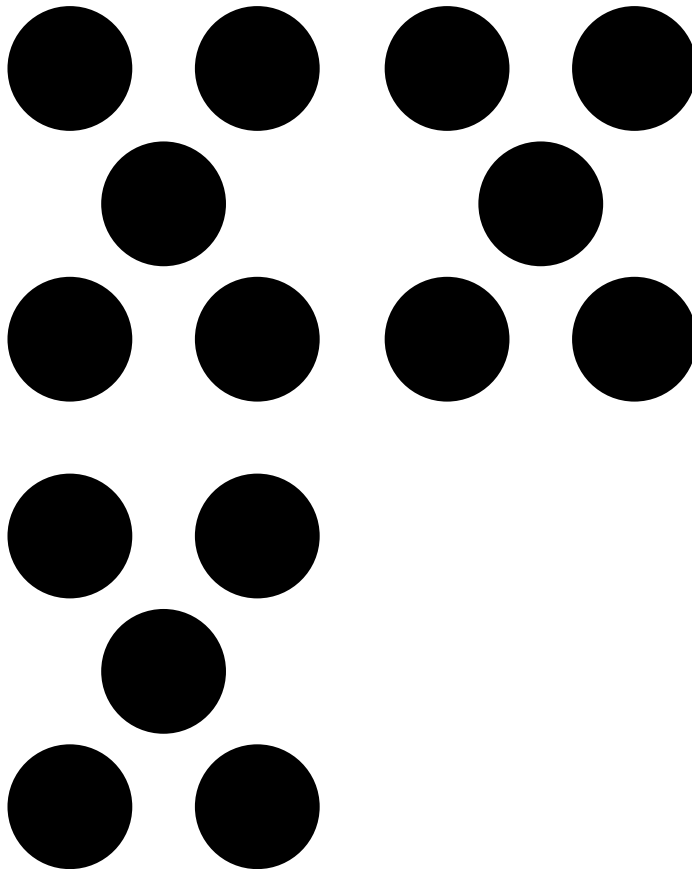



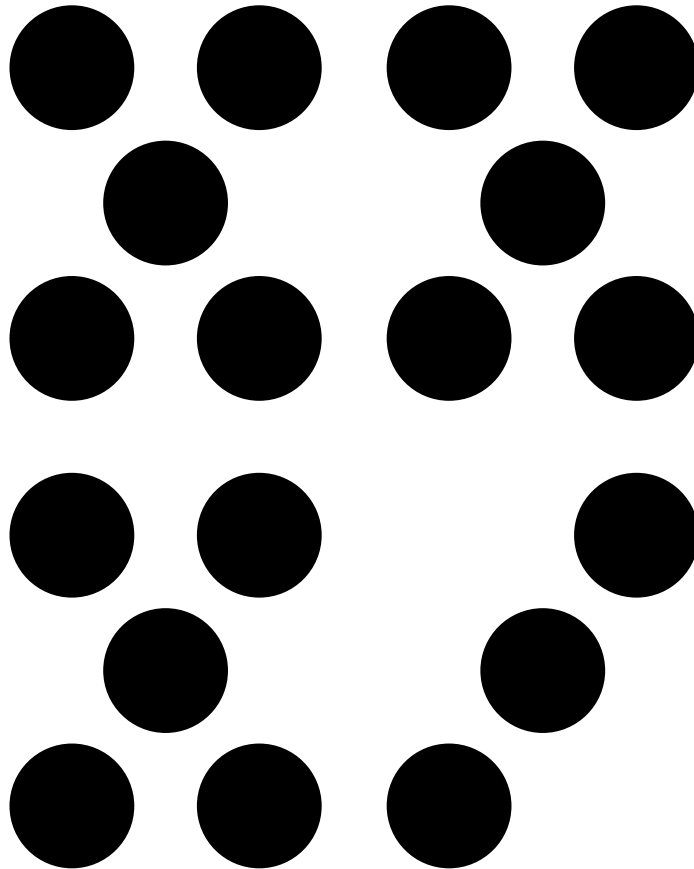
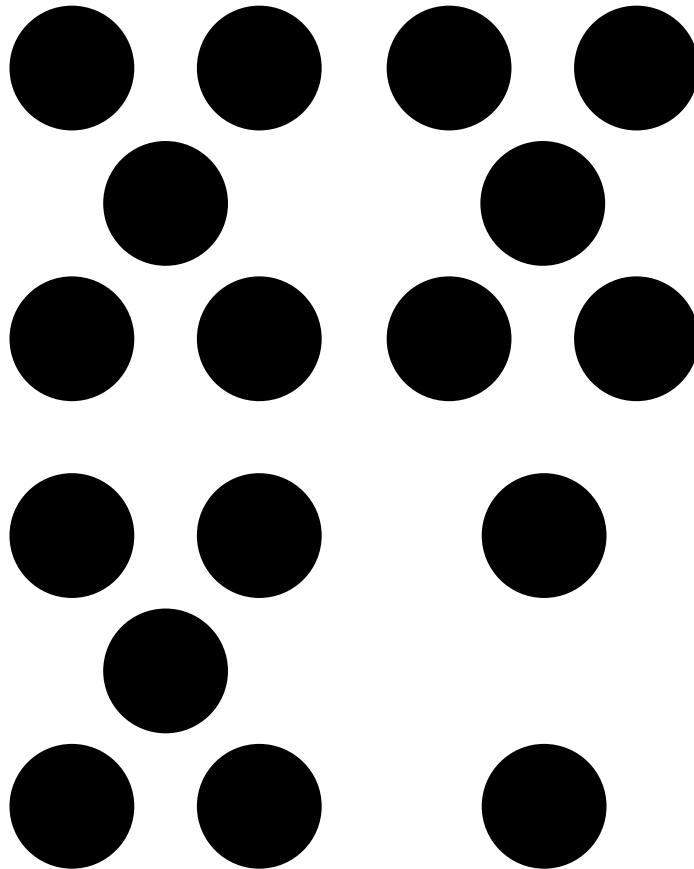

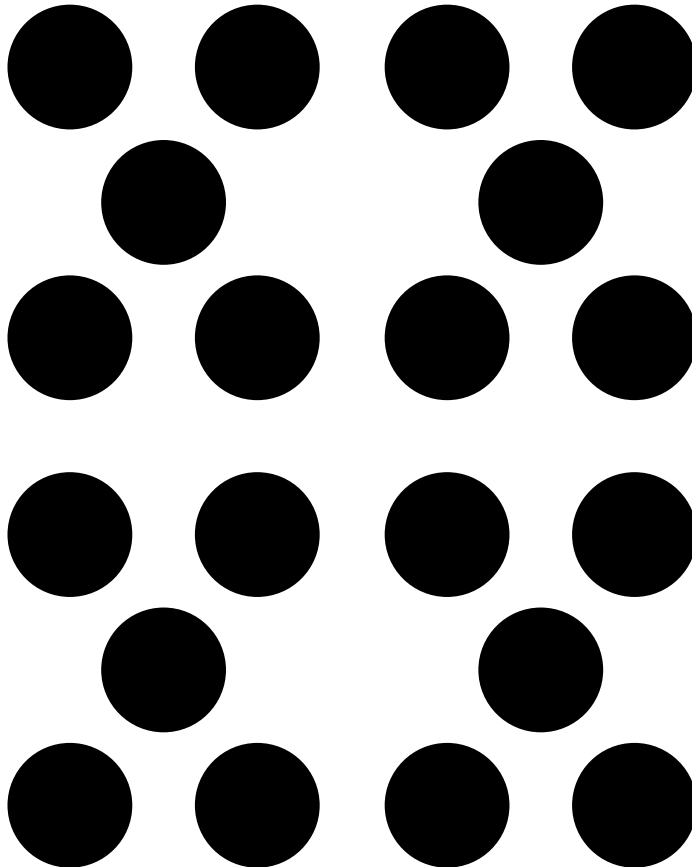
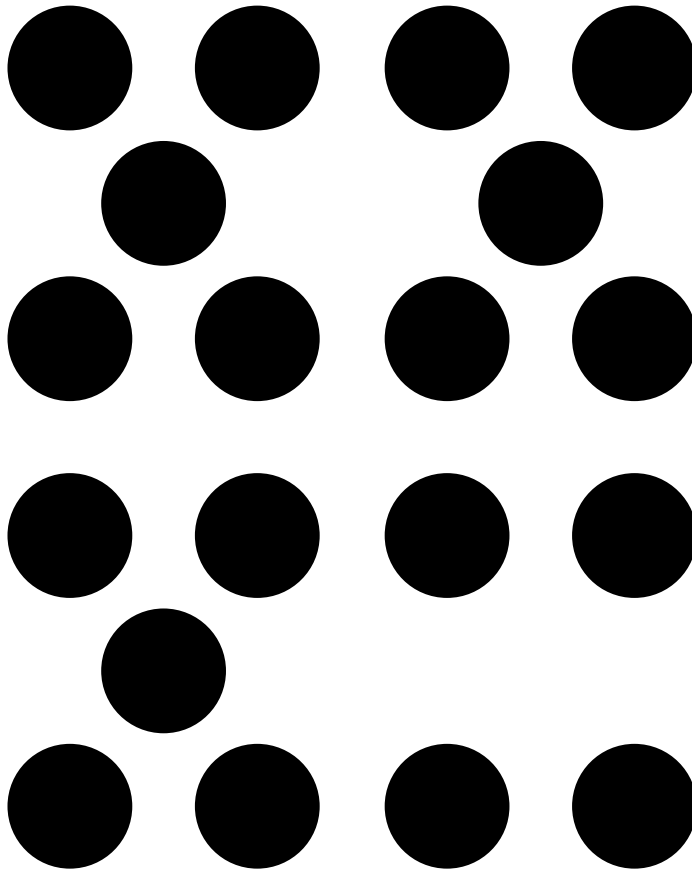

3

4

1

2



7

8

5

6



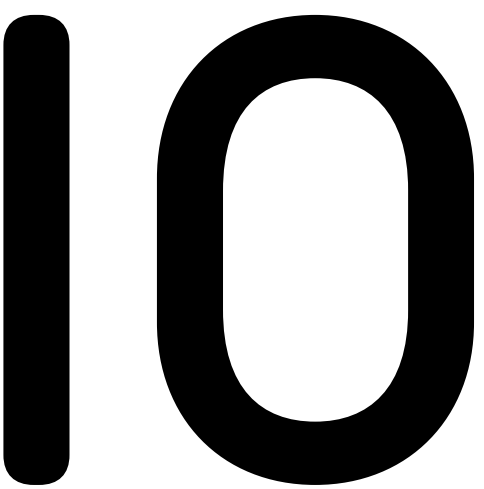
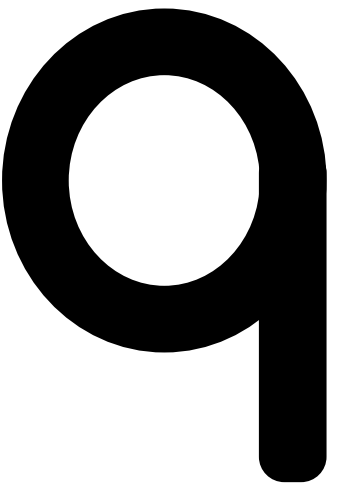
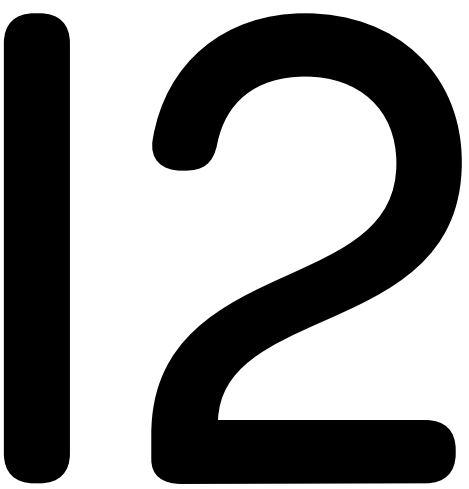
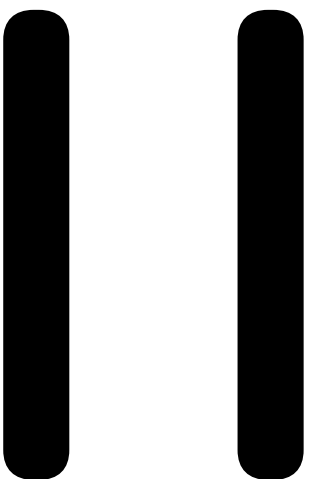

15

16

13

14



19

20

17

18









3



4





5



6





7



8



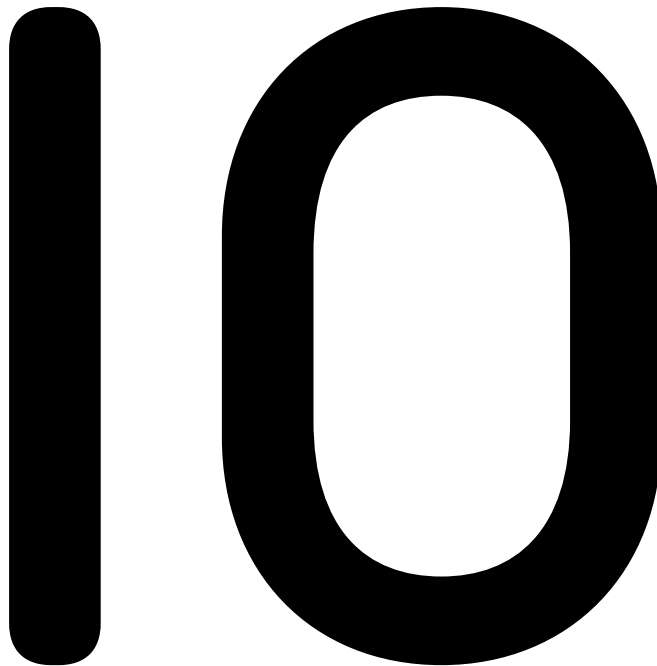
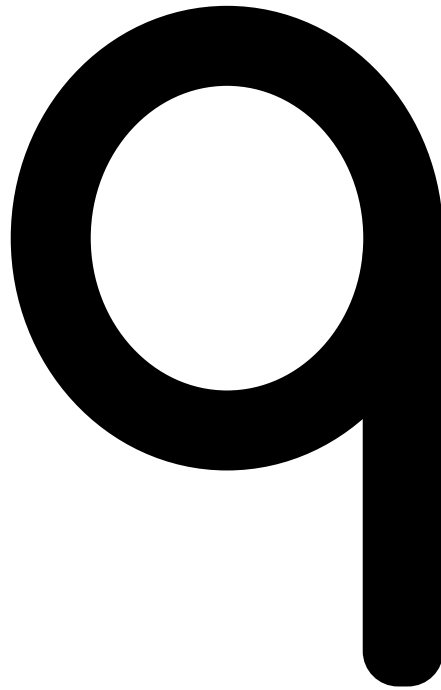

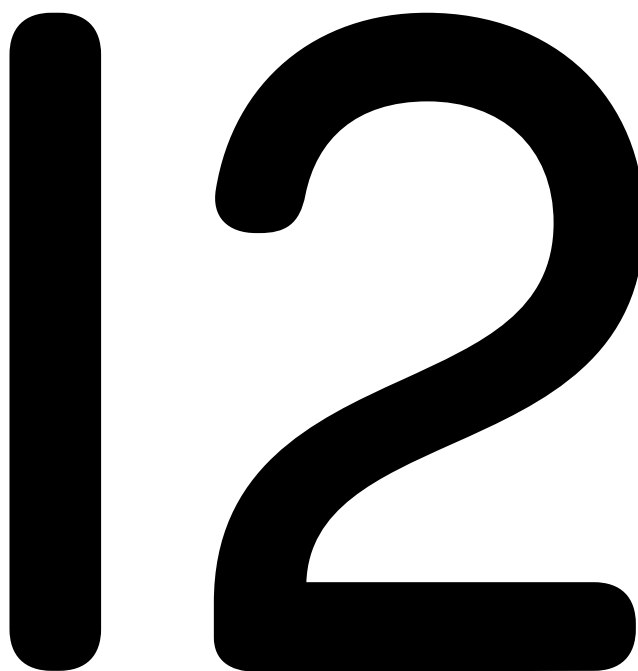
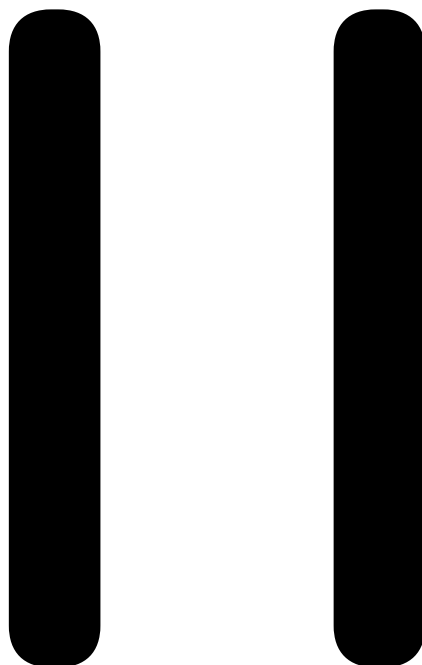



13



14





15



16





17



18







19



20



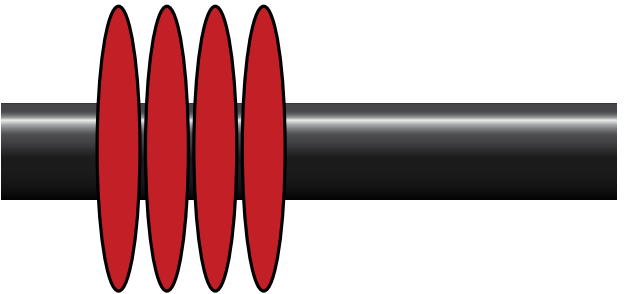
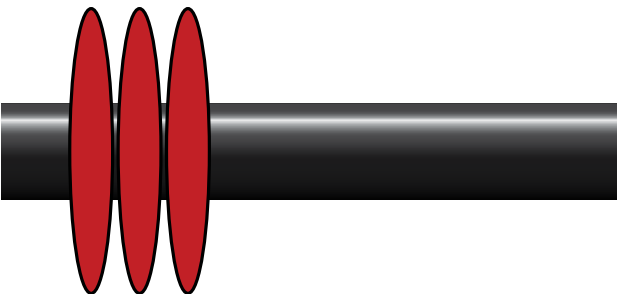

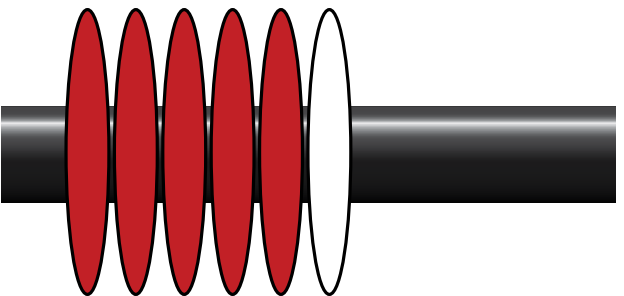
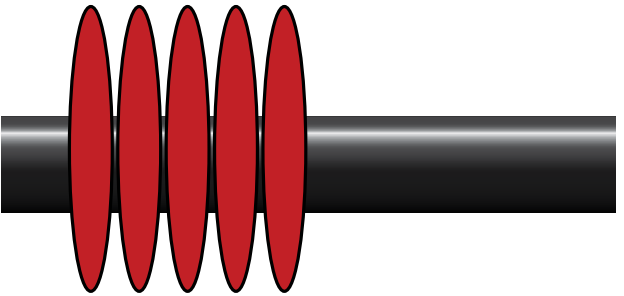
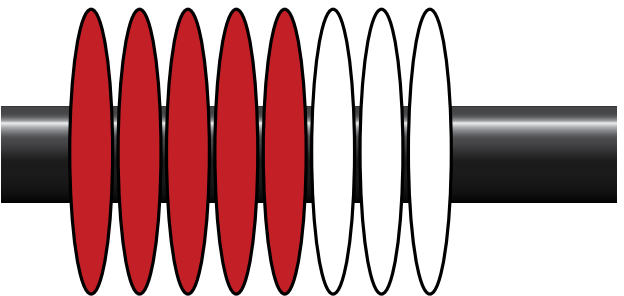
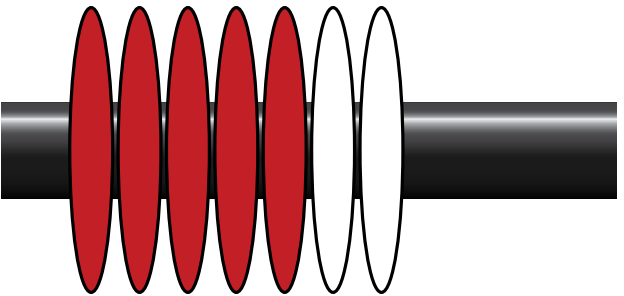

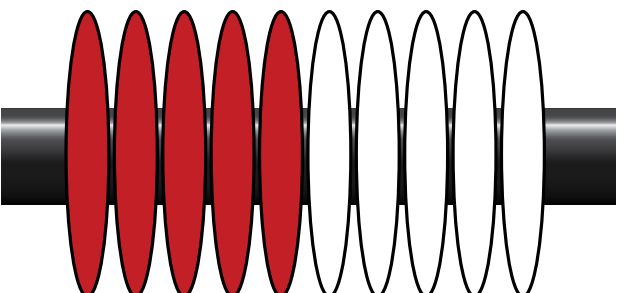
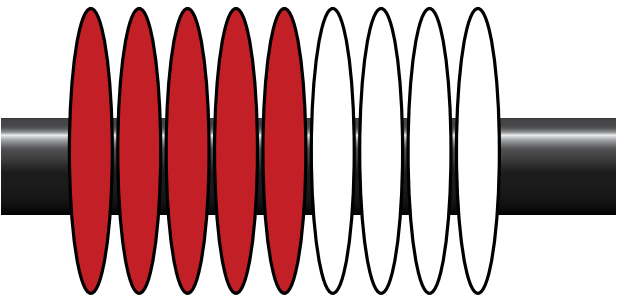
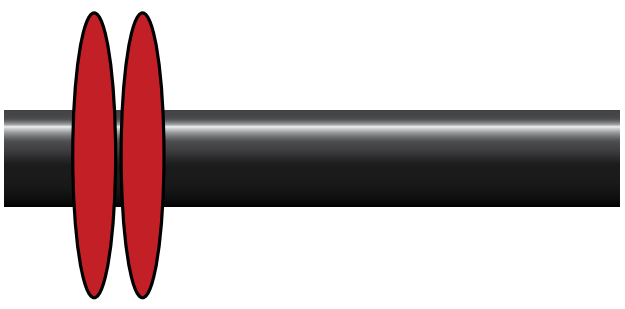
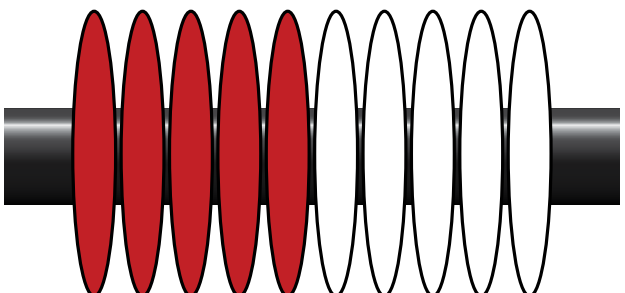
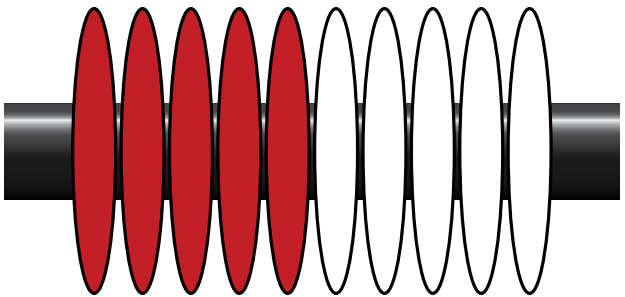

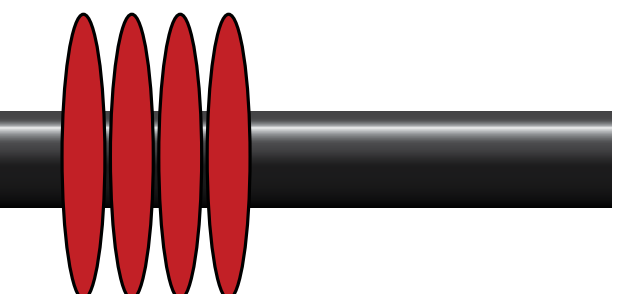
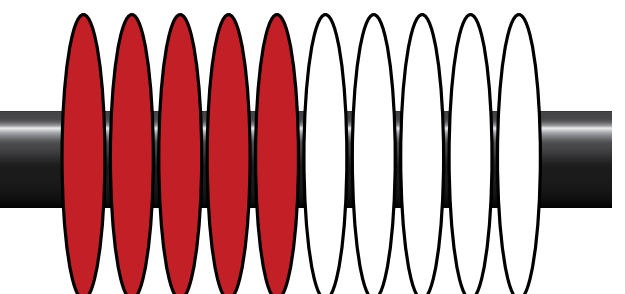
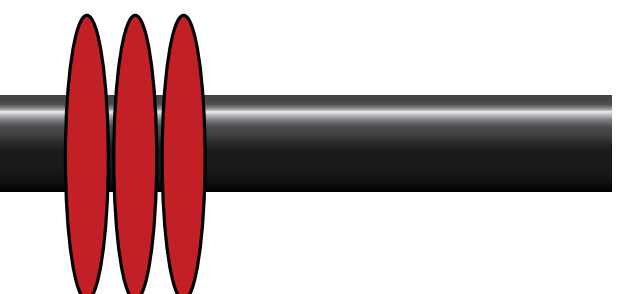
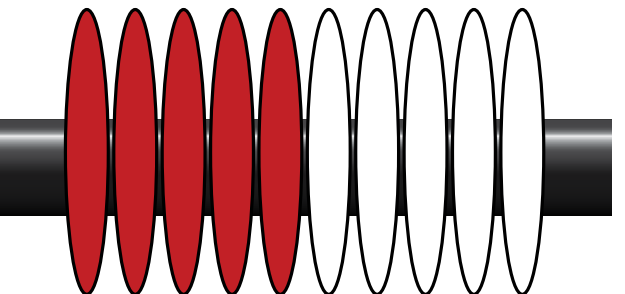
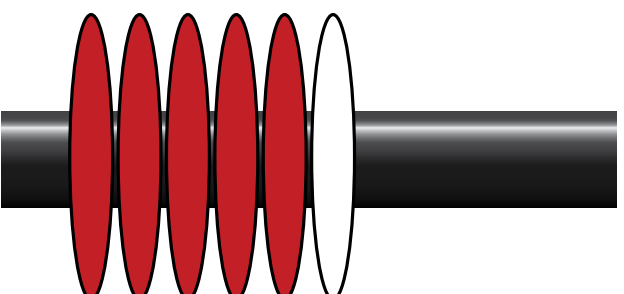
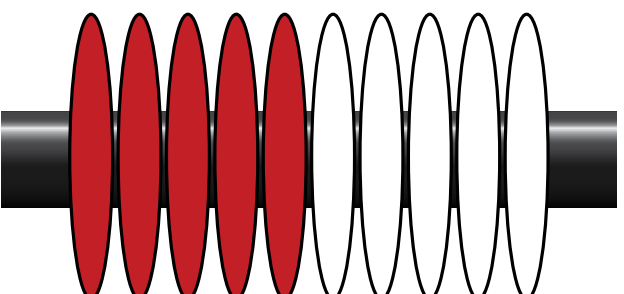
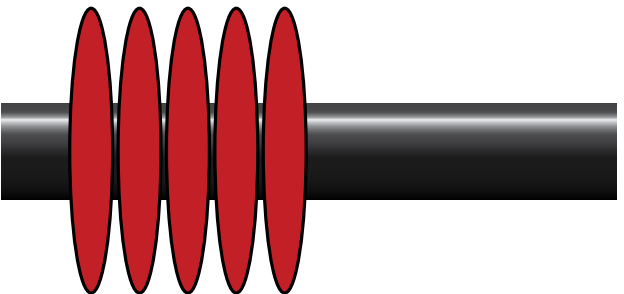
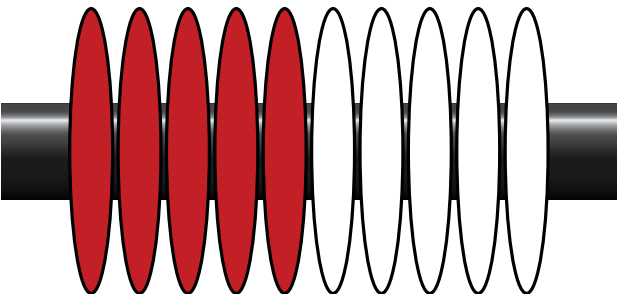

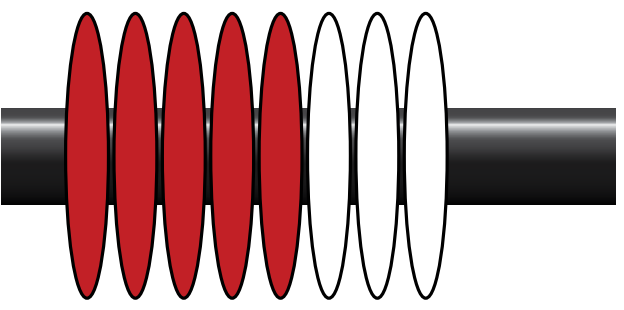
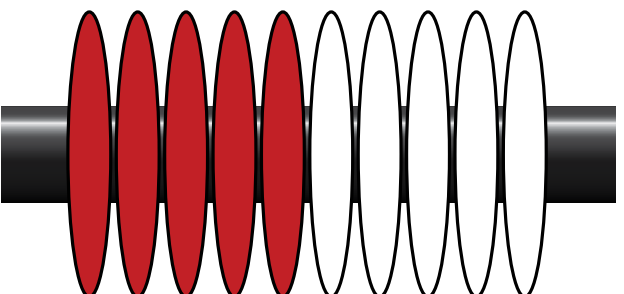
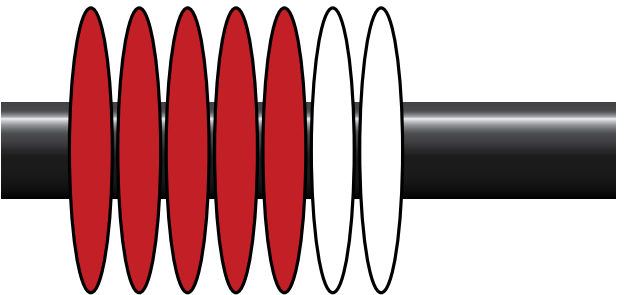
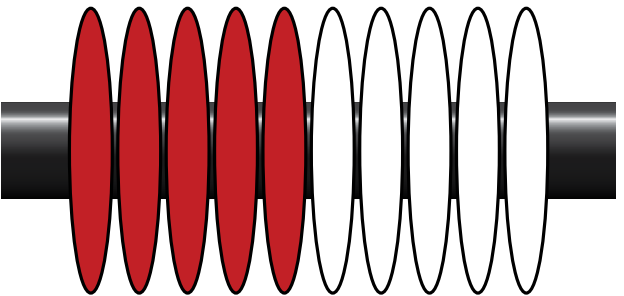
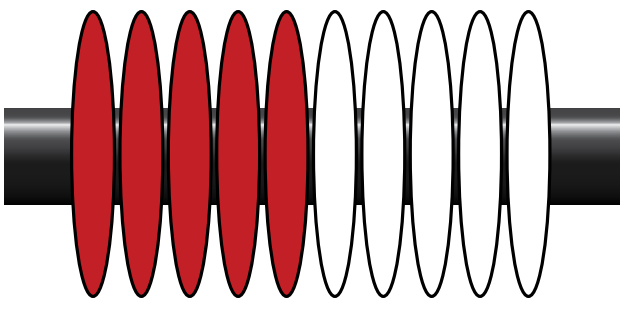
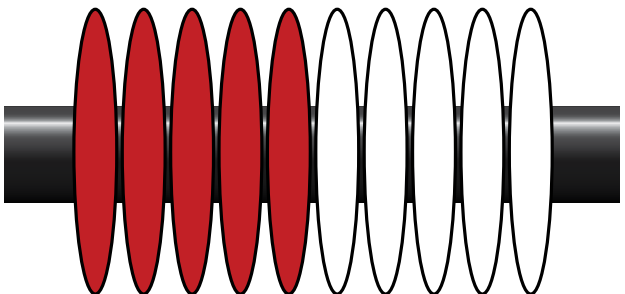
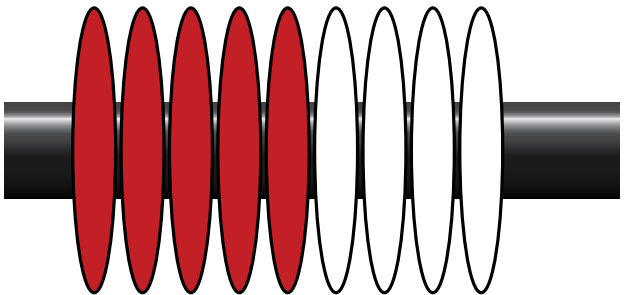
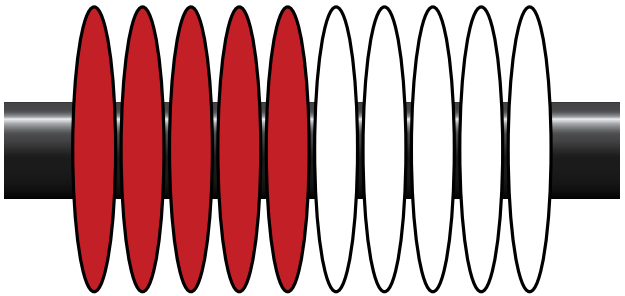



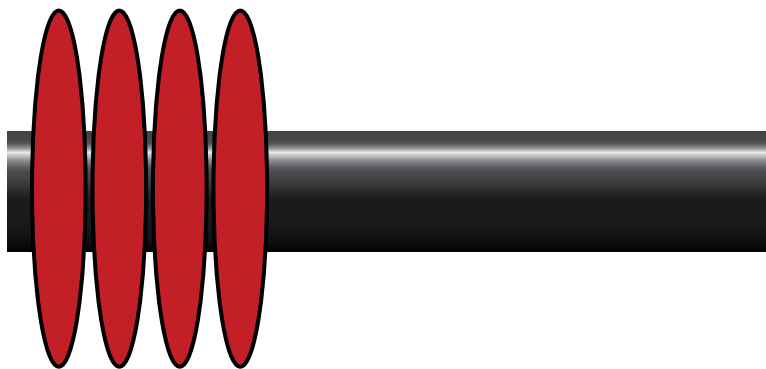
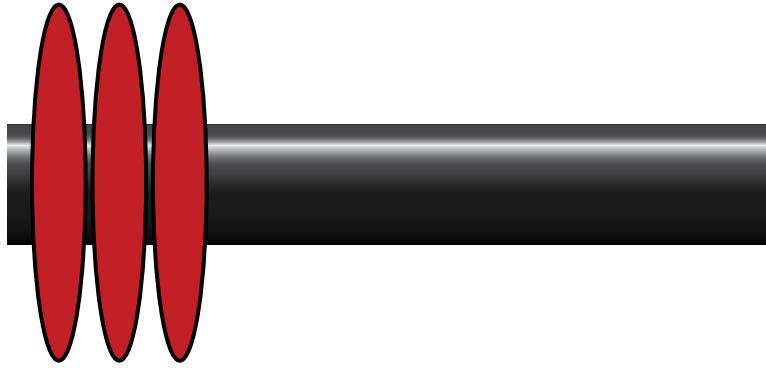



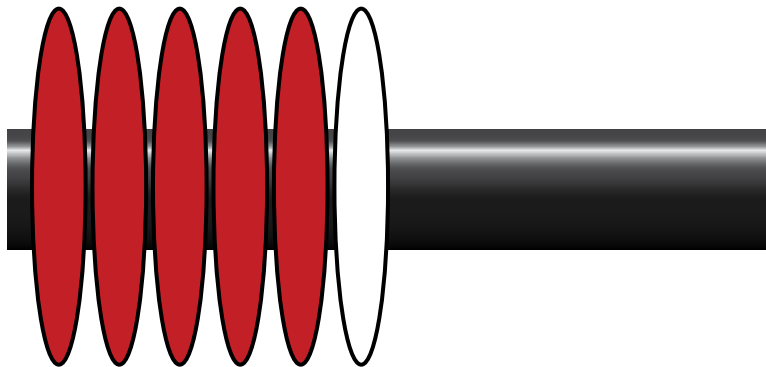
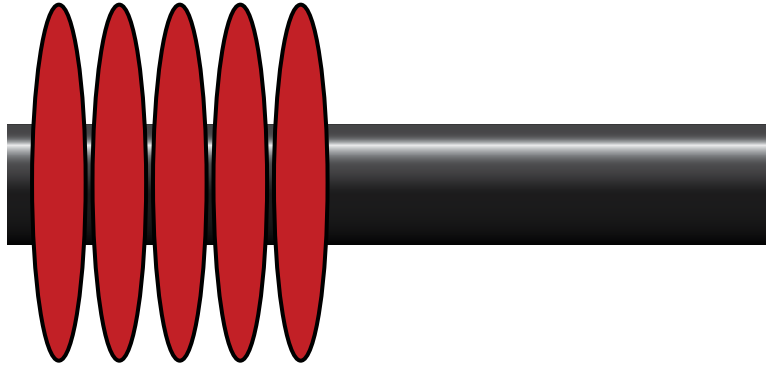

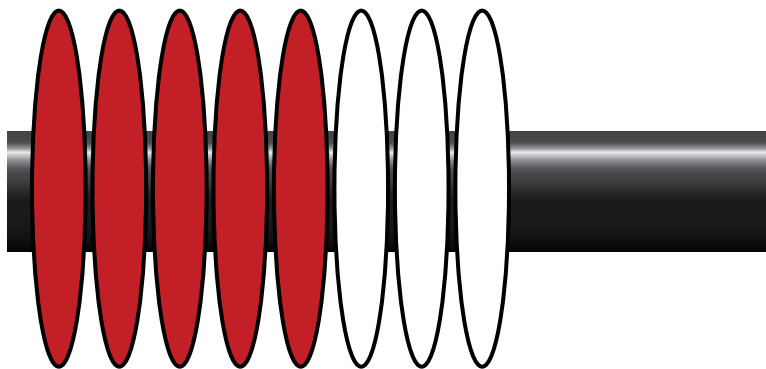
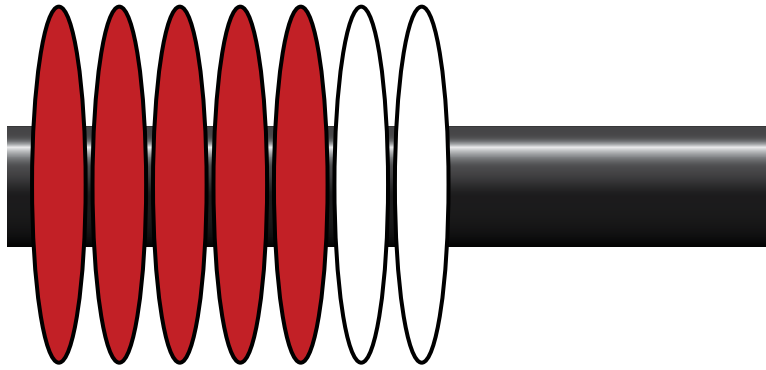

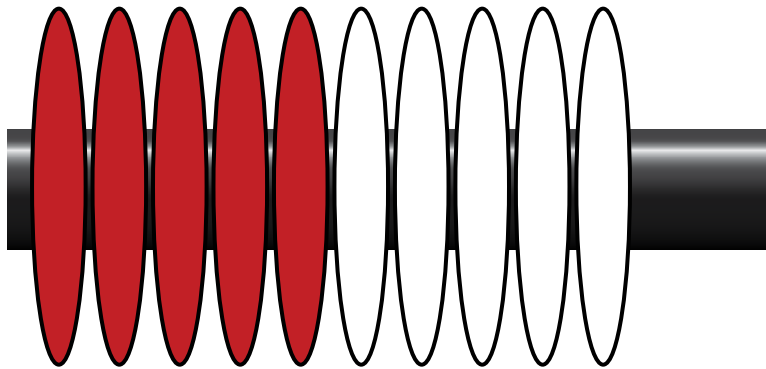
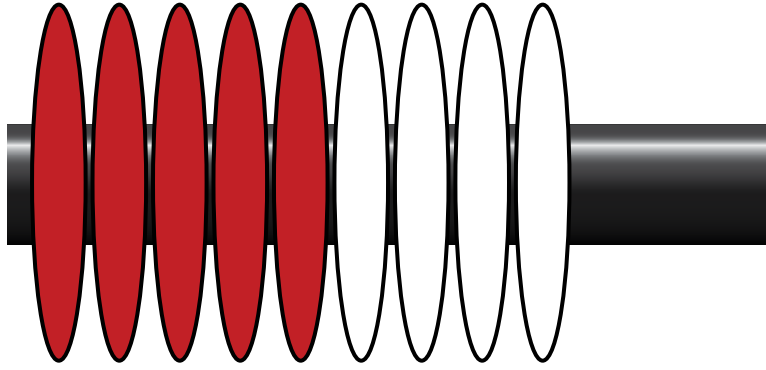

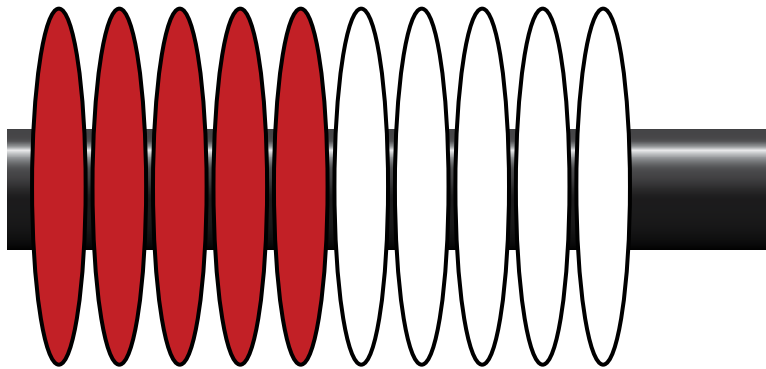
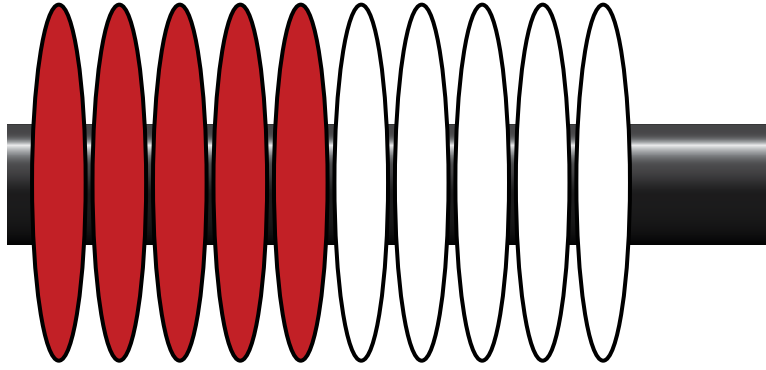

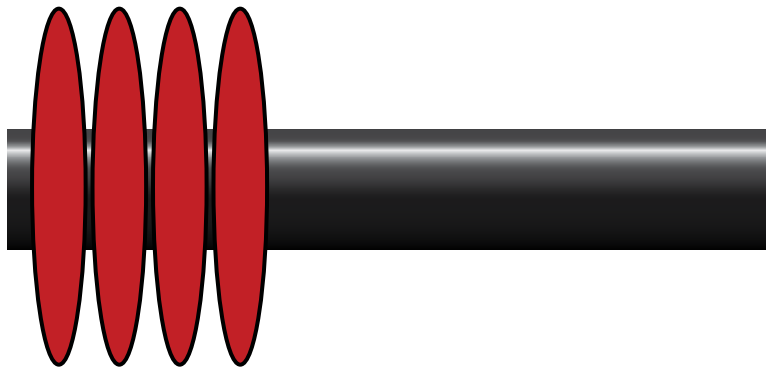
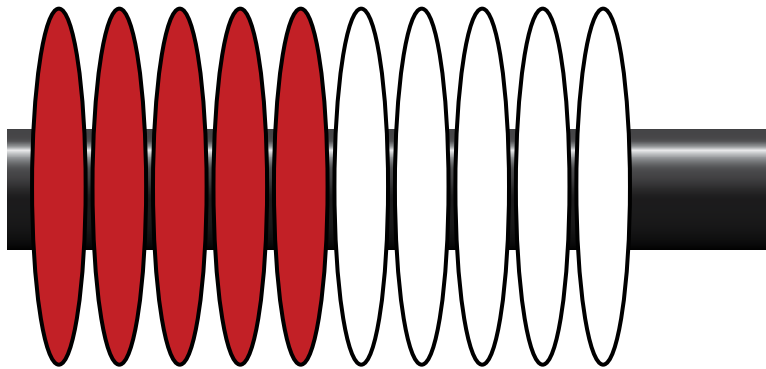
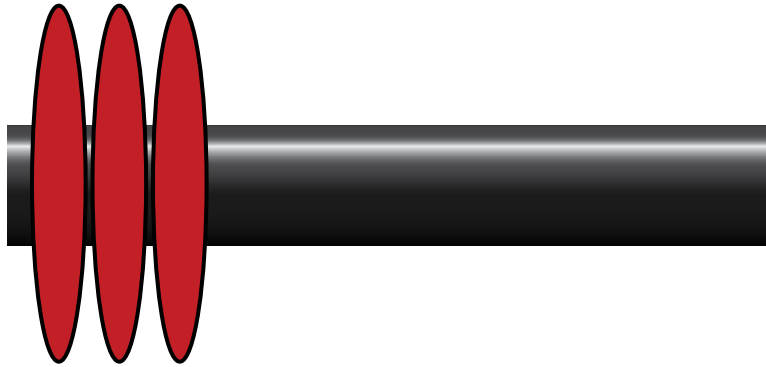
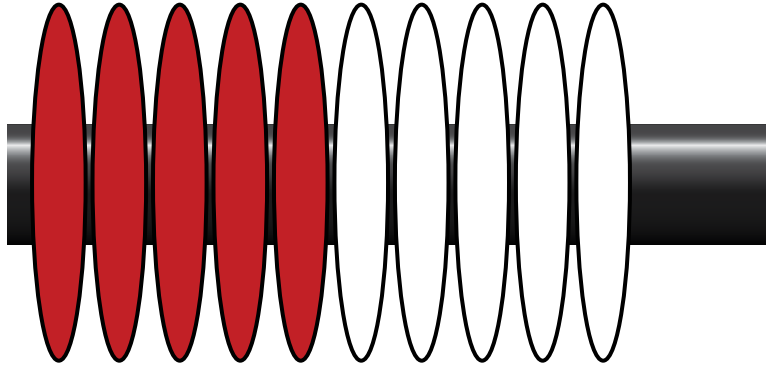

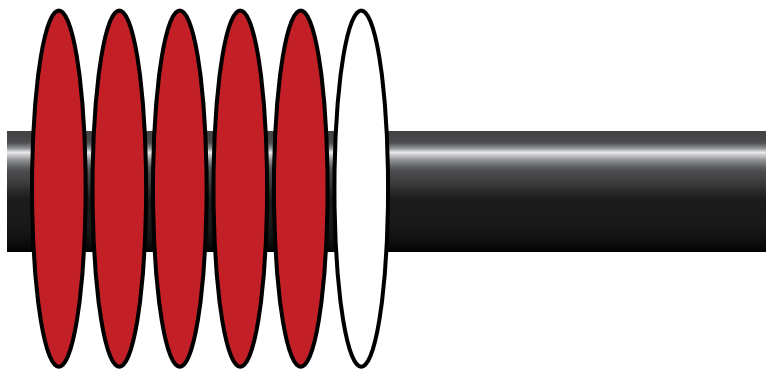
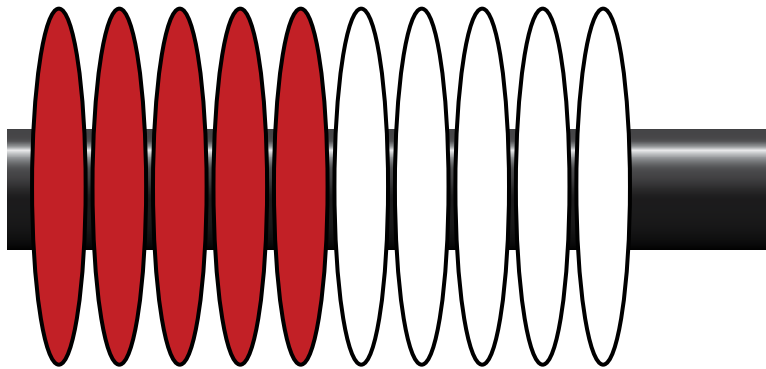
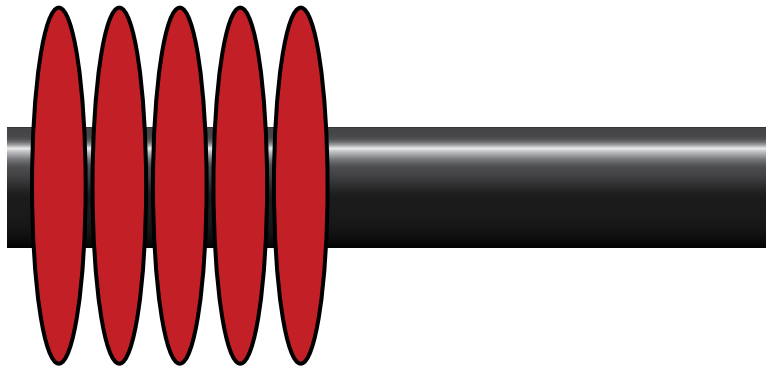
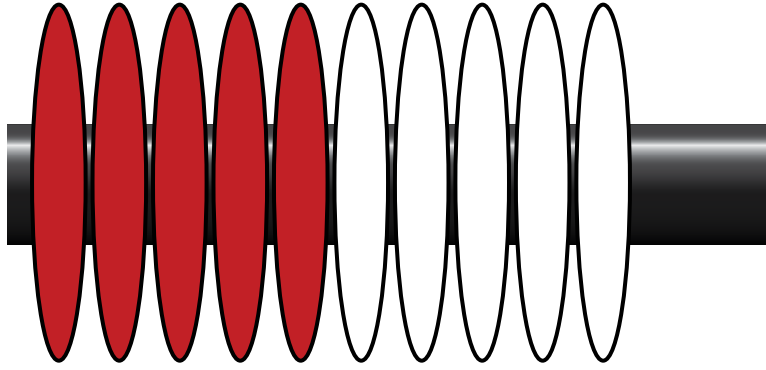

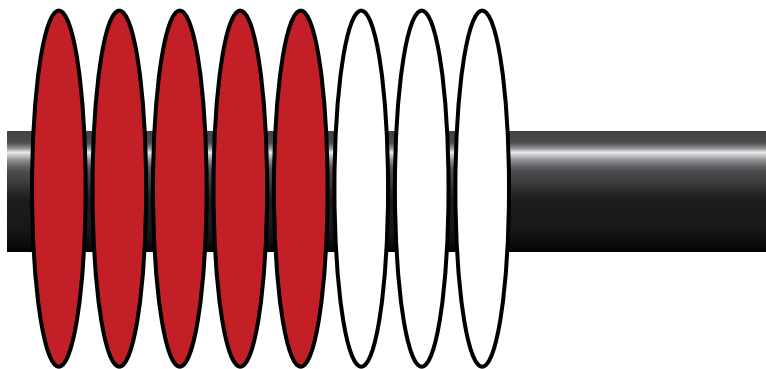
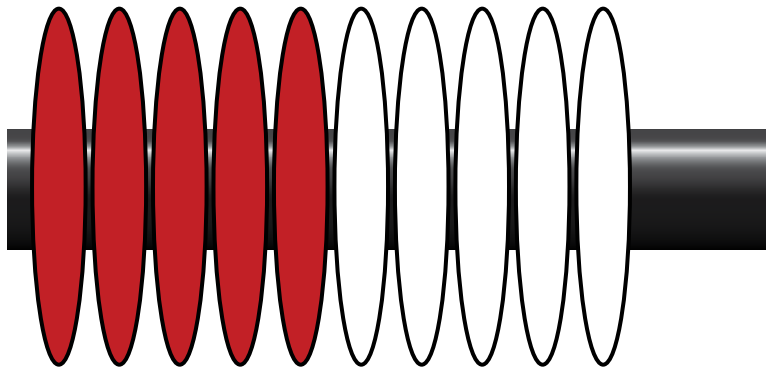
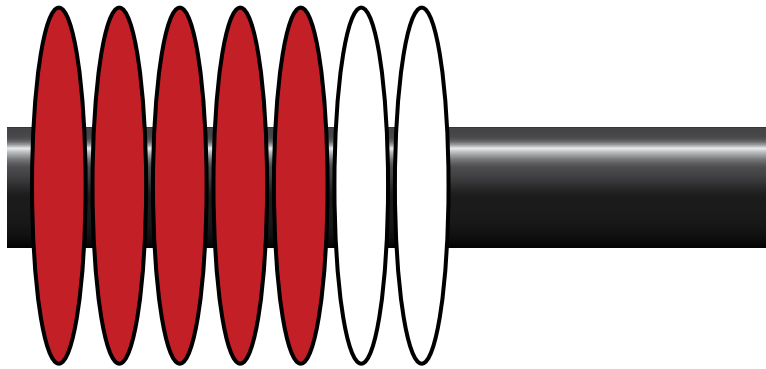
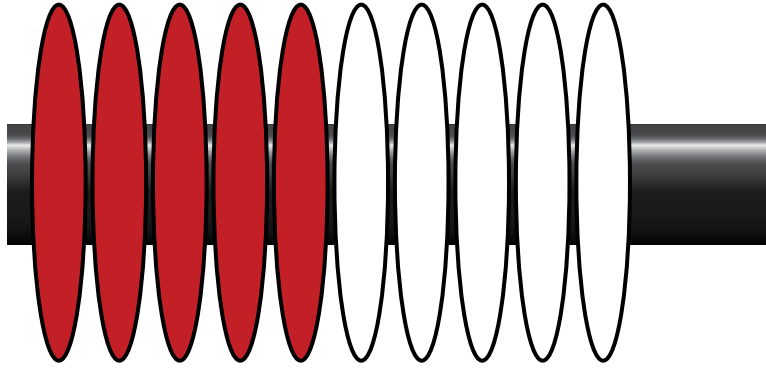

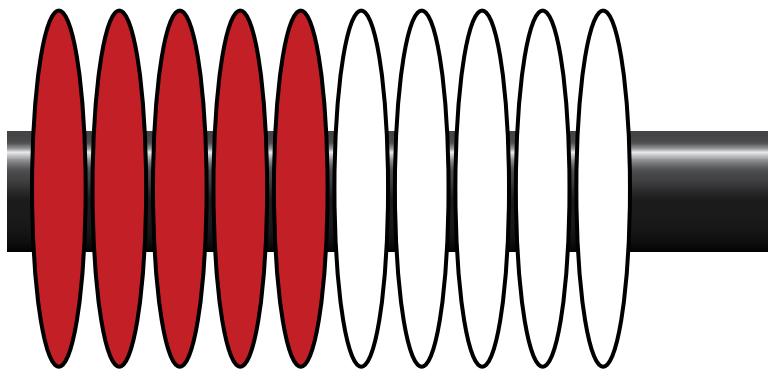
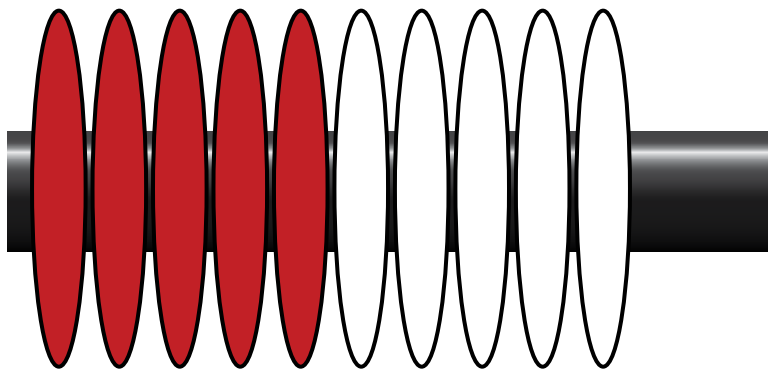
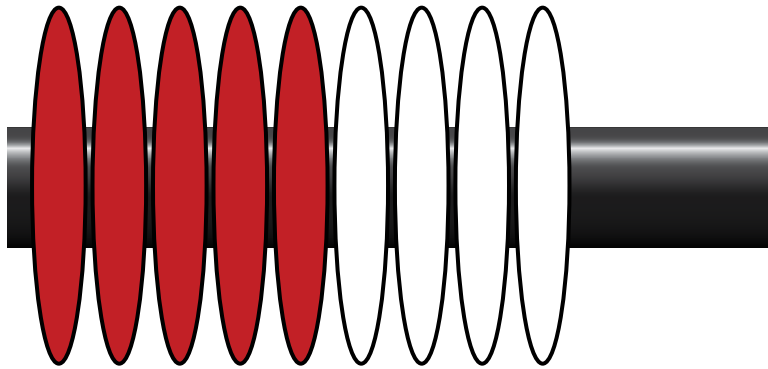
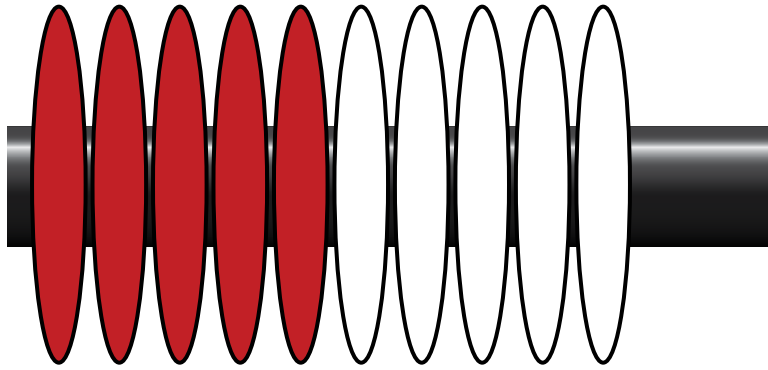





●	●	●		

●	●	●	●	



●				

●	●			





●	●	●	●	●
●	●			

●	●	●	●	●
●	●	●		















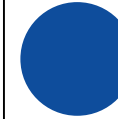



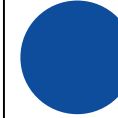



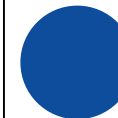

●	●	●	●	●

●	●	●	●	●
●				



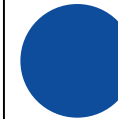











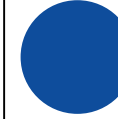





				
				
				



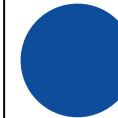



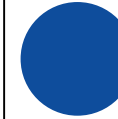

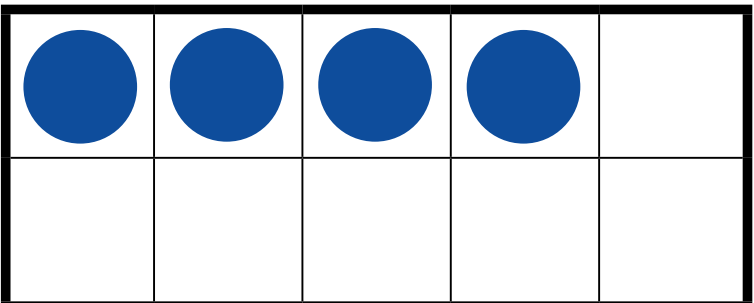
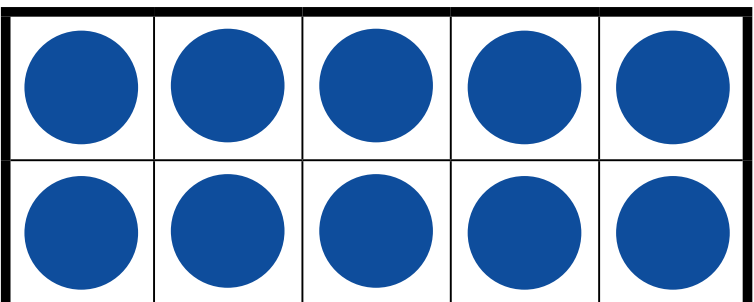
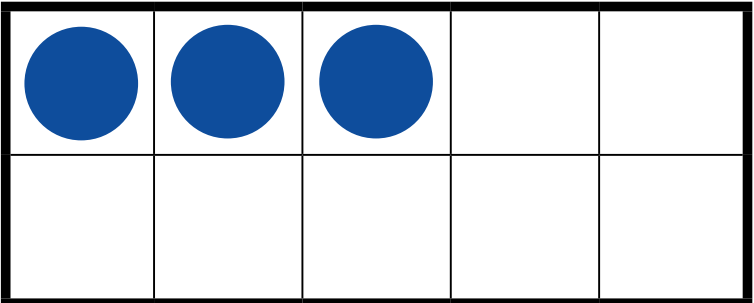
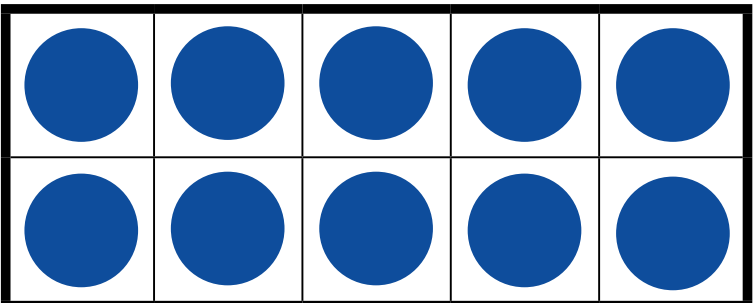
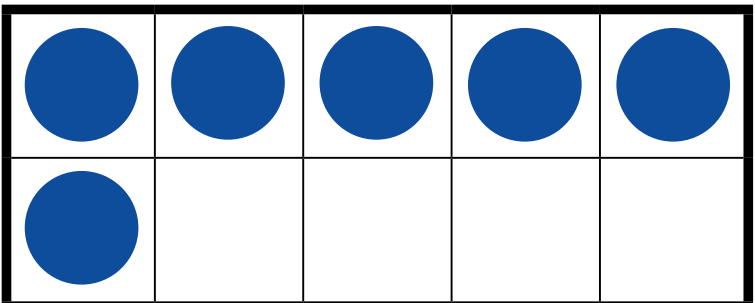
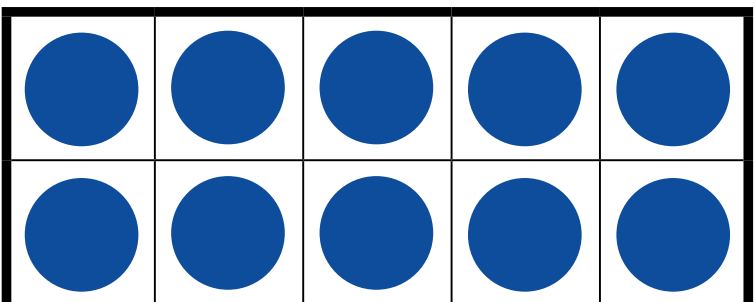
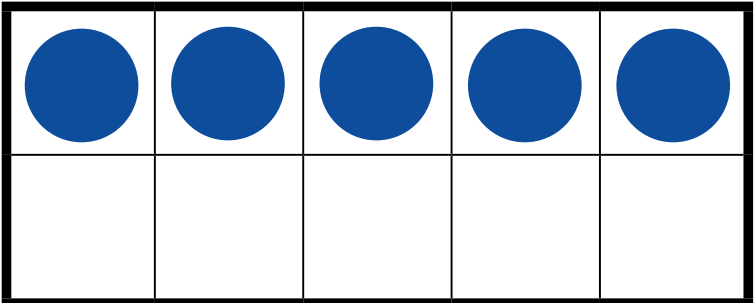
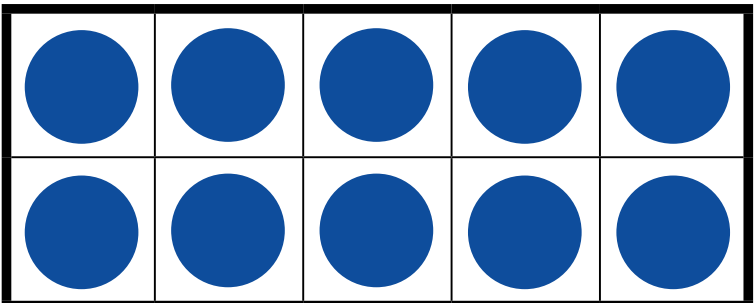

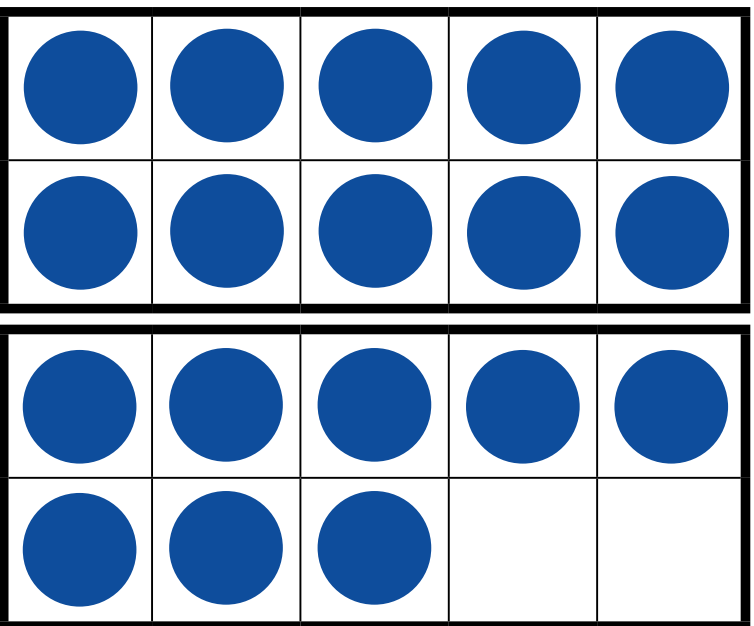
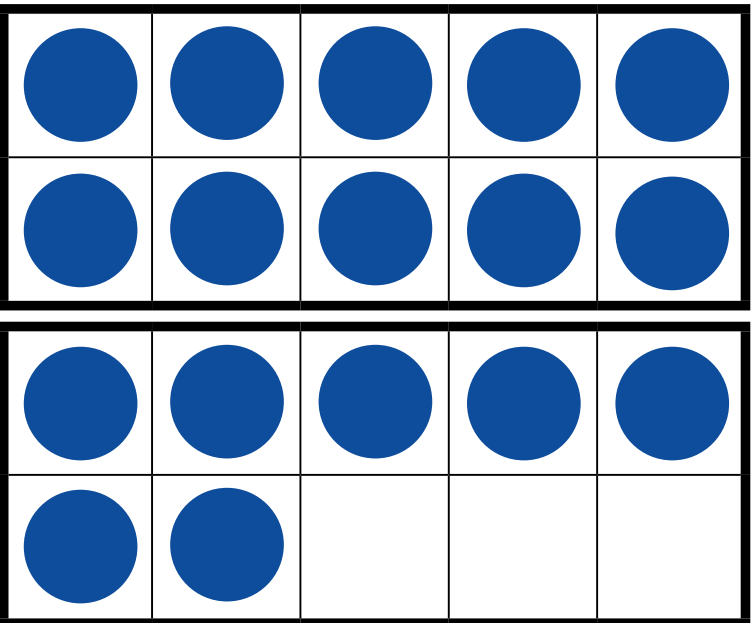
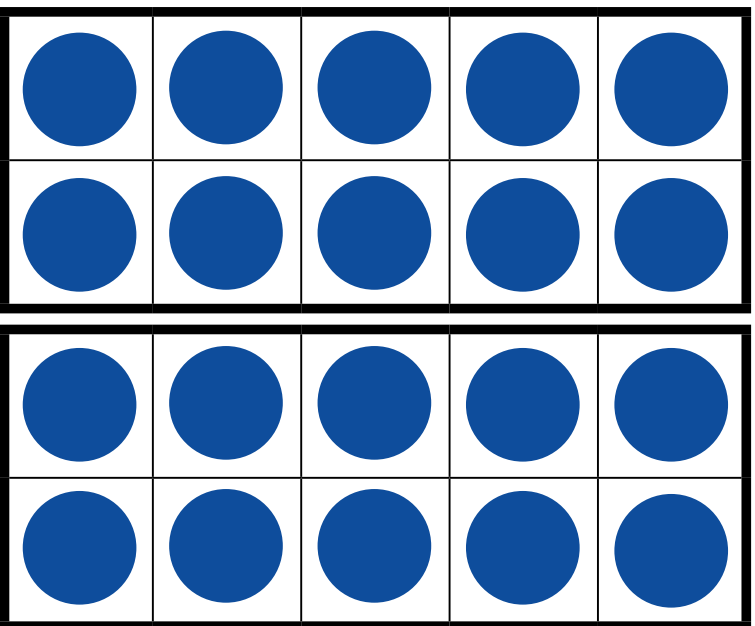
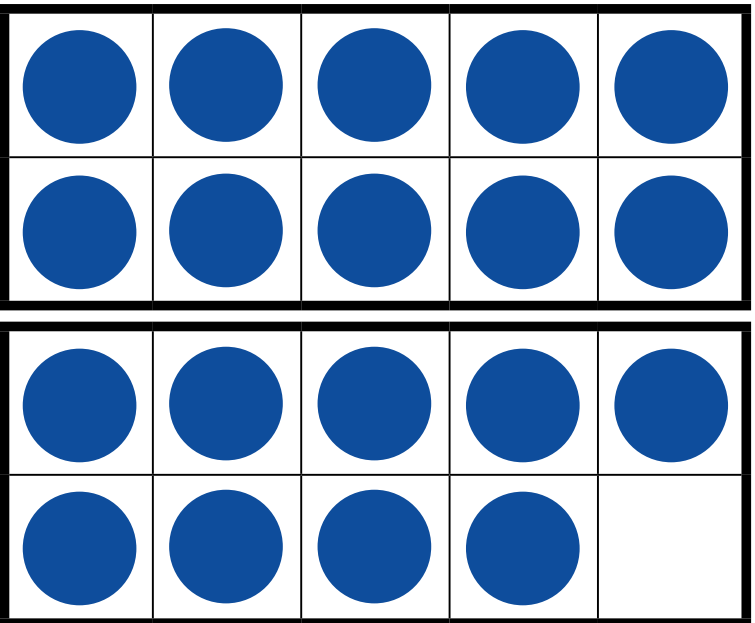

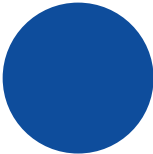

				





				

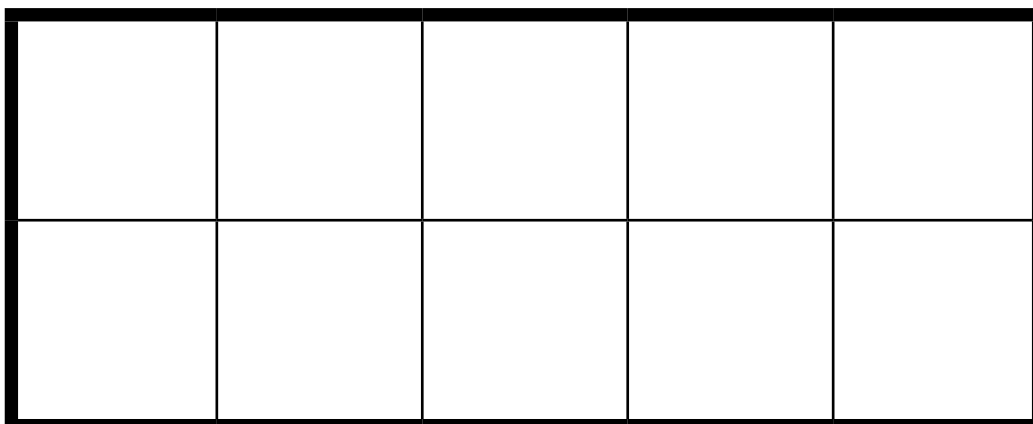
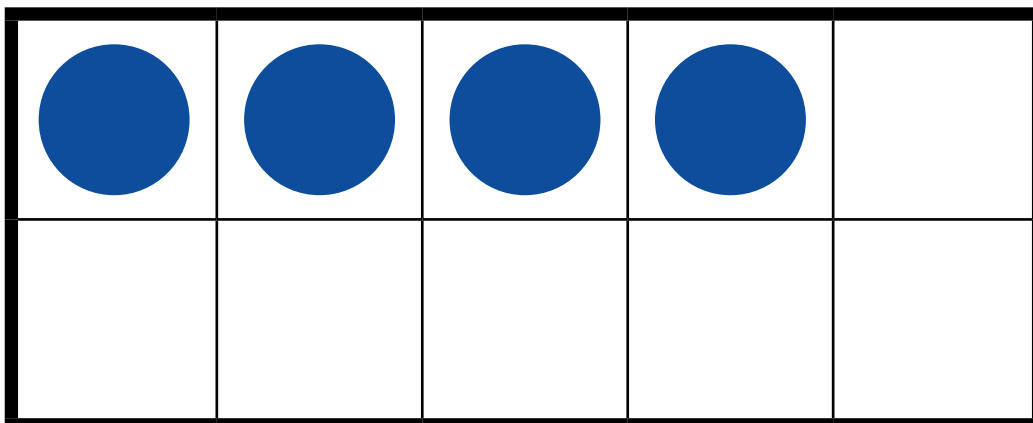
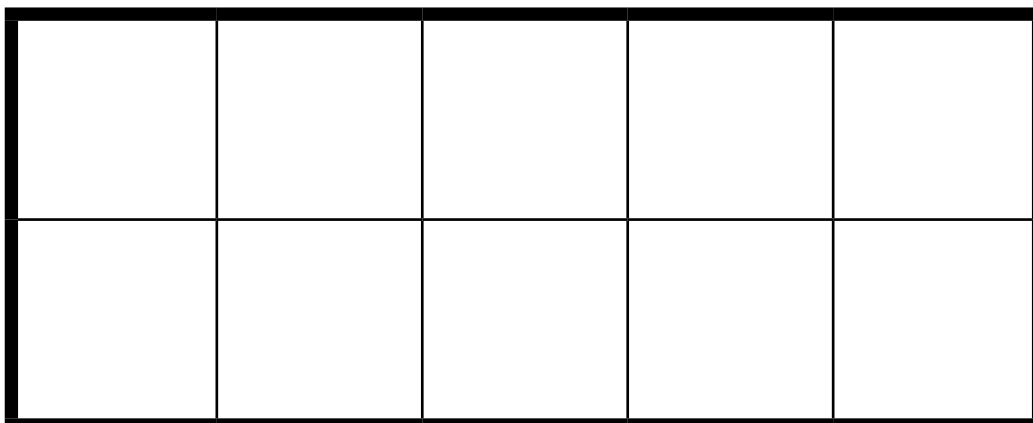
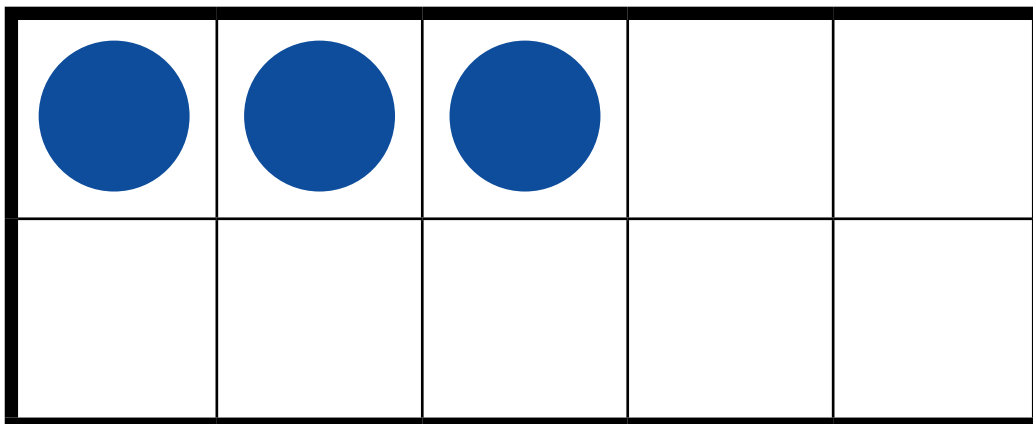

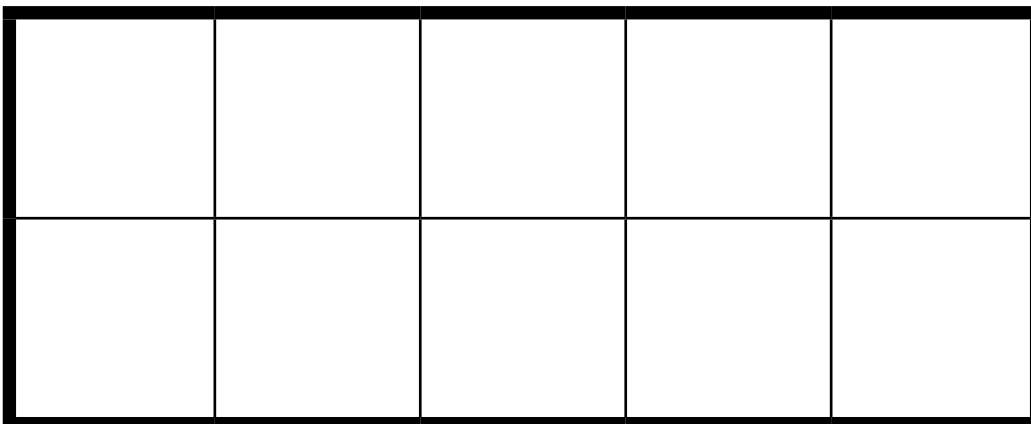
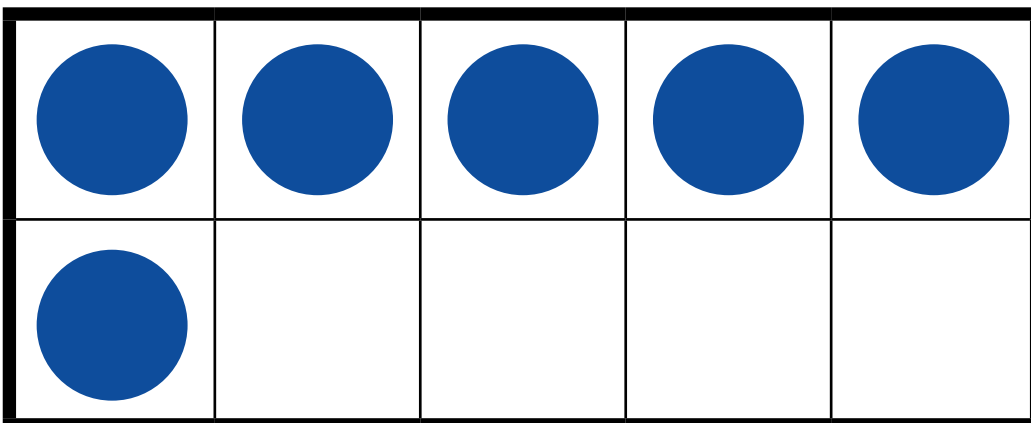
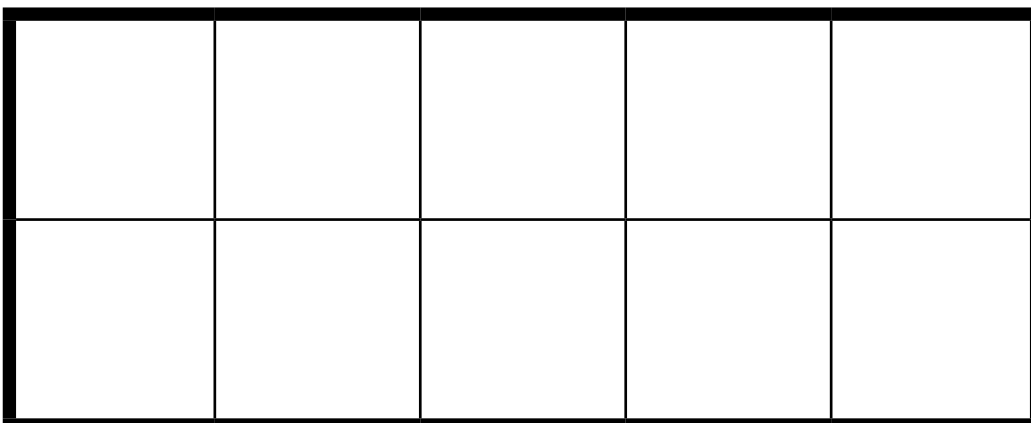
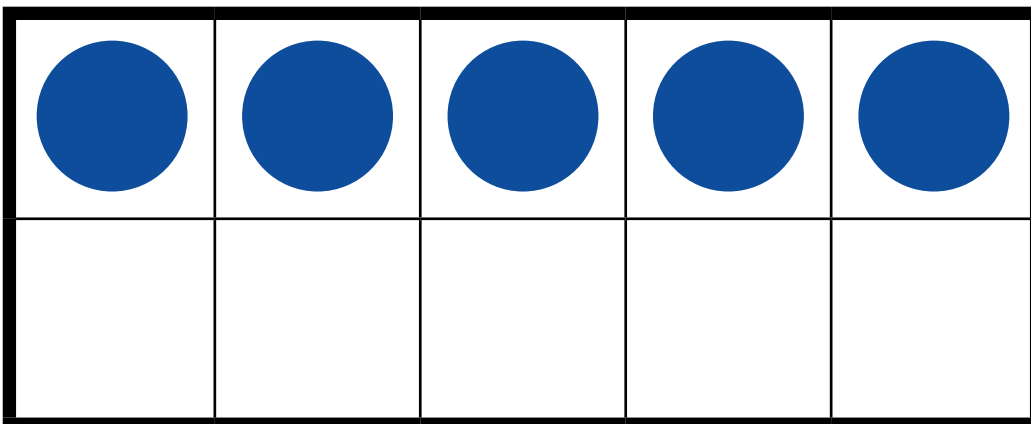



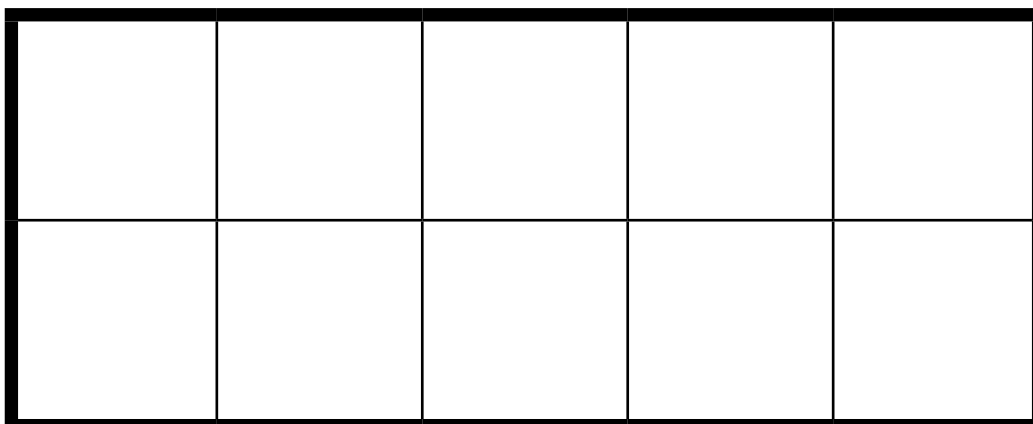
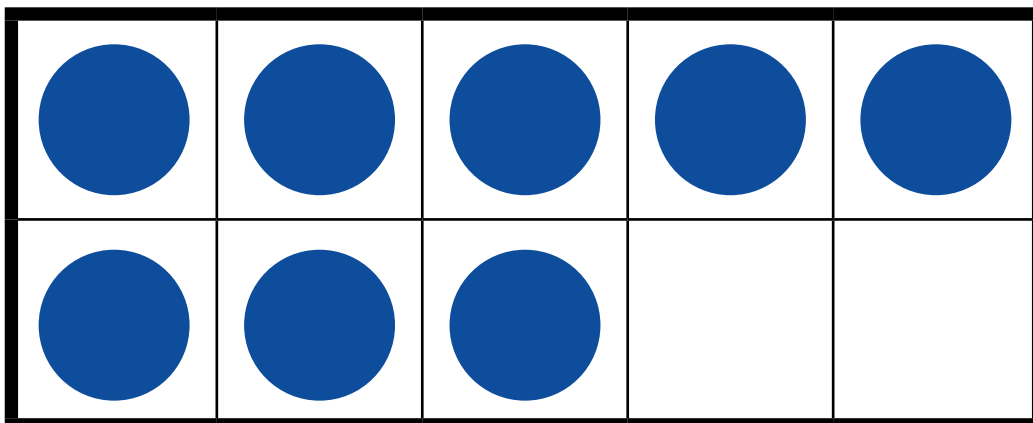
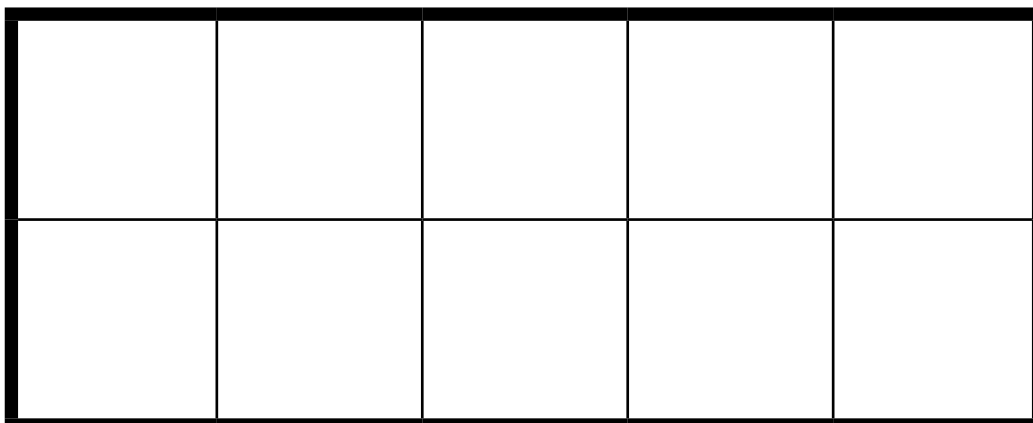
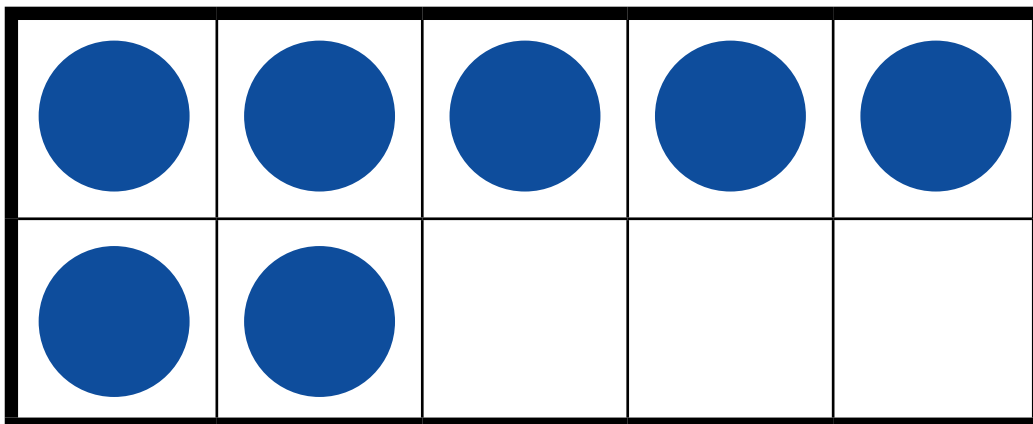



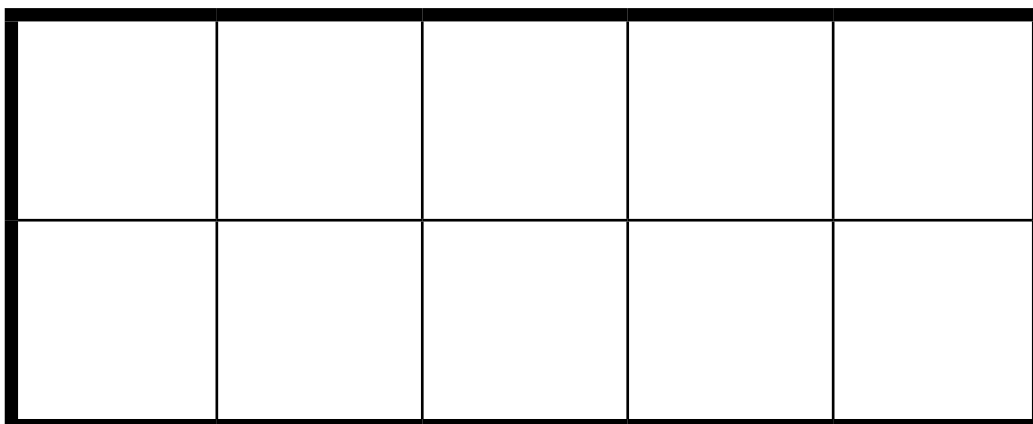
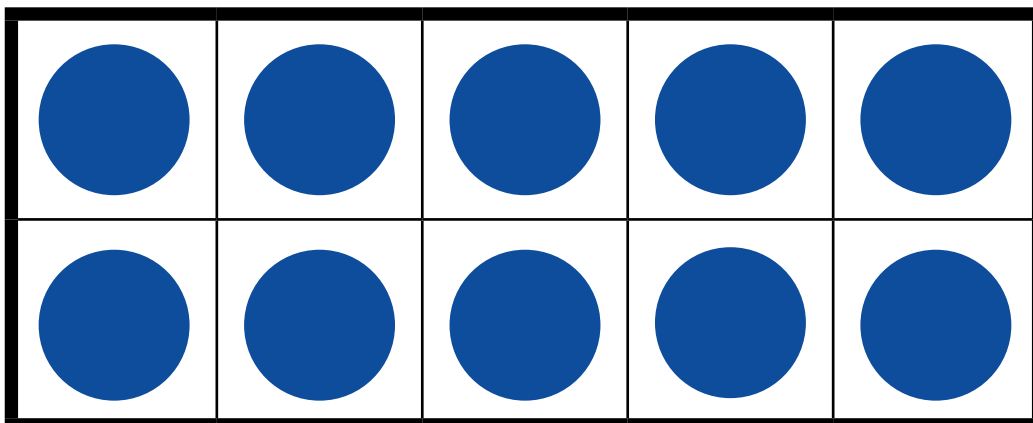
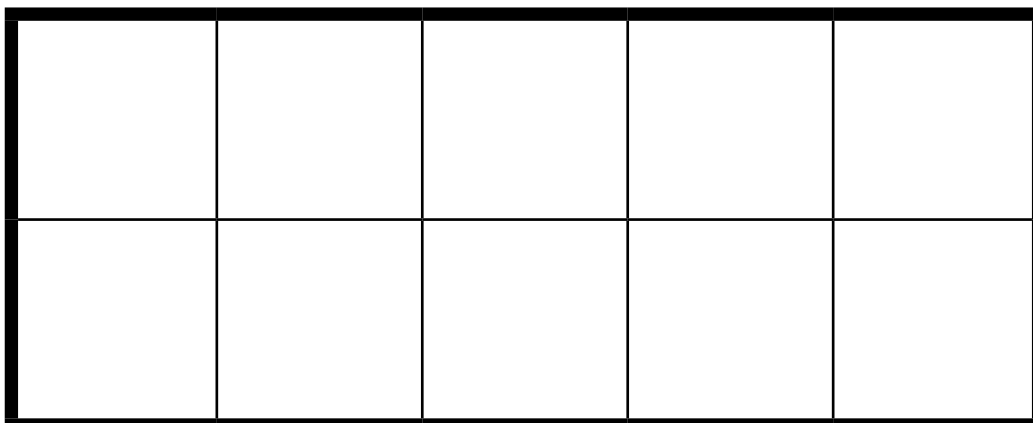
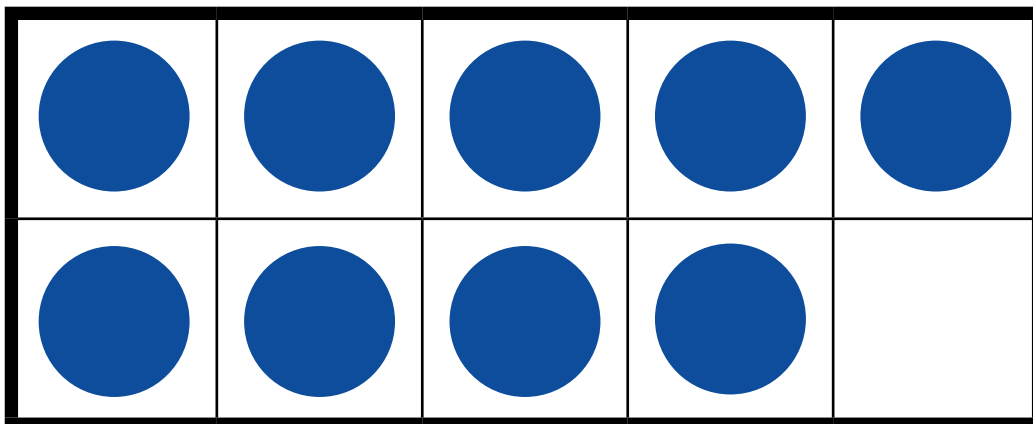

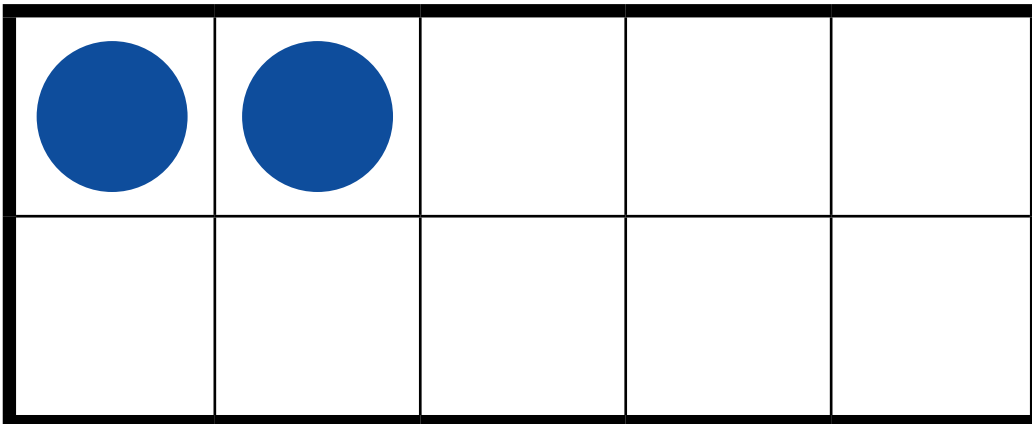
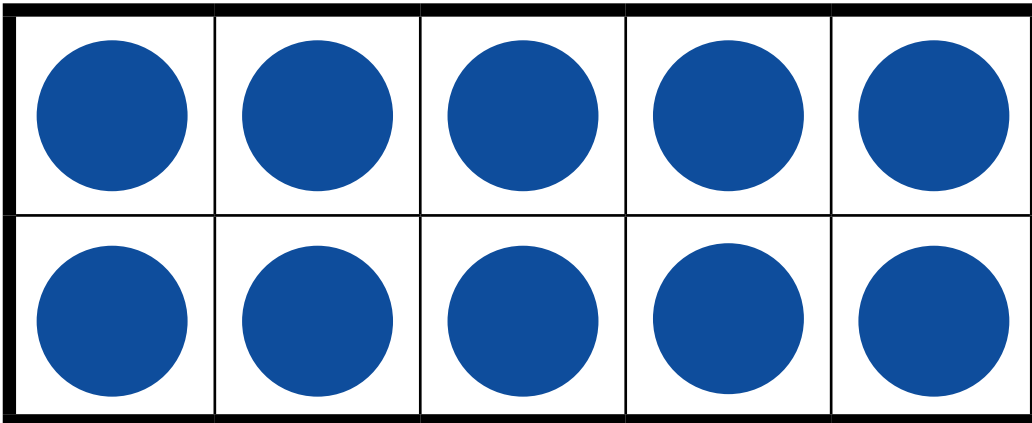
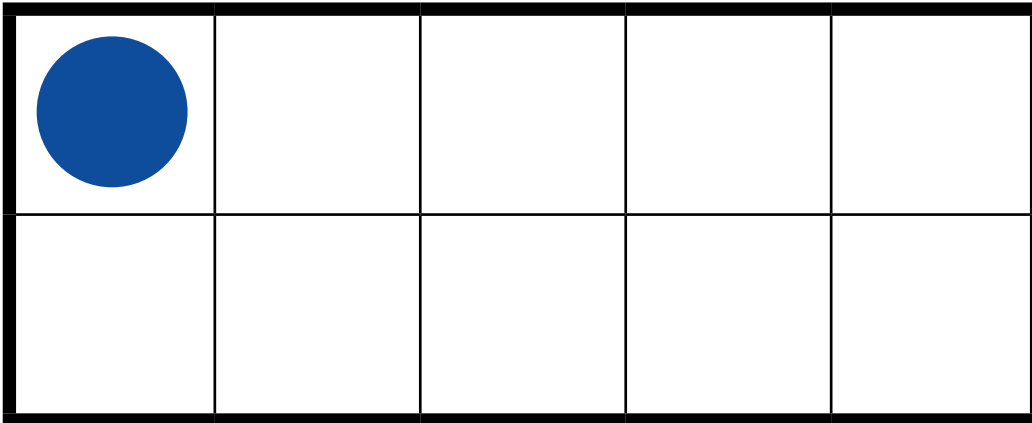
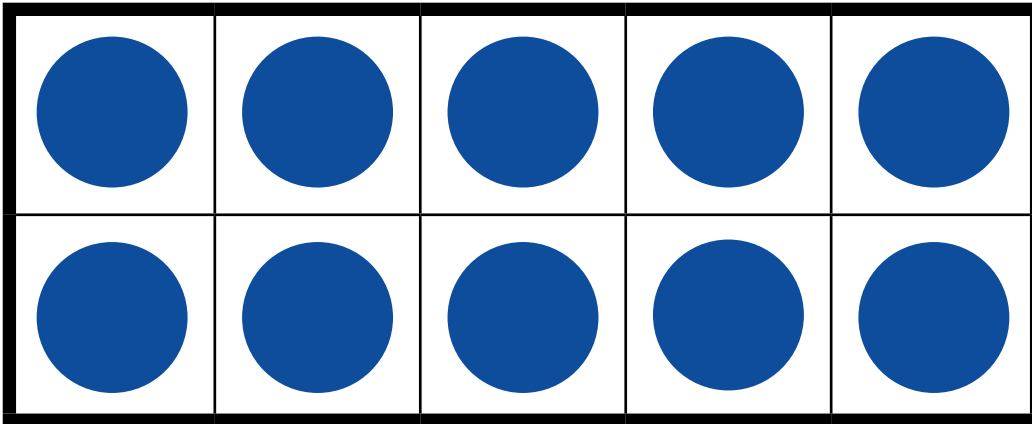



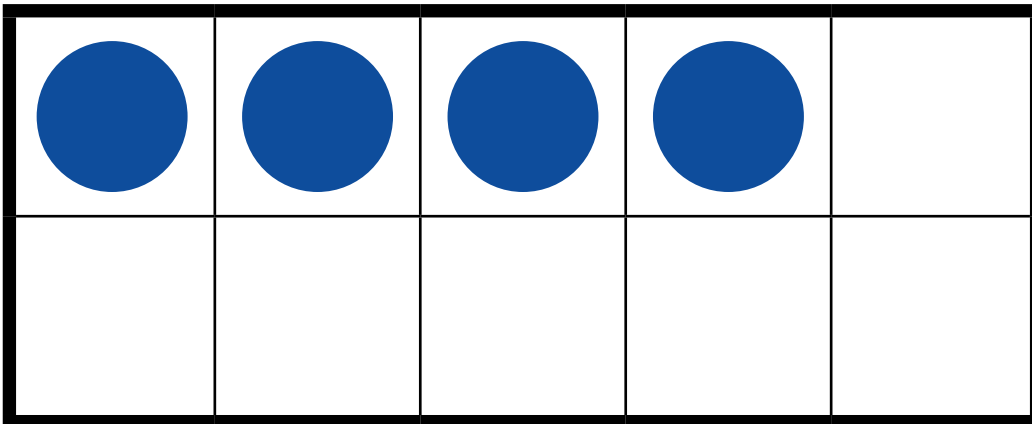
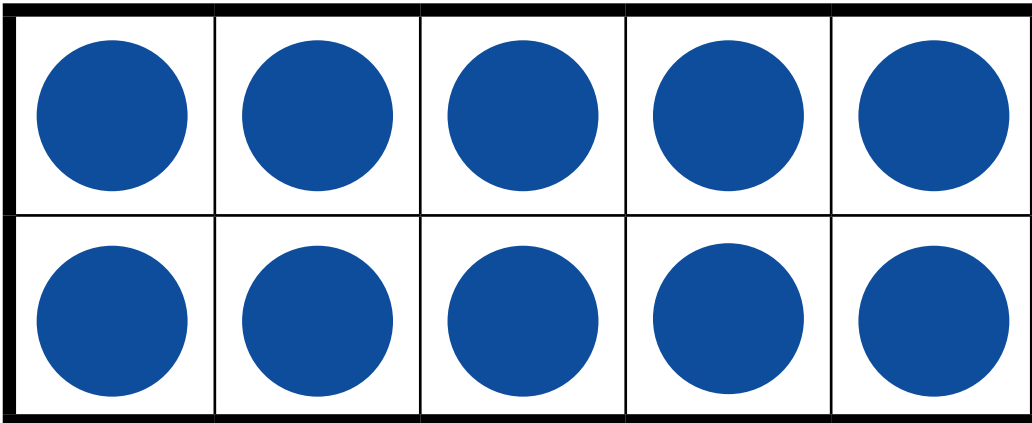
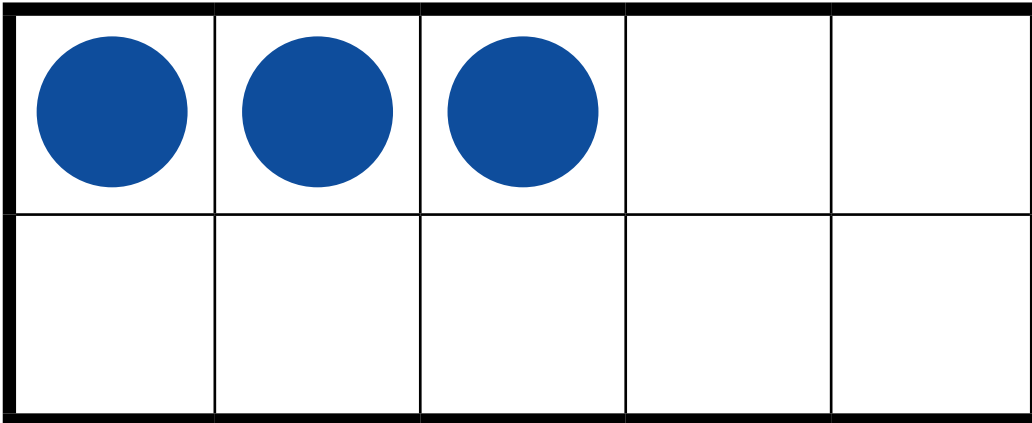
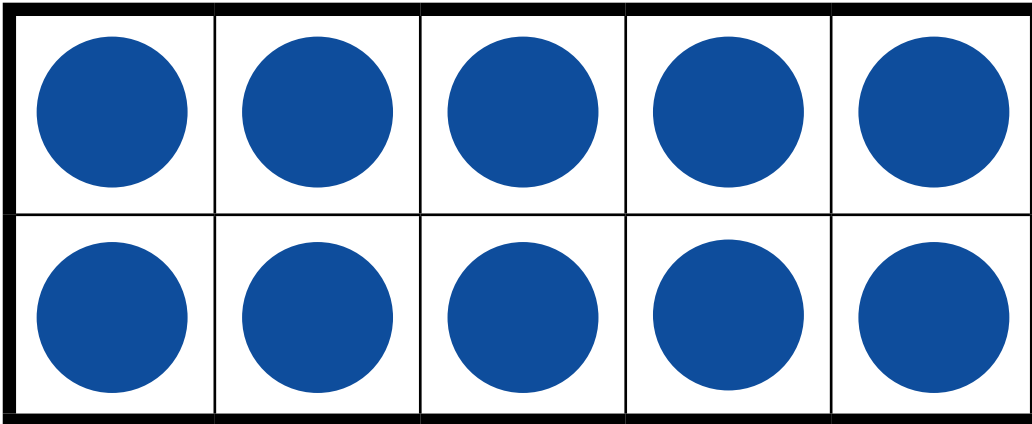

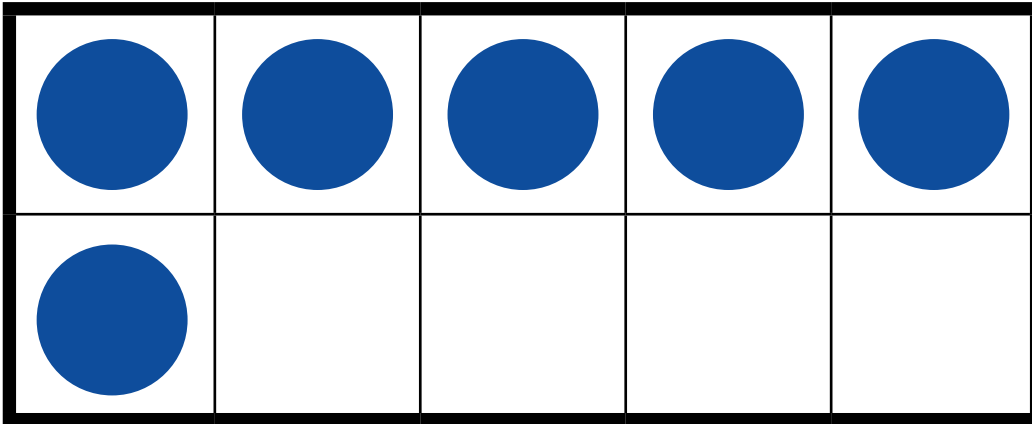
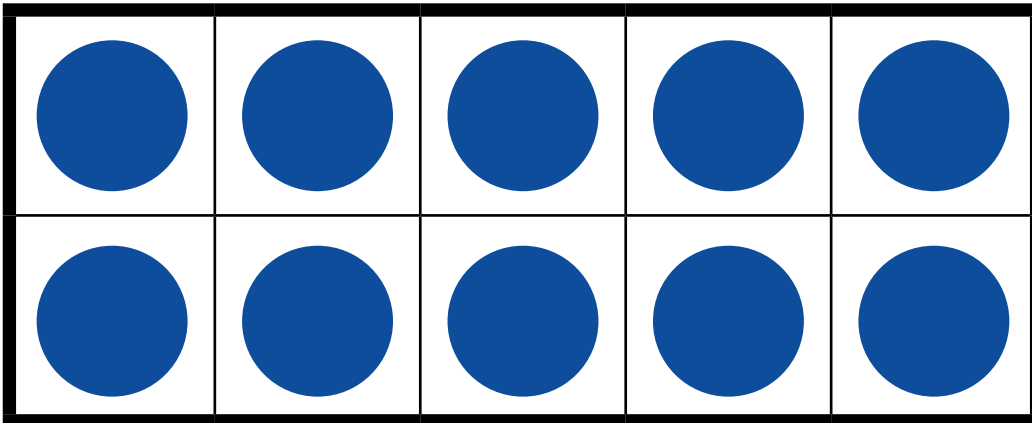
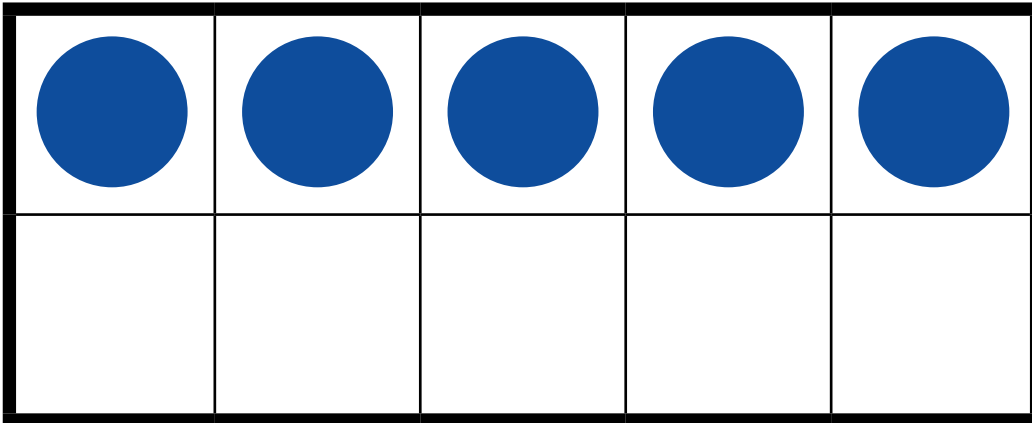
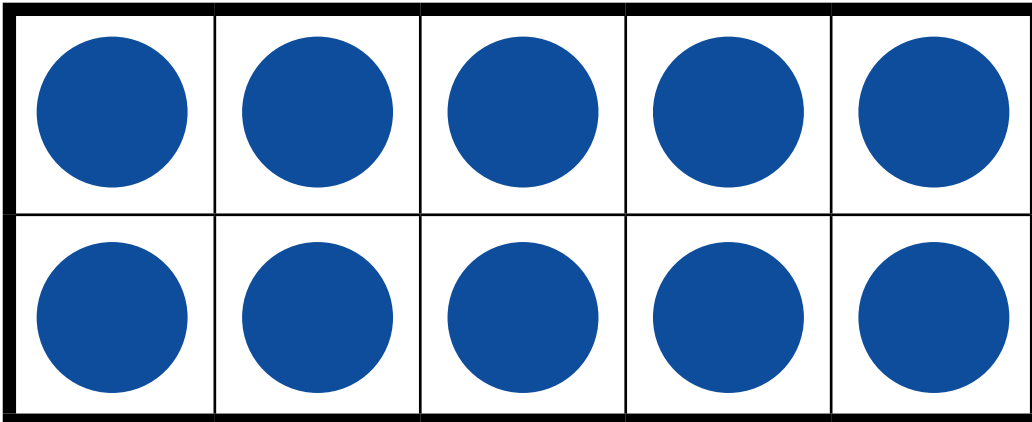

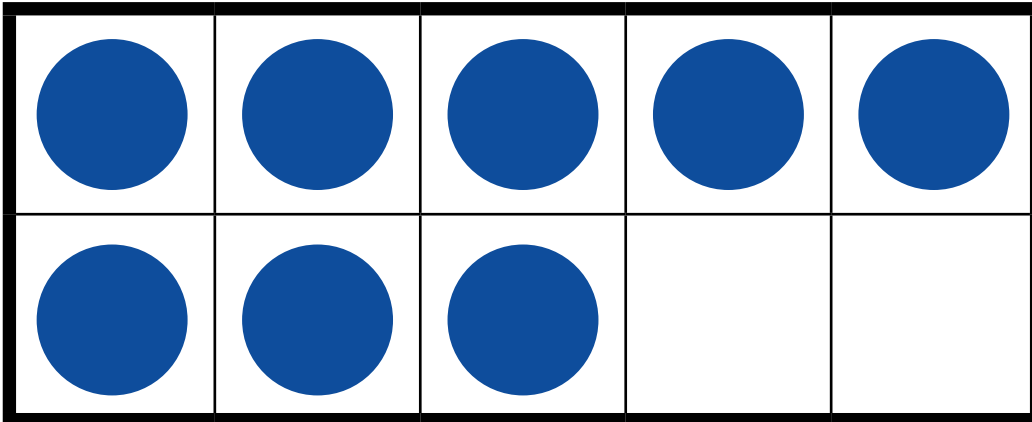
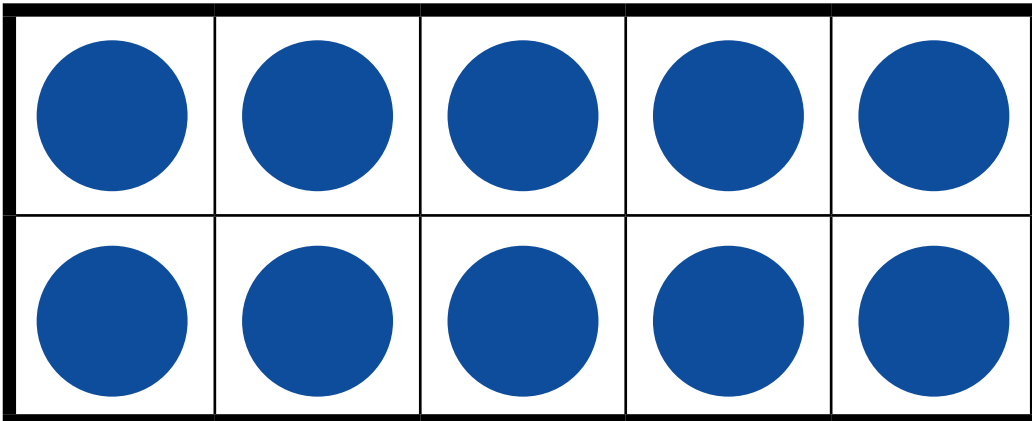
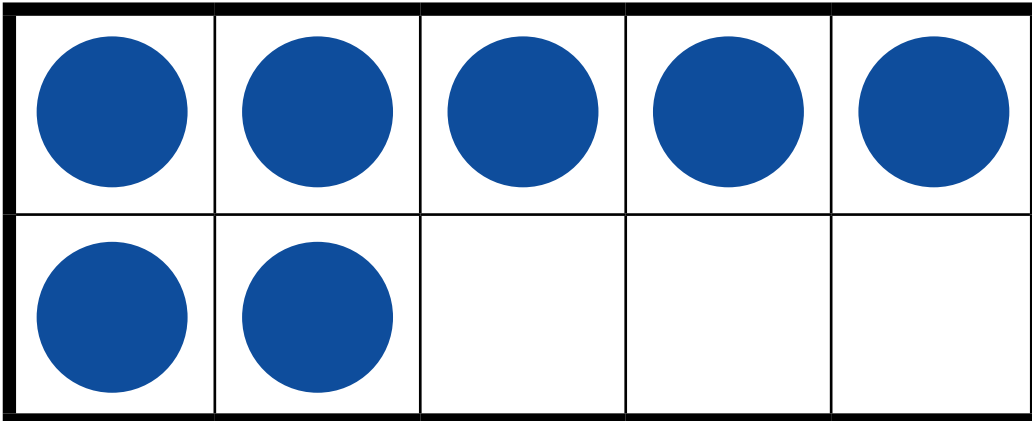
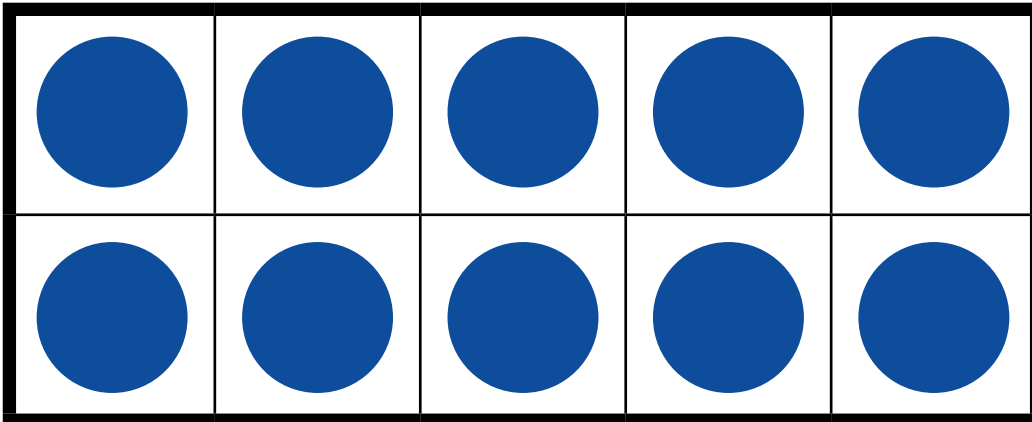

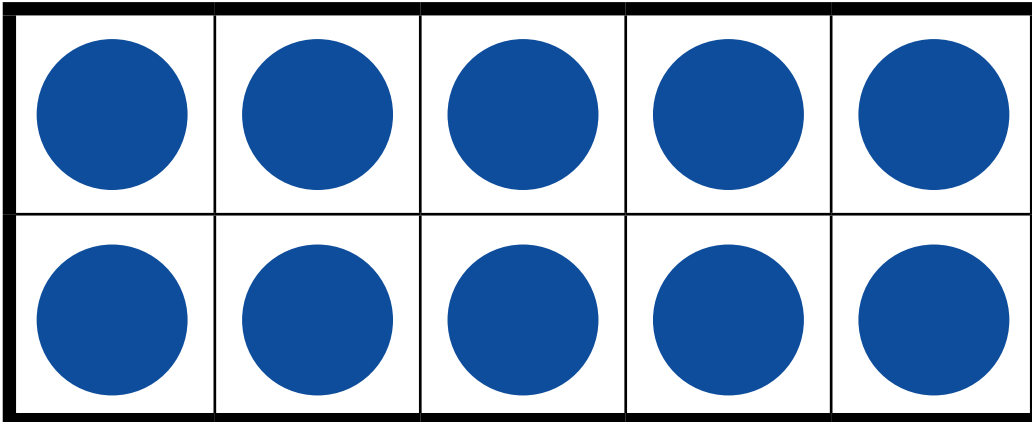
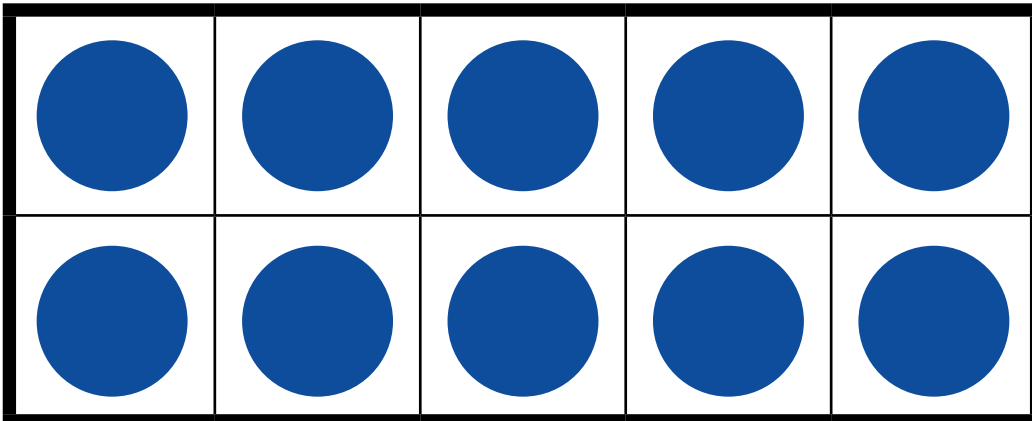
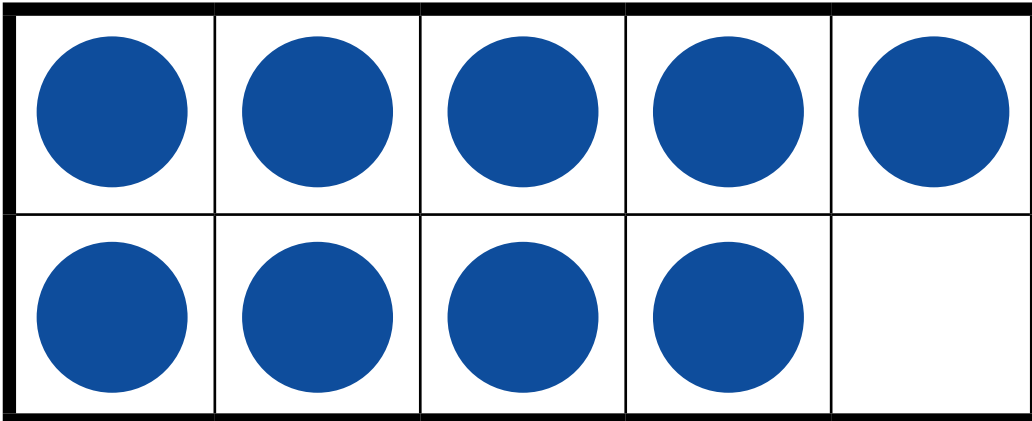
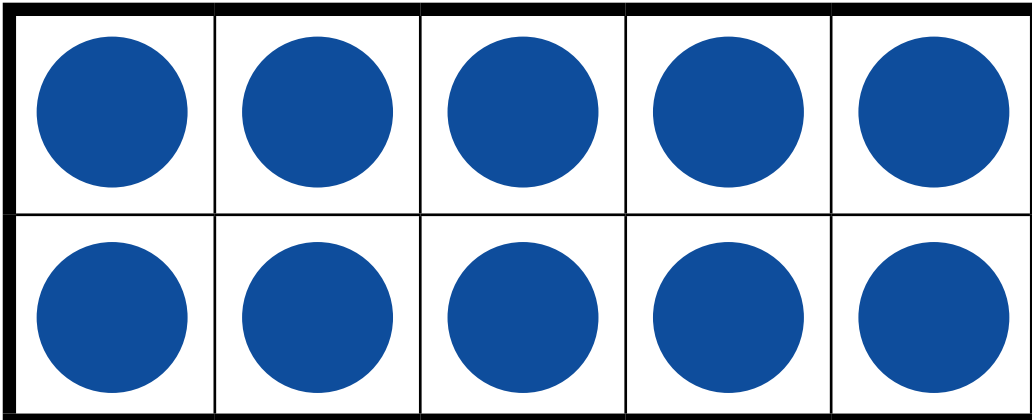

Doigts de deux paires de mains (1 à 20)

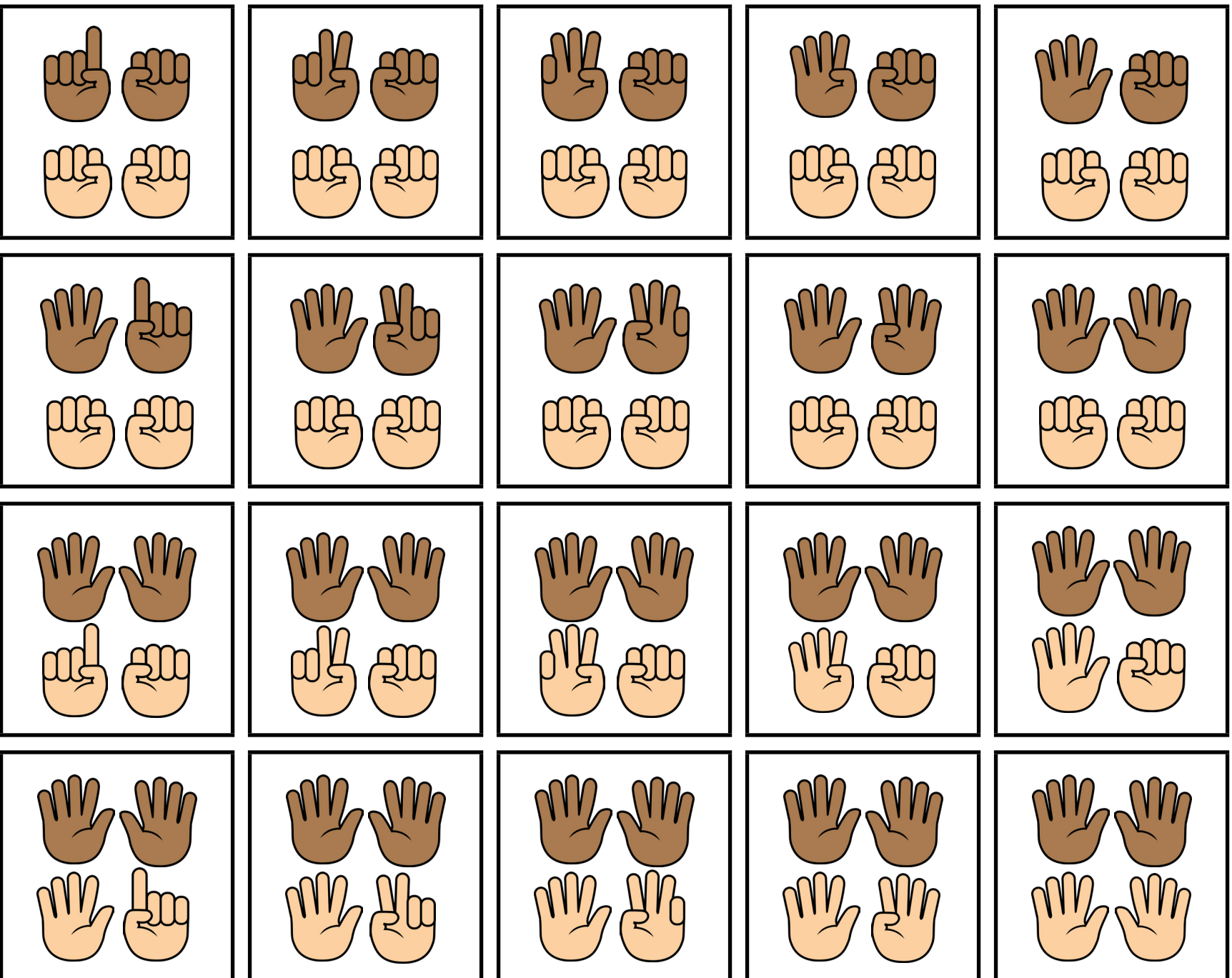



# Cartes de représentations imagée des nombres jusqu'à 20

Doigts (0 à 20) avec nombres

0	
1	
2	
3	
4	
5	
6	
7	
8	
9	
10	
11	
12	
13	
14	
15	
16	
17	
18	
19	
20	



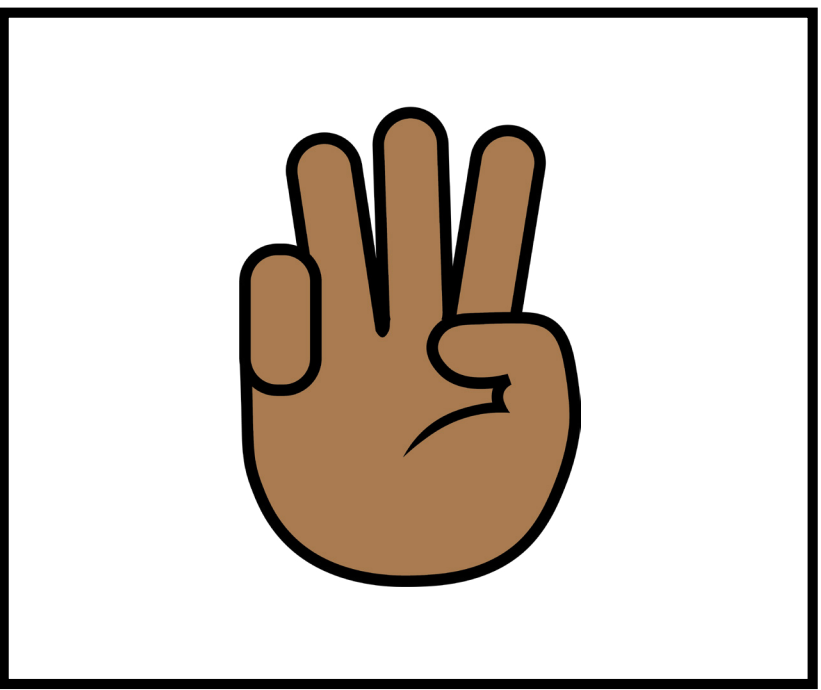
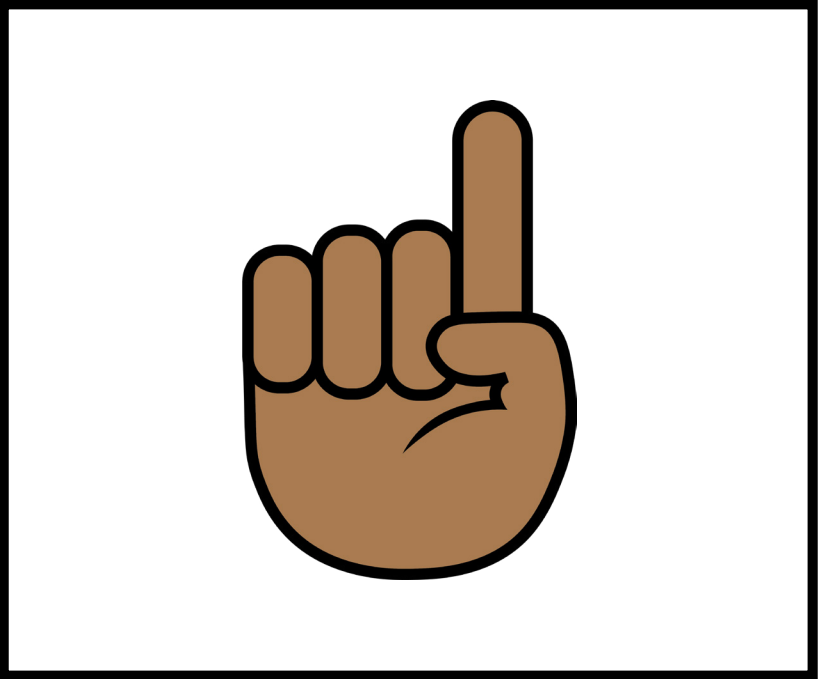
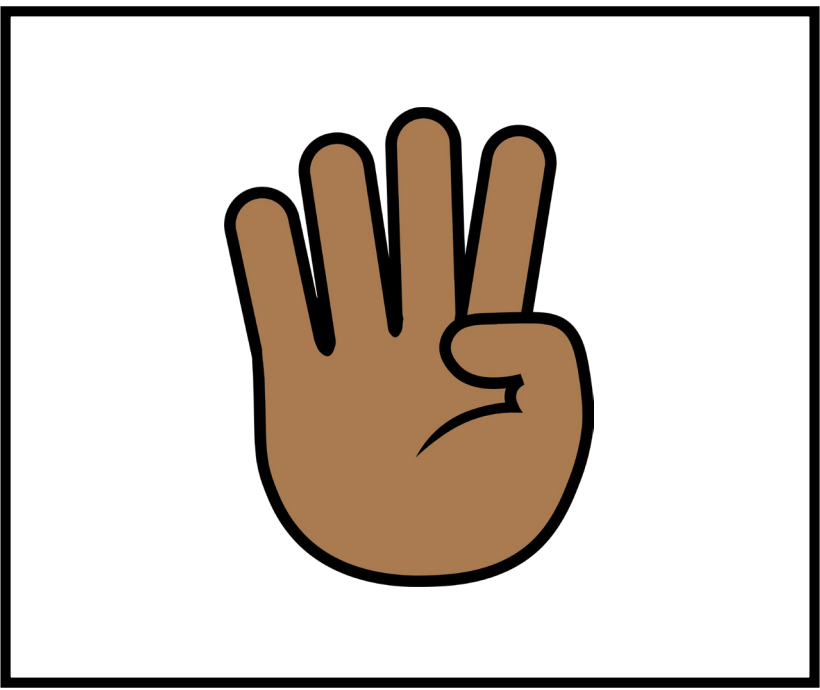
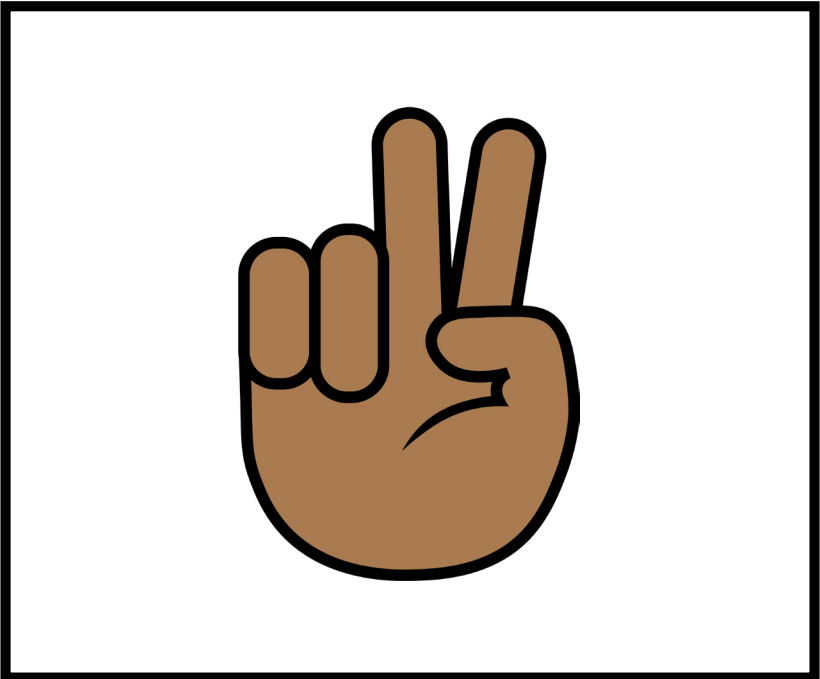

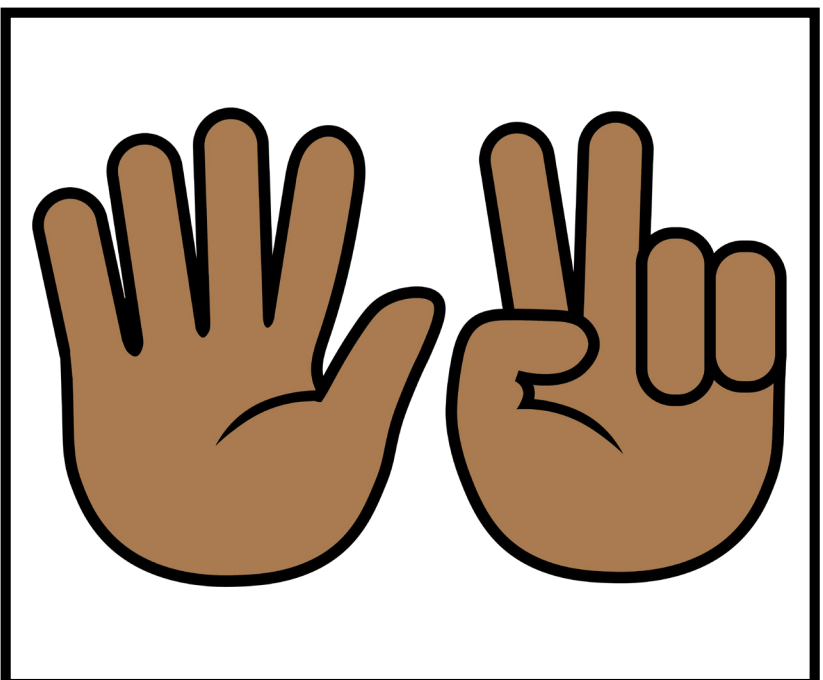
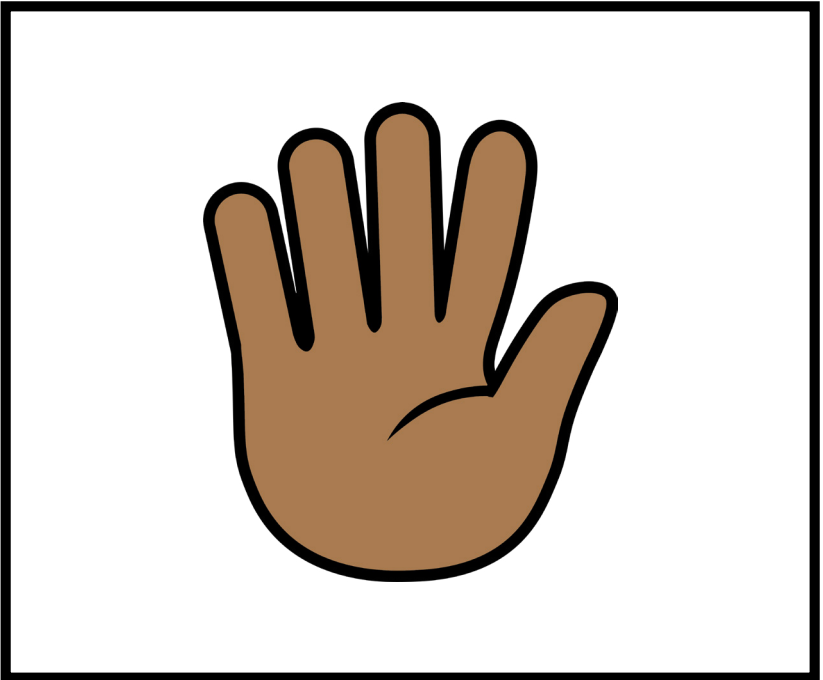
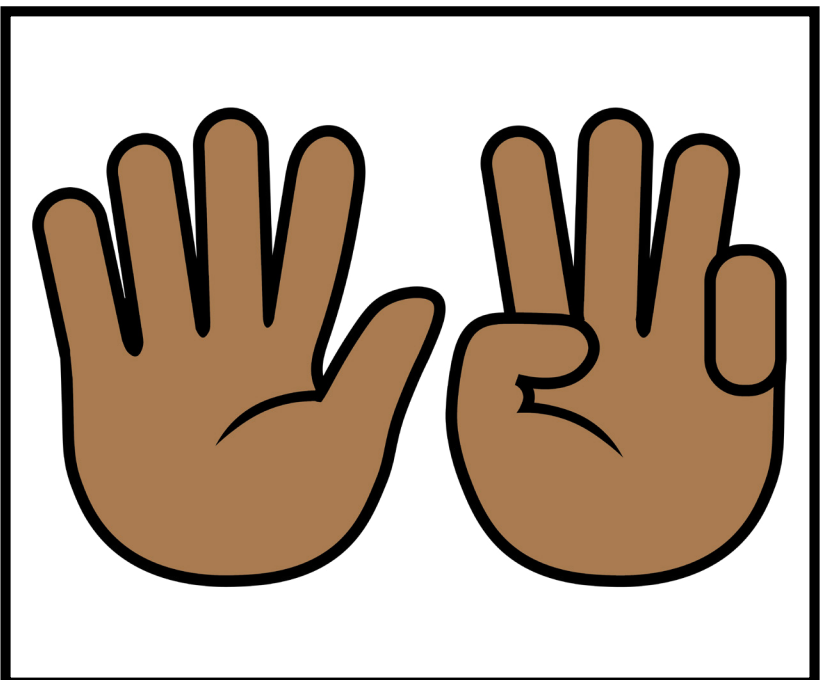
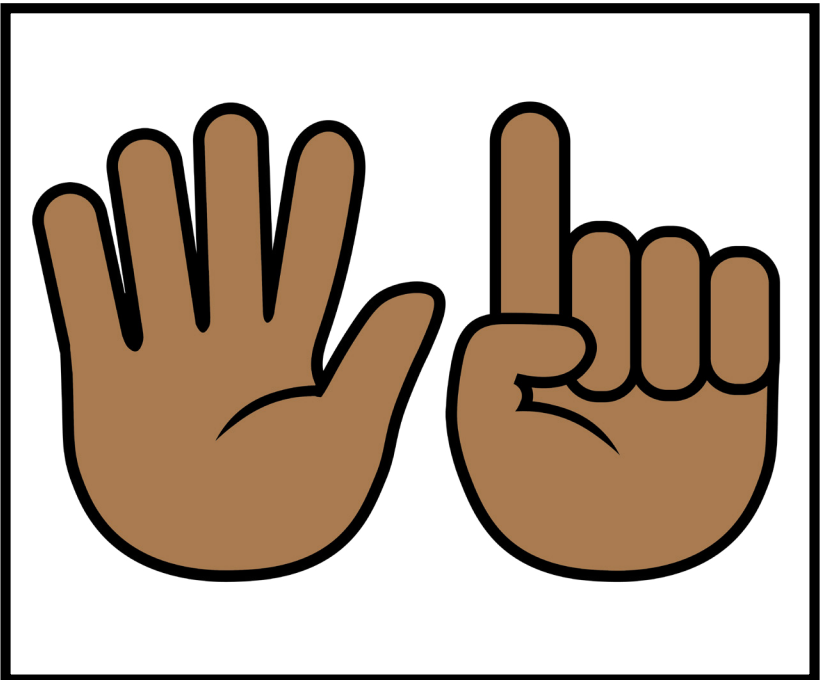

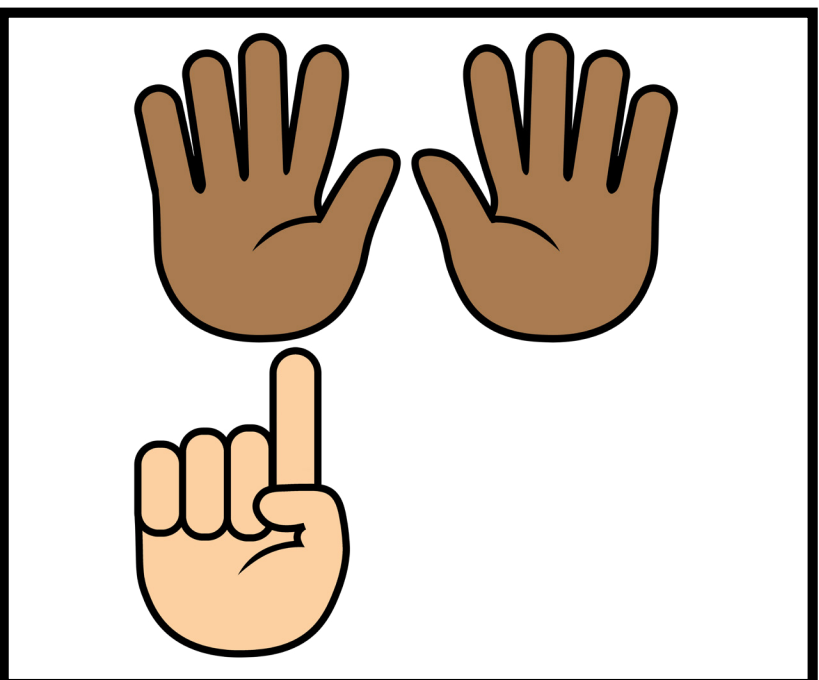
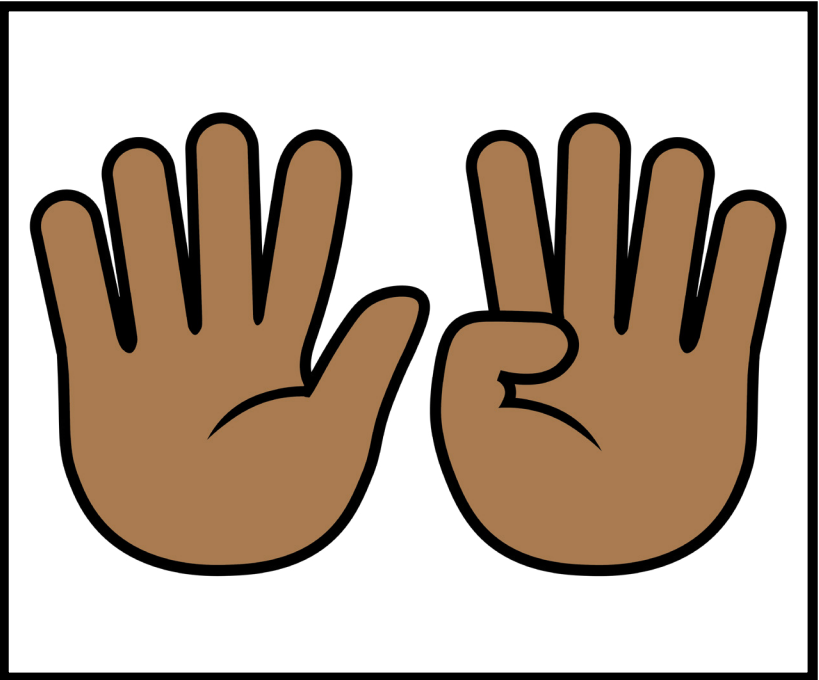
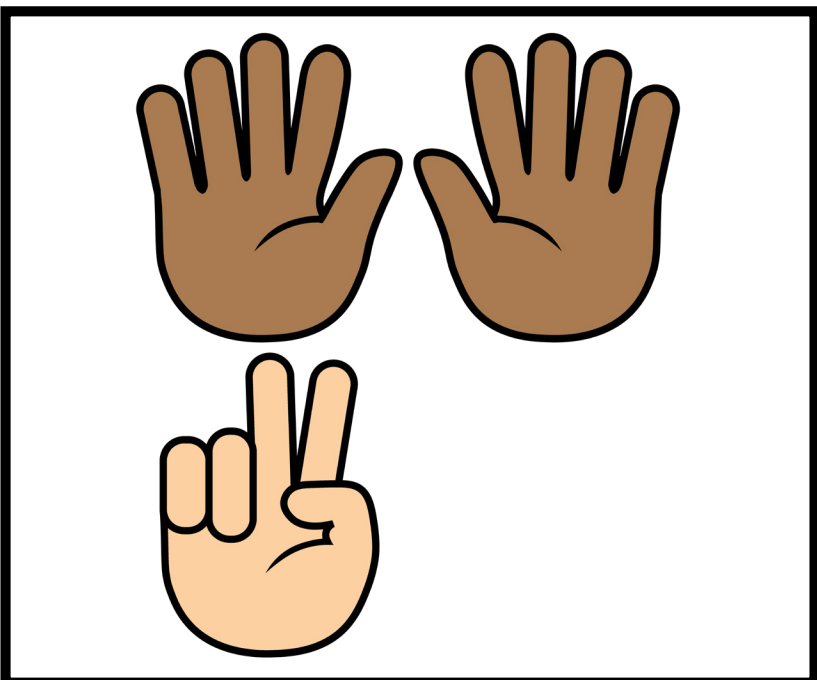
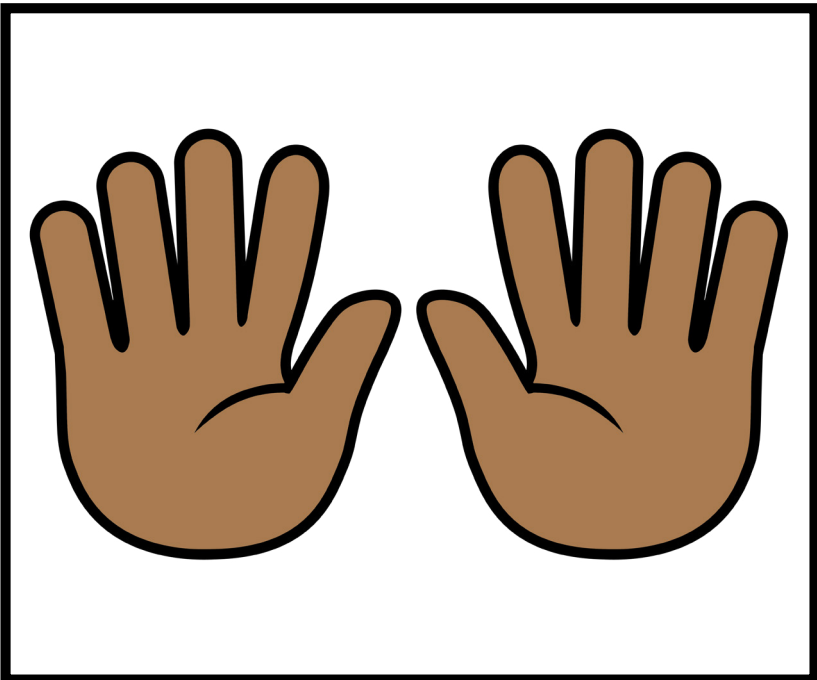

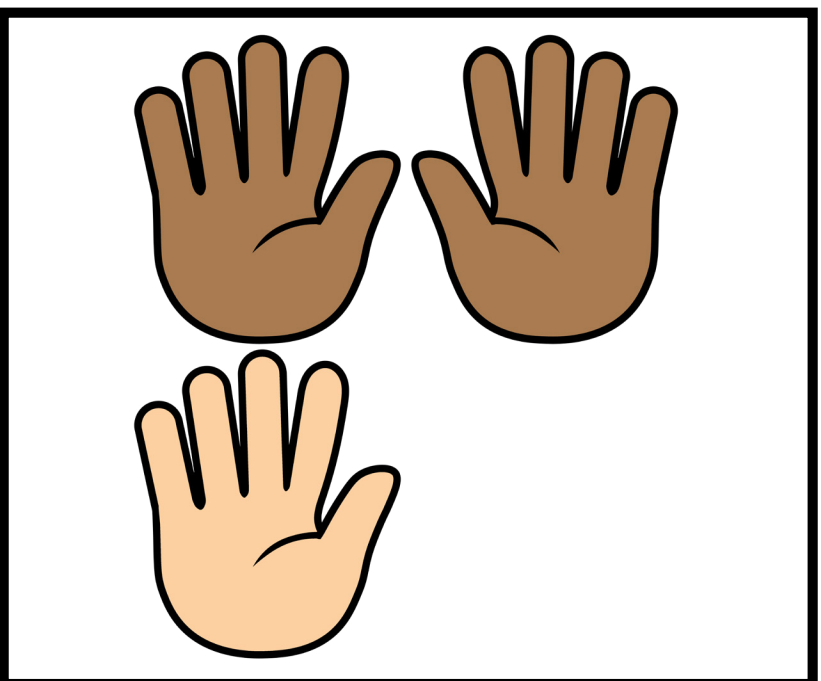
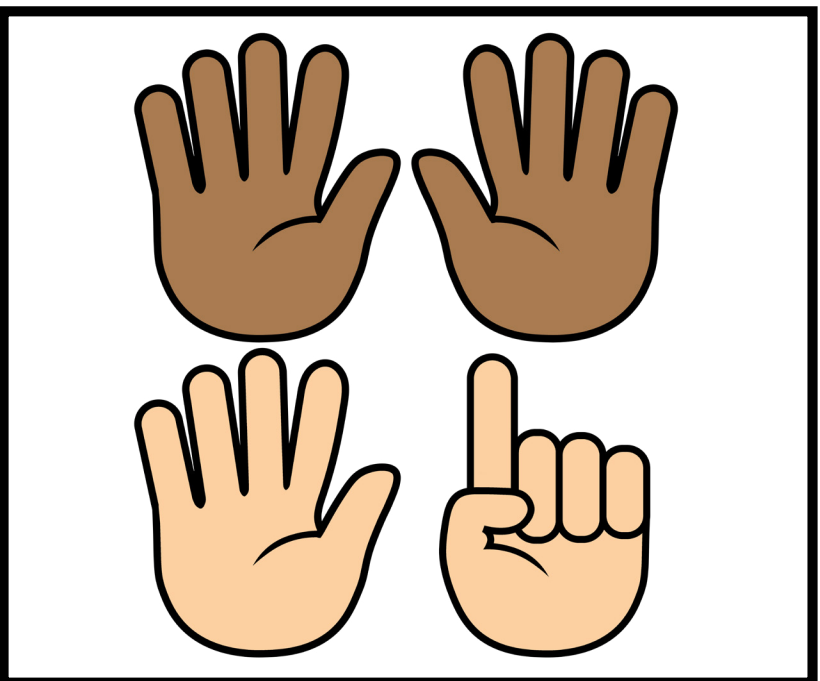
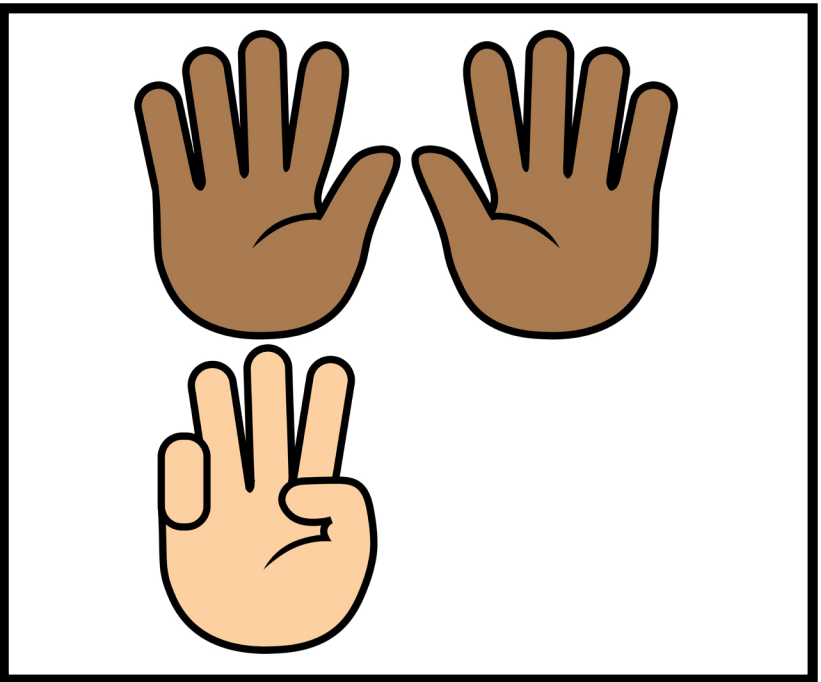
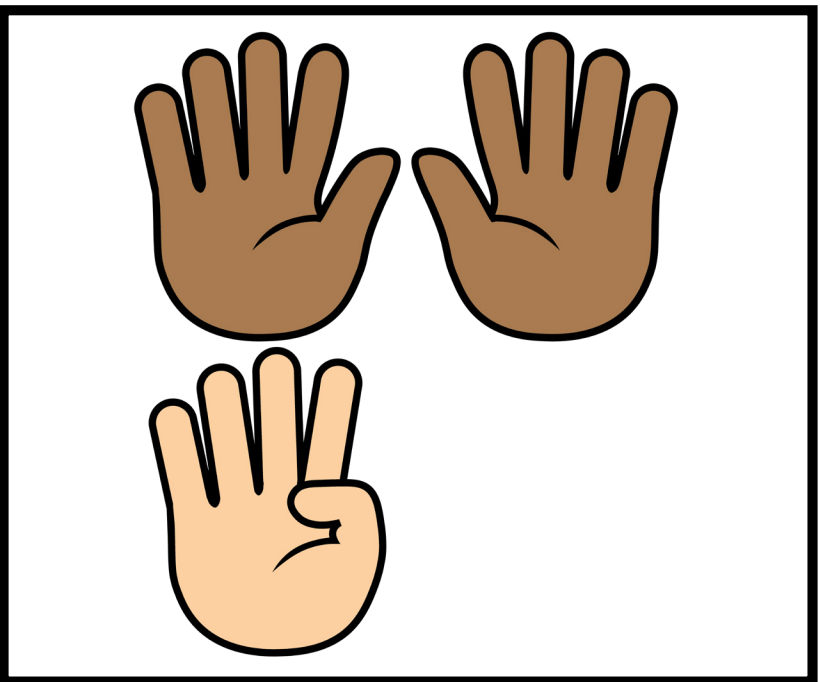

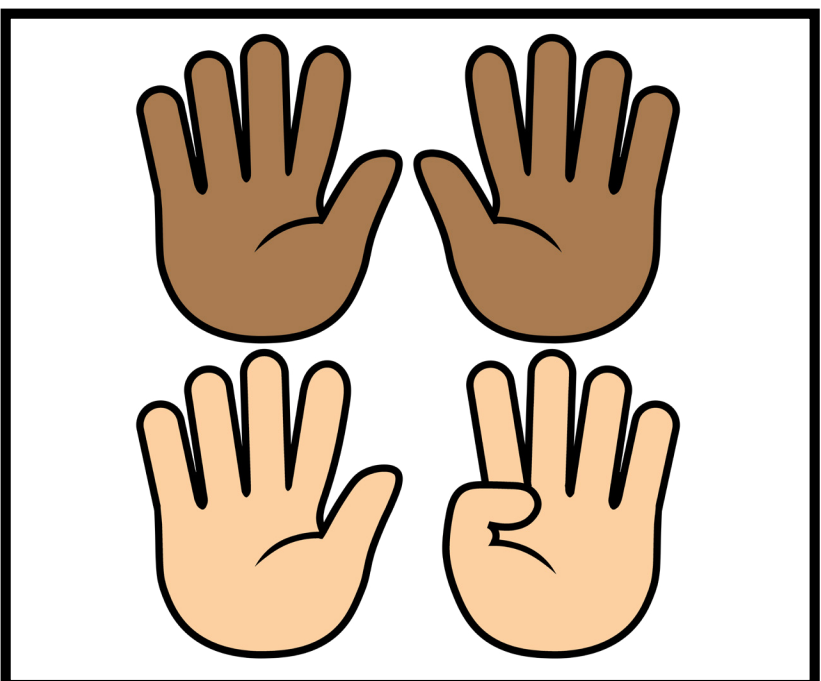
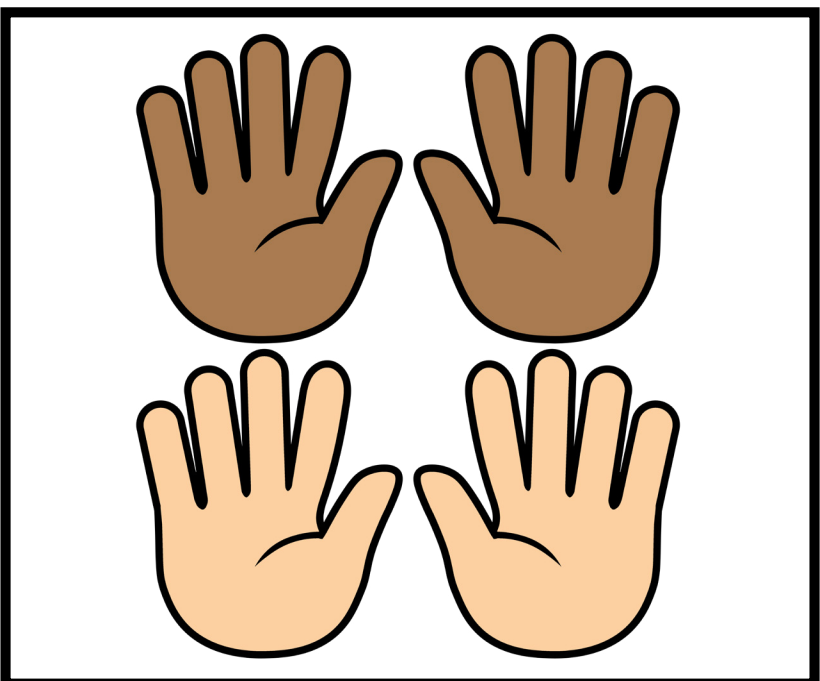
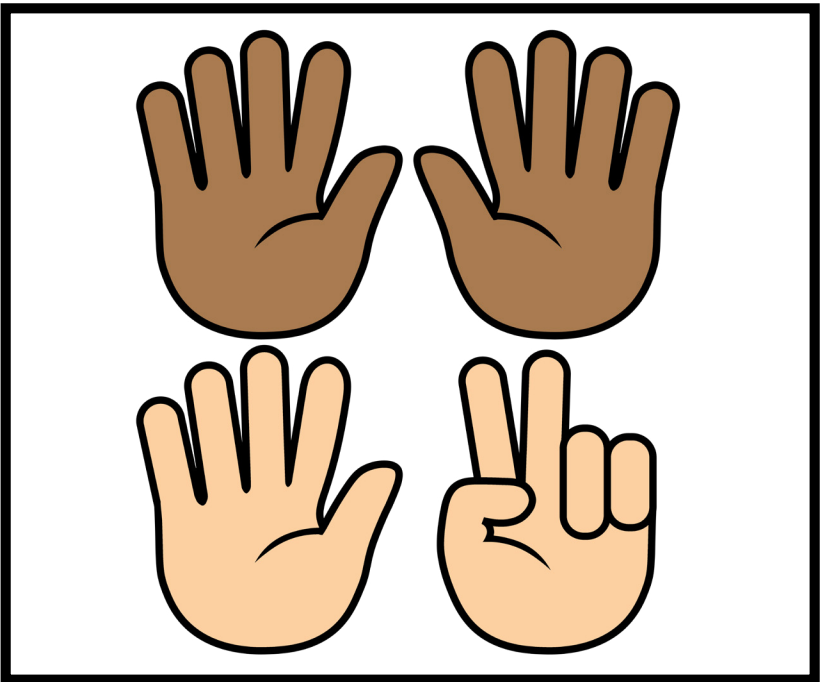
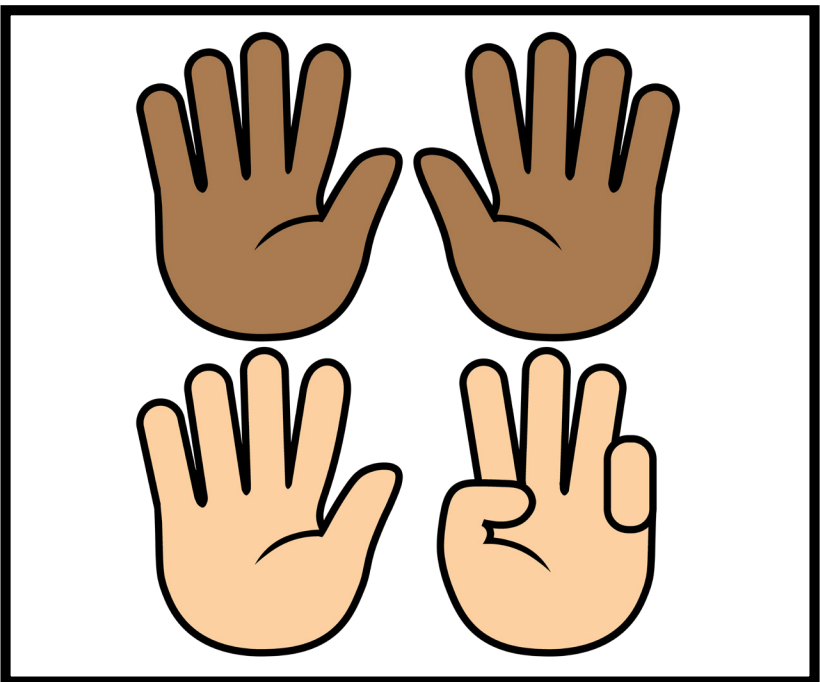















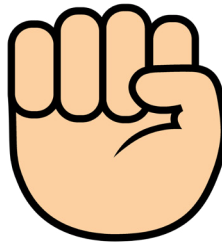





1	 
 	



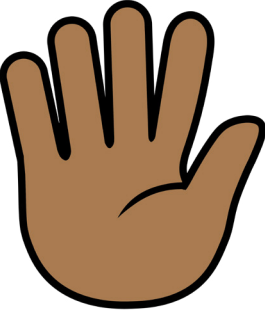

0	 
 	

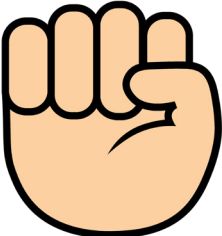

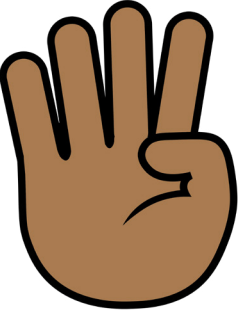

3	 
 	



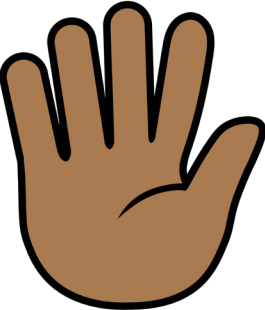

2	 
 	

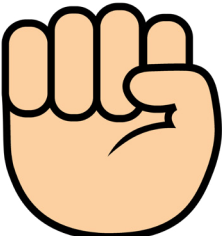

5		
		

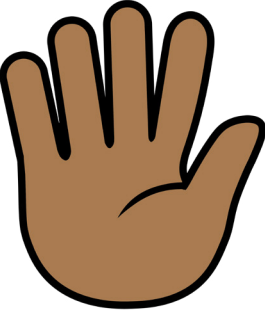
4		
		

7		
		

6		
		



9

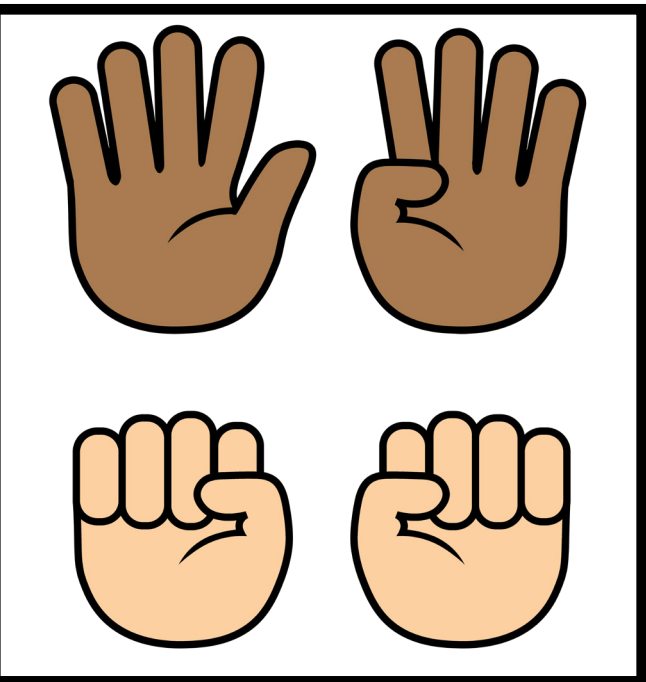

11

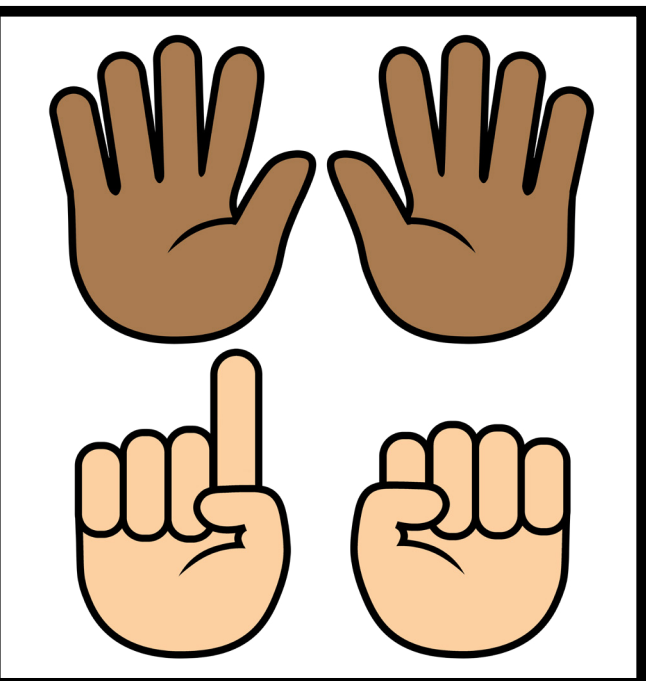

8

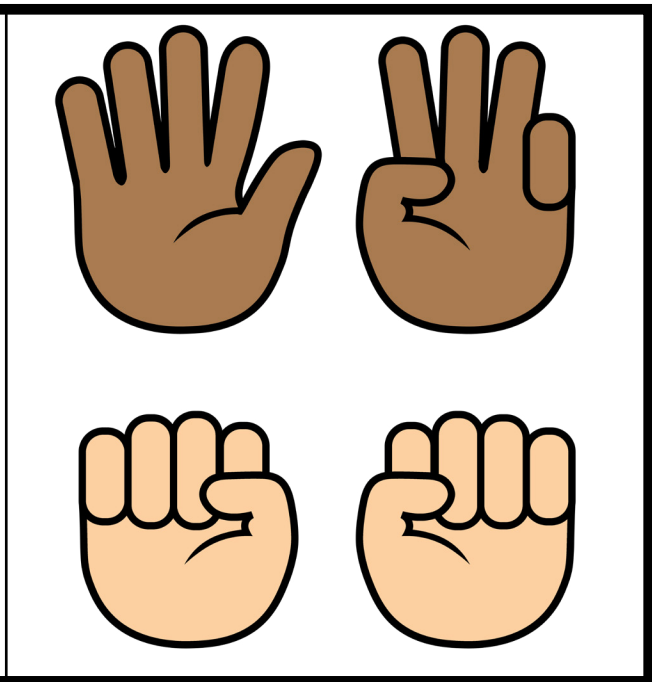

10

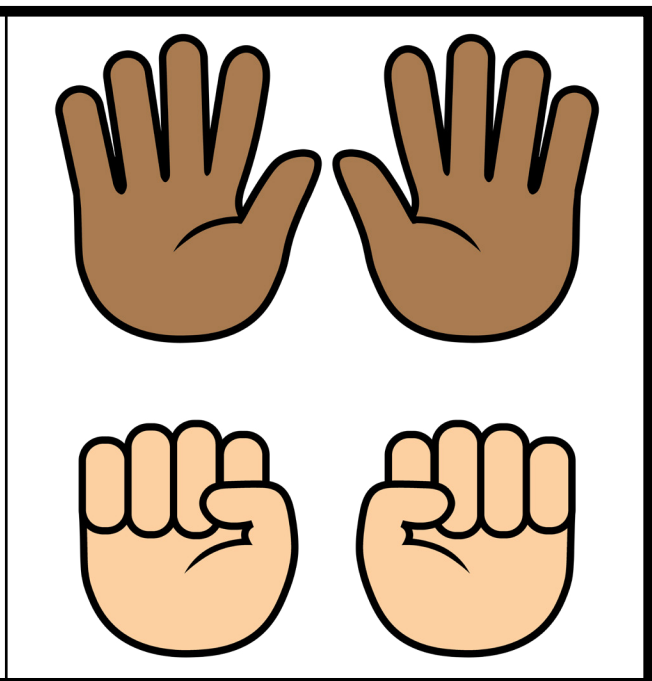

13

12

15

14



17

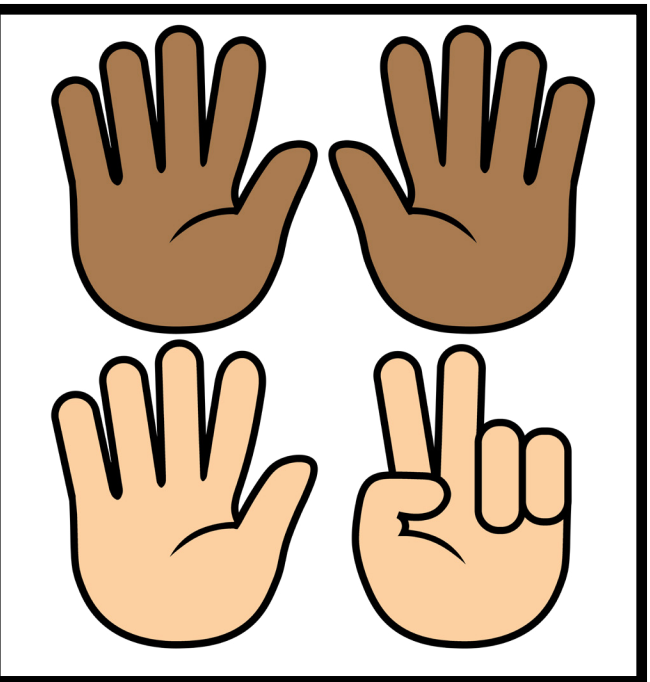

16

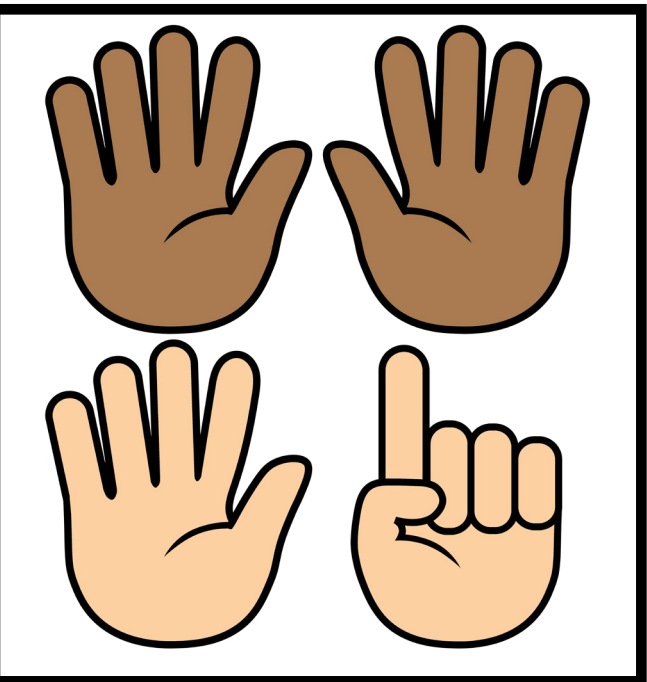

19

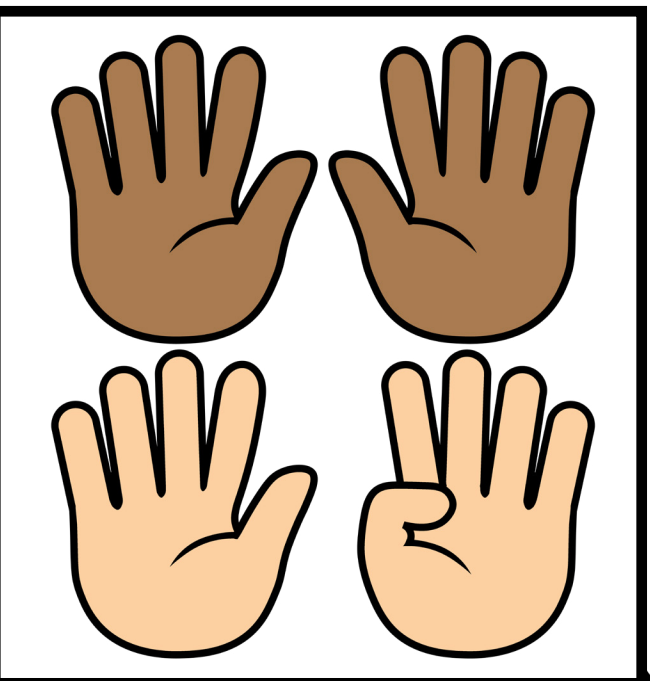

18

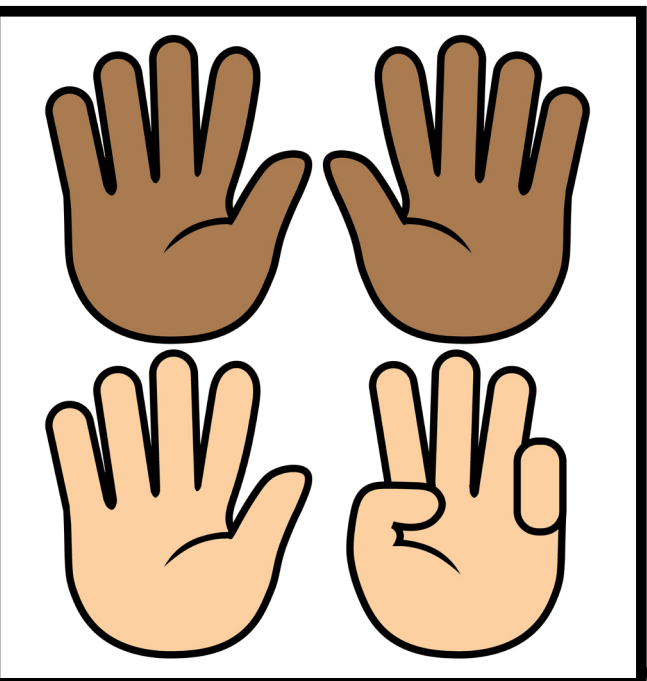

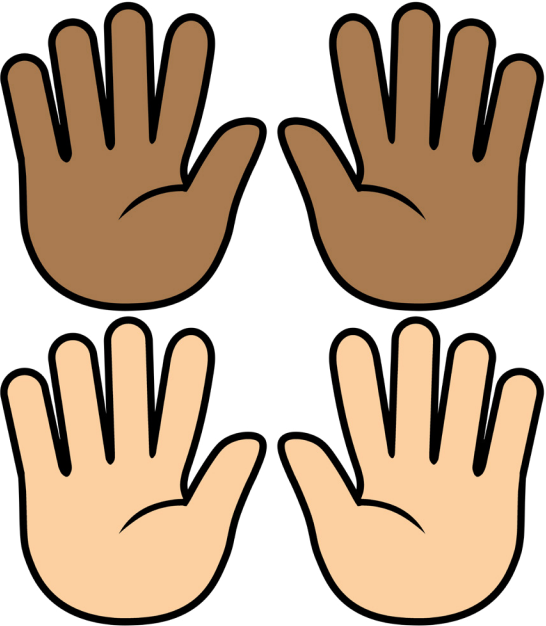

	<p data-bbox="157 342 361 488">20</p>
----------------------------------------------------------------------------------	---------------------------------------



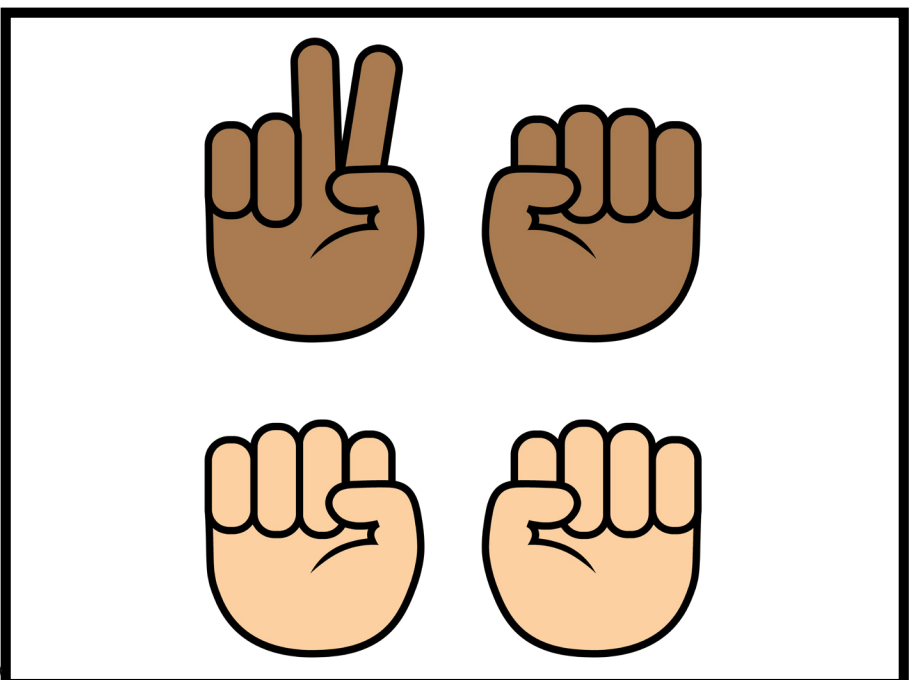
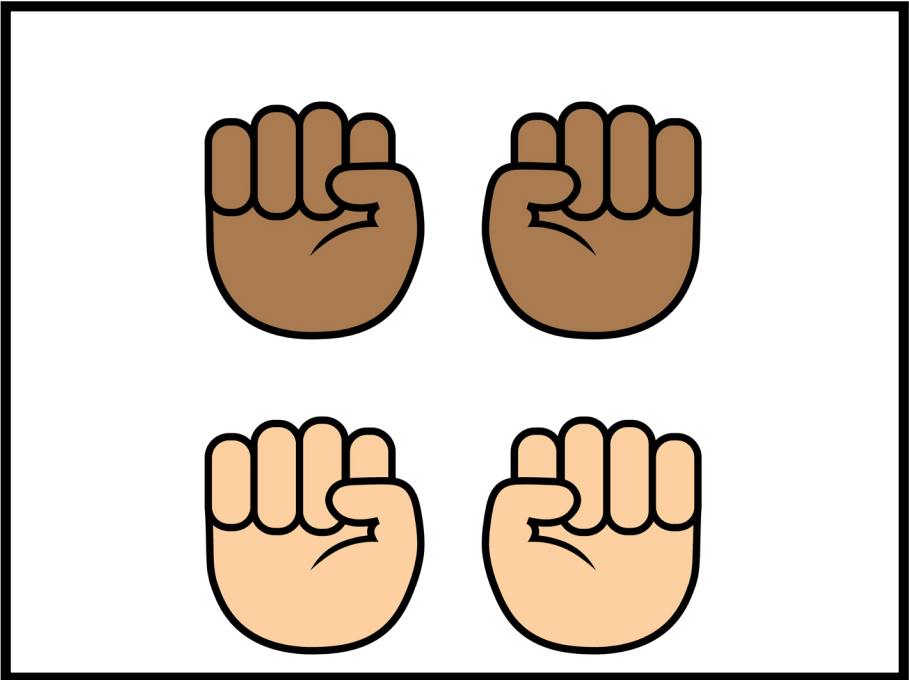
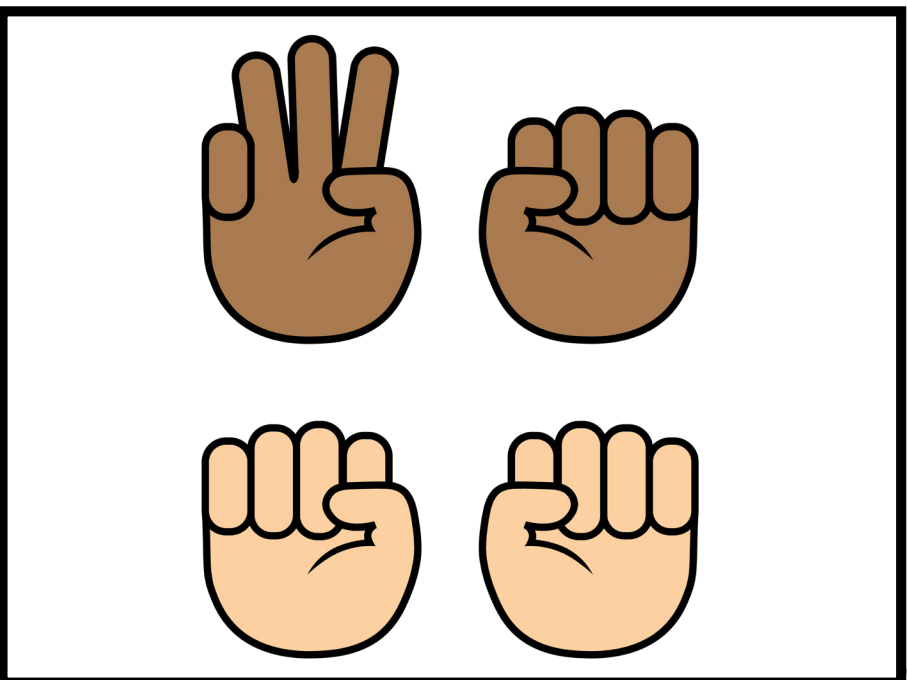
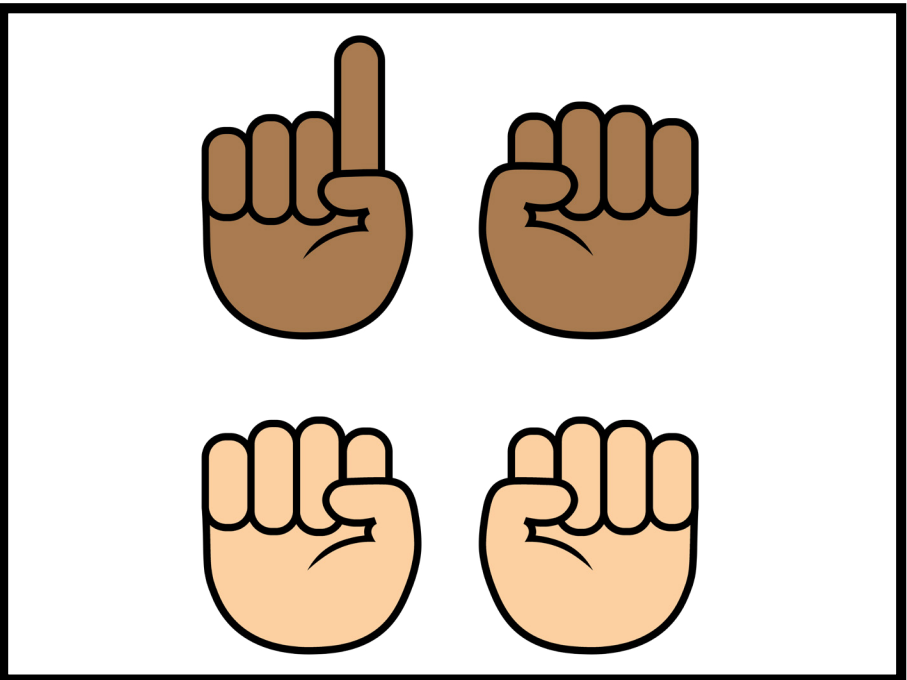

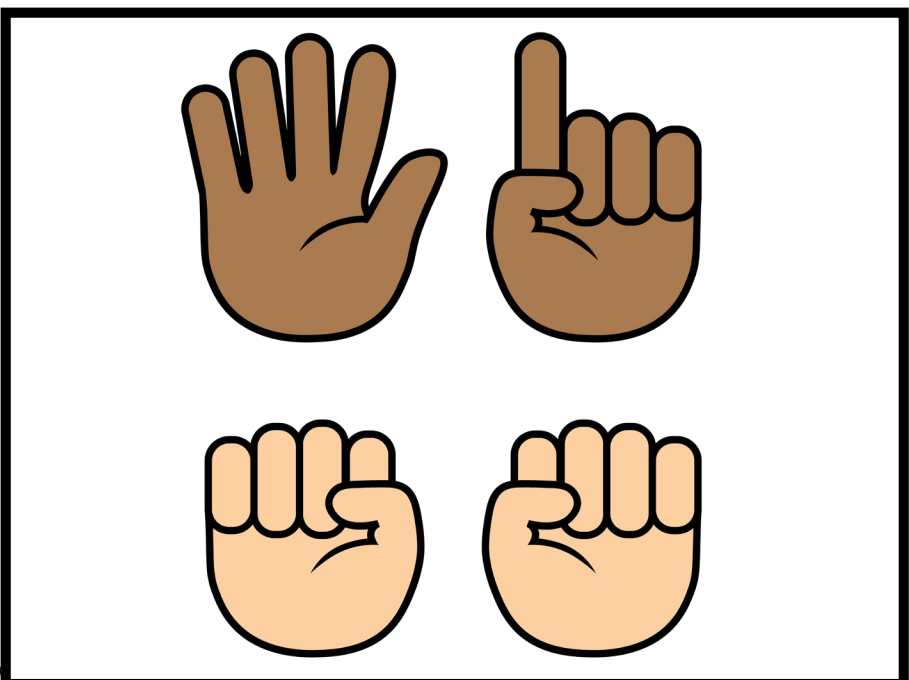
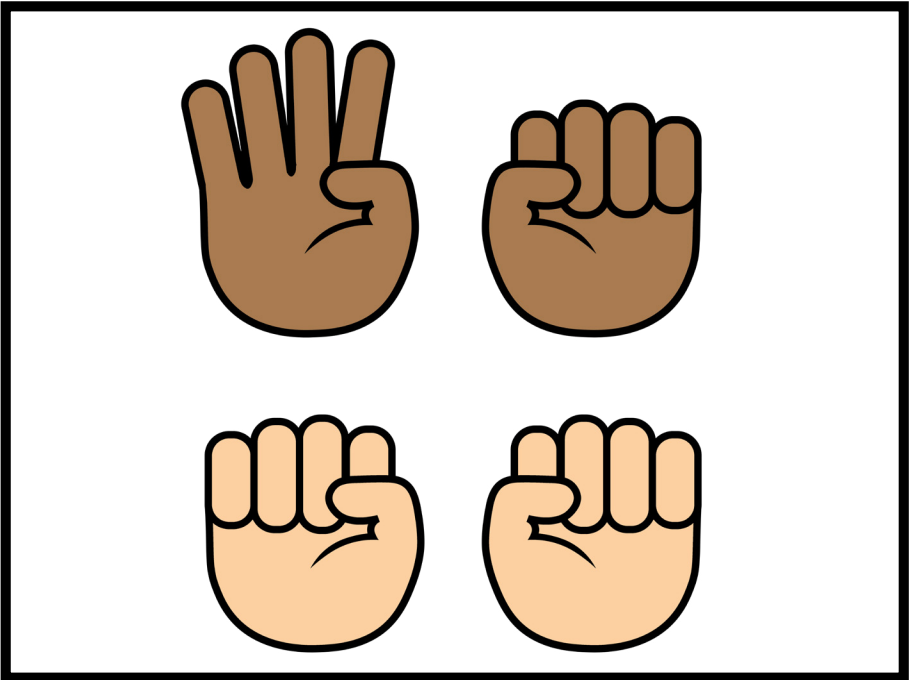
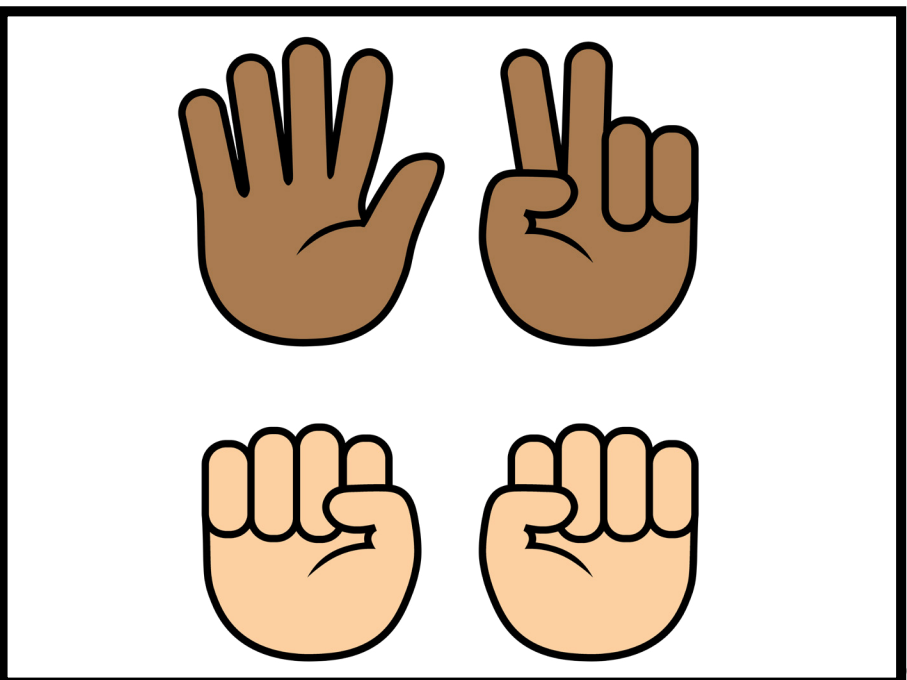
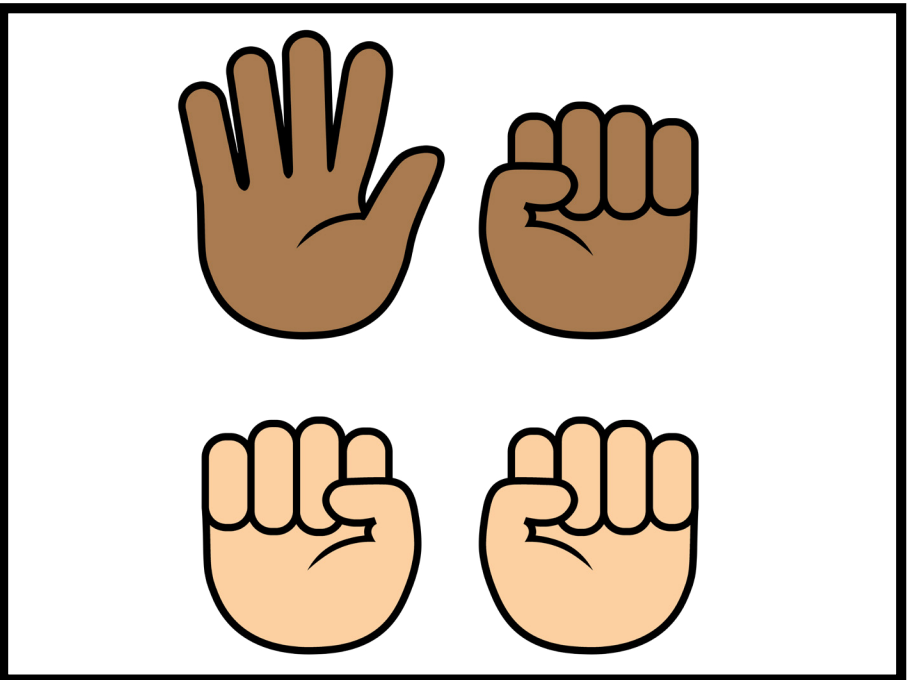

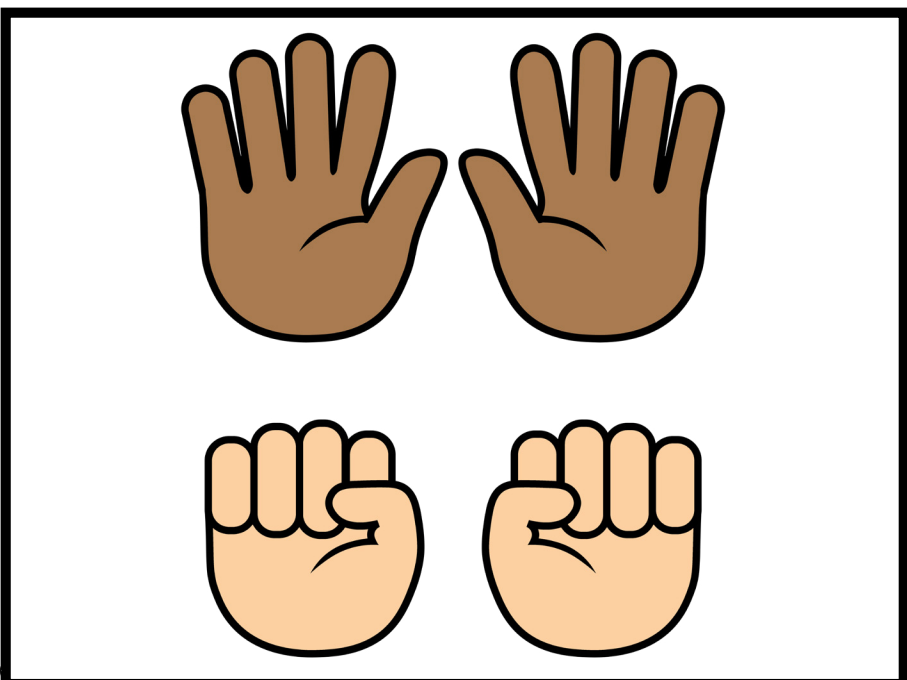
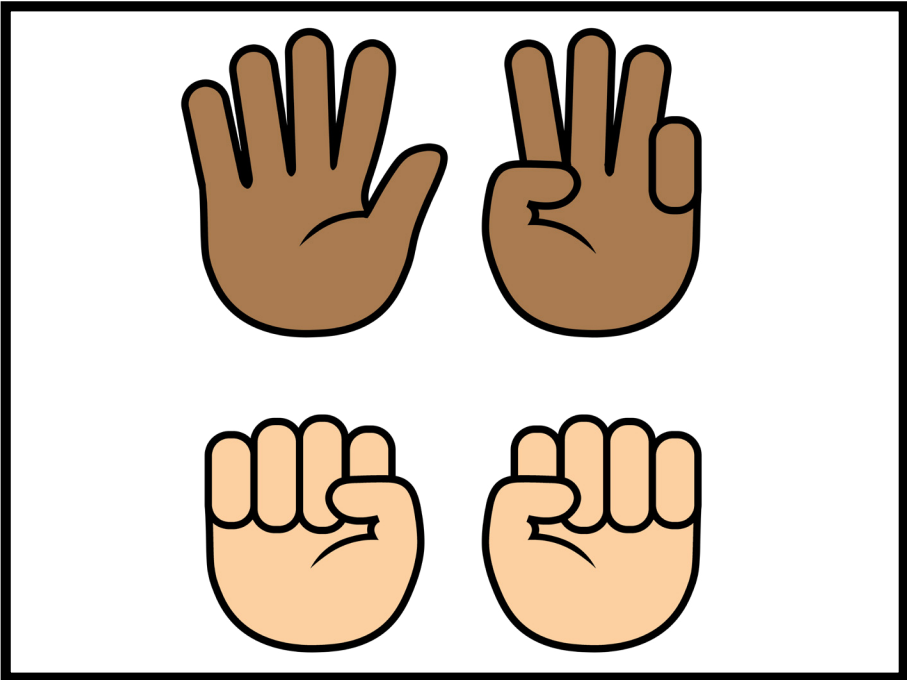
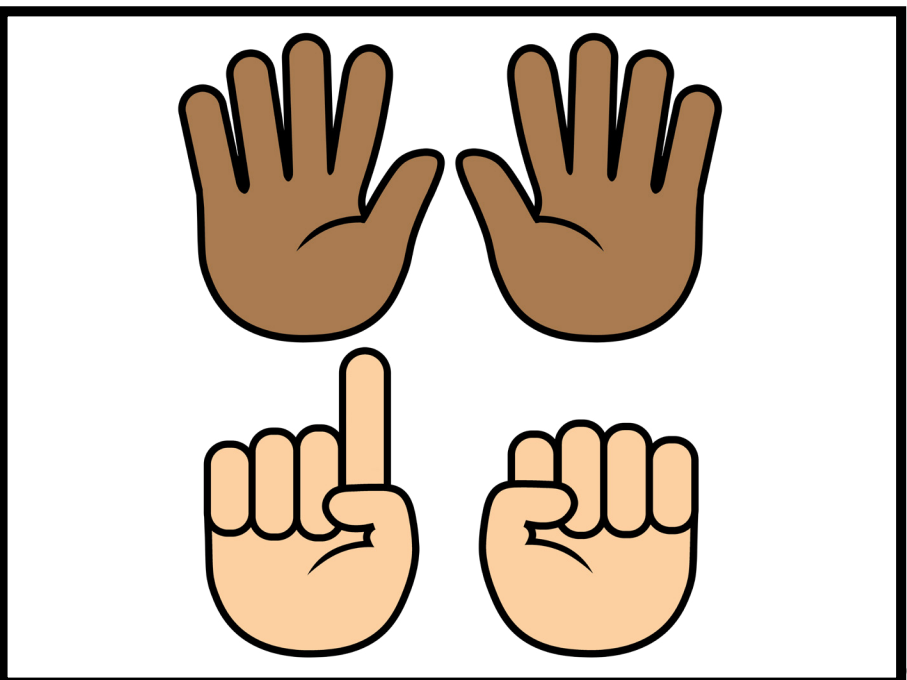
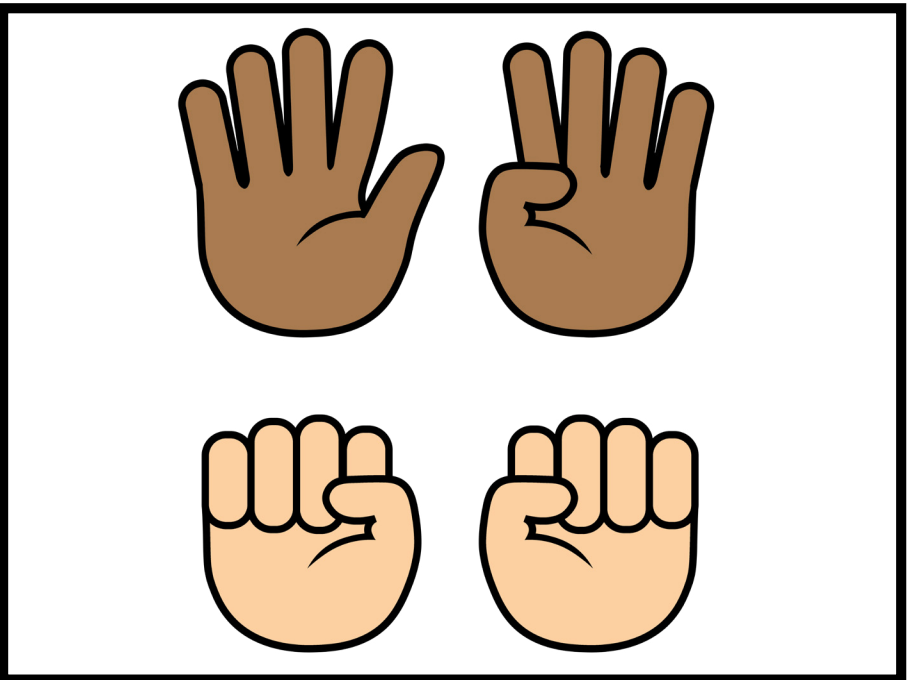



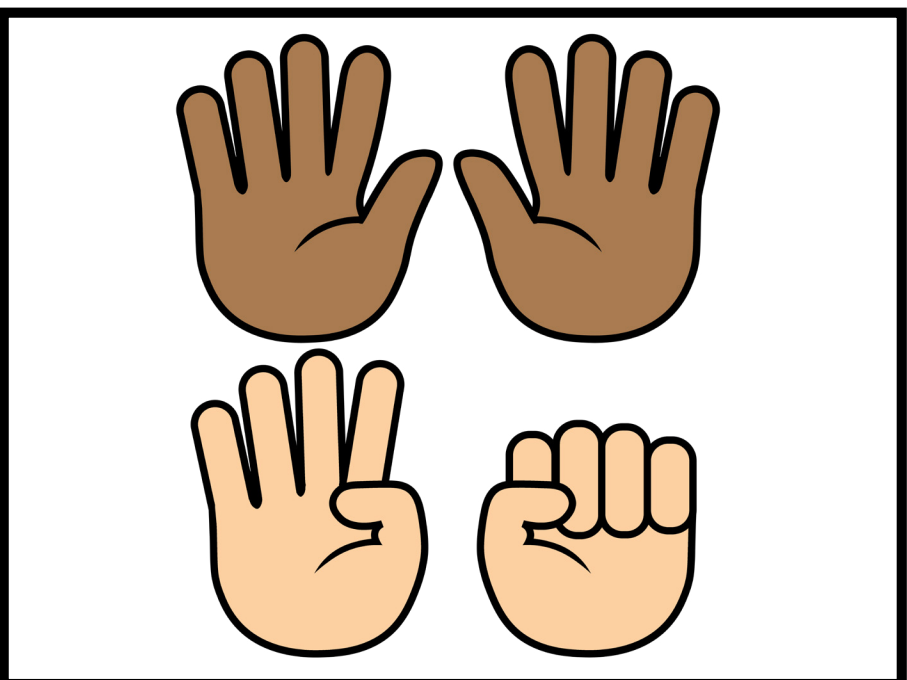
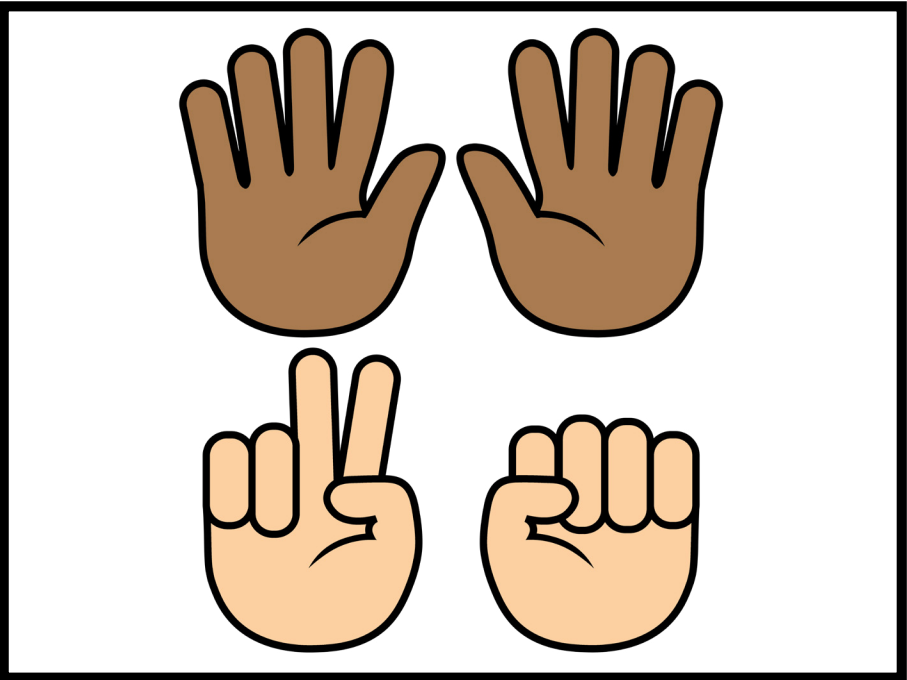
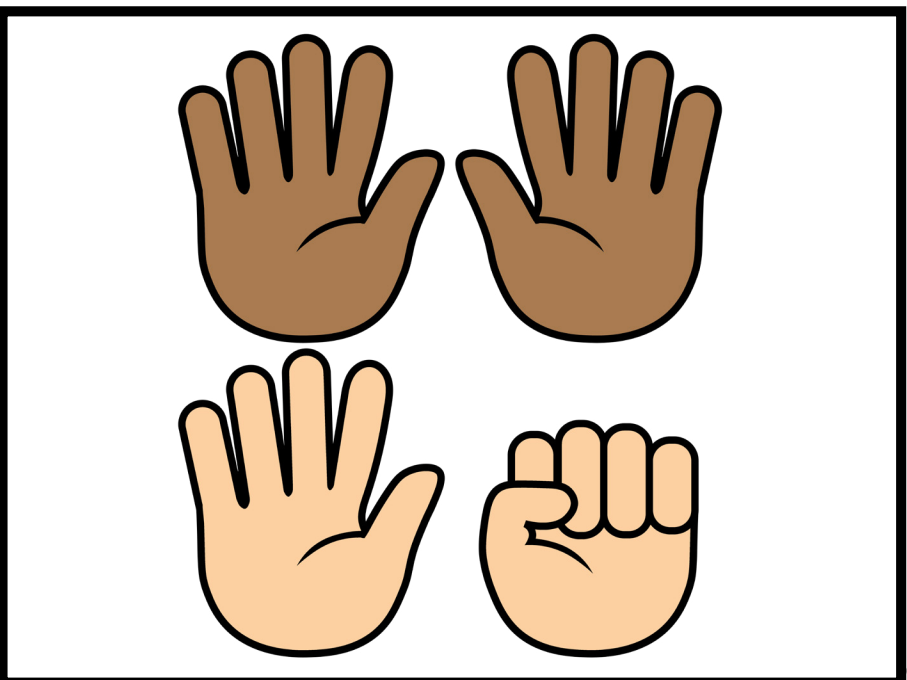
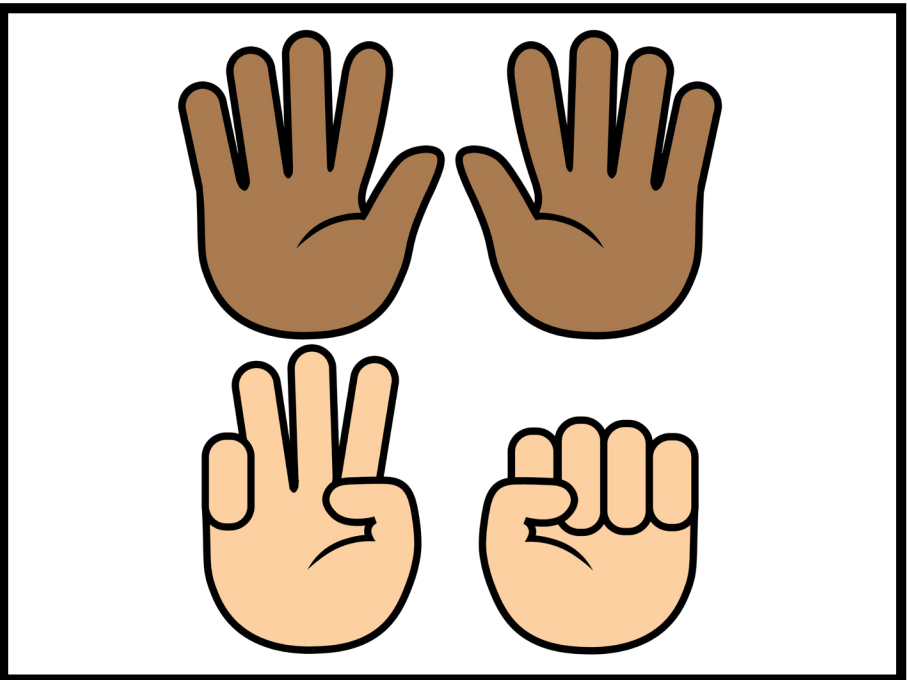



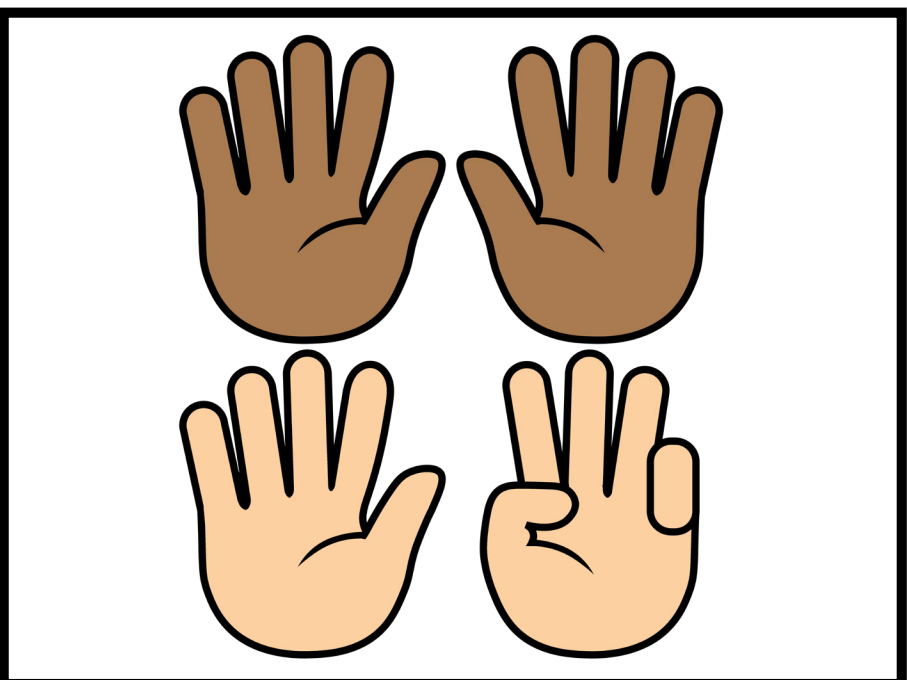
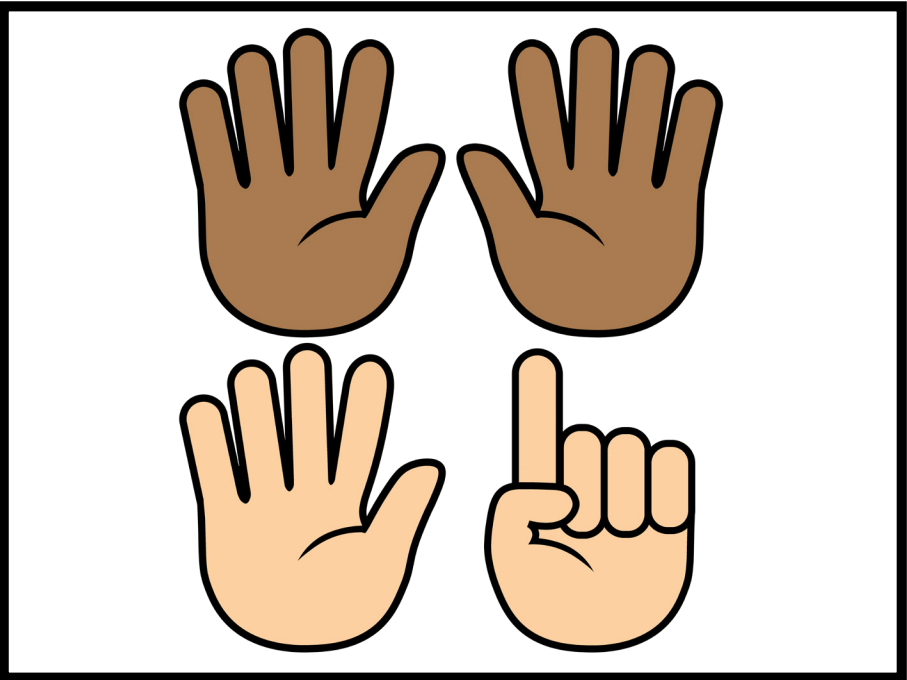
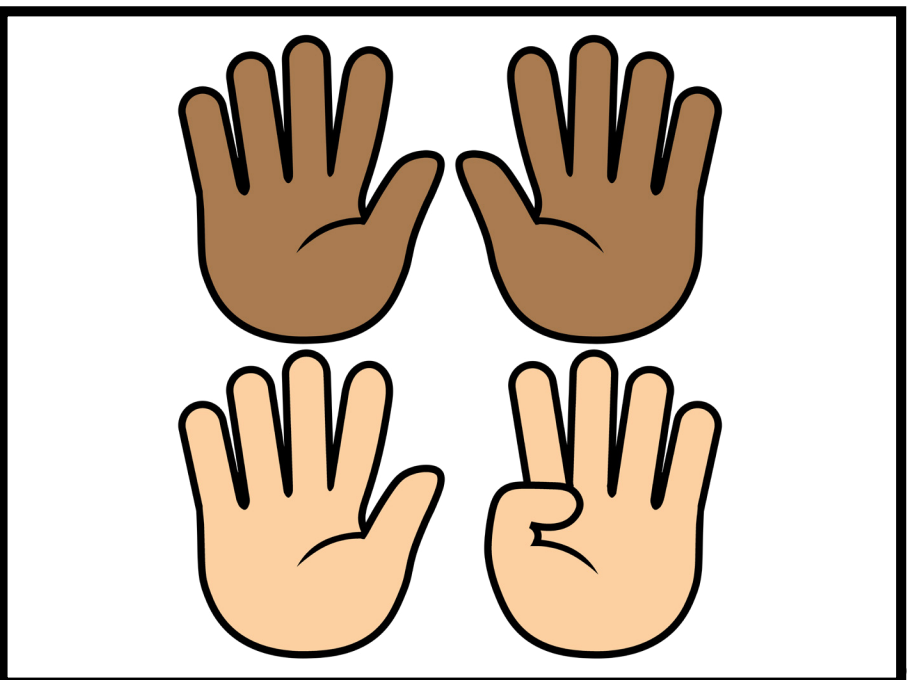
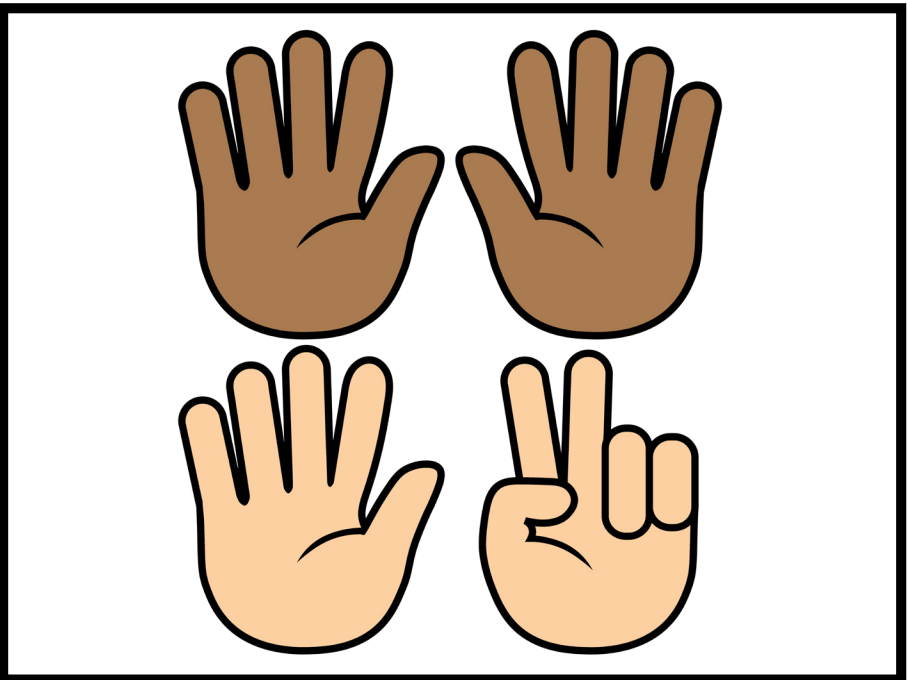

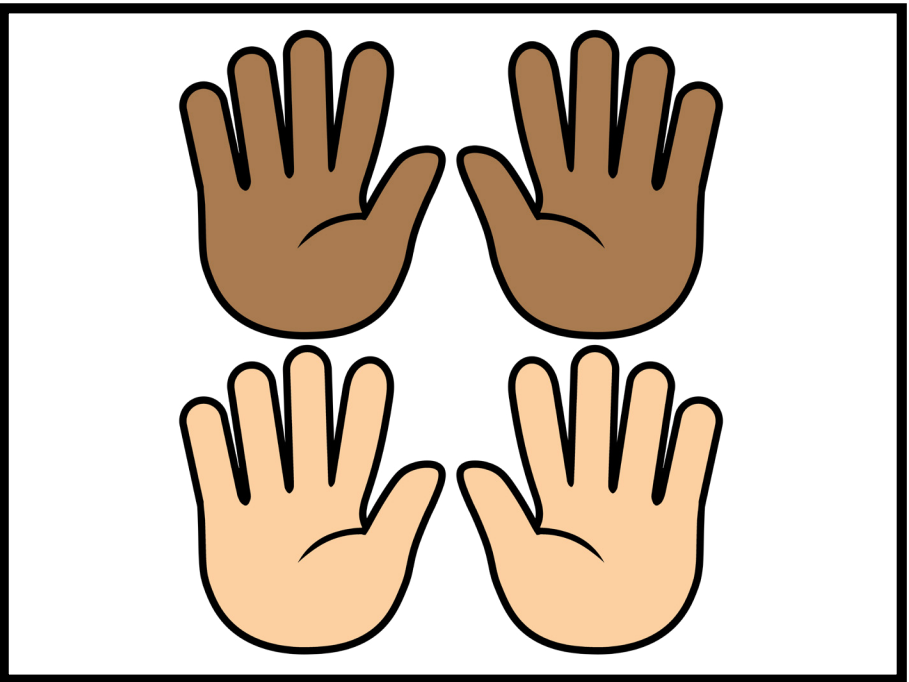



# Dé

1. Coupez le long de lignes pleines.
2. Pliez sur les lignes pointillées.
3. Mettez de la colle sur les languettes et collées.

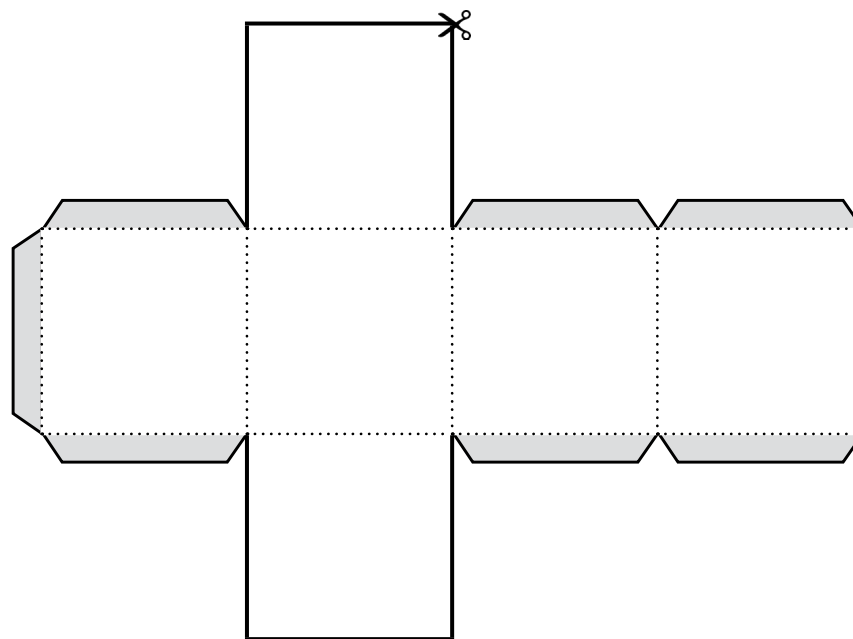
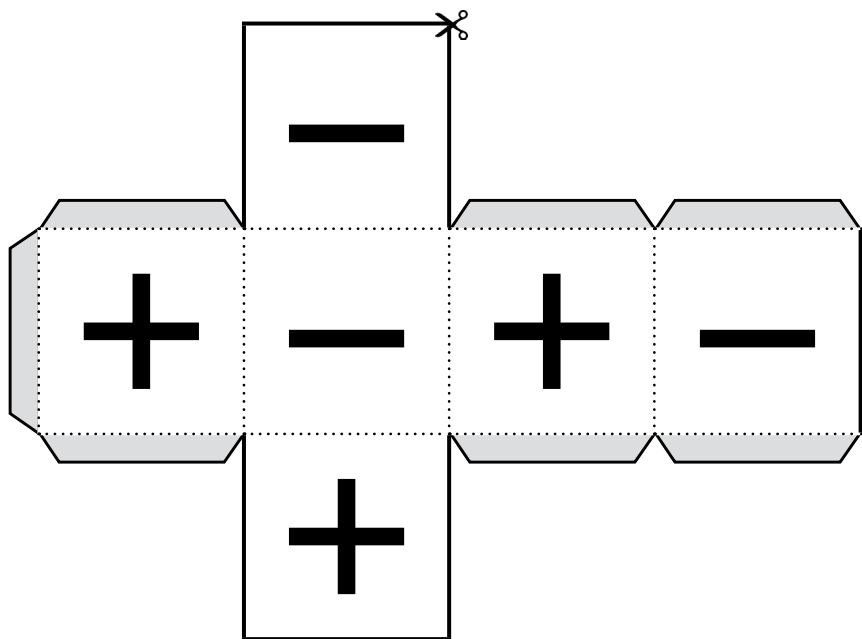
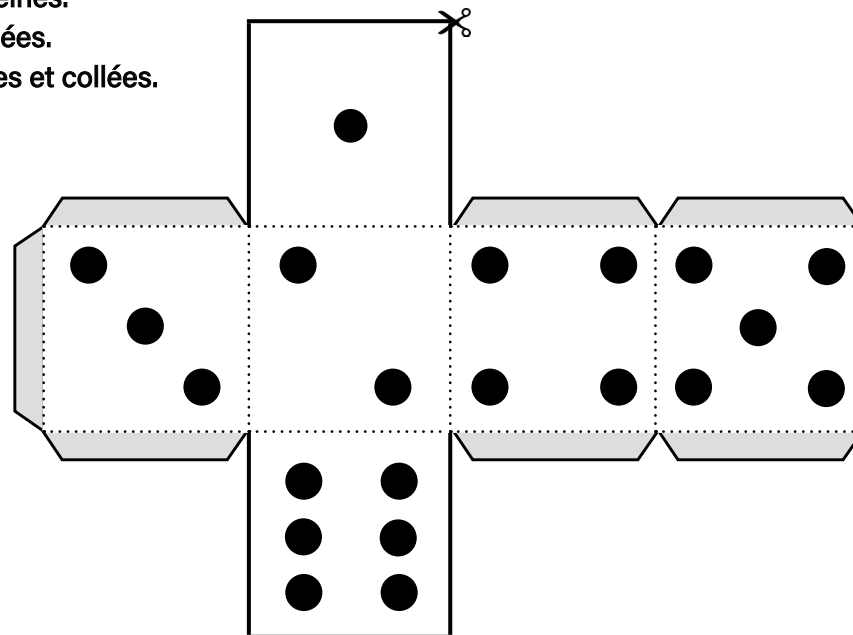
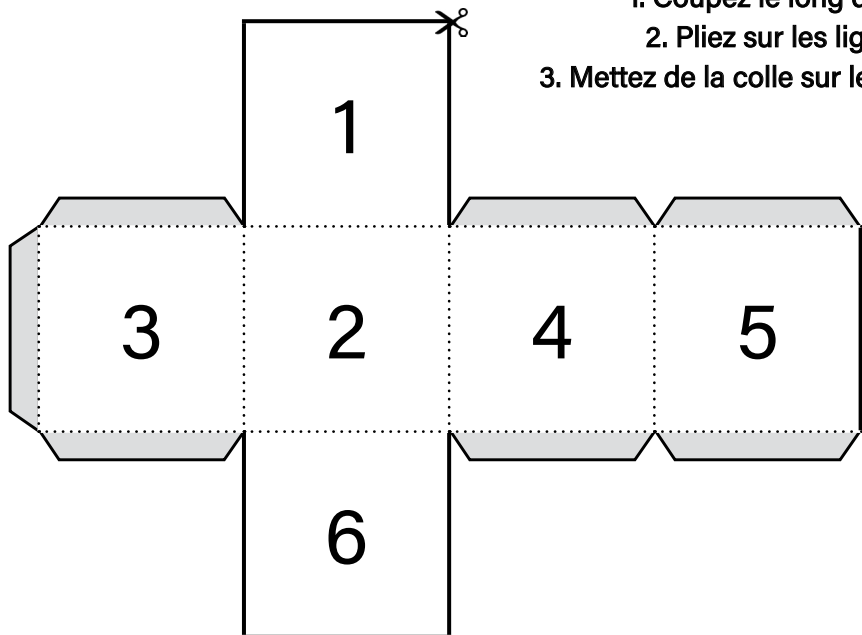

# Cube

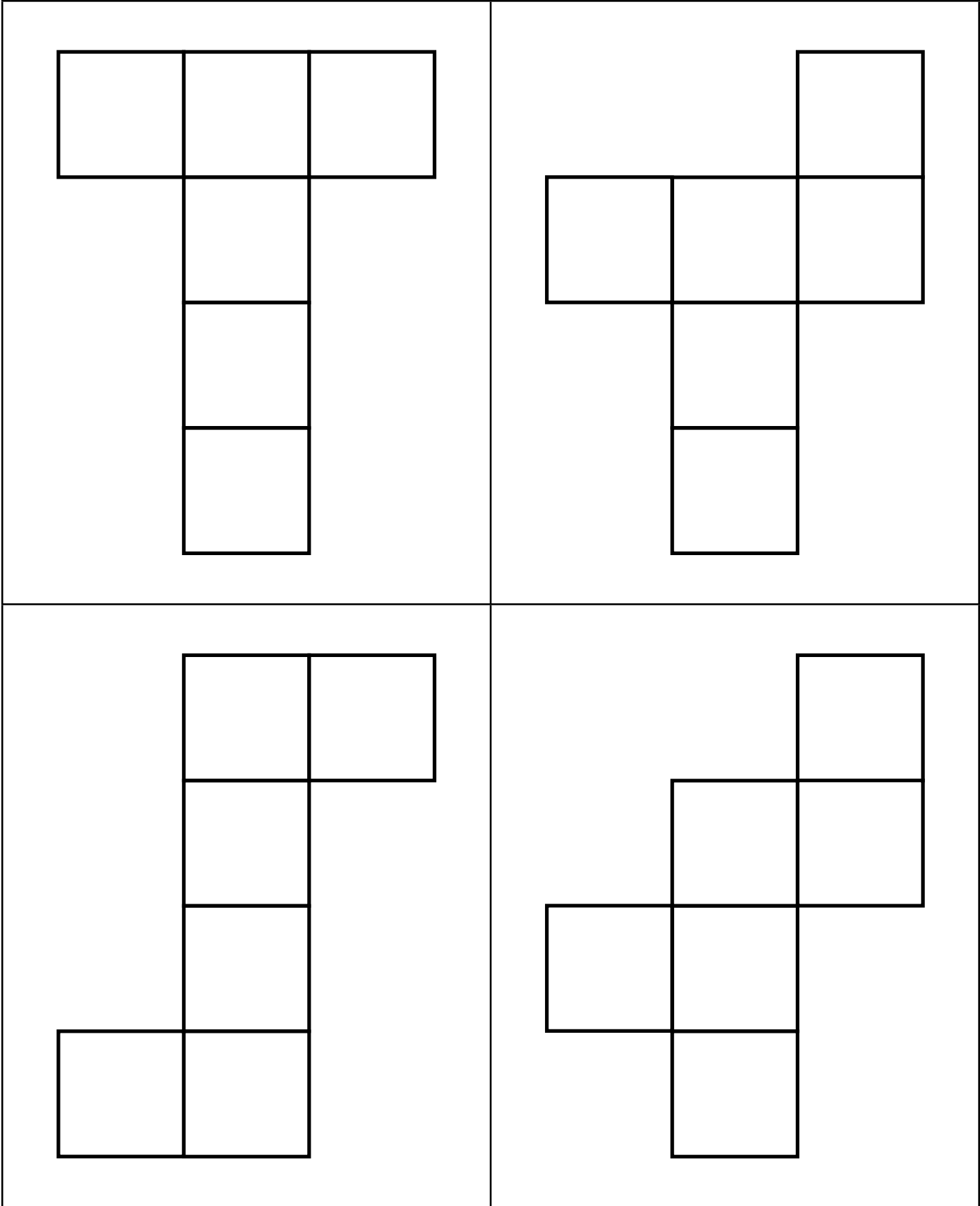

# Cube

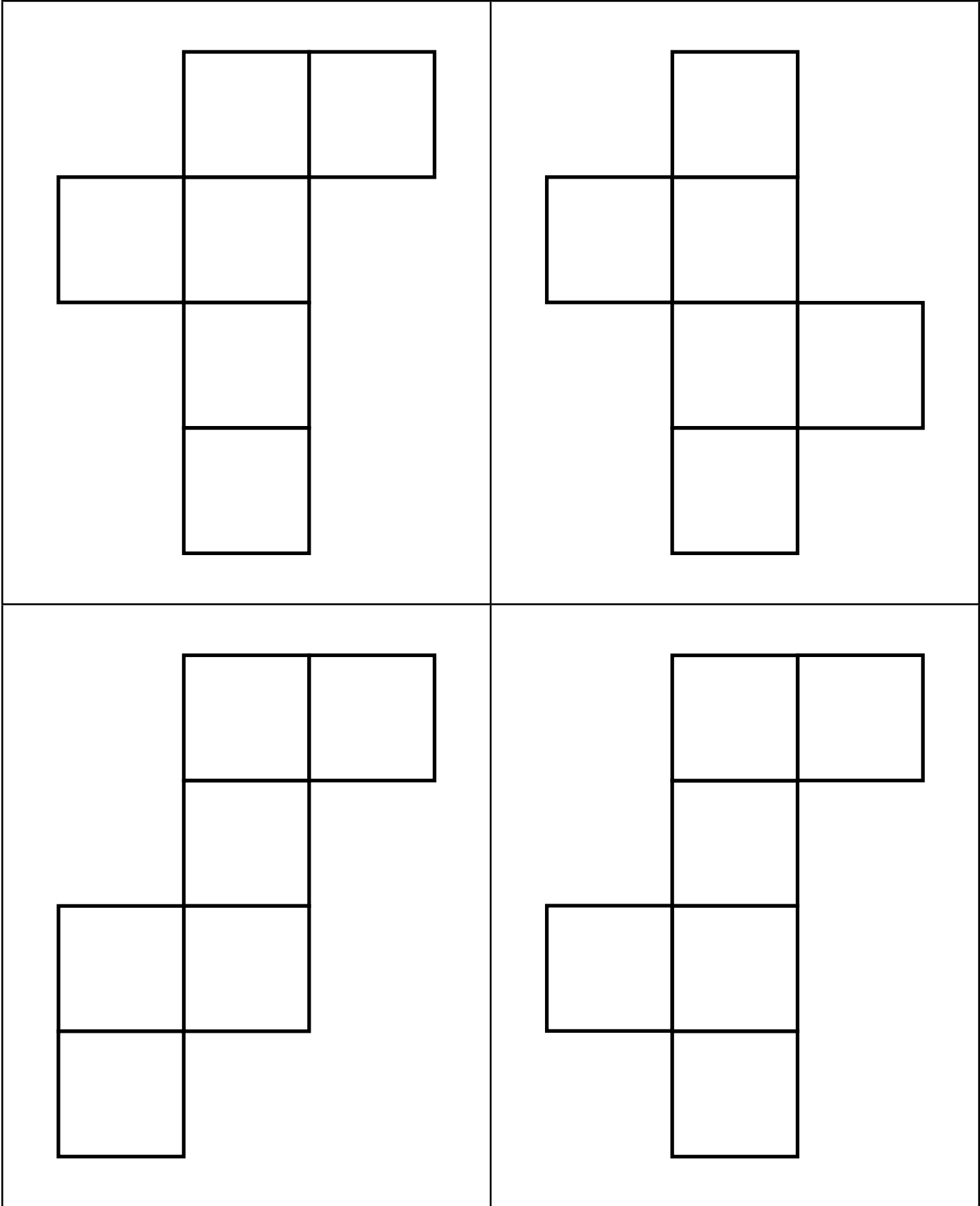

# Cube

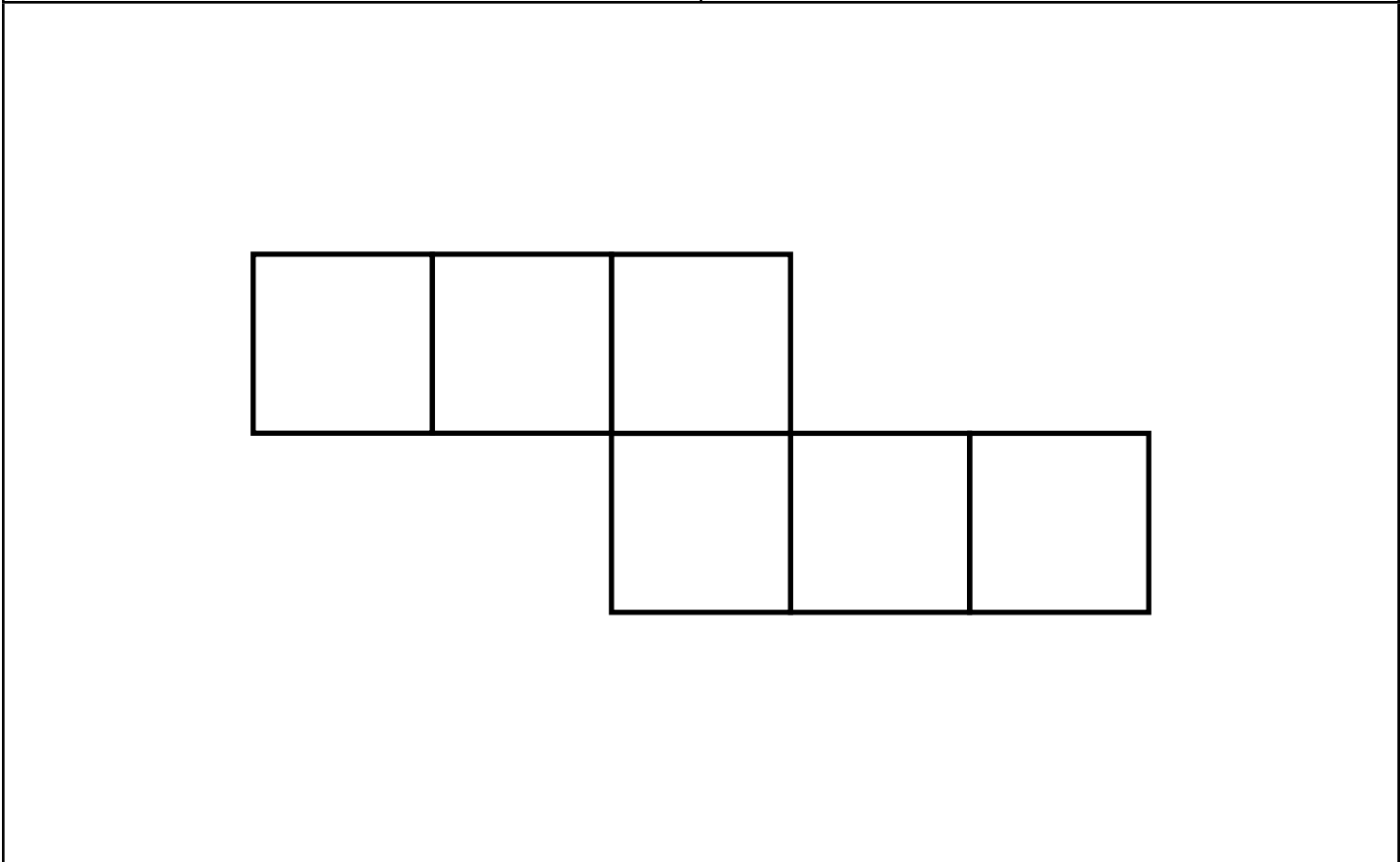
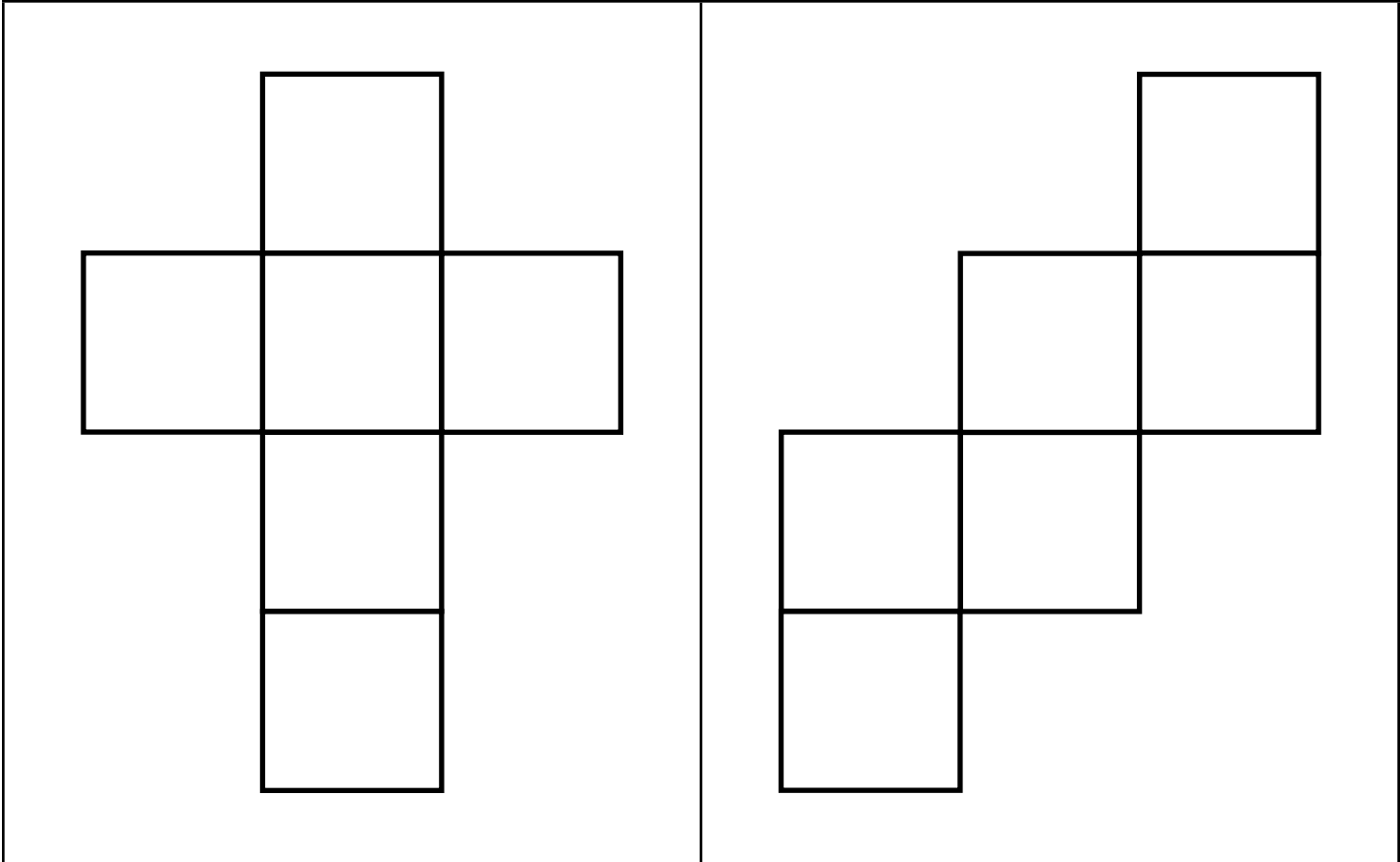

# Cube

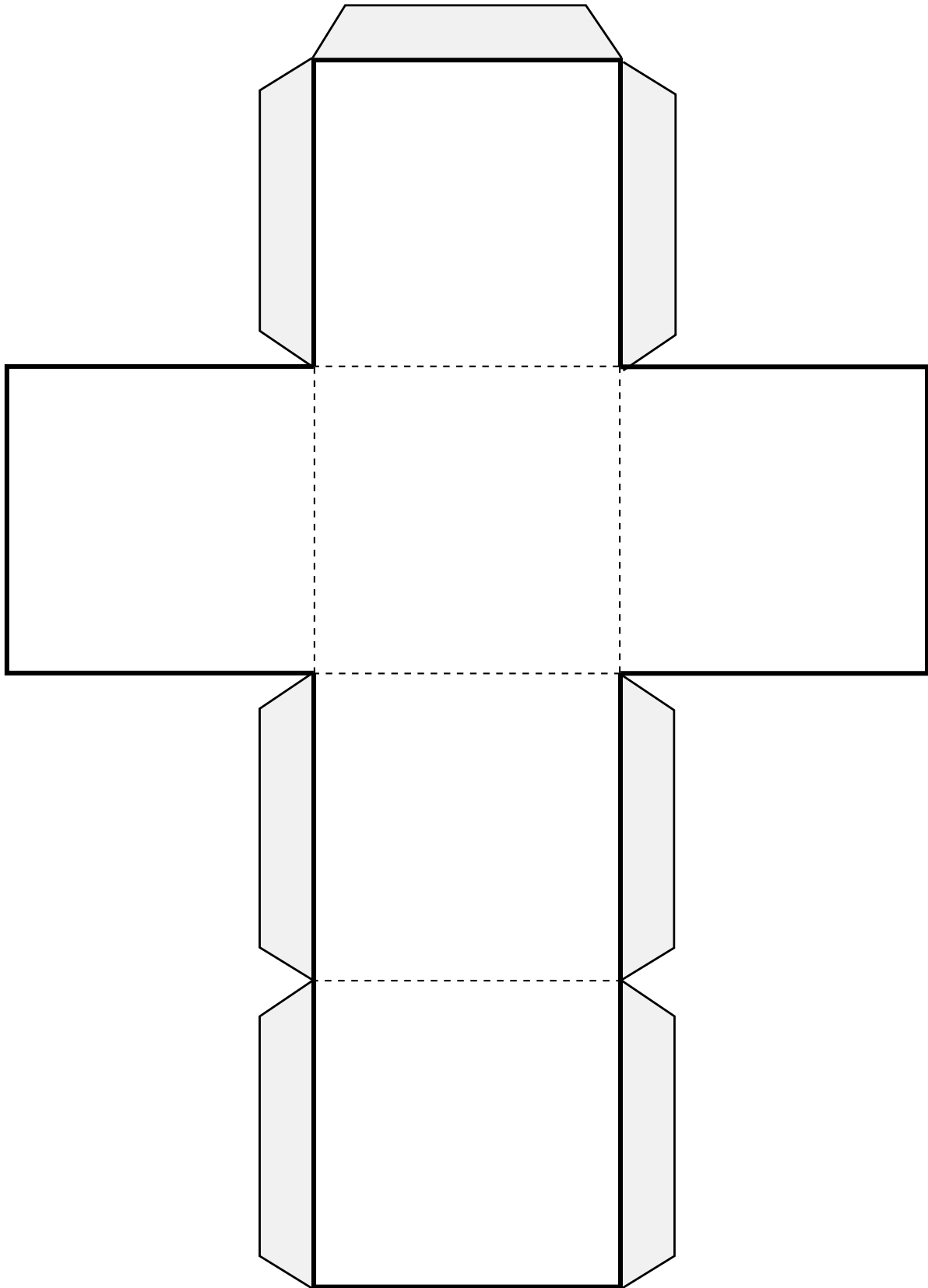

# Prisme à base rectangulaire

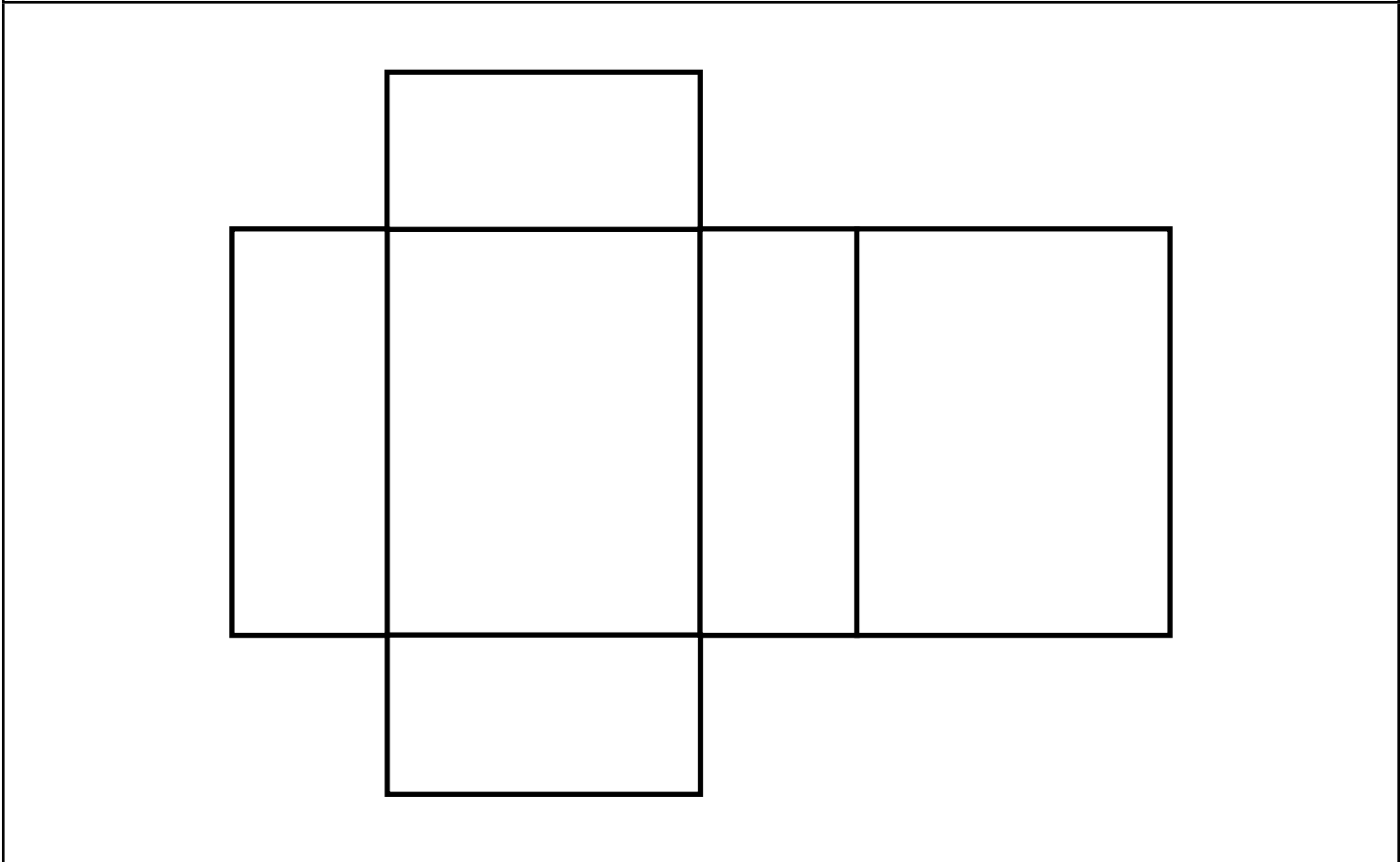
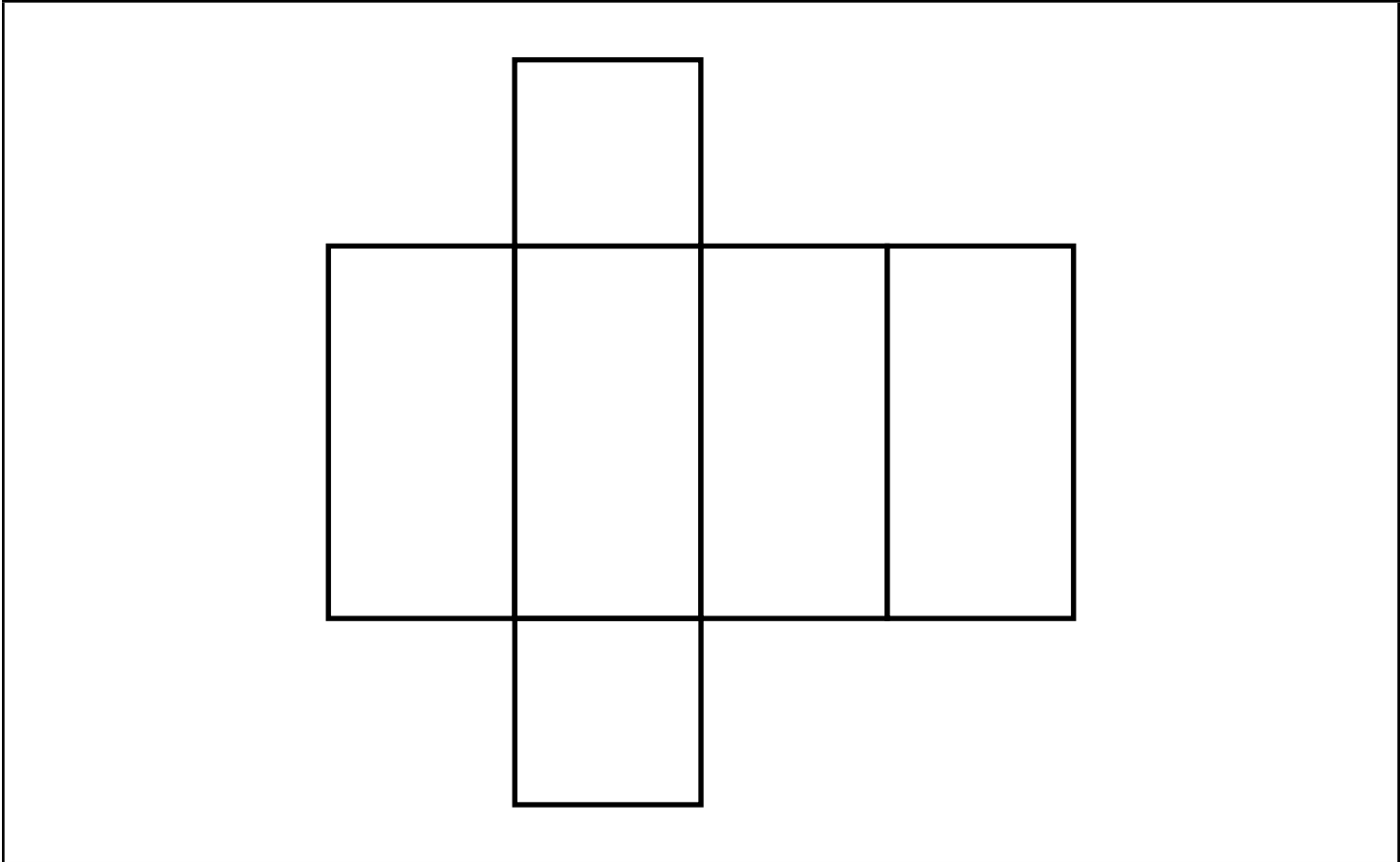



# Prisme à base rectangulaire

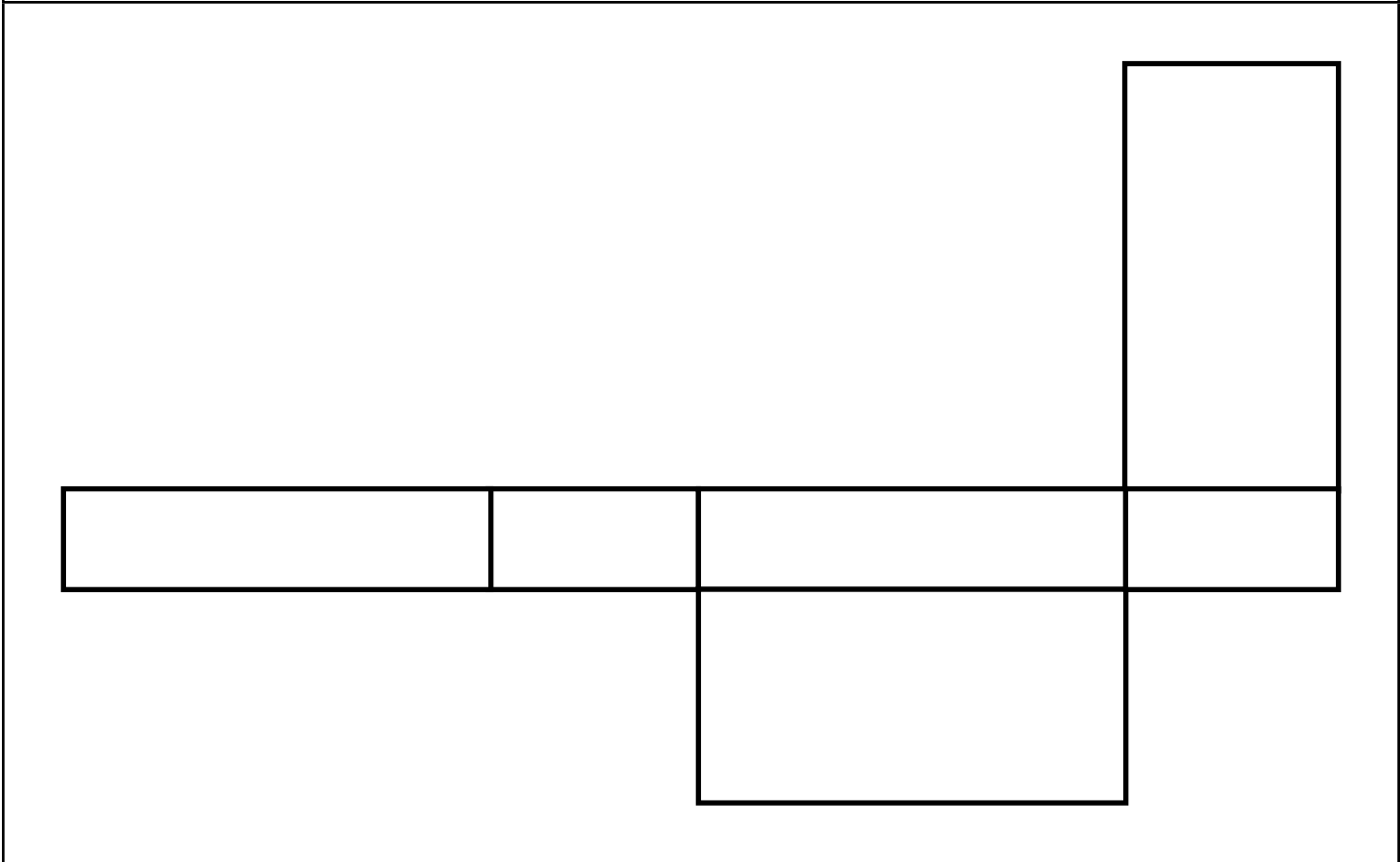
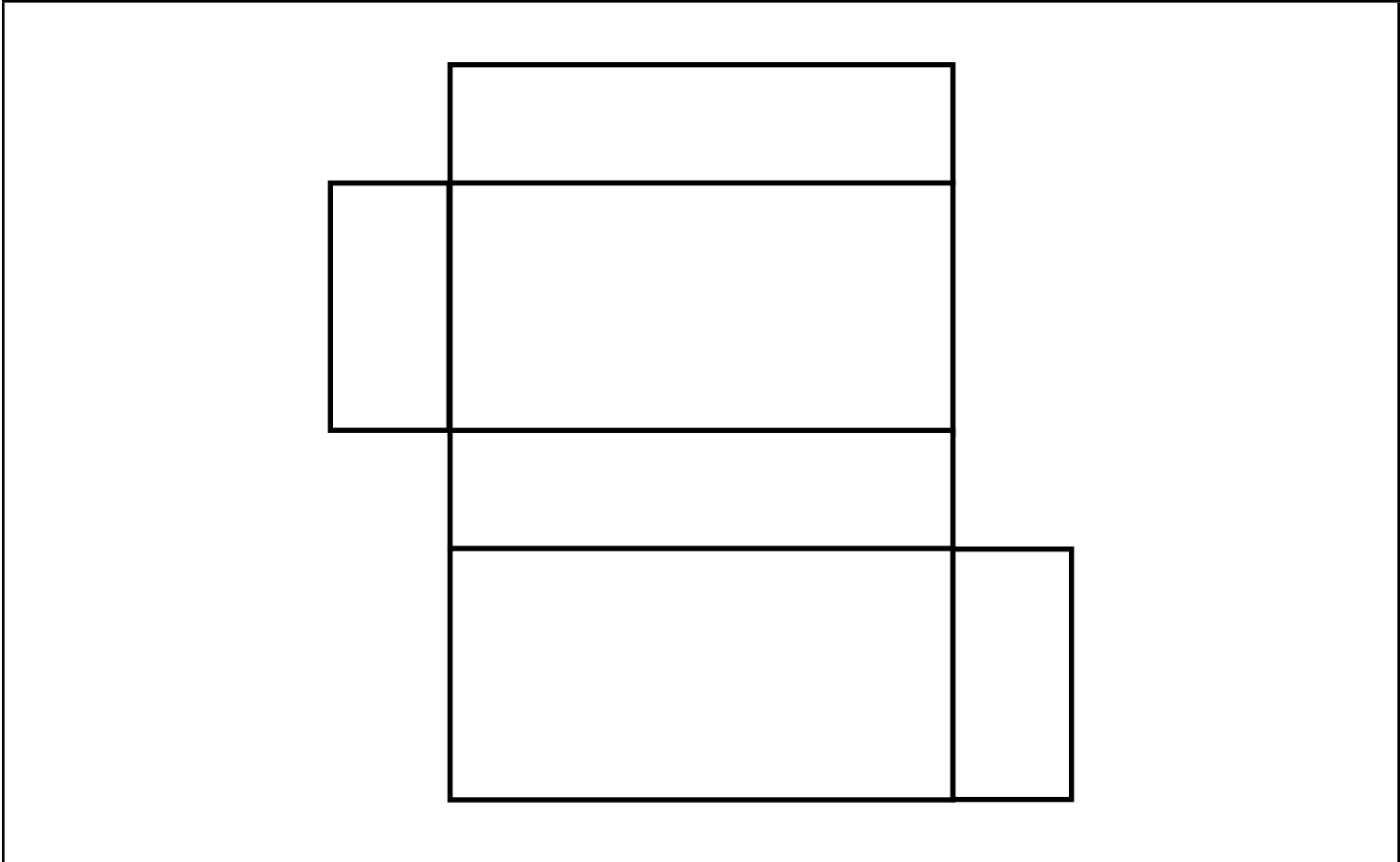

# Prisme à base rectangulaire

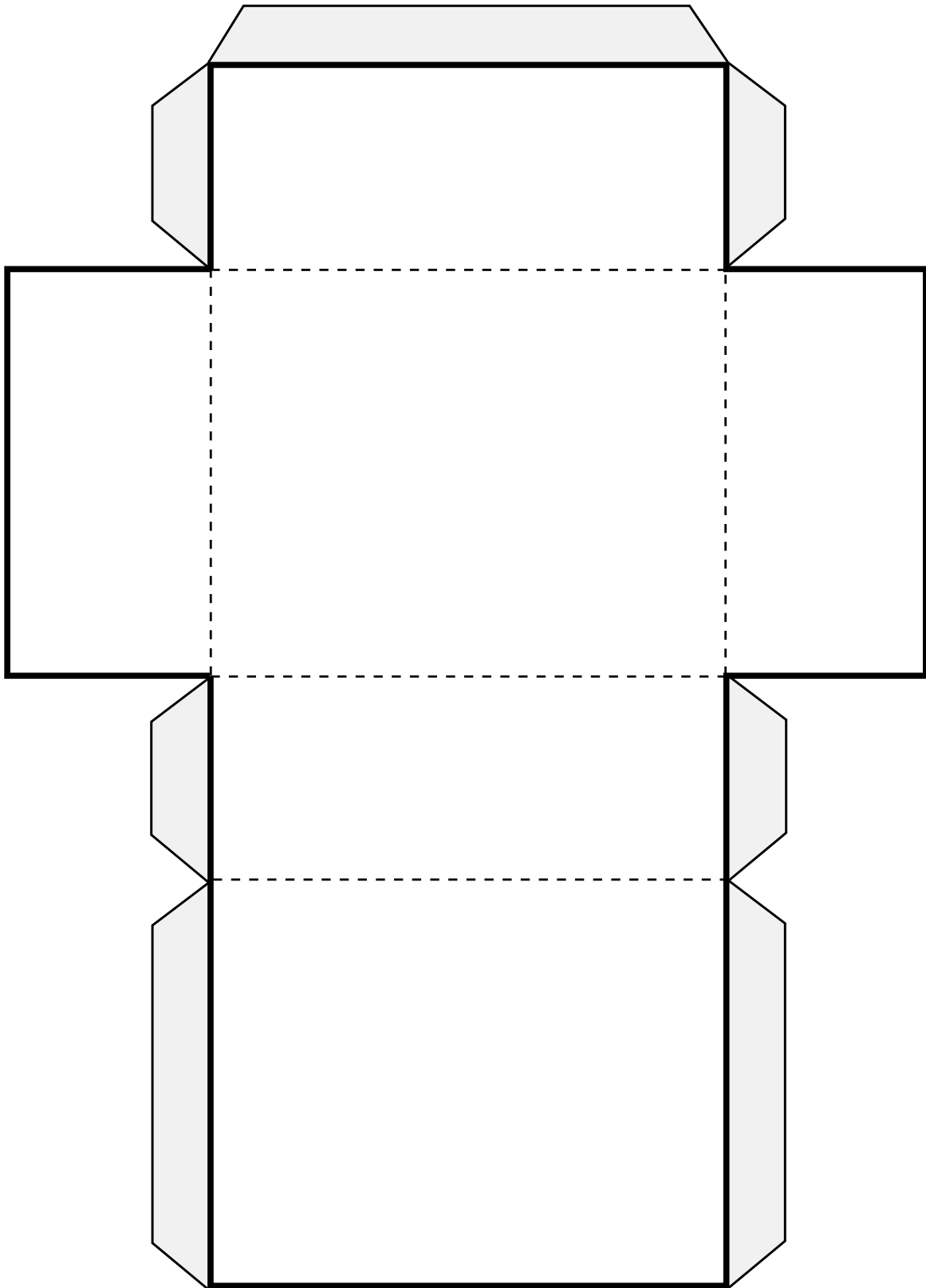

# Prisme à base triangulaire

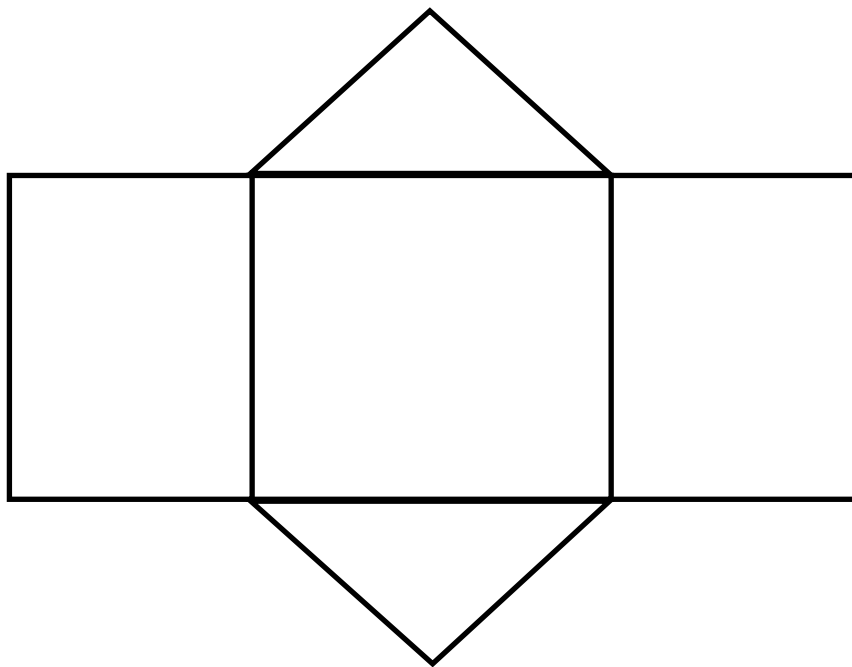
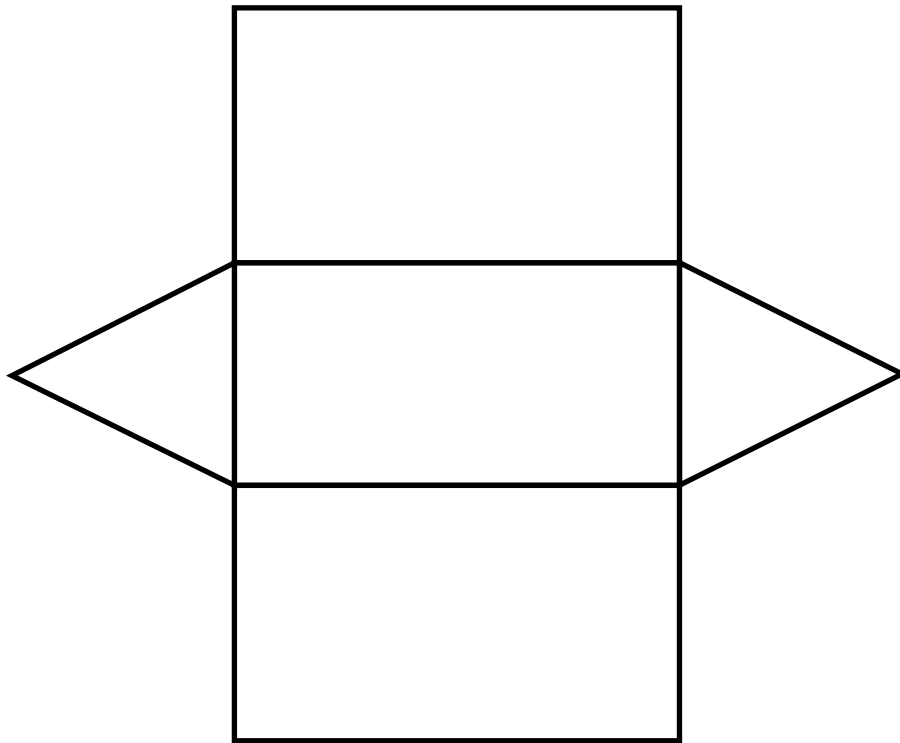

# Prisme à base triangulaire

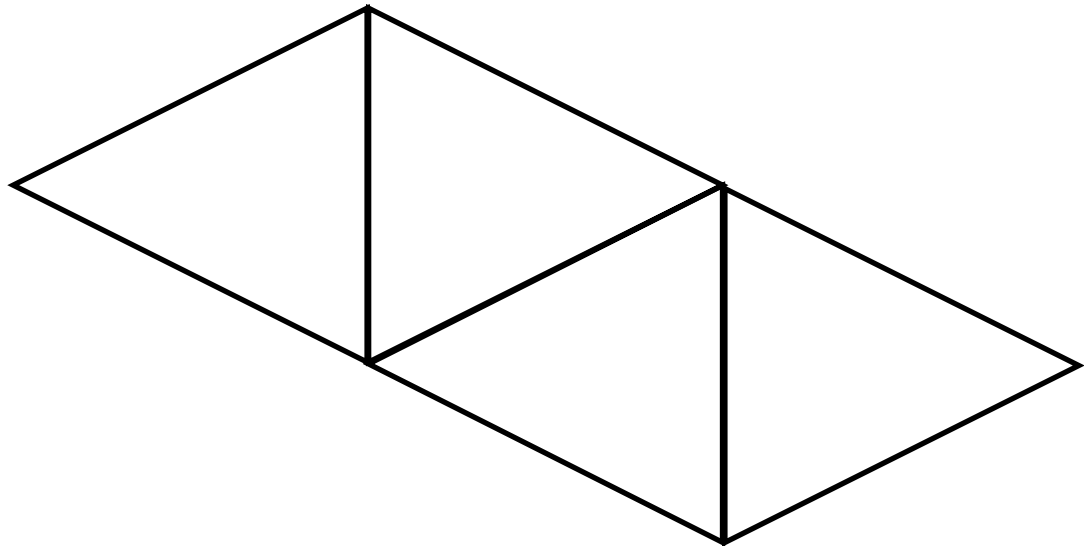
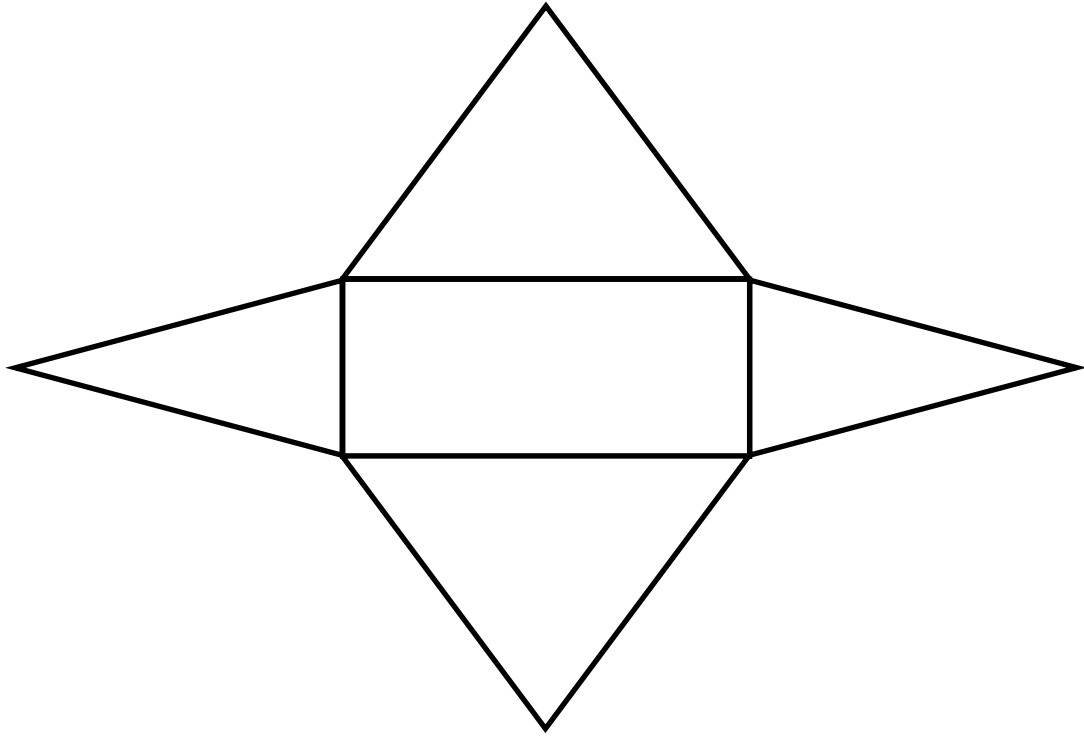

# Prisme à base triangulaire

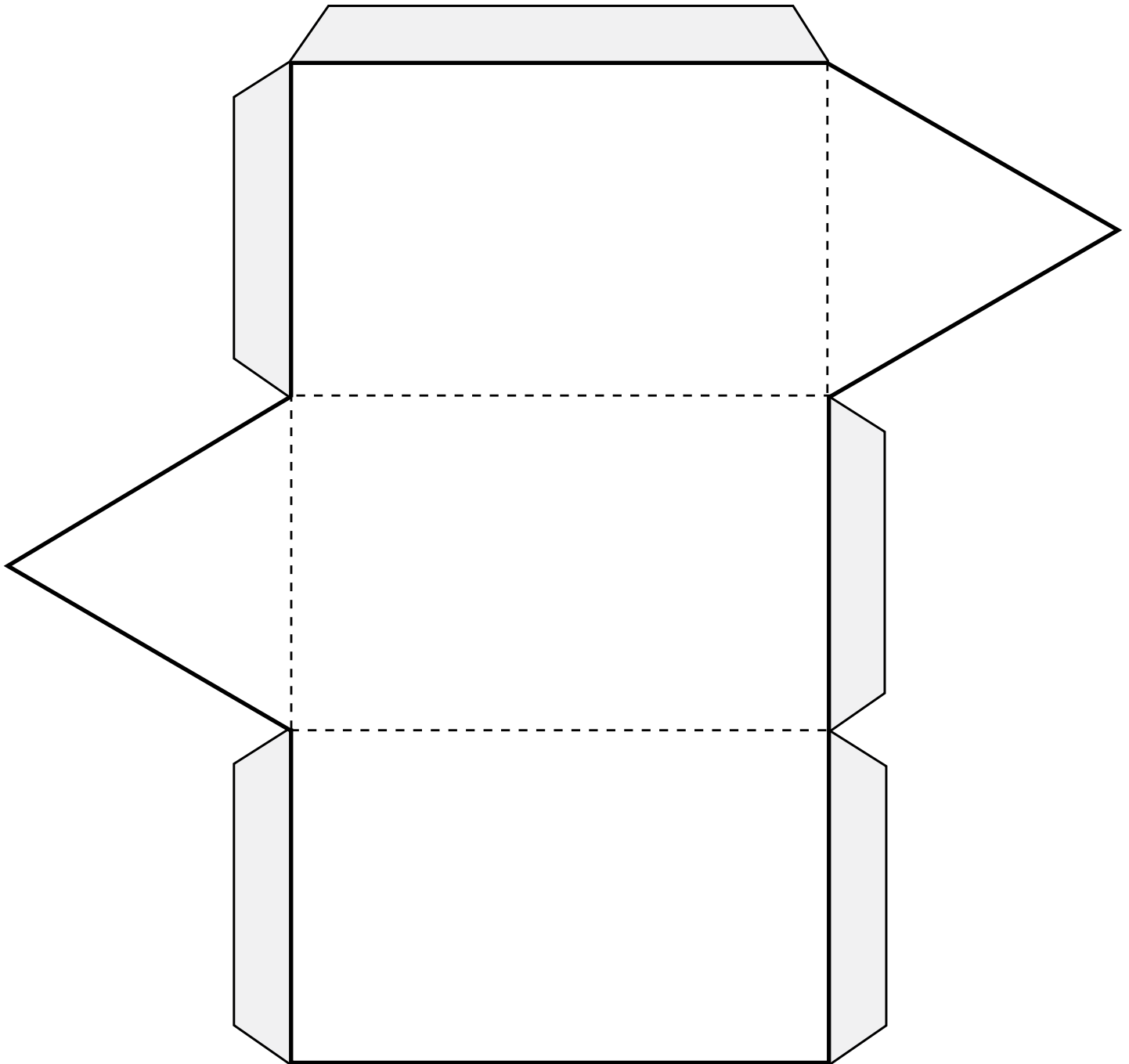

# Droites numériques (horizontales)

0 à 100 avec graduations accentuées et chacun des nombres de 0 à 100

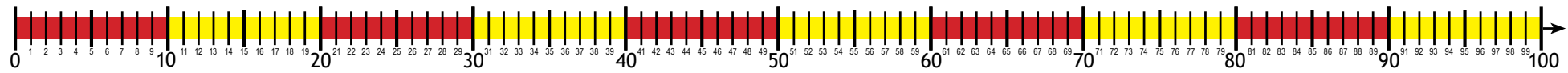
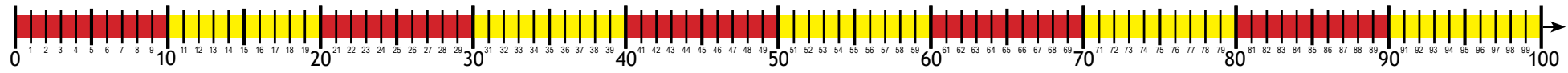
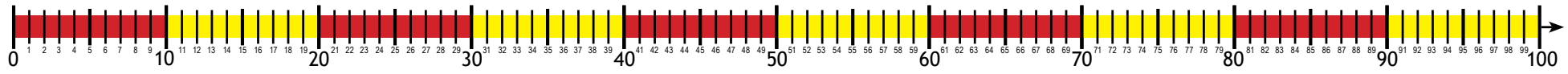

# Droites numériques (horizontales)

0 à 100 avec graduations accentuées et nombres montrant les multiples de 10

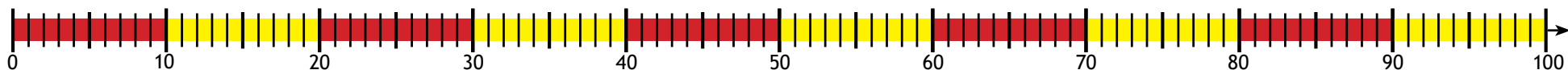
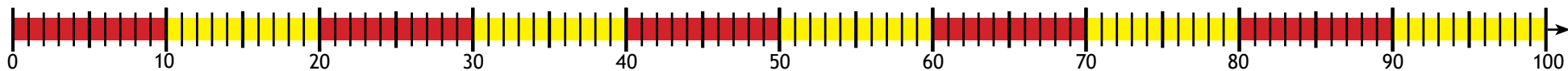
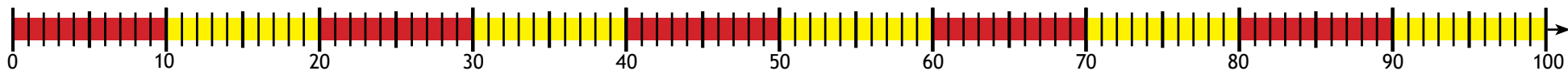

# Droites numériques (horizontales)

vide avec graduations accentuées





# Droites numériques (horizontales)

vide avec nombre réduit de graduations accentuées



# Droites numériques (horizontales) ouverte

Table des matières



Liste FR

Ma boîte à outils en mathématiques



284

|

# Droites numériques (horizontales) avec points de repère variés

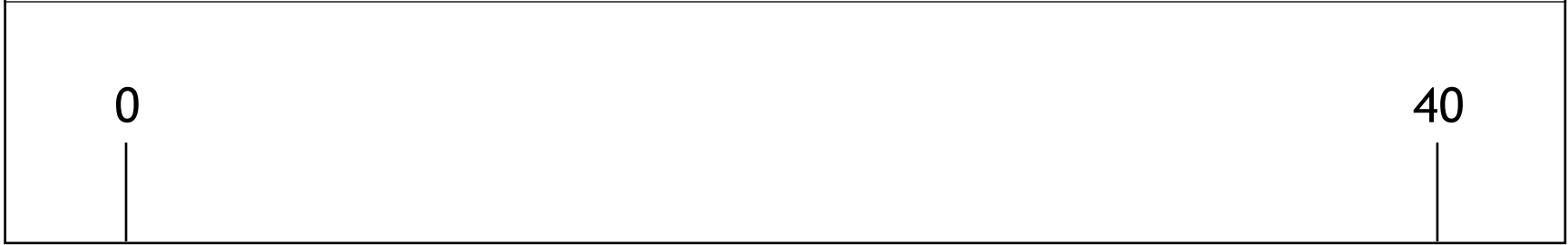
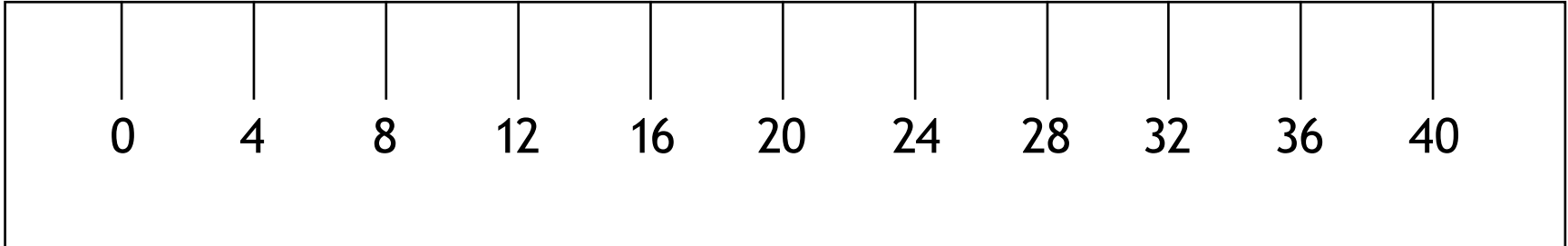

Replier

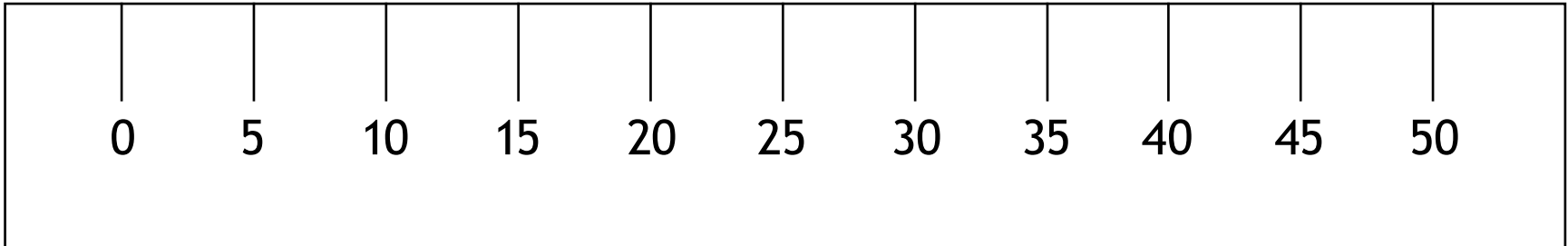

Replier





# Droites numériques (horizontales) avec points de repère variés

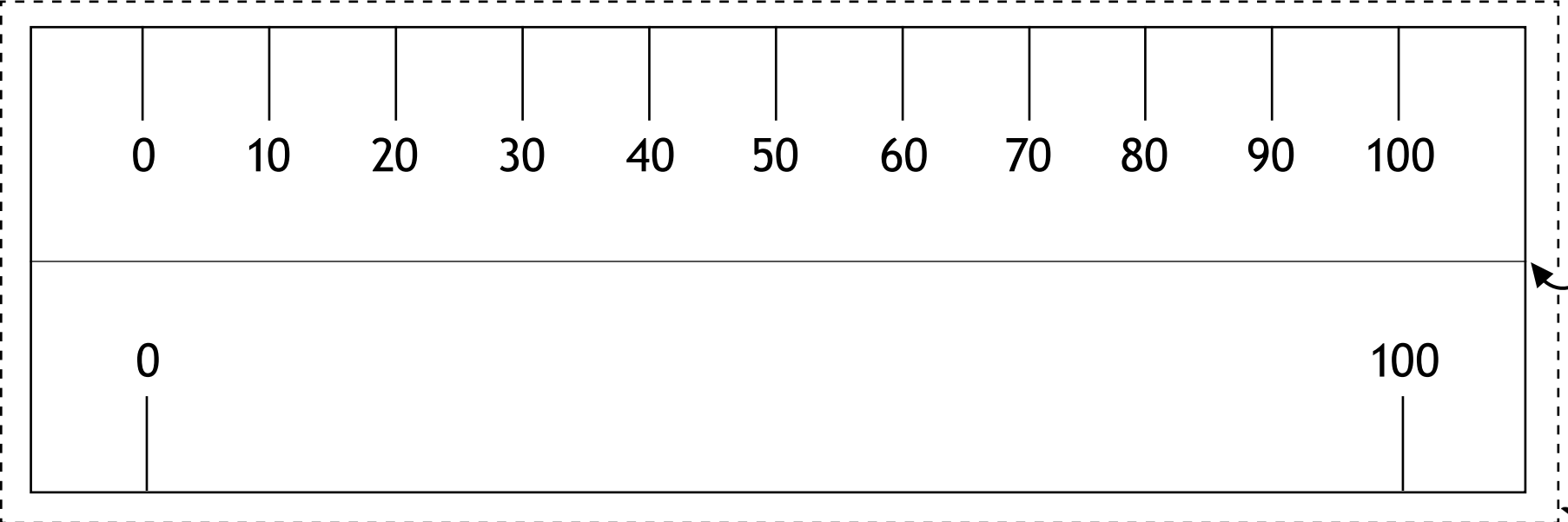

Replier

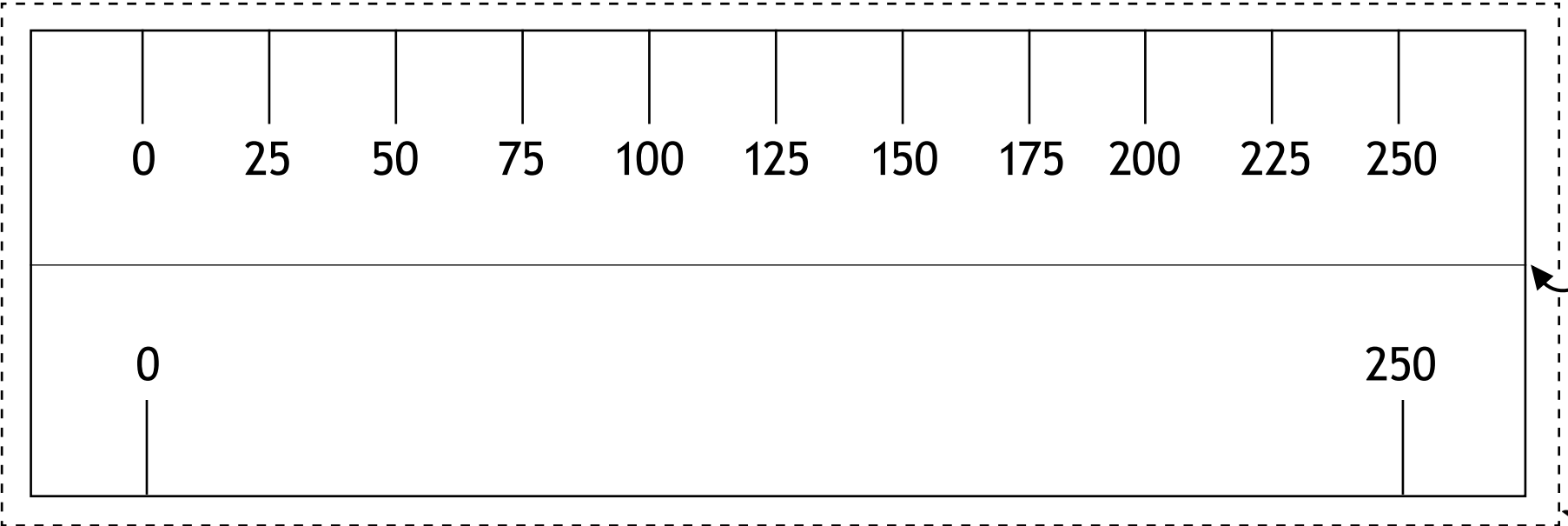

Replier

# Droites numériques (horizontales)

avec points de repère variés

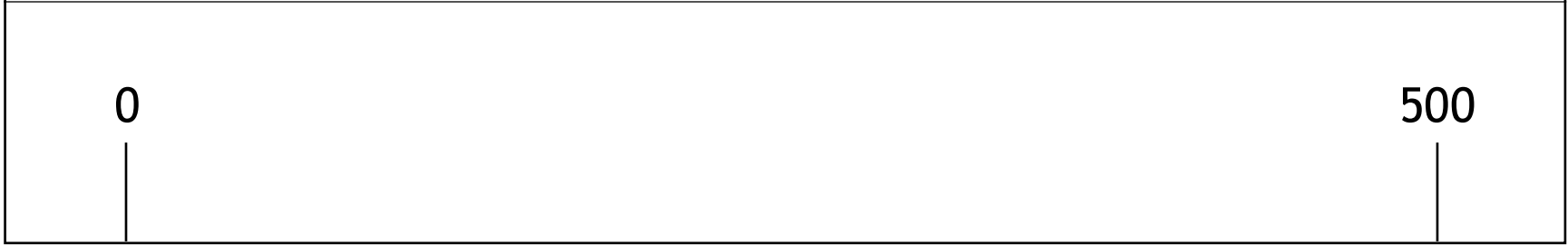
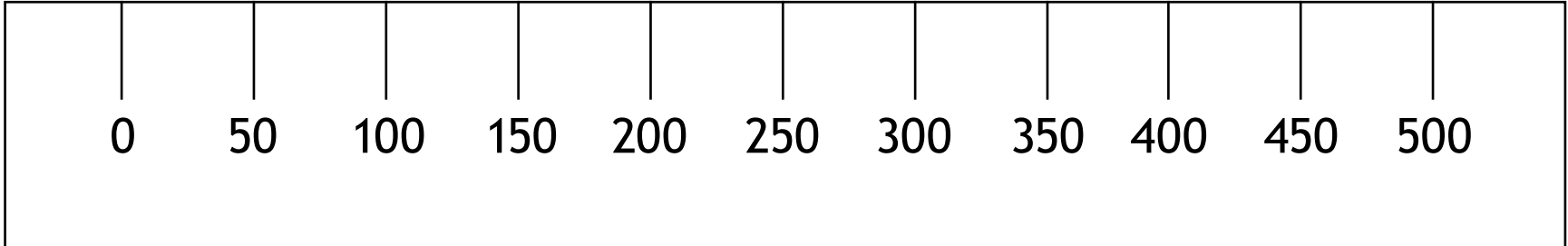

Replier

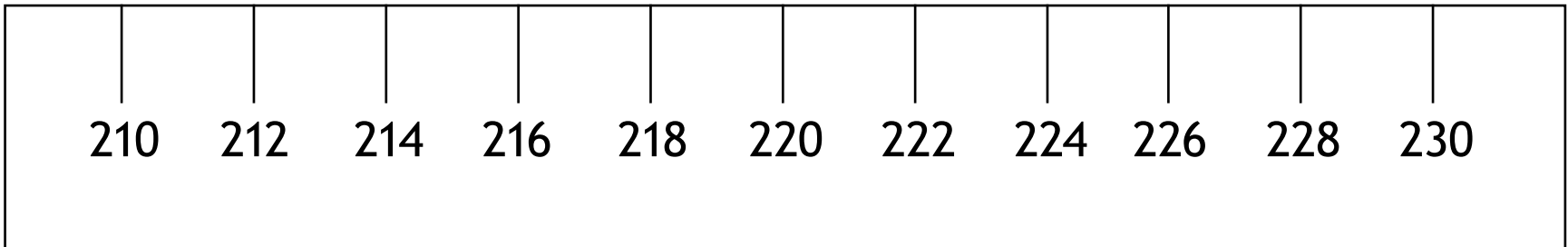

Replier



# Droites numériques (horizontales) vides



Top numerical line template. It consists of a horizontal line with 12 vertical tick marks above it. Below the horizontal line is a large empty rectangular area for writing. A dashed line is positioned above the template, and a dashed line is positioned below it.

Replier



Bottom numerical line template. It consists of a horizontal line with 12 vertical tick marks above it. Below the horizontal line is a large empty rectangular area for writing. A dashed line is positioned above the template, and a dashed line is positioned below it.

Replier



# Droites numériques (verticale)

0 à 100 avec graduations accentuées et chacun des nombres de 0 à 100

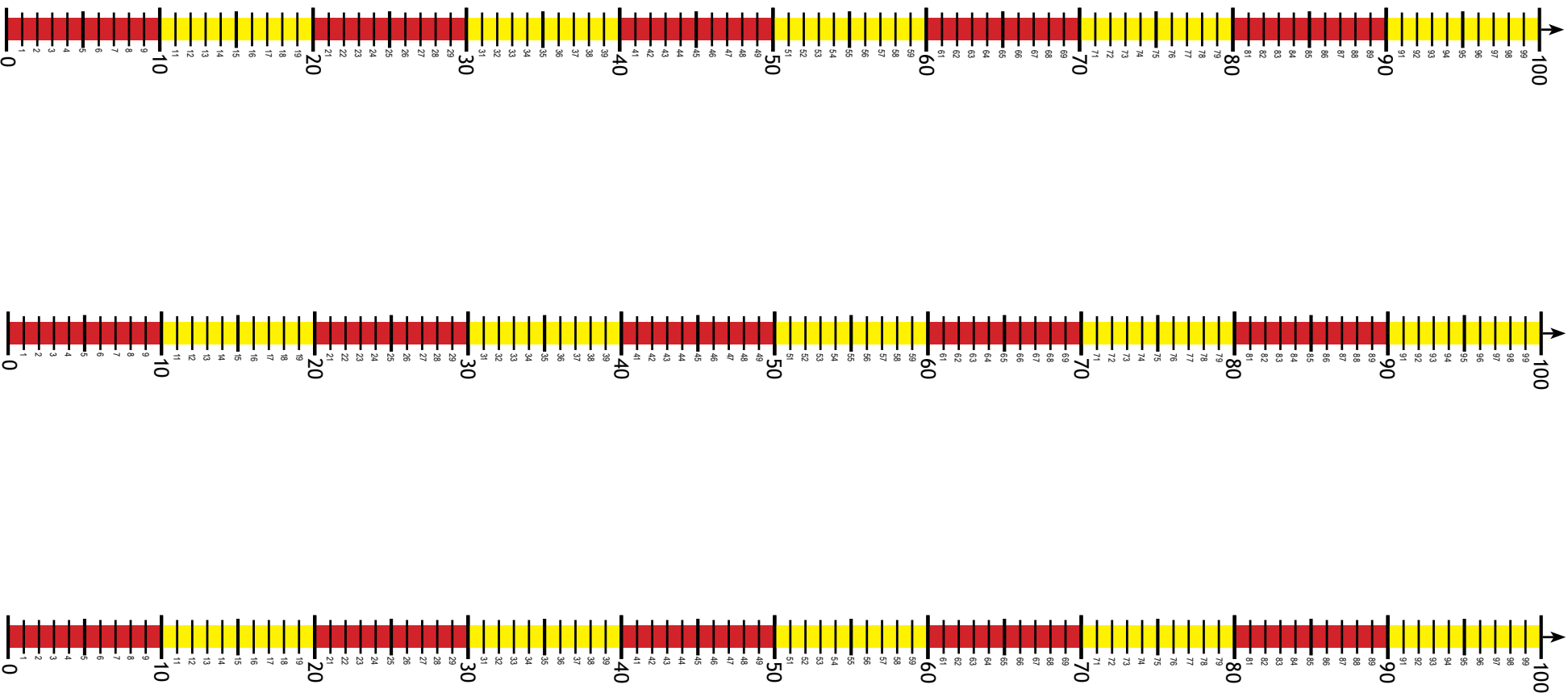

# Droites numériques (verticales)

0 à 100 avec graduations accentuées et nombres montrant les multiples de 10

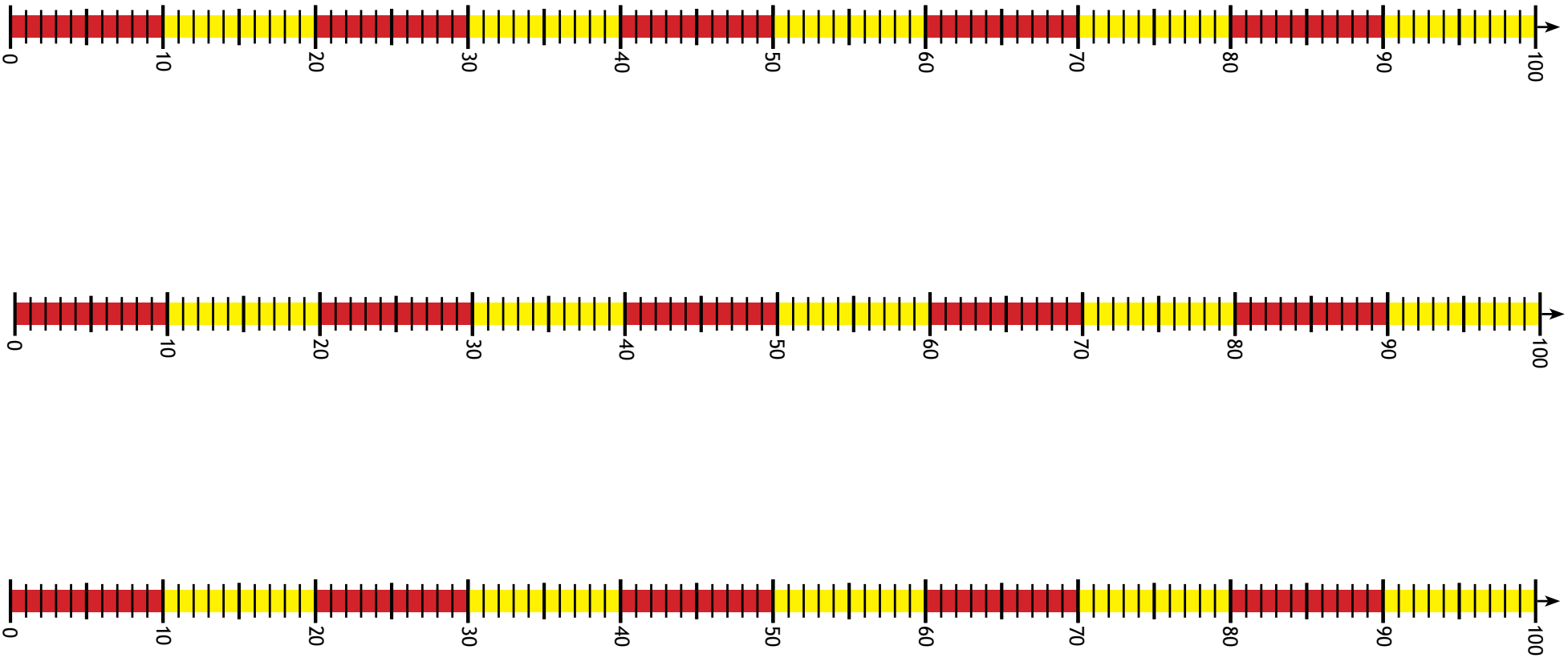



# Droites numériques (verticales)

vide avec graduations accentuées



# Droites numériques (verticales)

vide avec nombre réduit de graduations accentuées



# Droites numériques (verticales) ouverte

Table des matières



Ma boîte à outils en mathématiques



293

Liste FR

# Ensemble de dominos (Total de points jusqu'à 12)

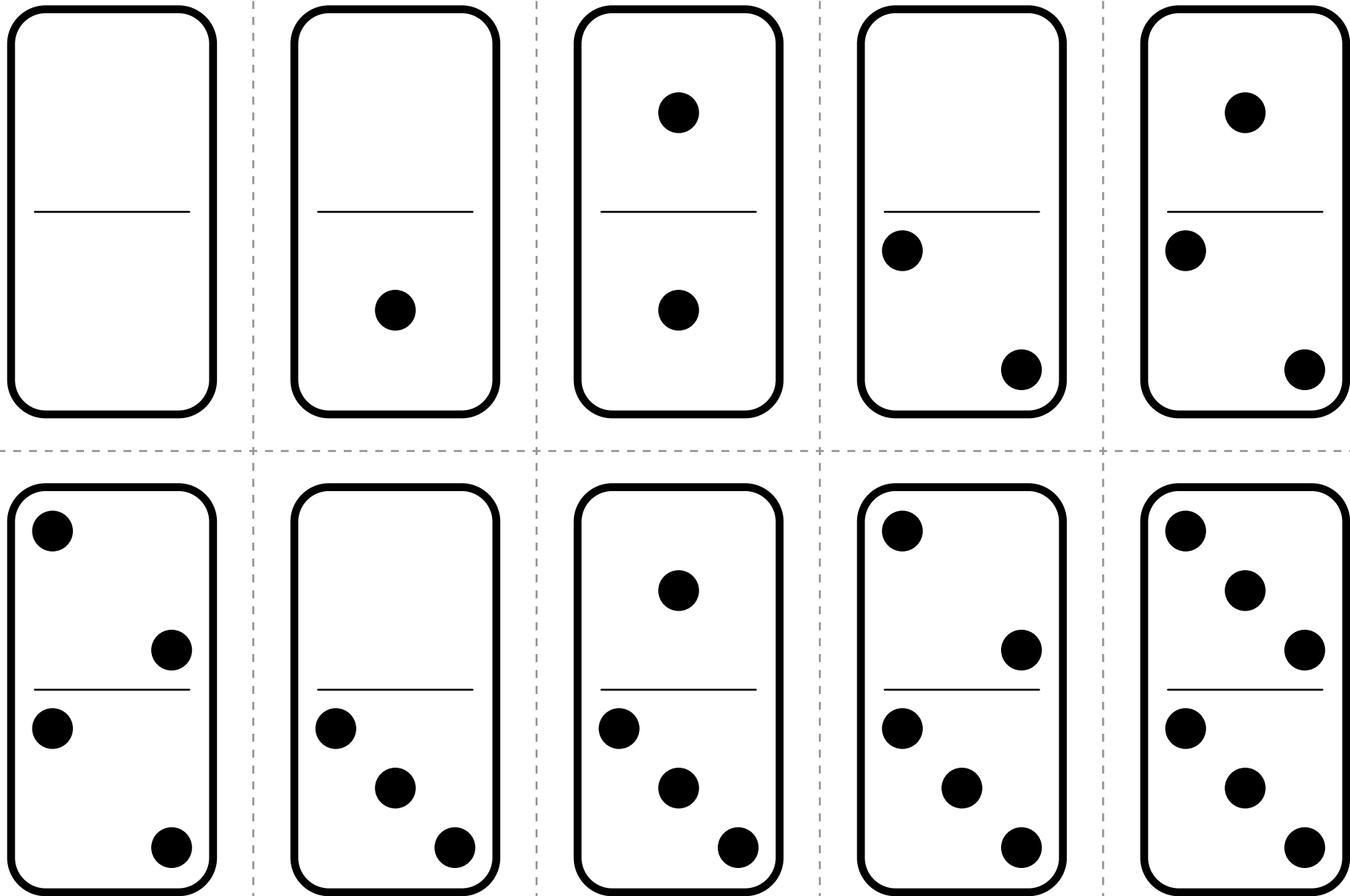

# Ensemble de dominos (Total de points jusqu'à 12) (suite)

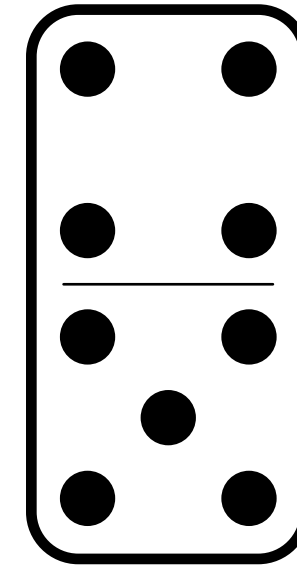
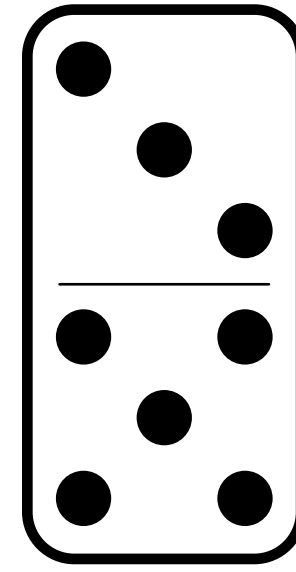
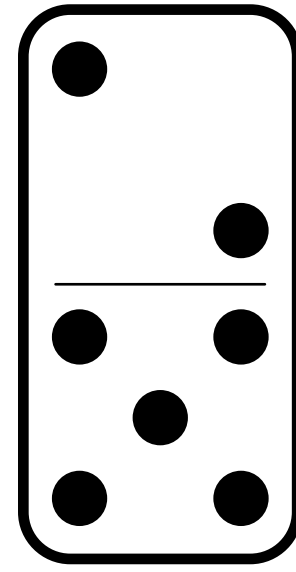
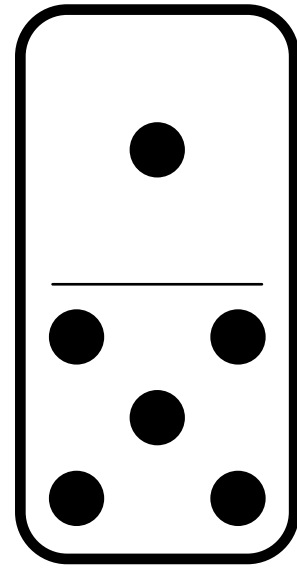
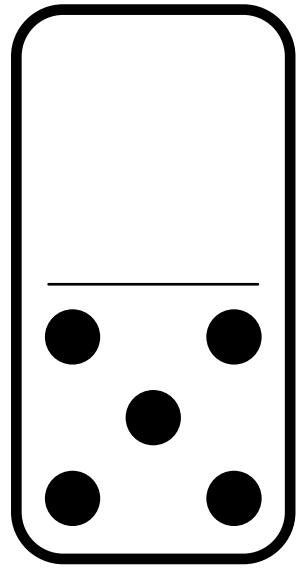
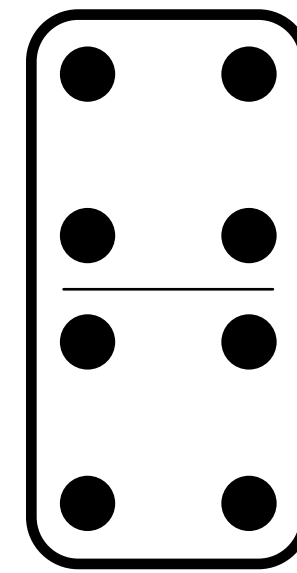
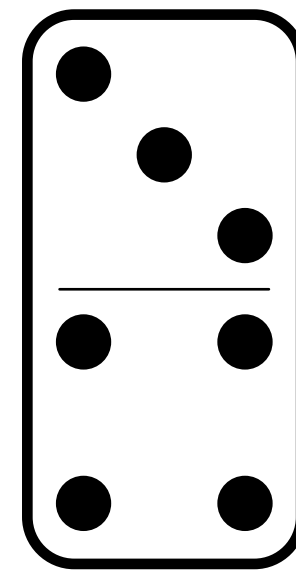
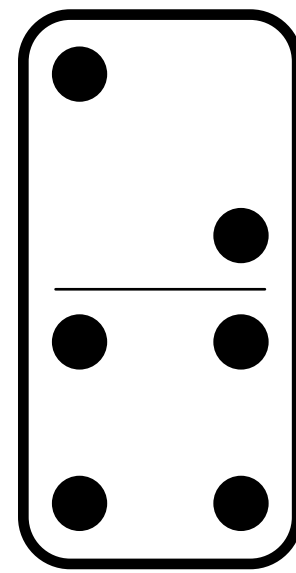
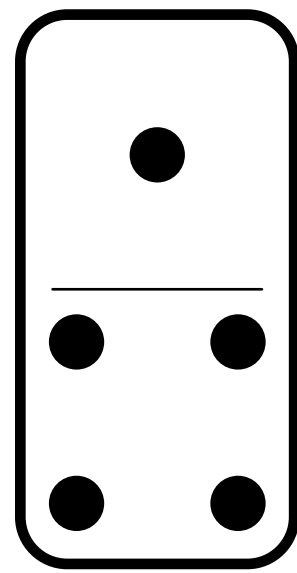
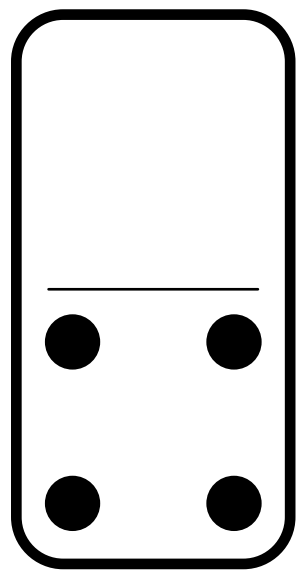

# Ensemble de dominos (Total de points jusqu'à 12) (suite)

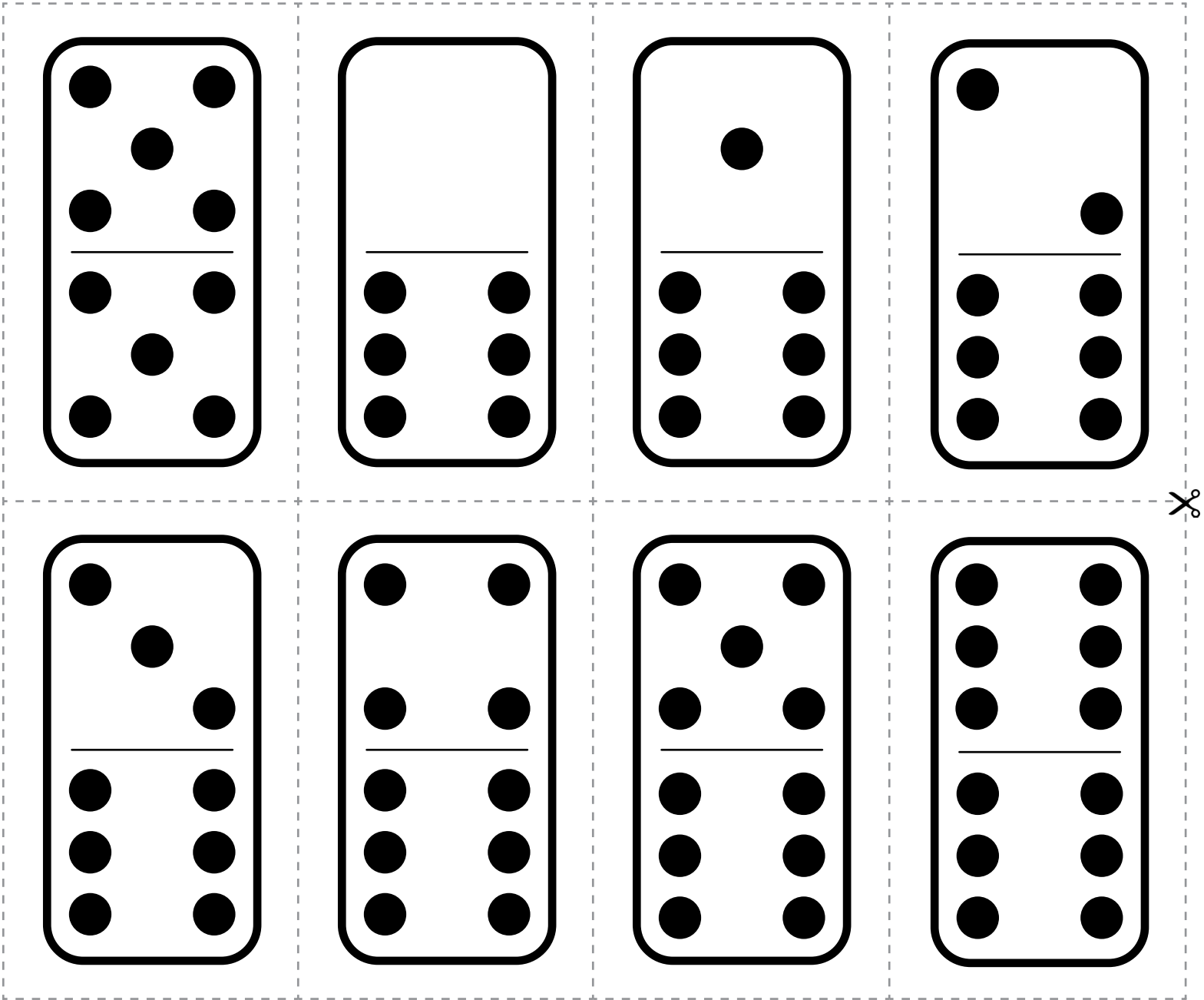

# Ensemble de polygones réguliers

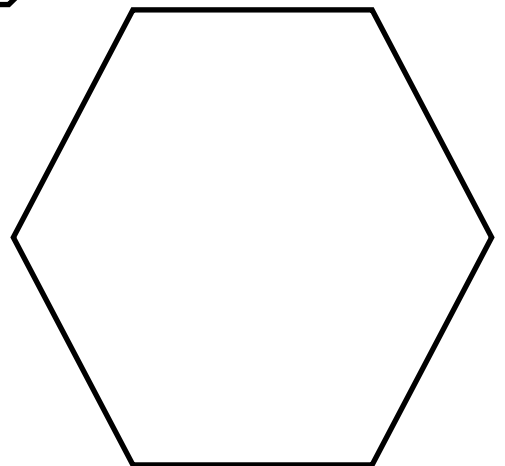
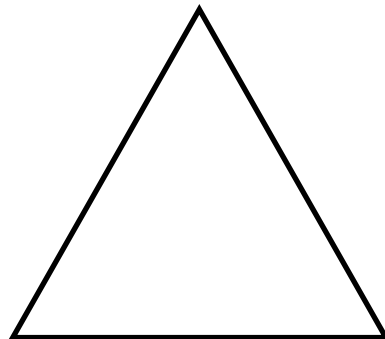
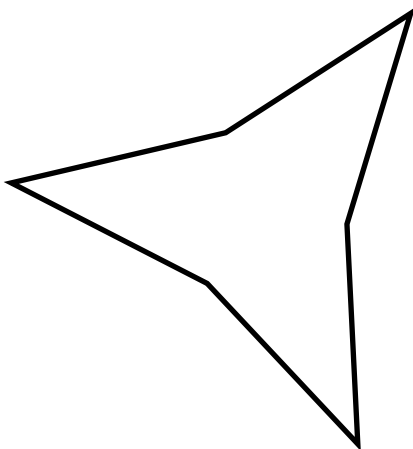
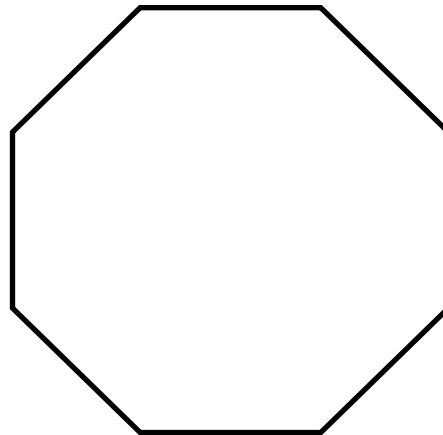
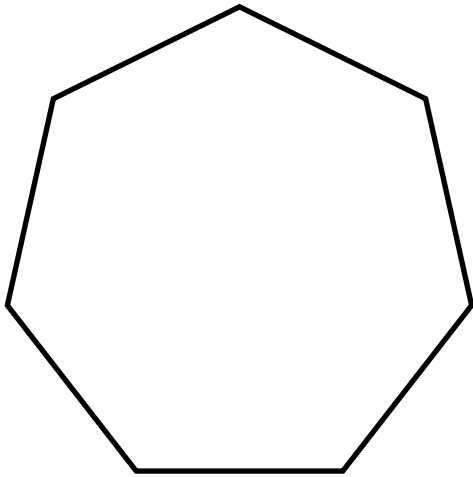
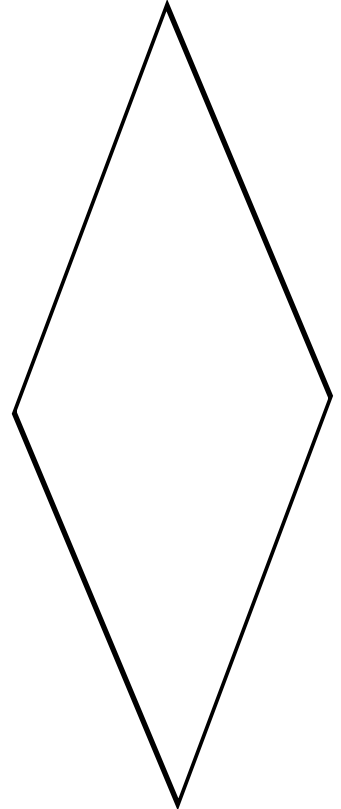
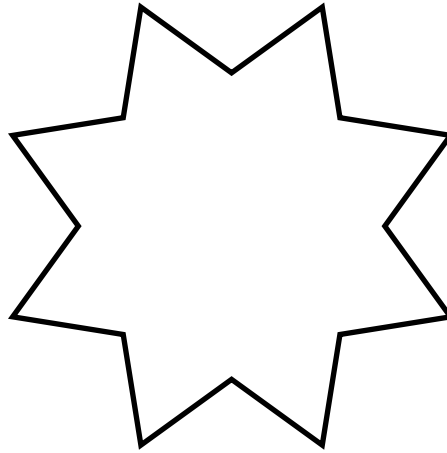
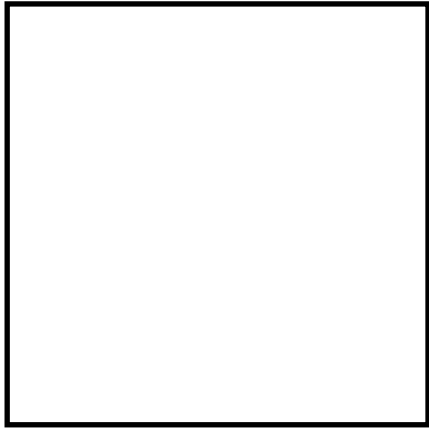

# Ensemble de polygones irréguliers

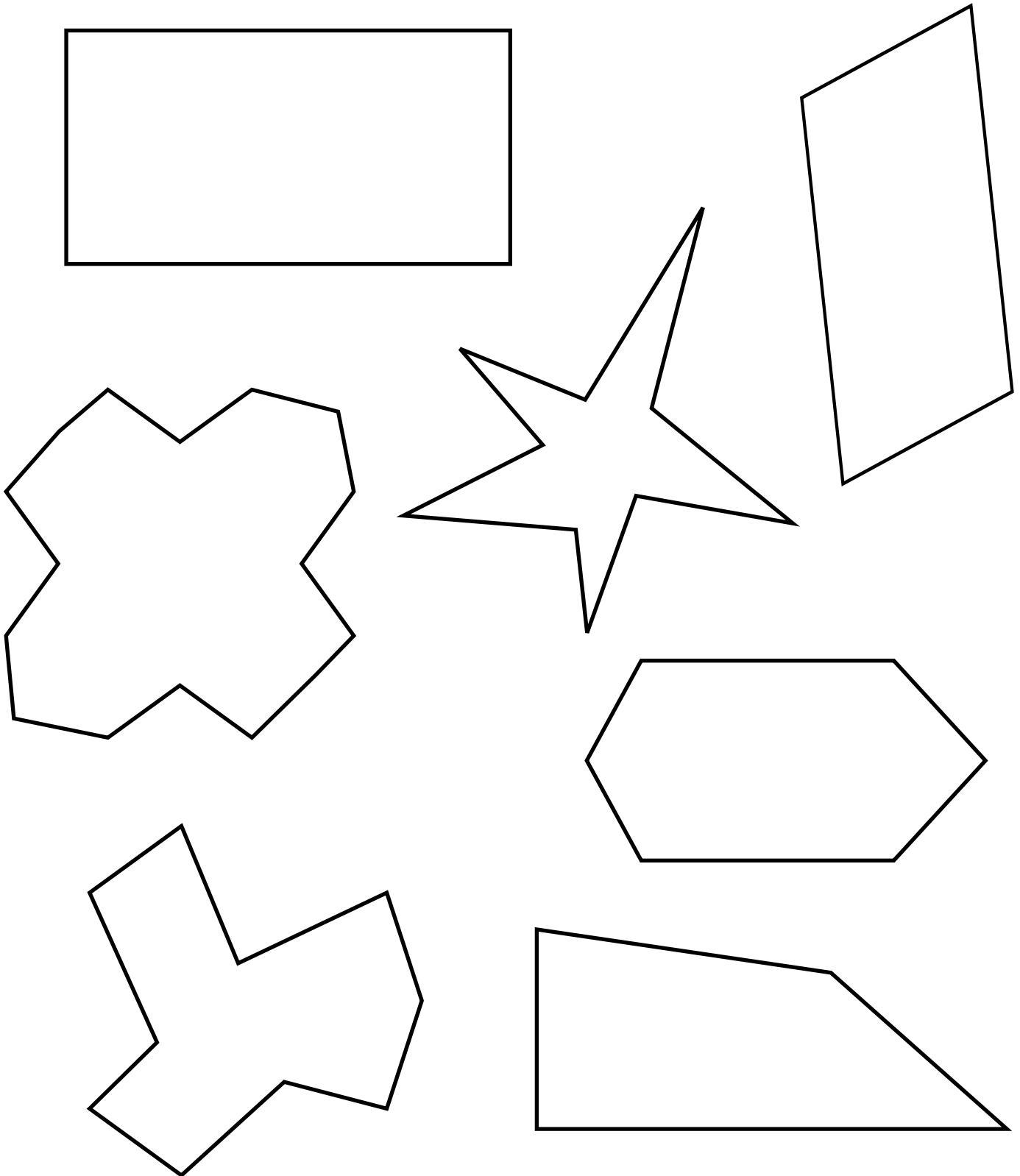



# Éventail (0 à 9) avec décimales

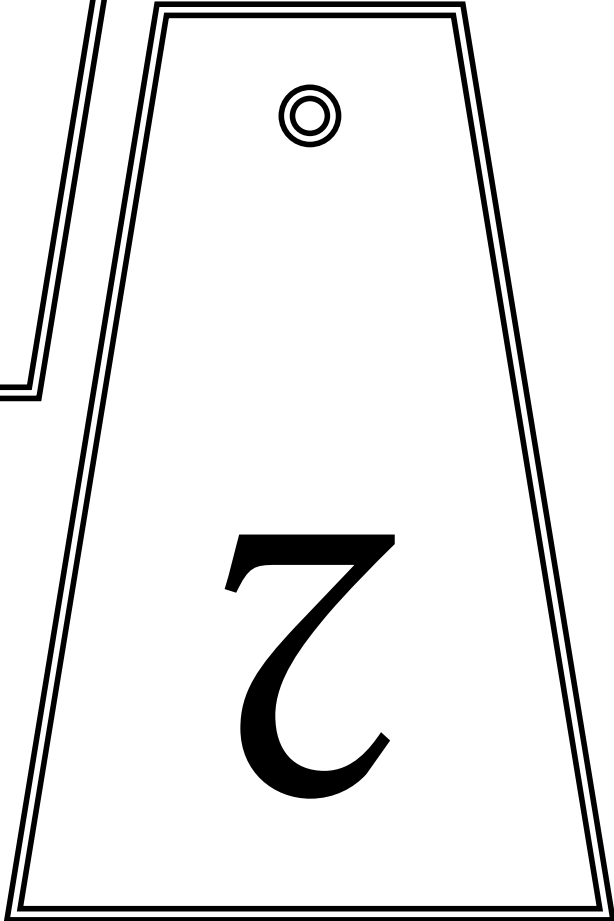
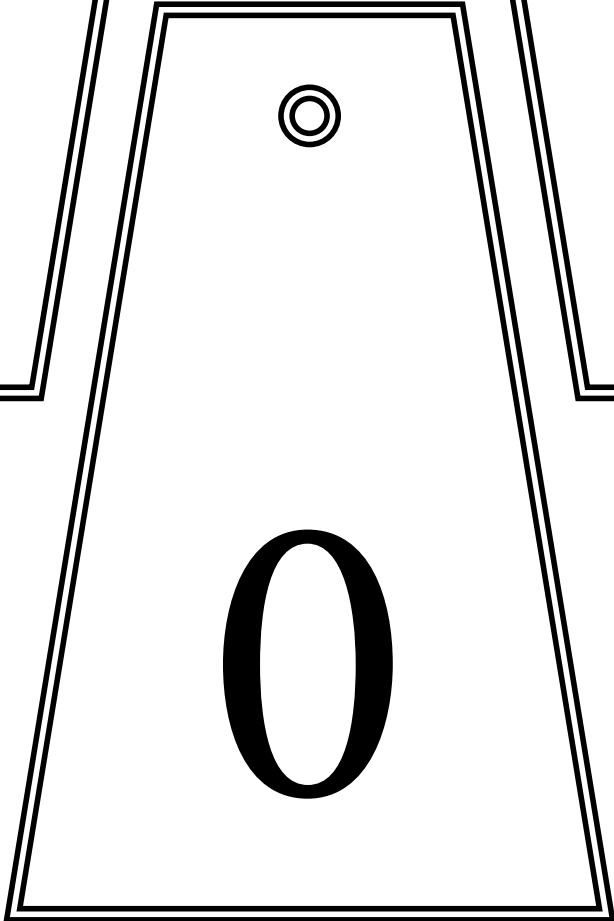
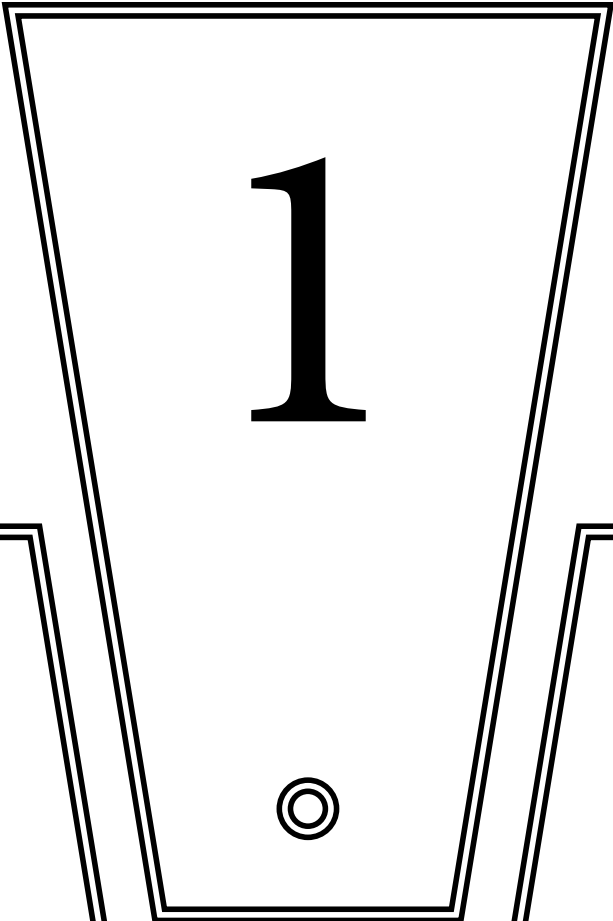
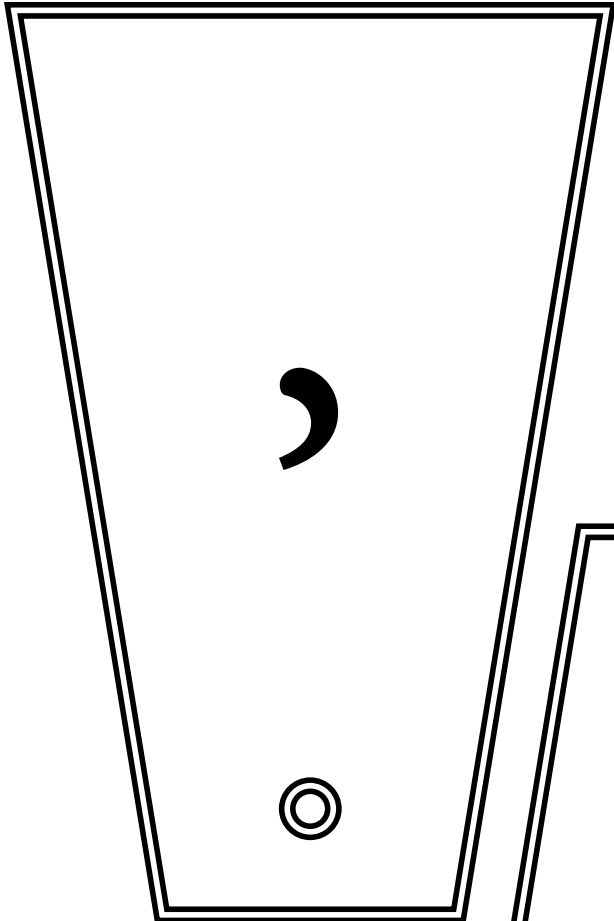

**Éventail (0 à 9)  
avec décimales  
(suite)**

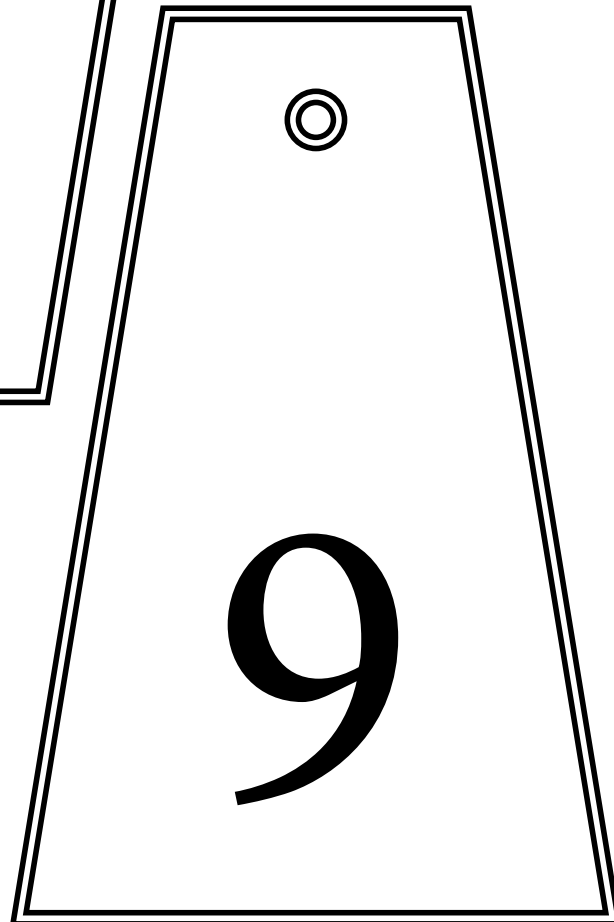
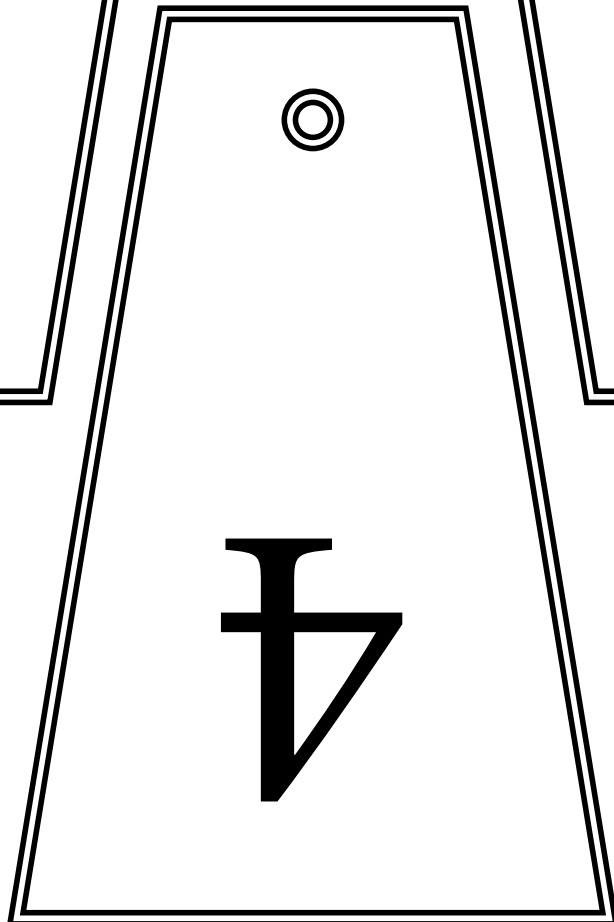
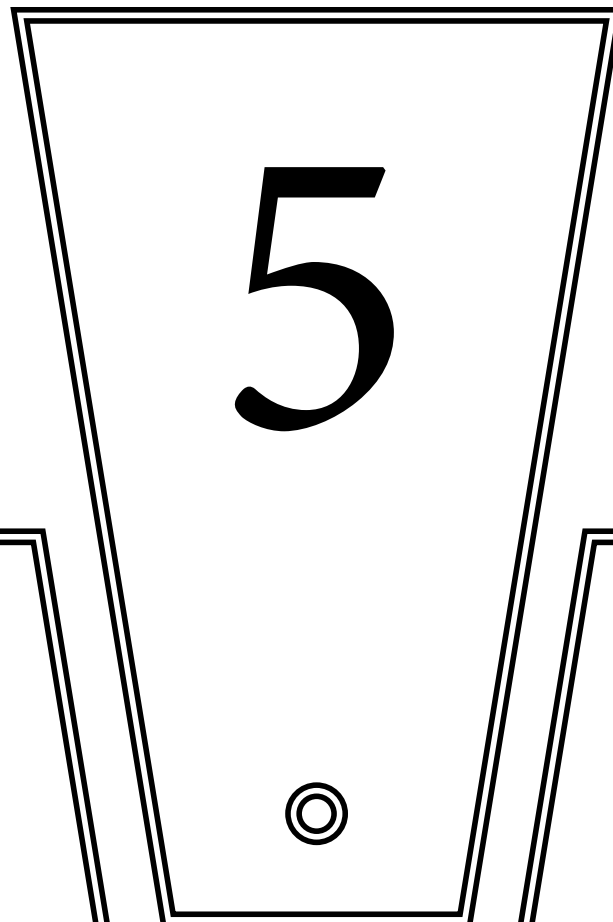
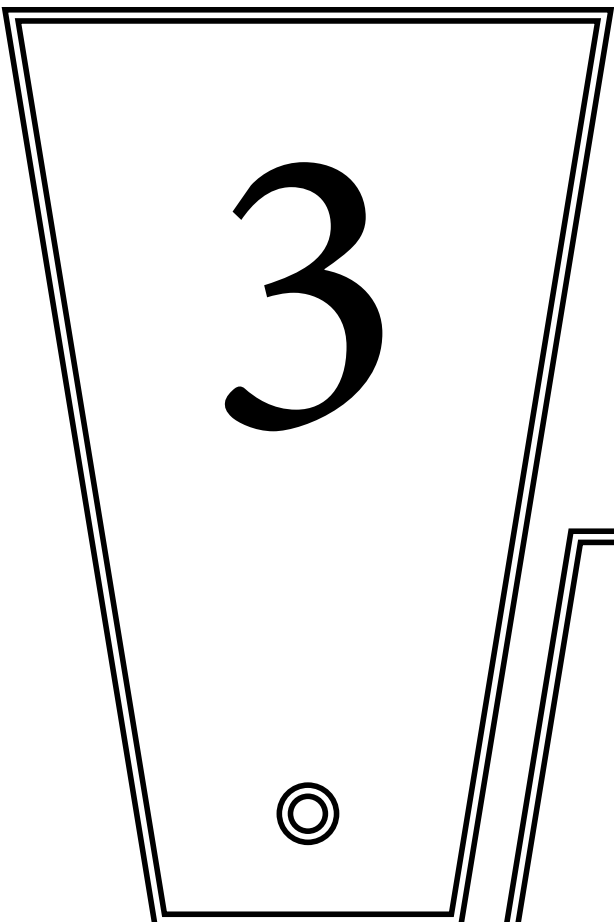

**Éventail (0 à 9)  
avec décimales**  
(suite)

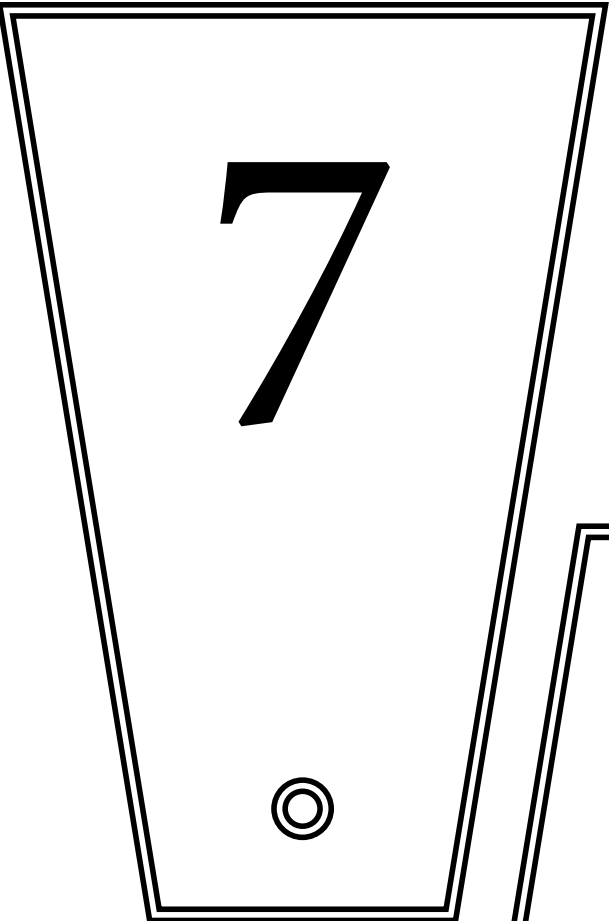
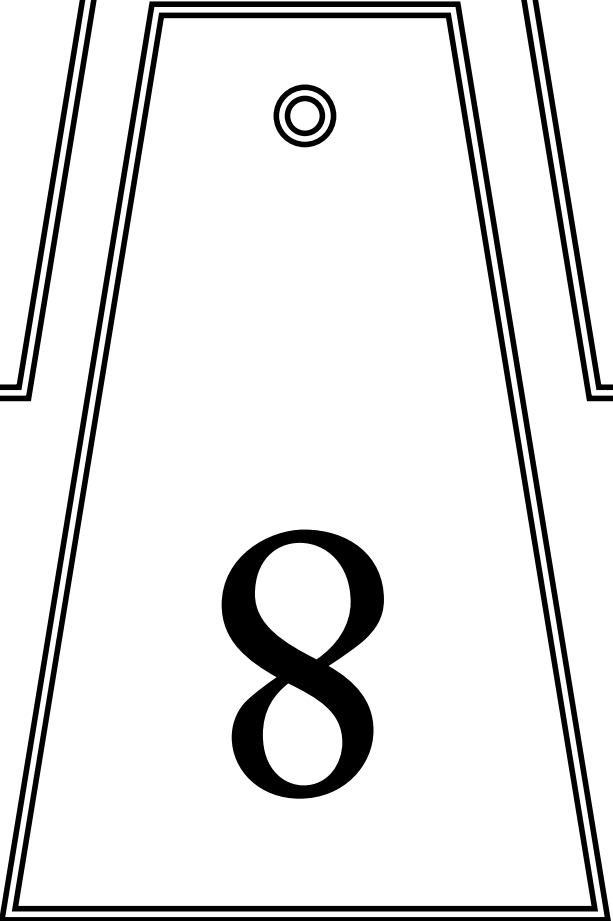
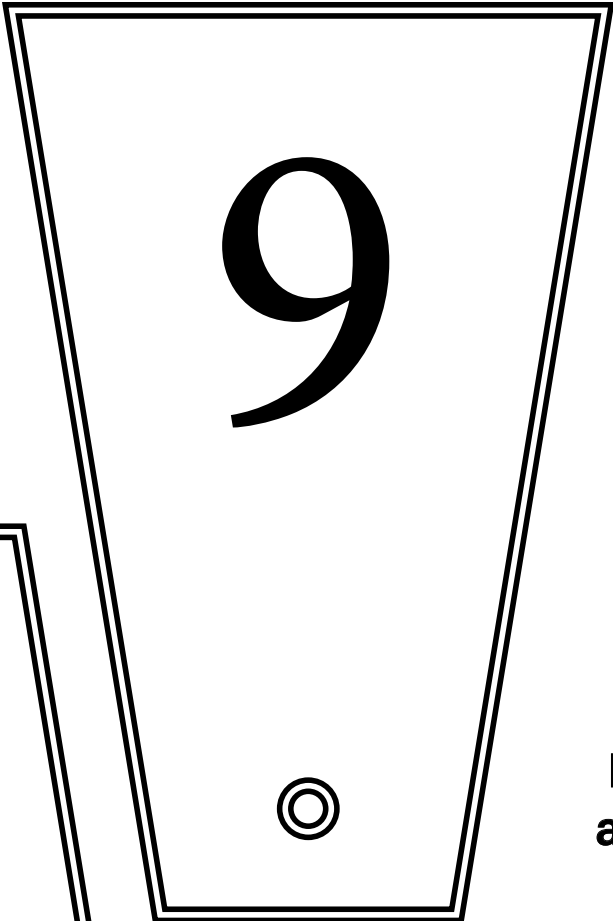

# Palette (0 à 9) avec décimales

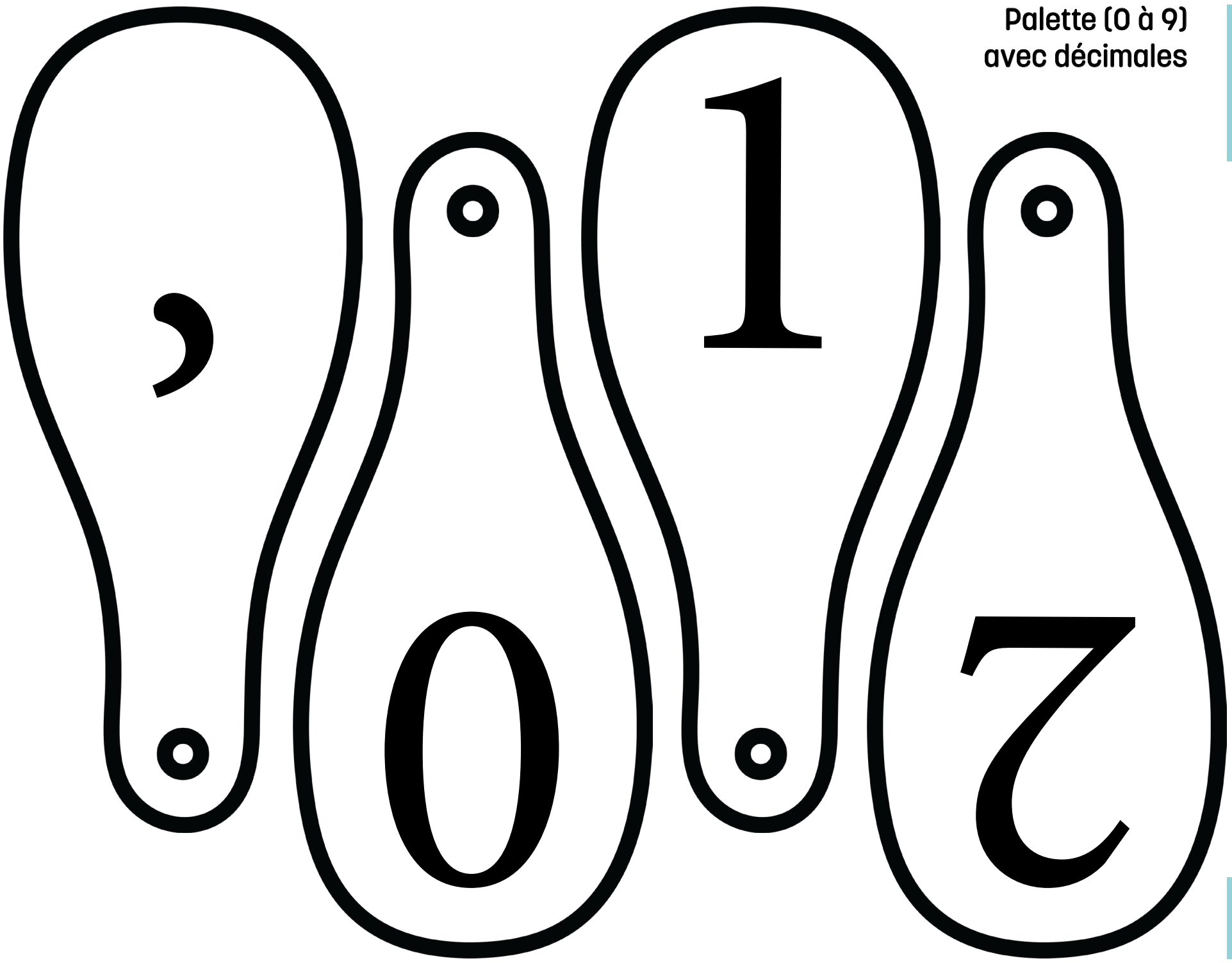

Palette (0 à 9)  
avec décimales  
(suite)

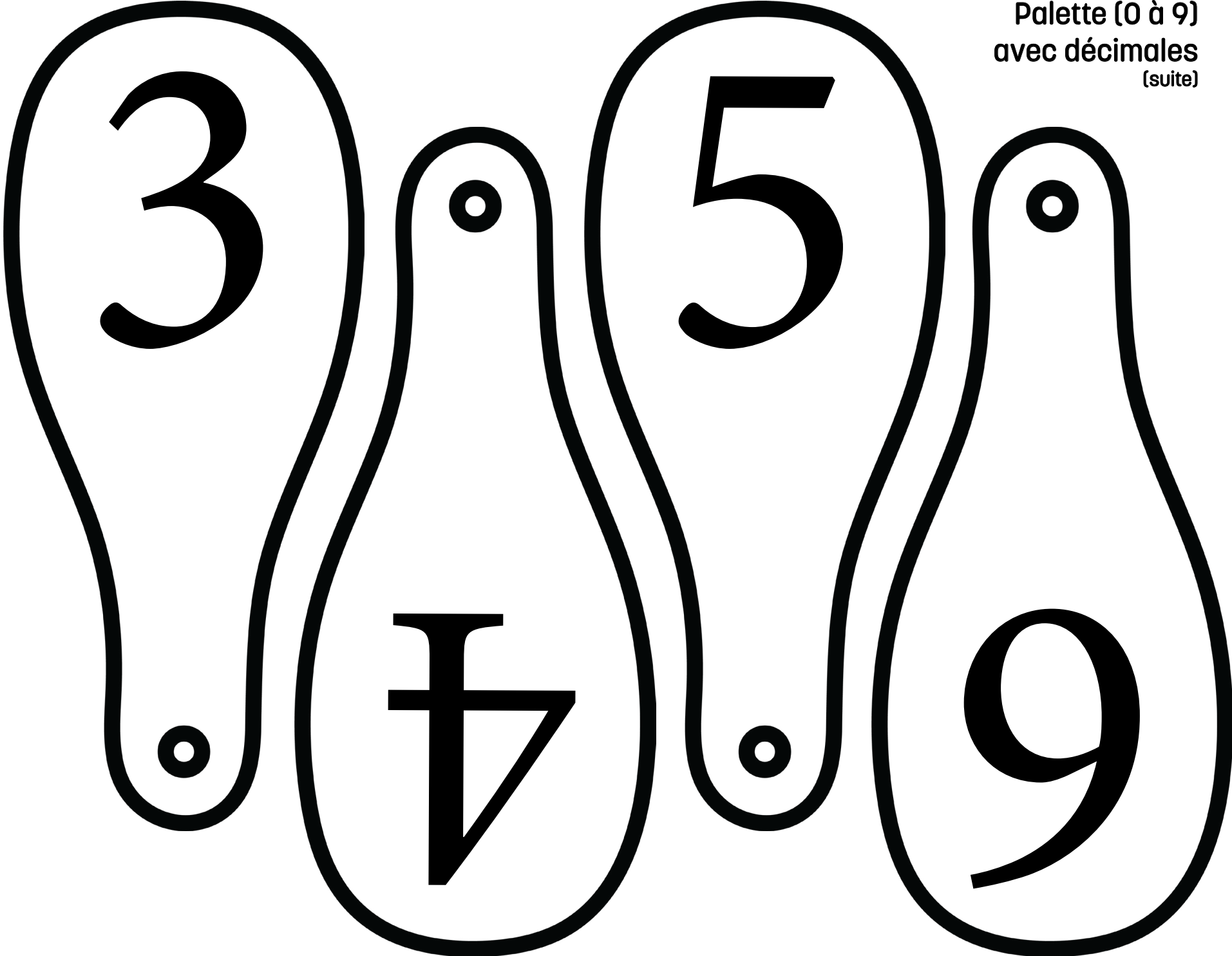

Palette (0 à 9)  
avec décimales  
(suite)

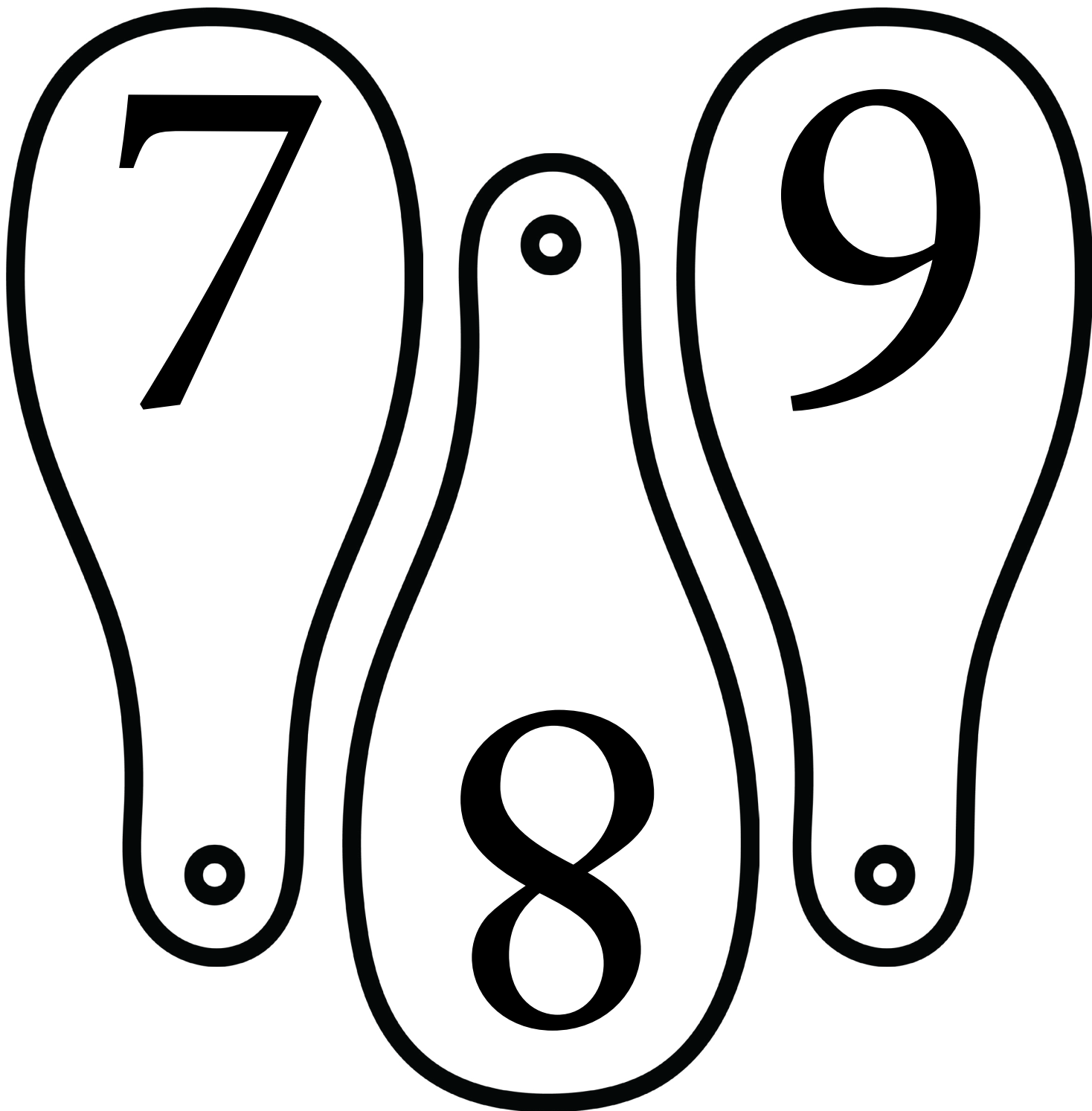

# Palette (0 à 10) de cartes à 10 points

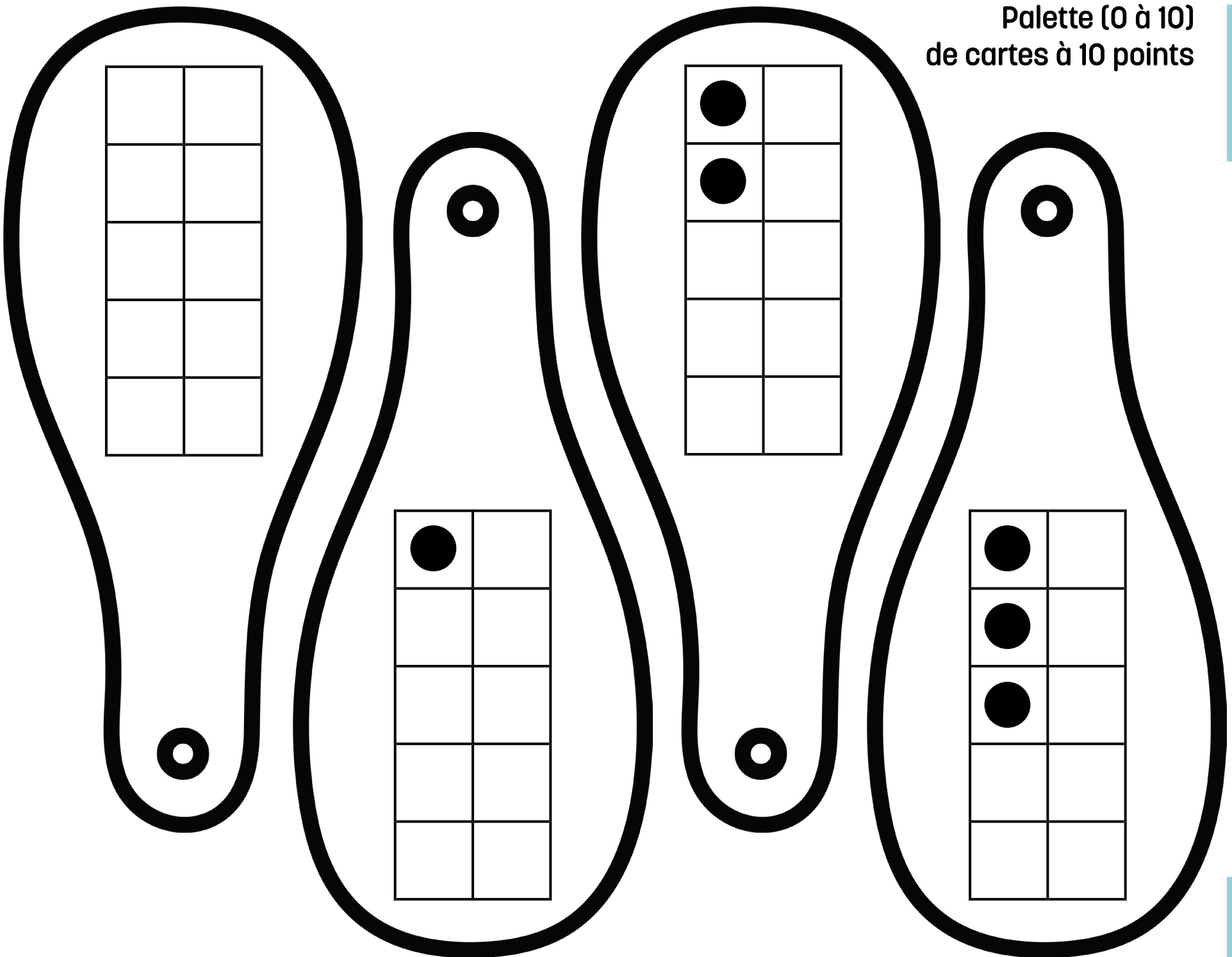

# Palette (0 à 10) de cartes à 10 points (suite)

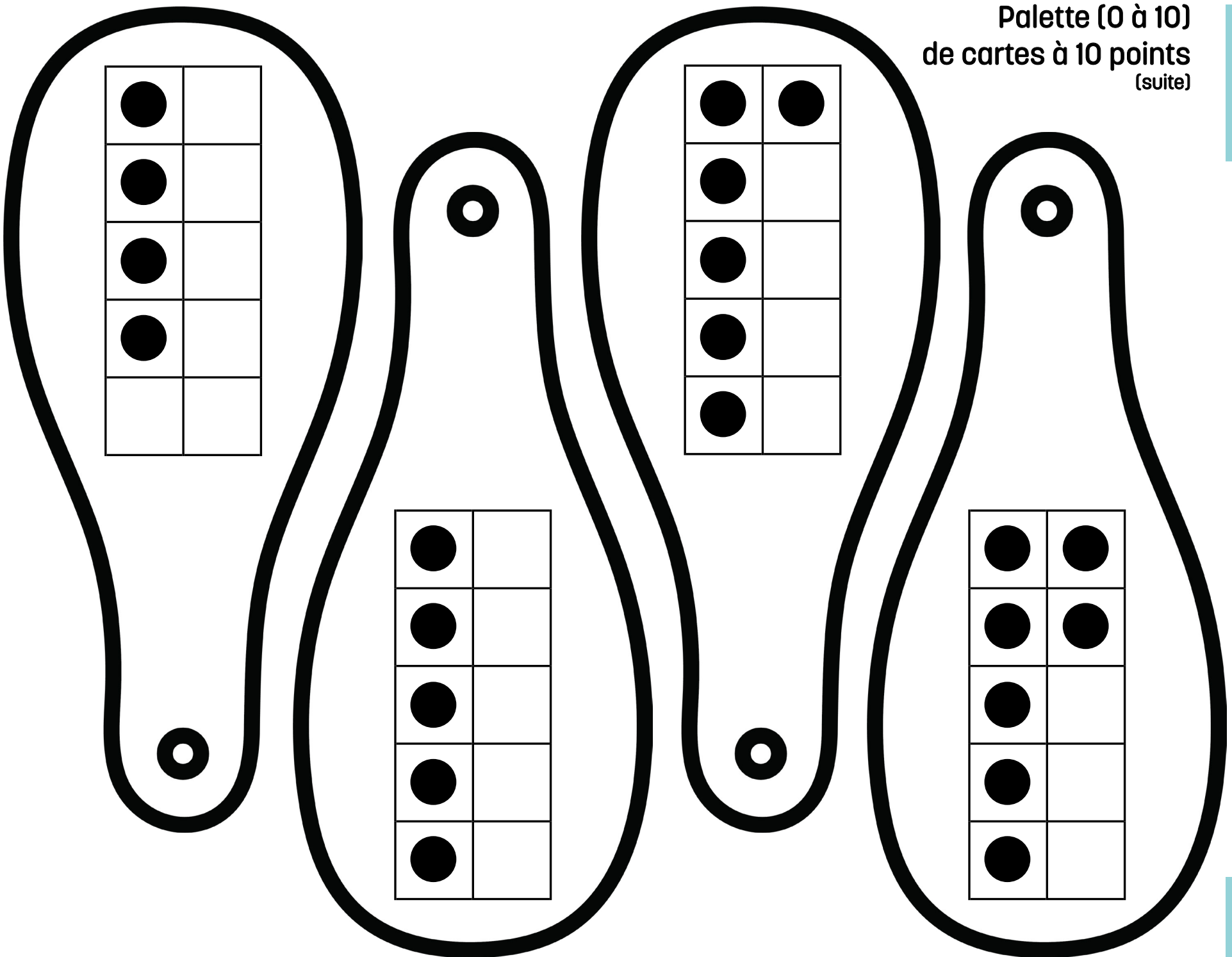

●	
●	
●	
●	

●	●
●	
●	
●	
●	
●	

●	
●	
●	
●	
●	
●	

●	●
●	●
●	
●	
●	
●	





Palette (0 à 10)  
de cartes à 10 points  
(suite)

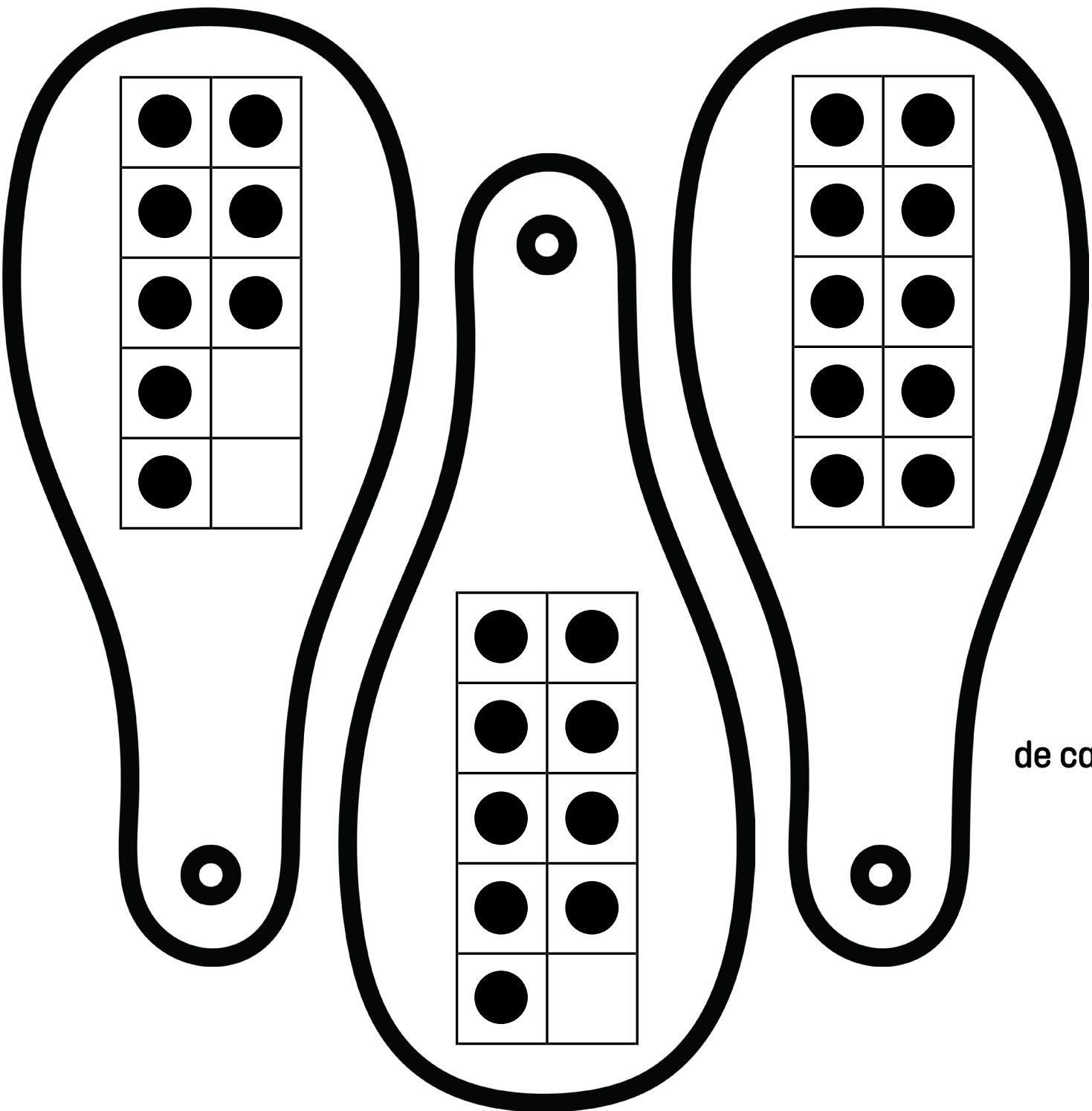

## Bande numérique de 1 à 10 représentations imagée et symboliques

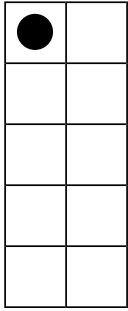
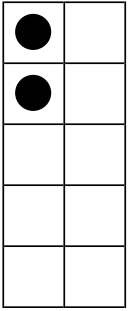
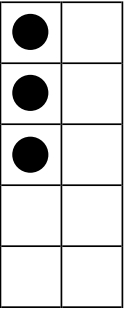
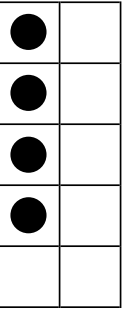
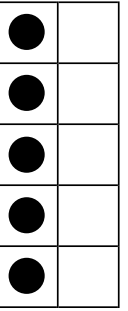
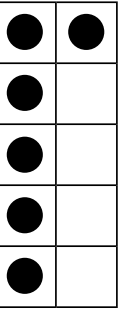
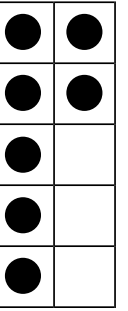
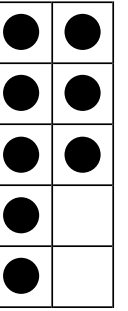
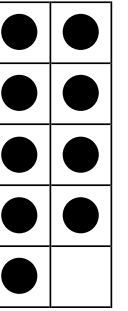
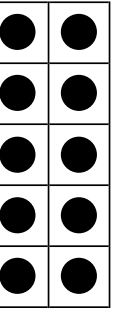
<b>1</b>	<b>2</b>	<b>3</b>	<b>4</b>	<b>5</b>	<b>6</b>	<b>7</b>	<b>8</b>	<b>9</b>	<b>10</b>
un	deux	trois	quatre	cinq	six	sept	huit	neuf	dix
									

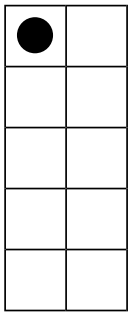
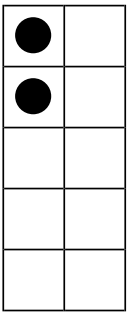
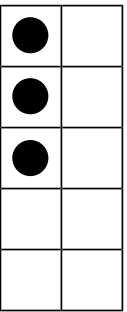
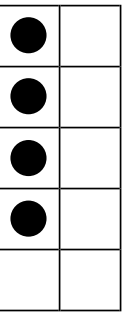
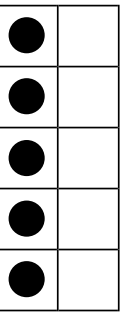
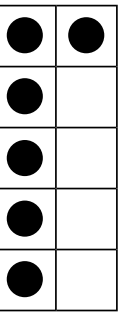
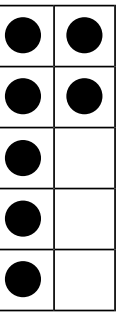
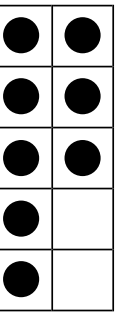
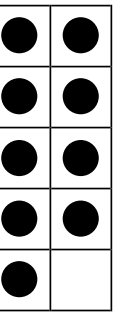
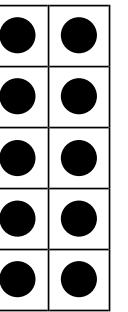

## Bande numérique de 1 à 10 représentation imagée et symboliques

<b>1</b>	<b>2</b>	<b>3</b>	<b>4</b>	<b>5</b>	<b>6</b>	<b>7</b>	<b>8</b>	<b>9</b>	<b>10</b>
un	deux	trois	quatre	cinq	six	sept	huit	neuf	dix
									

# Nombres en chiffres de 1 à 100

1	2	3	4	5	6	7	8	9	10
11	12	13	14	15	16	17	18	19	20
21	22	23	24	25	26	27	28	29	30
31	32	33	34	35	36	37	38	39	40
41	42	43	44	45	46	47	48	49	50
51	52	53	54	55	56	57	58	59	60
61	62	63	64	65	66	67	68	69	70
71	72	73	74	75	76	77	78	79	80
81	82	83	84	85	86	87	88	89	90
91	92	93	94	95	96	97	98	99	100

## Nombres en lettres de 1 à 100

1 un	11 onze	21 vingt et un	31 trente et un	41 quarante et un	51 cinquante et un	61 soixante et un	71 soixante et onze	81 quatre-vingt-un	91 quatre-vingt-onze
2 deux	12 douze	22 vingt-deux	32 trente-deux	42 quarante-deux	52 cinquante-deux	62 soixante-deux	72 soixante-douze	82 quatre-vingt-deux	92 quatre-vingt-douze
3 trois	13 treize	23 vingt-trois	33 trente-trois	43 quarante-trois	53 cinquante-trois	63 soixante-trois	73 soixante-treize	83 quatre-vingt-trois	93 quatre-vingt-treize
4 quatre	14 quatorze	24 vingt-quatre	34 trente-quatre	44 quarante-quatre	54 cinquante-quatre	64 soixante-quatre	74 soixante-quatorze	84 quatre-vingt-quatre	94 quatre-vingt-quatorze
5 cinq	15 quinze	25 vingt-cinq	35 trente-cinq	45 quarante-cinq	55 cinquante-cinq	65 soixante-cinq	75 soixante-quinze	85 quatre-vingt-cinq	95 quatre-vingt-quinze
6 six	16 seize	26 vingt-six	36 trente-six	46 quarante-six	56 cinquante-six	66 soixante-six	76 soixante-seize	86 quatre-vingt-six	96 quatre-vingt-seize
7 sept	17 dix-sept	27 vingt-sept	37 trente-sept	47 quarante-sept	57 cinquante-sept	67 soixante-sept	77 soixante-dix-sept	87 quatre-vingt-sept	97 quatre-vingt-dix-sept
8 huit	18 dix-huit	28 vingt-huit	38 trente-huit	48 quarante-huit	58 cinquante-huit	68 soixante-huit	78 soixante-dix-huit	88 quatre-vingt-huit	98 quatre-vingt-dix-huit
9 neuf	19 dix-neuf	29 vingt-neuf	39 trente-neuf	49 quarante-neuf	59 cinquante-neuf	69 soixante-neuf	79 soixante-dix-neuf	89 quatre-vingt-neuf	99 quatre-vingt-dix-neuf
10 dix	20 vingt	30 trente	40 quarante	50 cinquante	60 soixante	70 soixante-dix	80 quatre-vingts	90 quatre-vingt-dix	100 cent

# Bandes fractionnaires



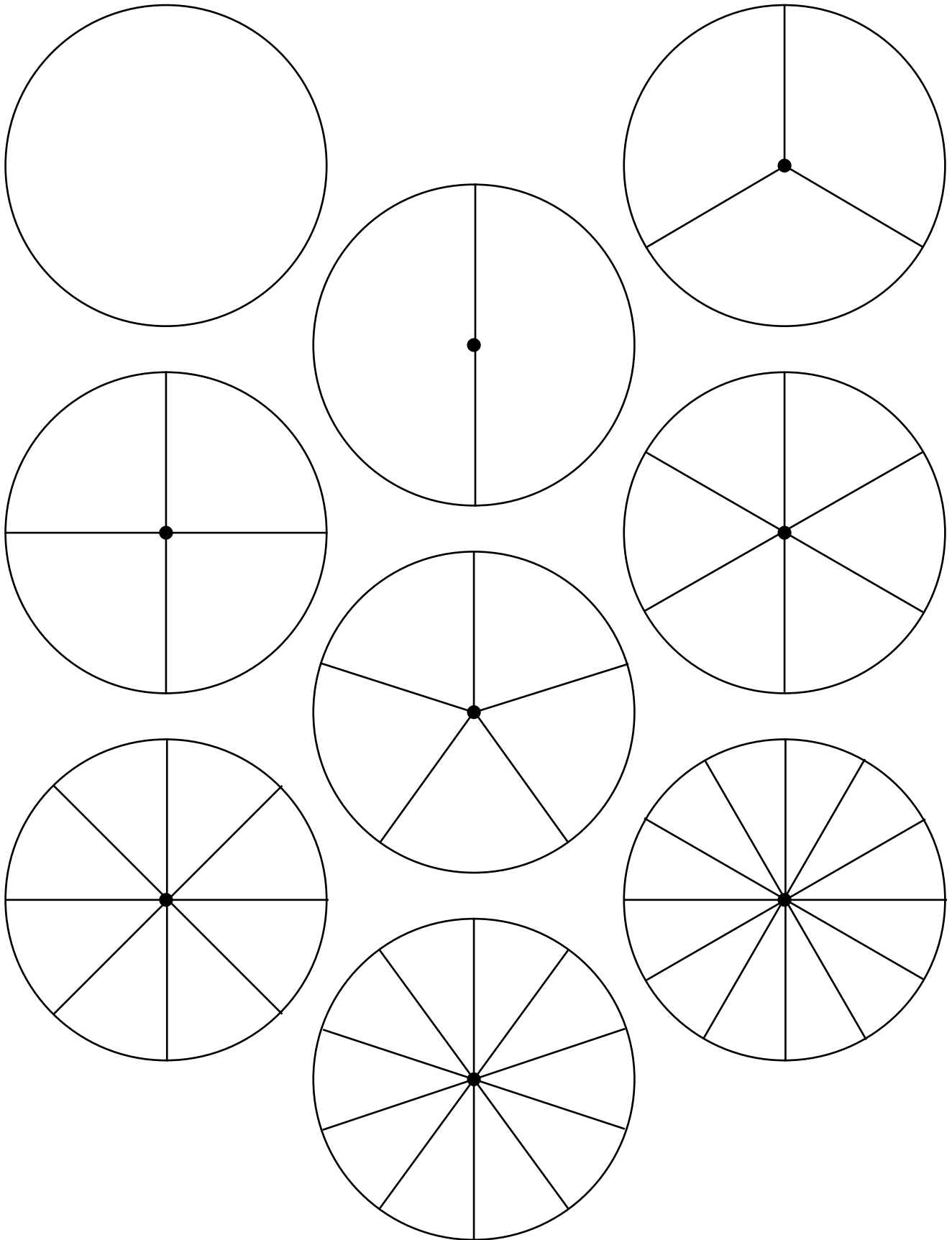

# Cercles fractionnaires

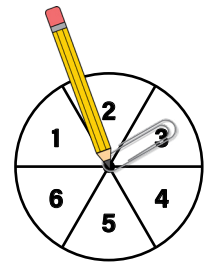
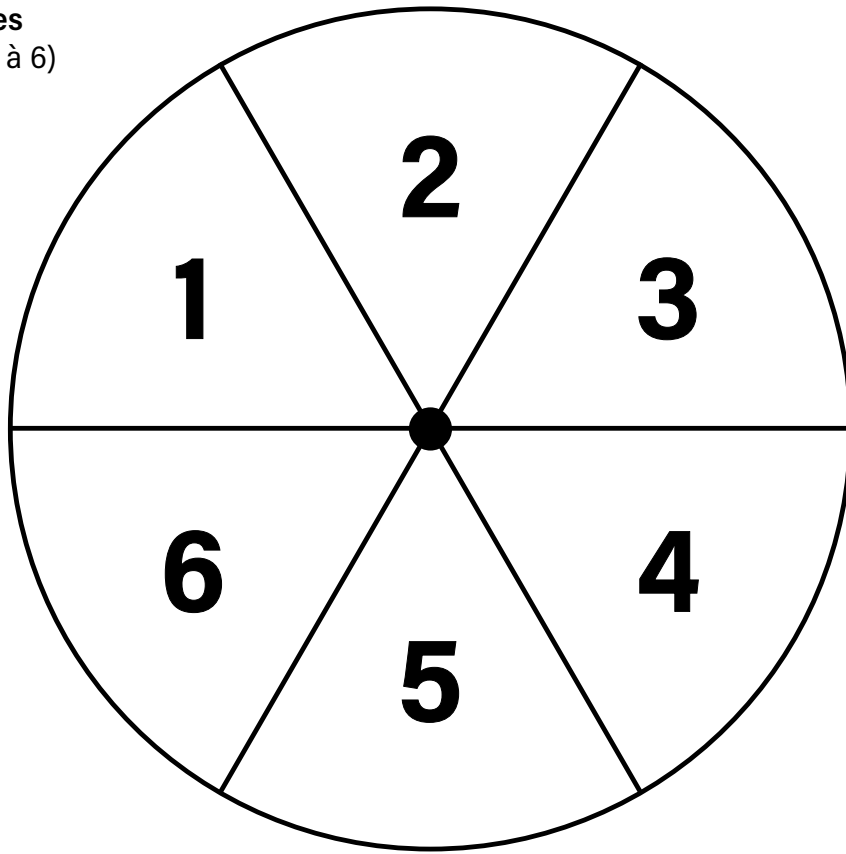

**Les roulettes - Chiffres**  
Divisée en sixièmes (1 à 6)

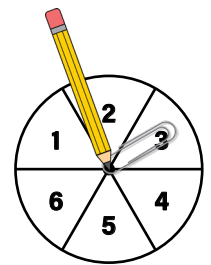
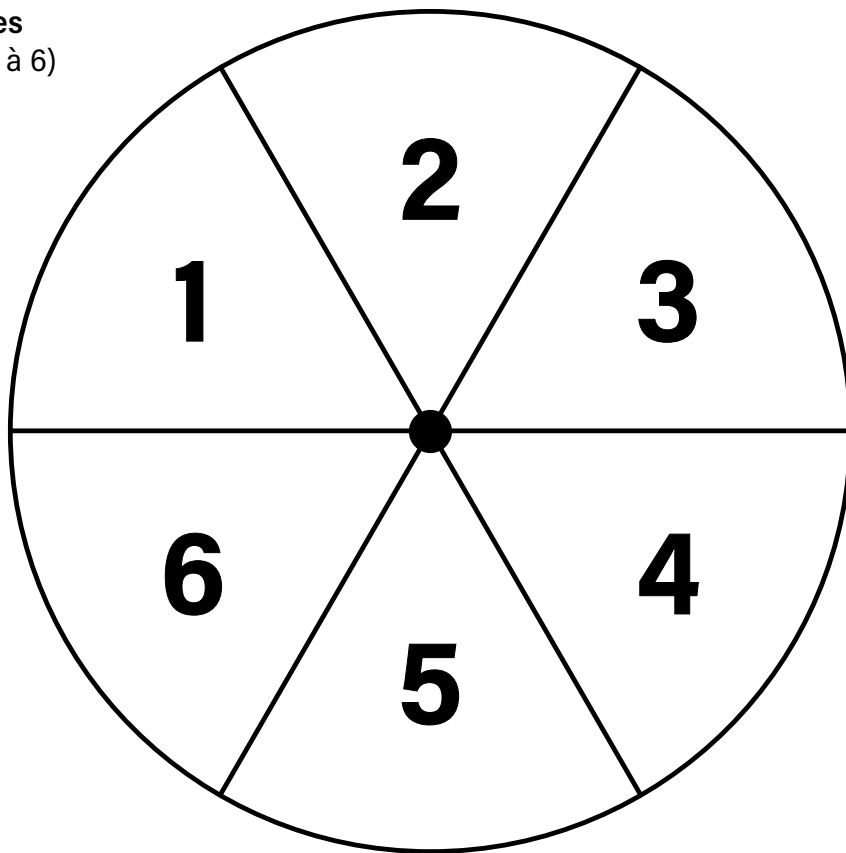

**Les roulettes - Chiffres**  
Divisée en sixièmes (1 à 6)



**Les roulettes - Chiffres**  
Divisée en huitièmes (1 à 8)

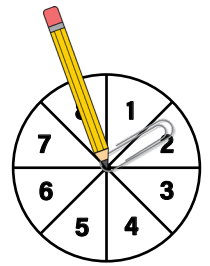
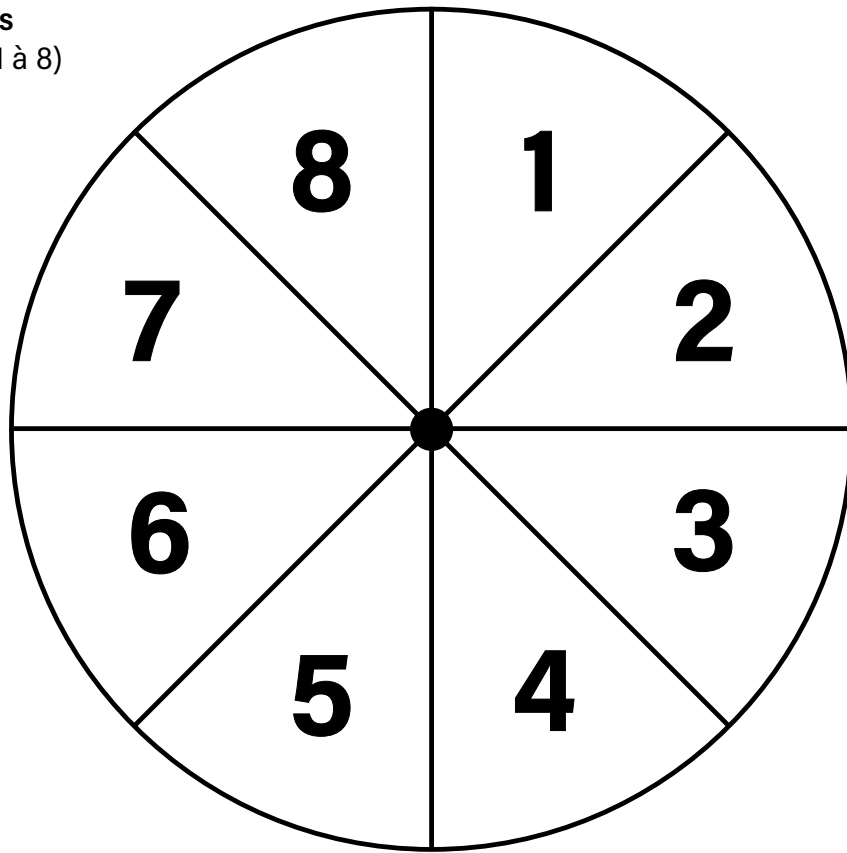

**Les roulettes - Chiffres**  
Divisée en huitièmes (1 à 8)

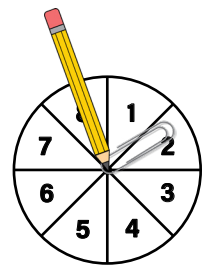
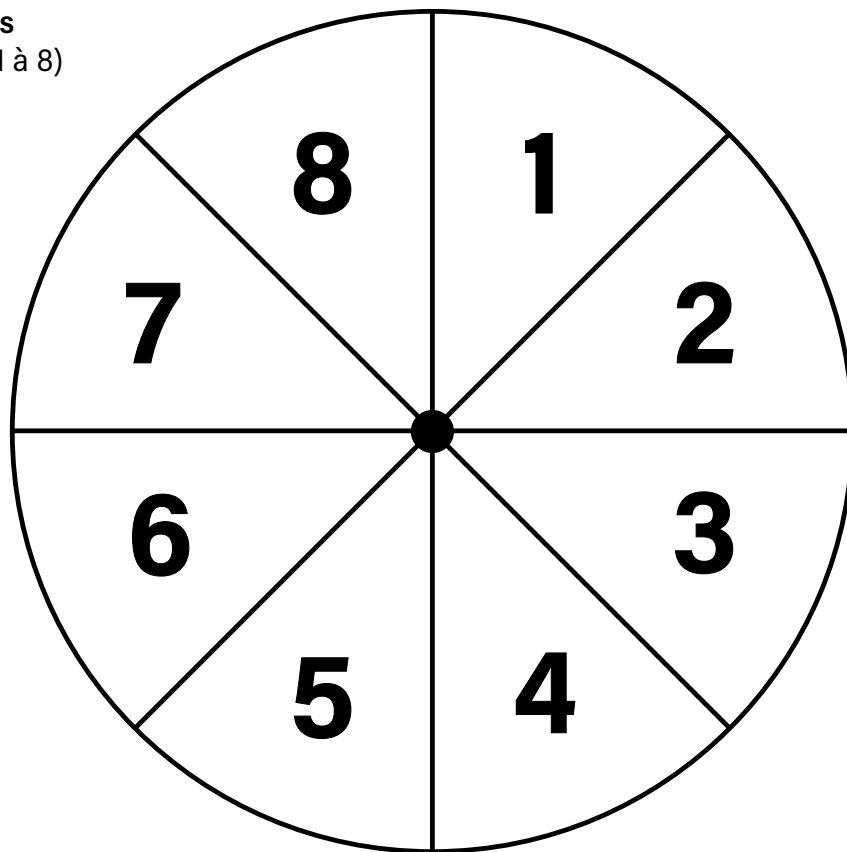

**Les roulettes - Chiffres**  
Divisée en dix (0 à 9)

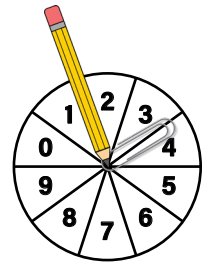
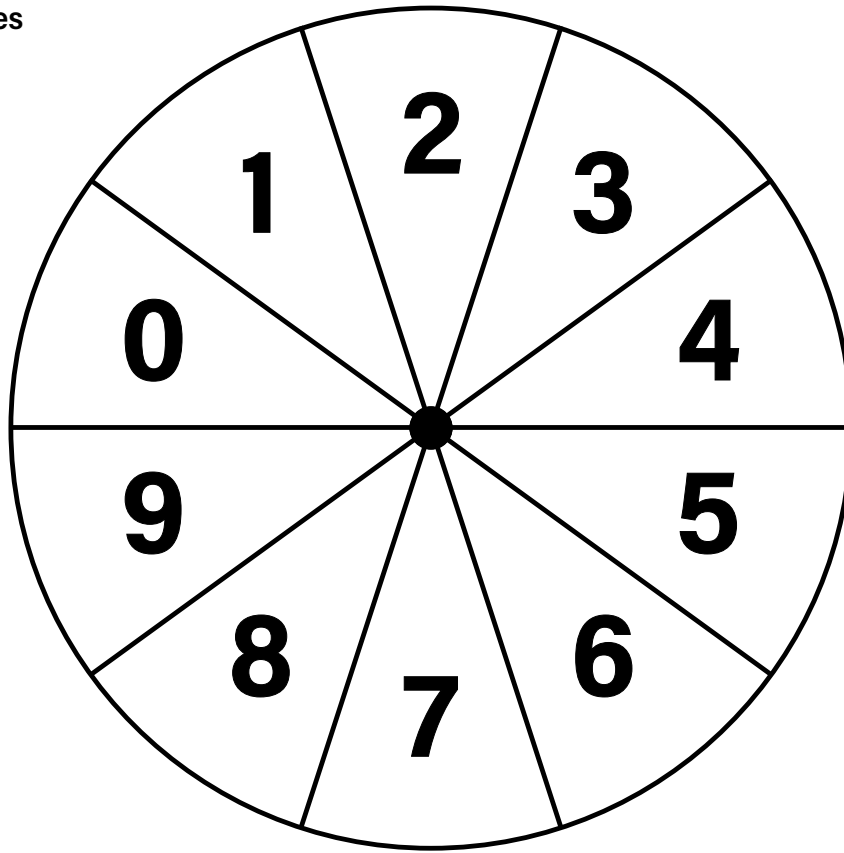

**Les roulettes - Chiffres**  
Divisée en dix (0 à 9)

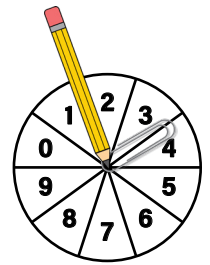
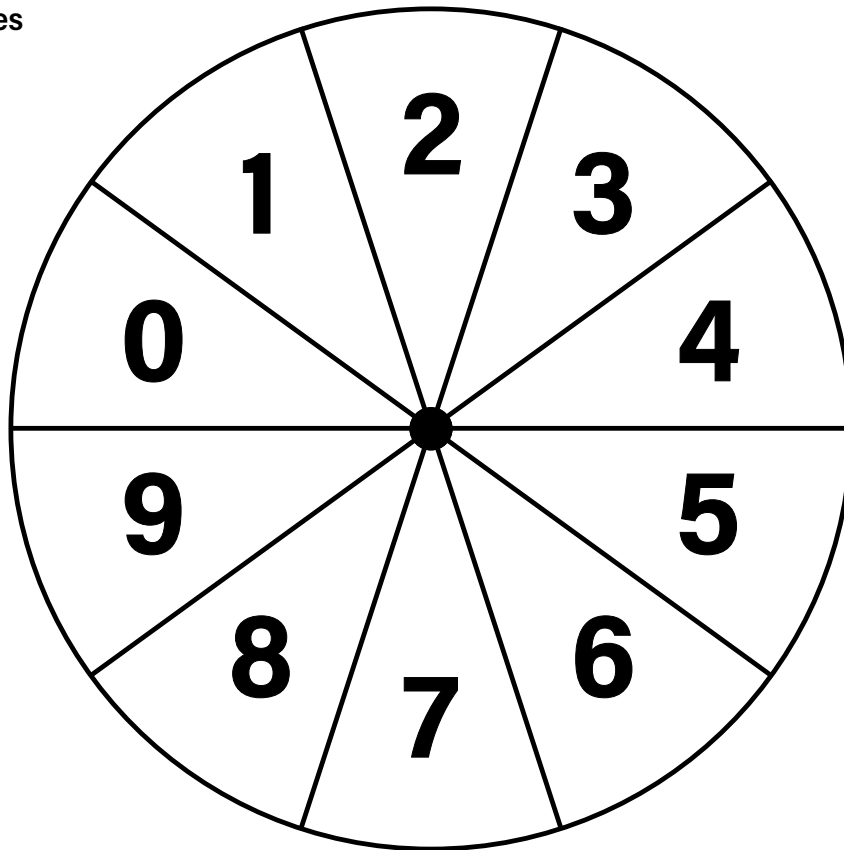



**Les roulettes - Chiffres**  
Divisée en dixièmes (1 à 10)

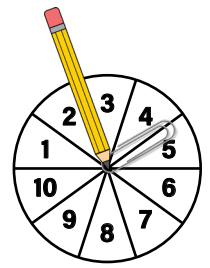
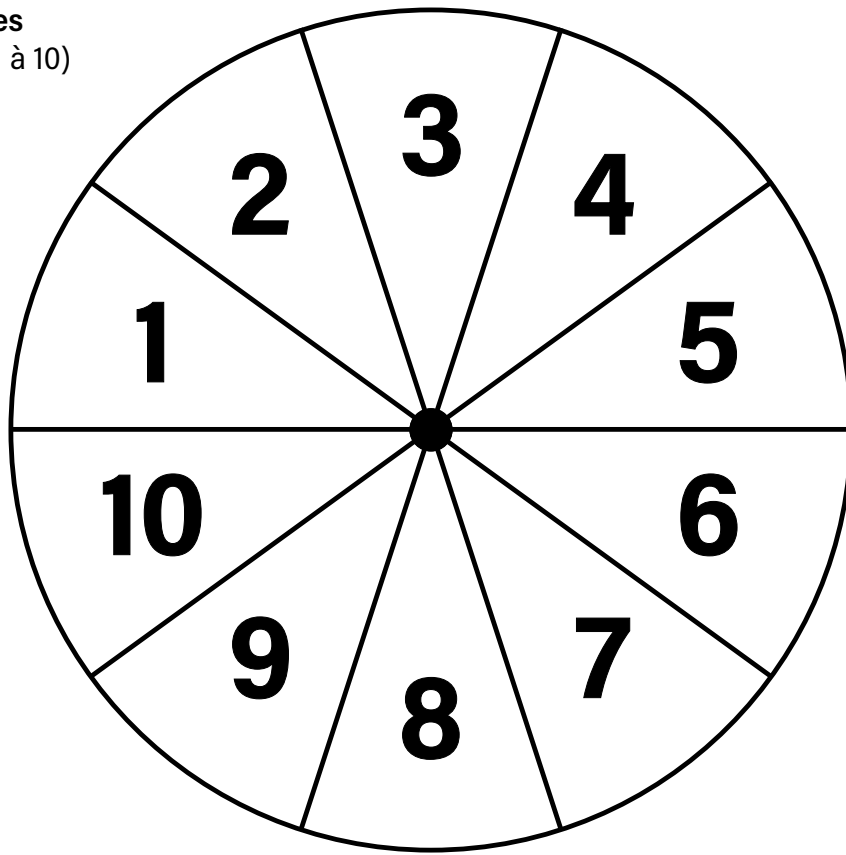

**Les roulettes - Chiffres**  
Divisée en dixièmes (1 à 10)

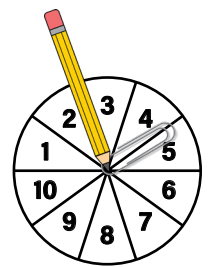
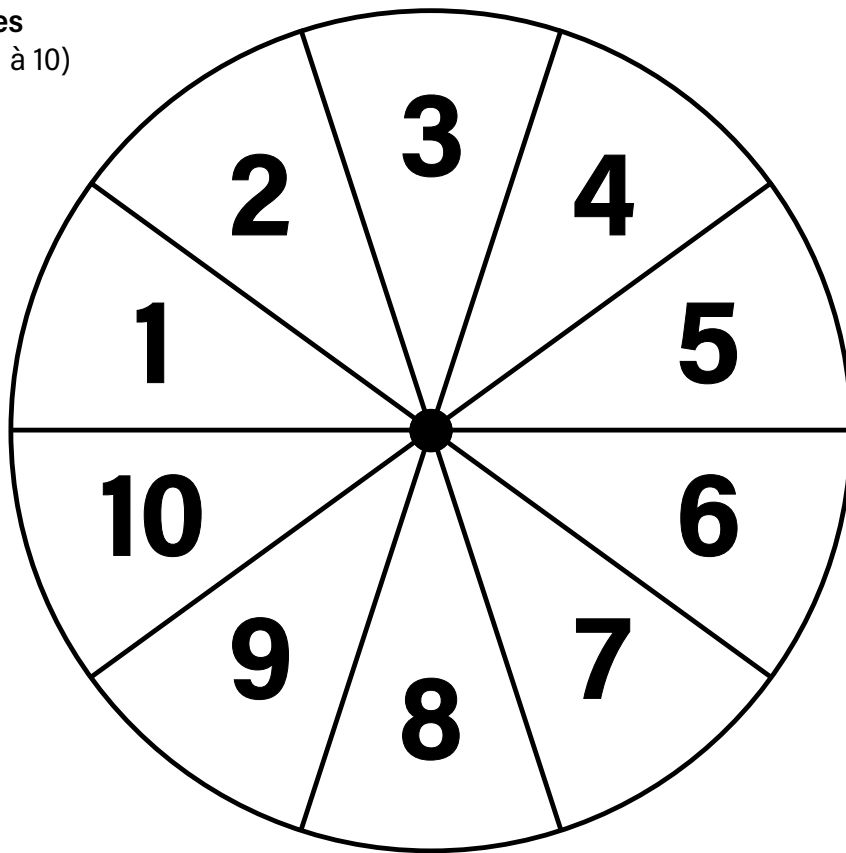

**Les roulettes**  
Cartes à points

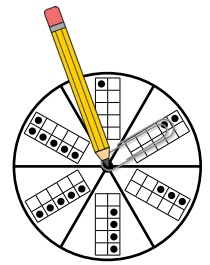
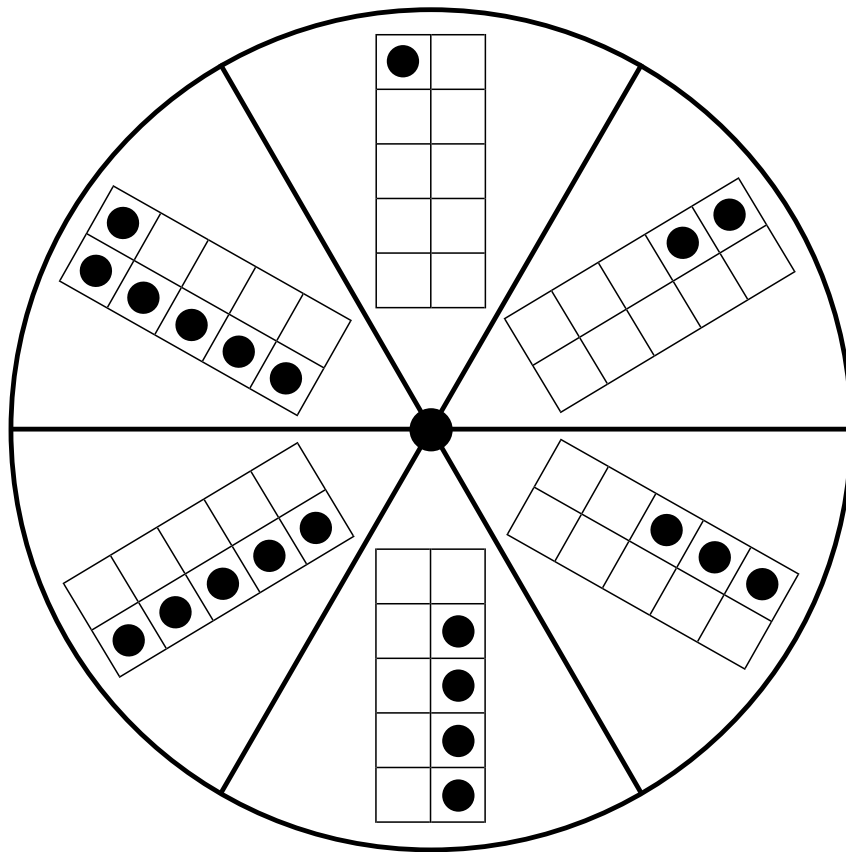

**Les roulettes**  
Cartes à points

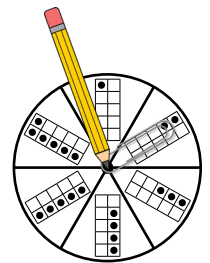
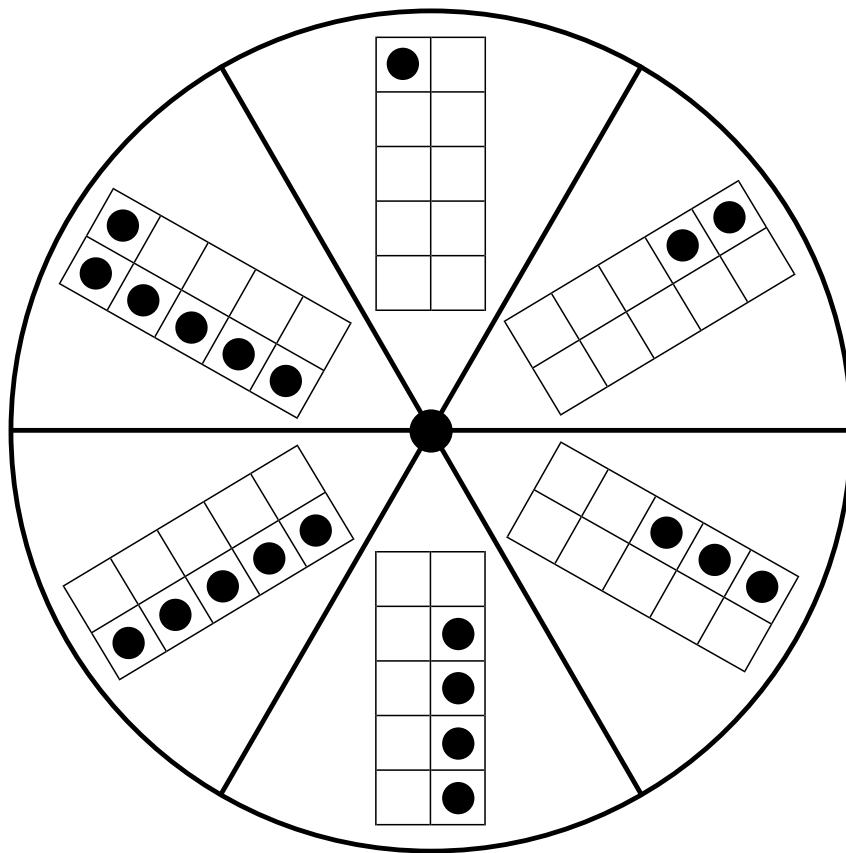

**Les roulettes**

Symboles d'opérations

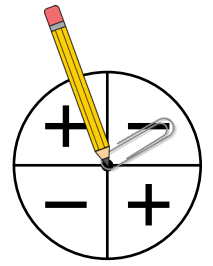
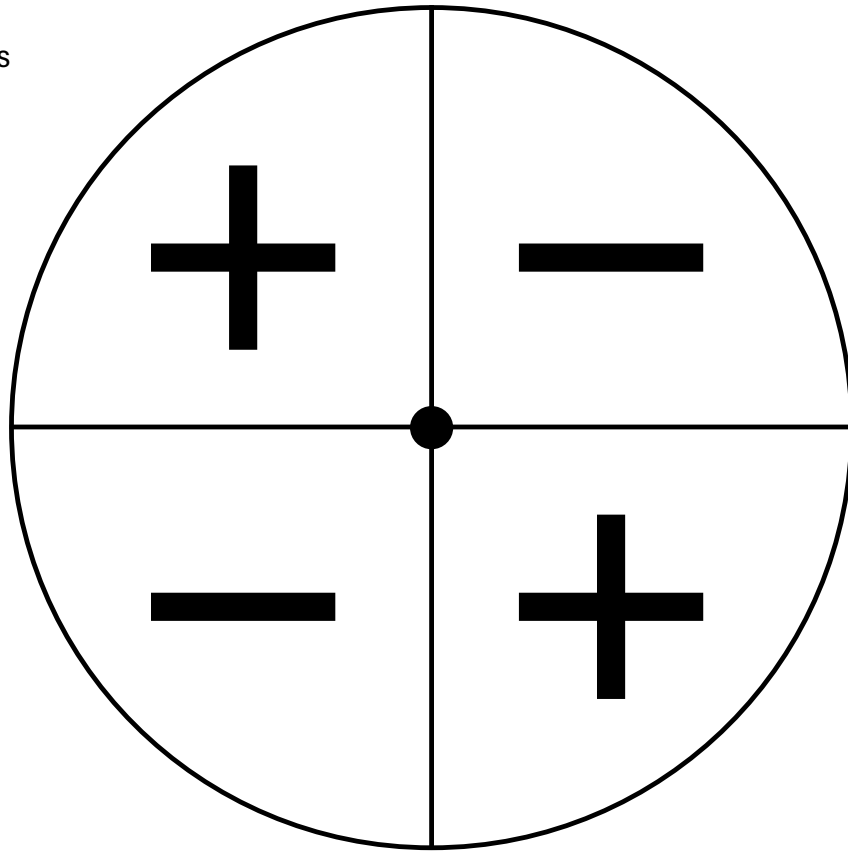

**Les roulettes**

Symboles d'opérations

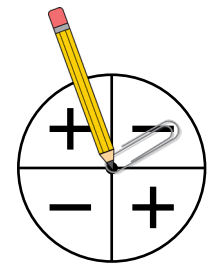
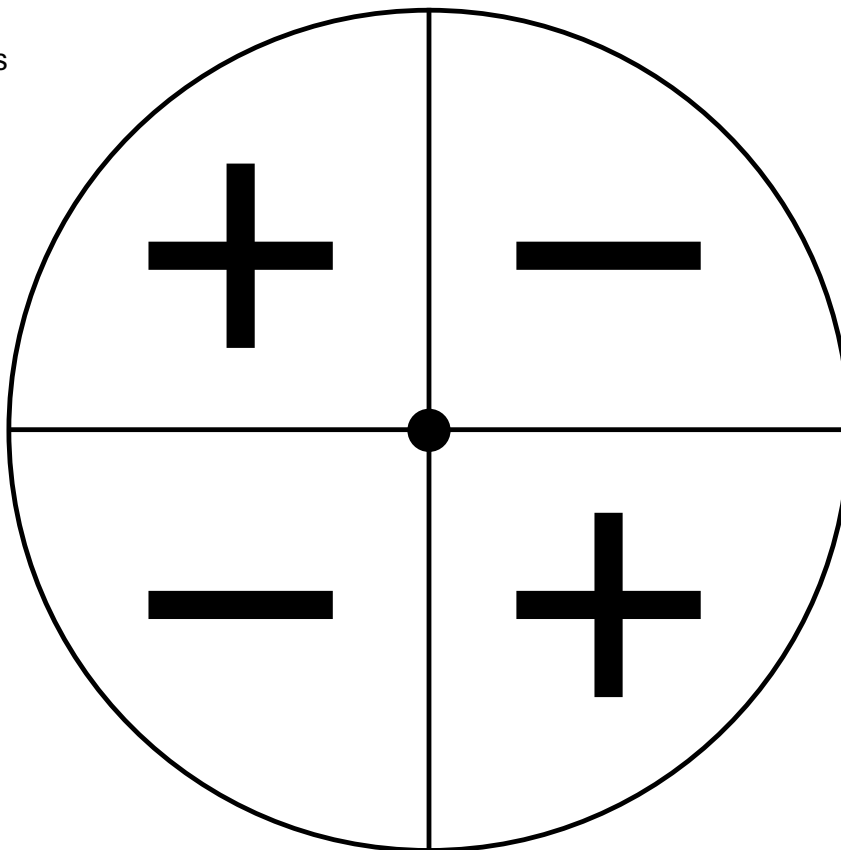

Les roulettes

Symboles d'opérations

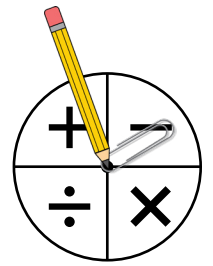
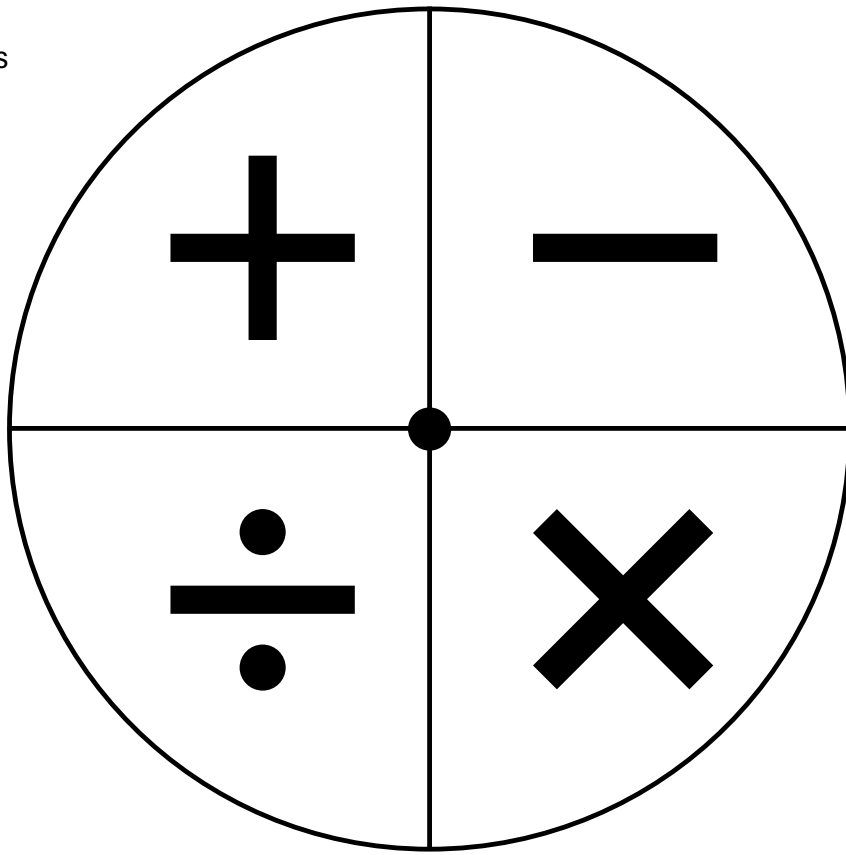

Les roulettes

Symboles d'opérations

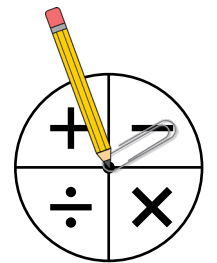
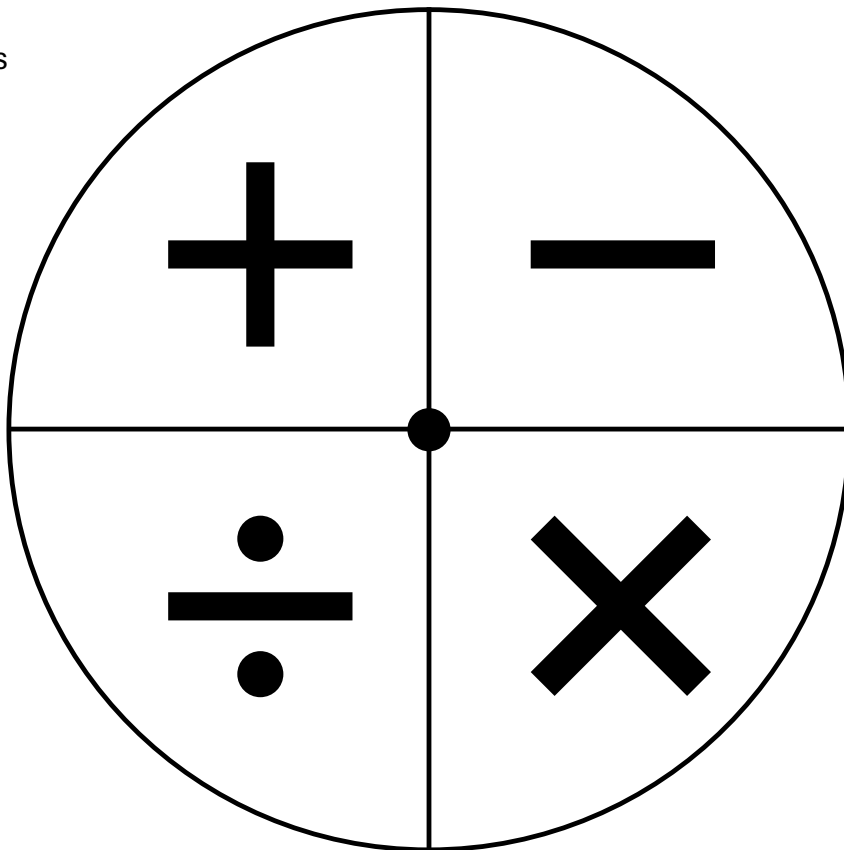

**Les roulettes**

Divisée en quarts (un de plus,  
un de moins, deux de plus,  
deux de moins)

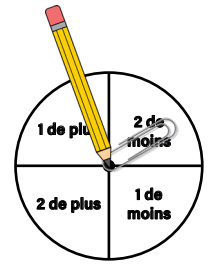
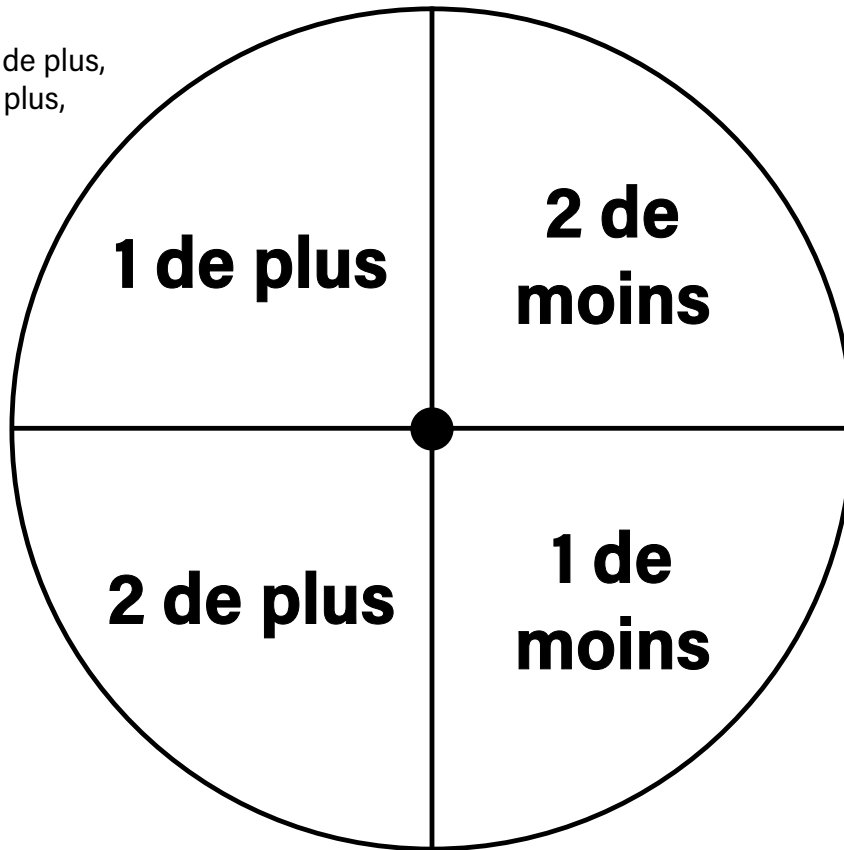
**Les roulettes**

Divisée en quarts (un de plus,  
un de moins, deux de plus,  
deux de moins)

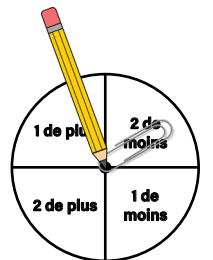
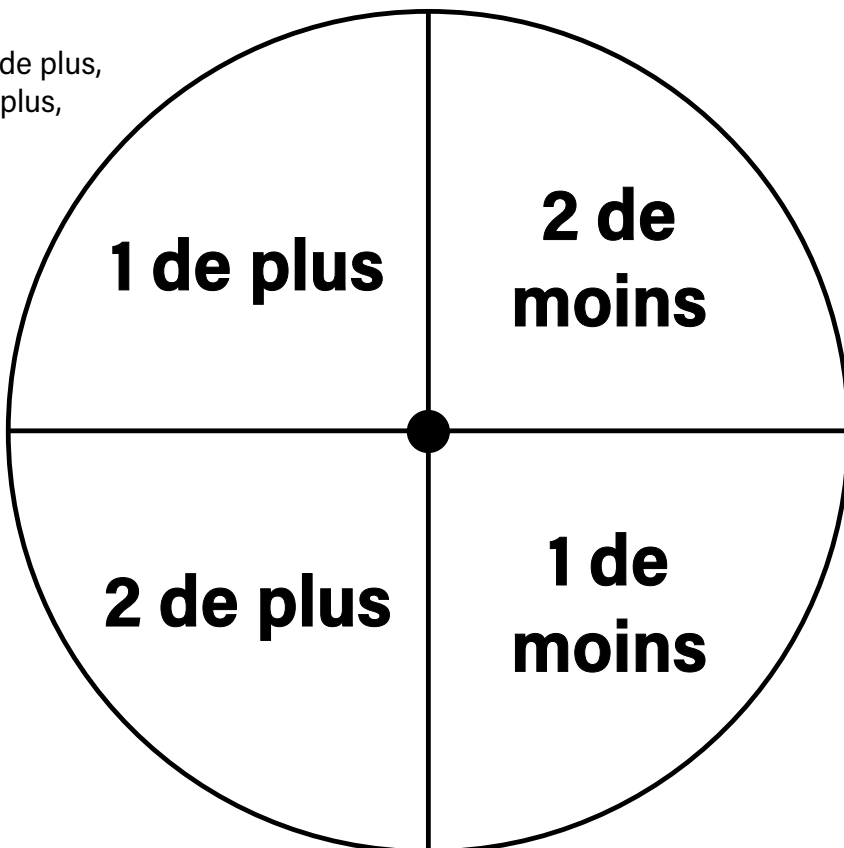

**Les roulettes**

Divisée en quarts (vides)

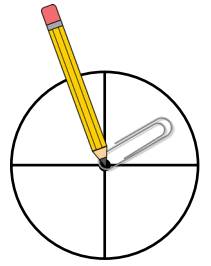
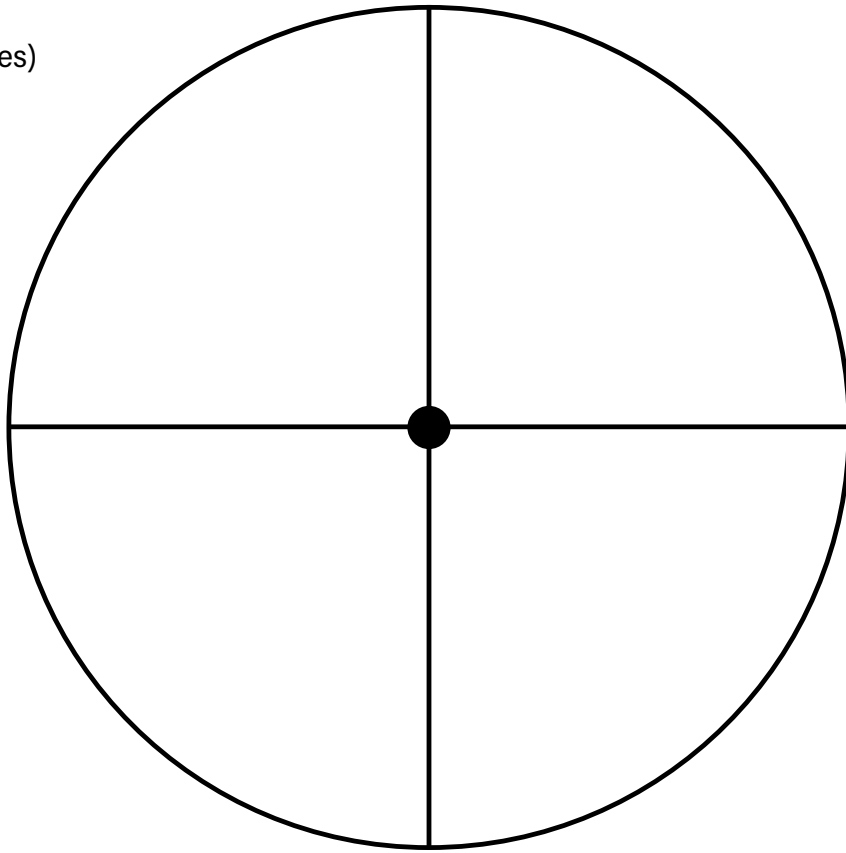

**Les roulettes**

Divisée en quarts (vides)

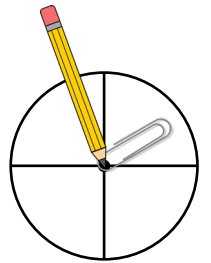
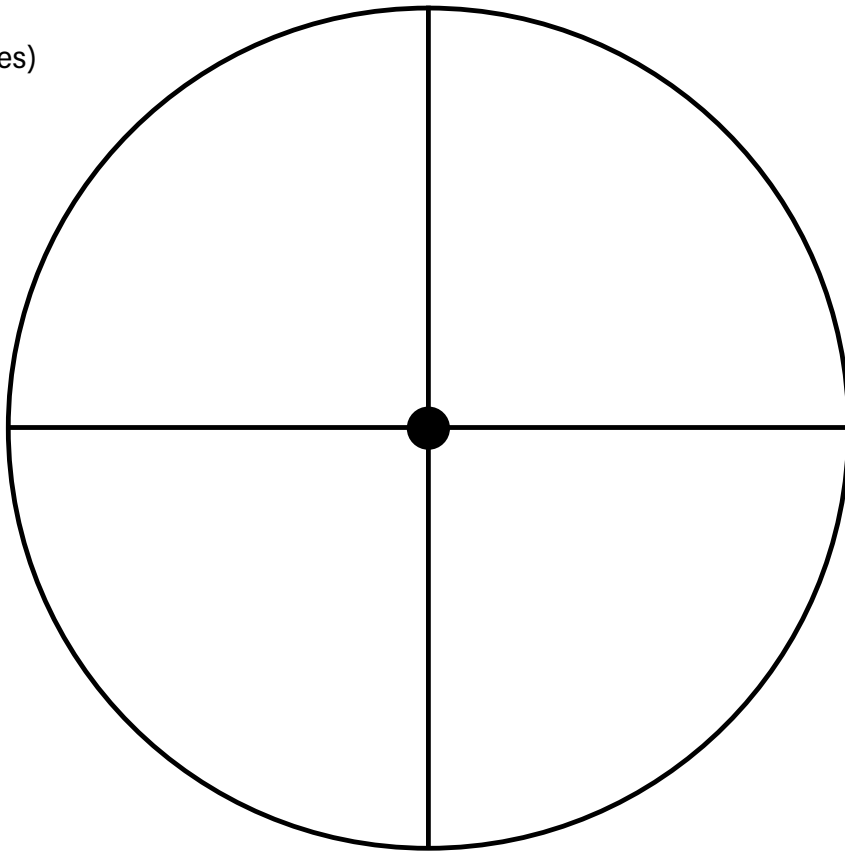

**Les roulettes**

Divisée en sixièmes (vides)

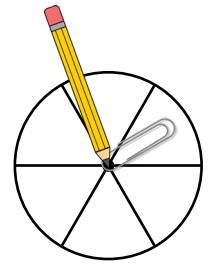
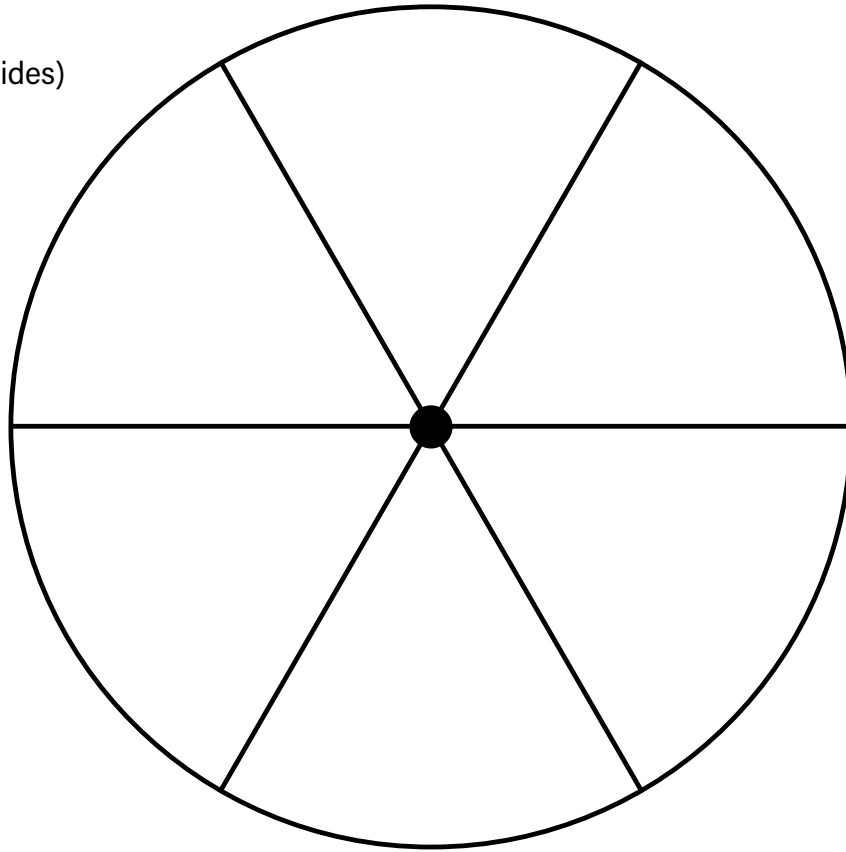

**Les roulettes**

Divisée en sixièmes (vides)

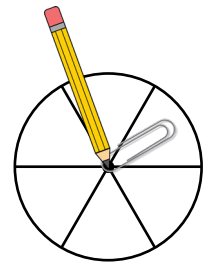
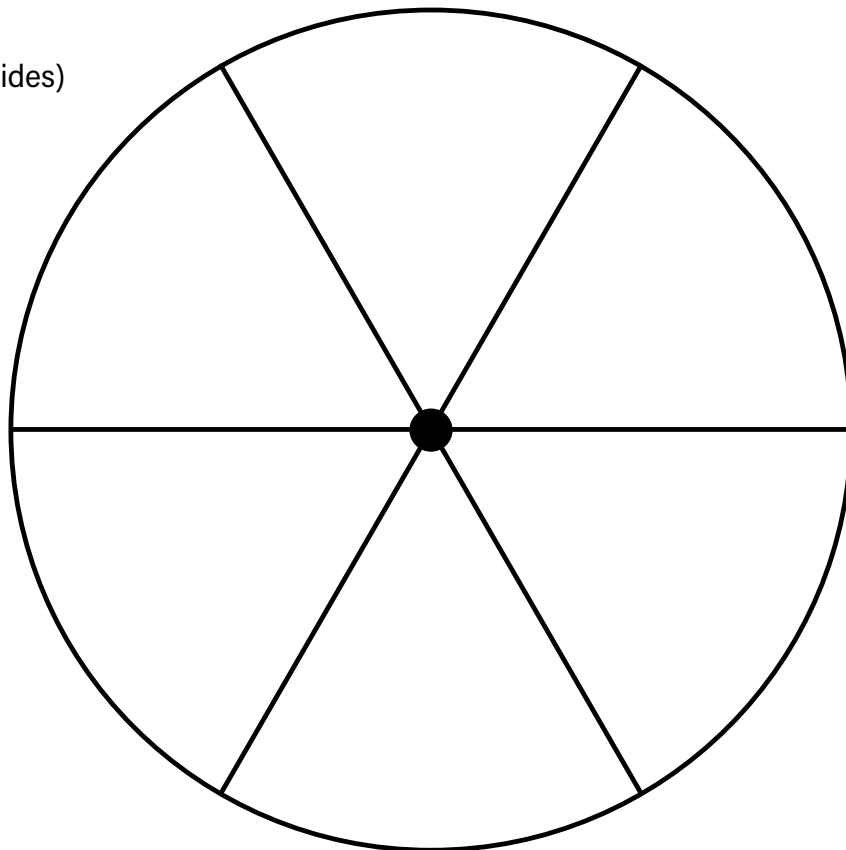

**Les roulettes**

Divisée en huitièmes (vides)

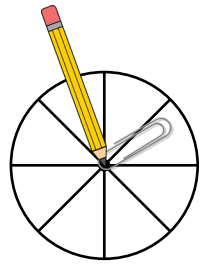
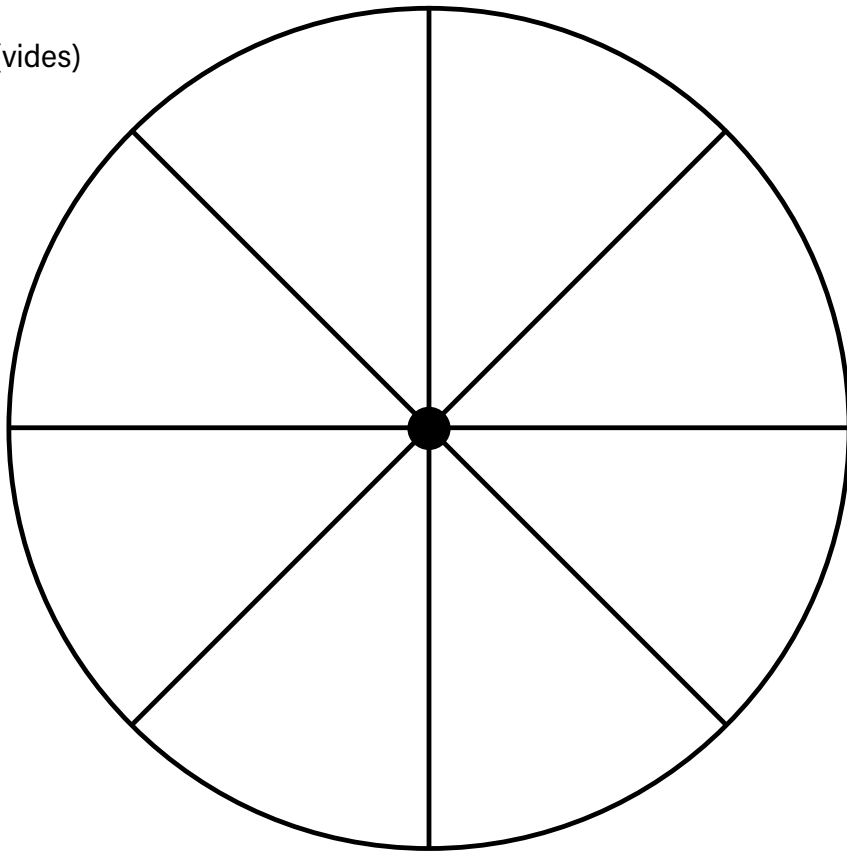

**Les roulettes**

Divisée en huitièmes (vides)

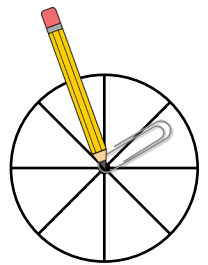
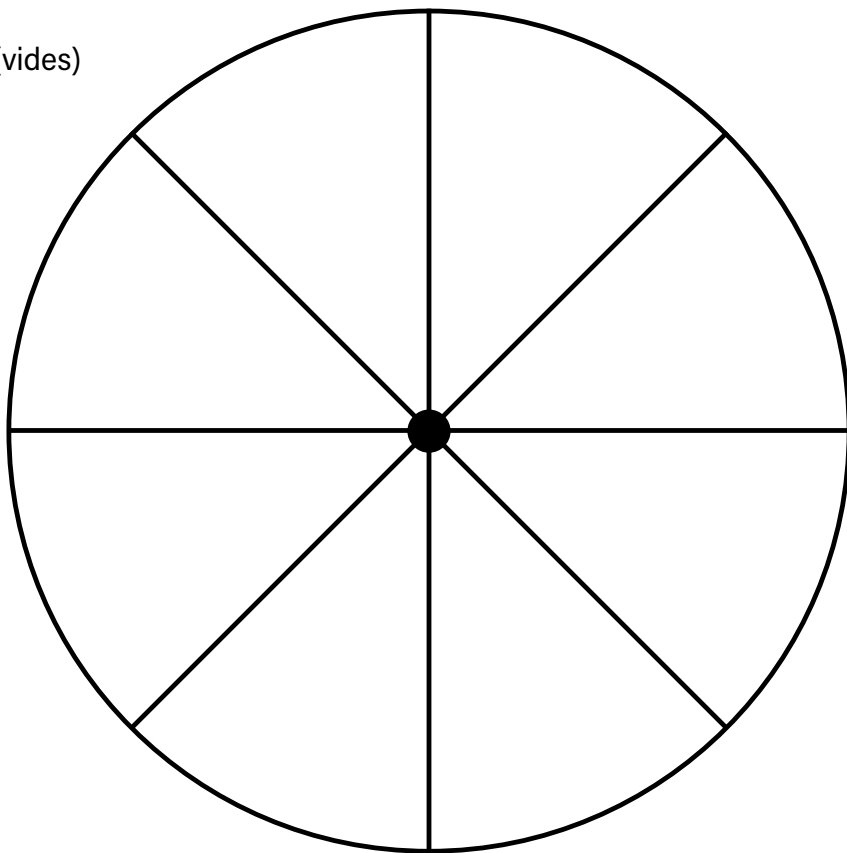



**Les roulettes**

Divisée en dixièmes (vides)

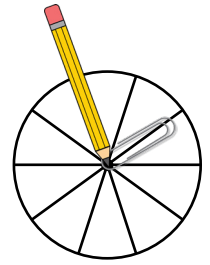
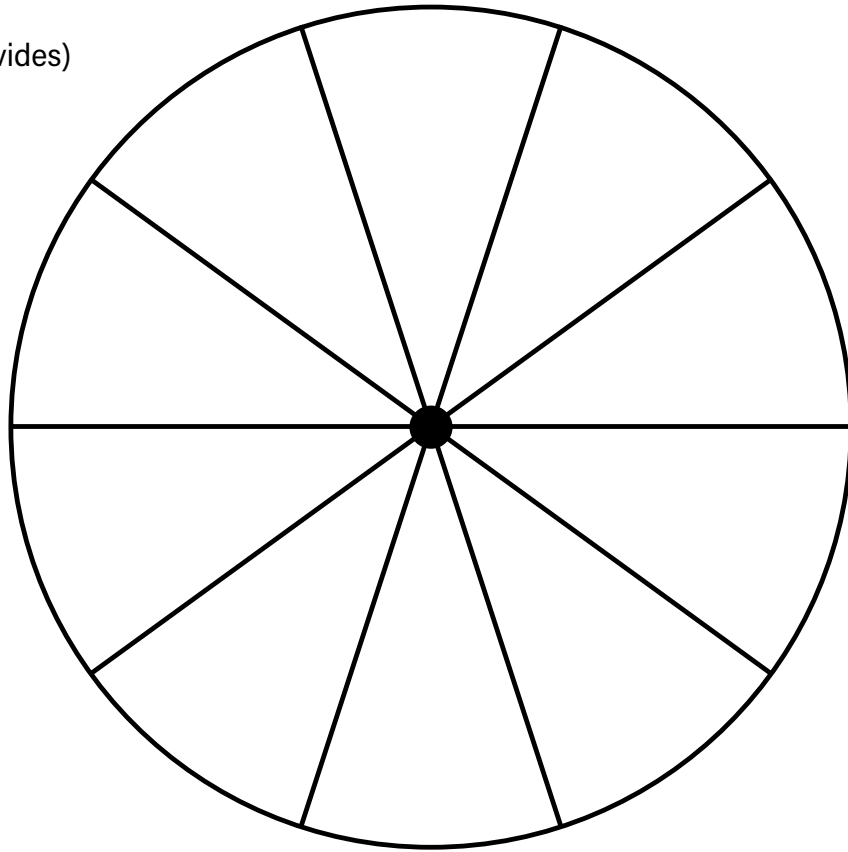

**Les roulettes**

Divisée en dixièmes (vides)

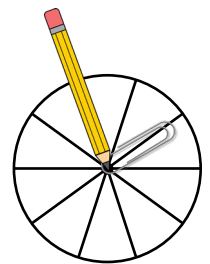
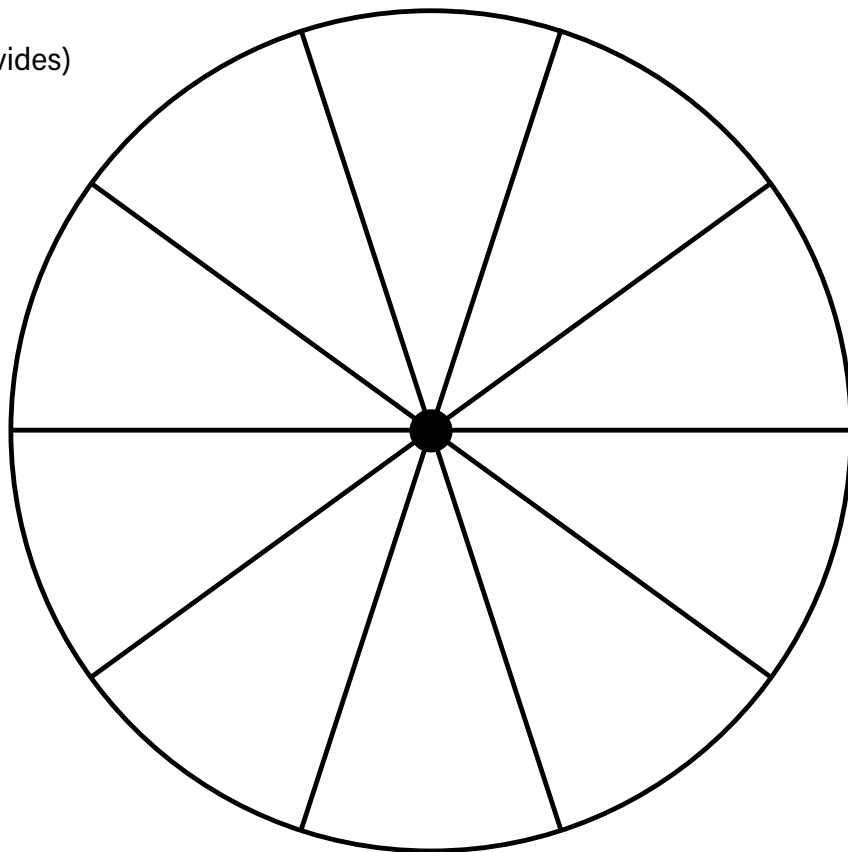



**+1  
1 de plus que**

**MON NOMBRE EST**  
\_\_\_\_\_



**Constellation**

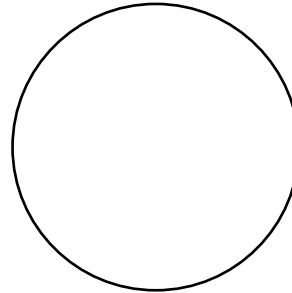

**Carte à 5 points**

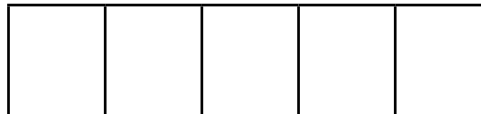

**-1  
1 de moins que**



**Cordes à 10 billes**

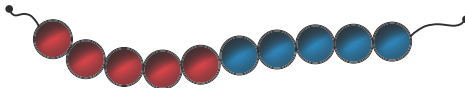

**Place ou dessine  
la quantité d'objets  
qui correspond à  
ton nombre.**

**+2**  
**2 de plus que**

**-2**  
**2 de moins que**



**MON NOMBRE EST**

---

**La droite numérique**

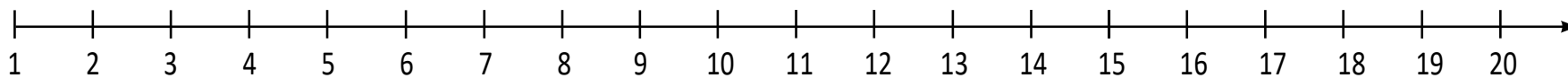

**Écris-le en mot**      **a, b, c...**

.....



**Comptes à rebours à partir de** \_\_\_\_\_

.....  
.....  
.....  
.....  
.....

**Avec une corde à billes :**





**Avec une corde à billes :**

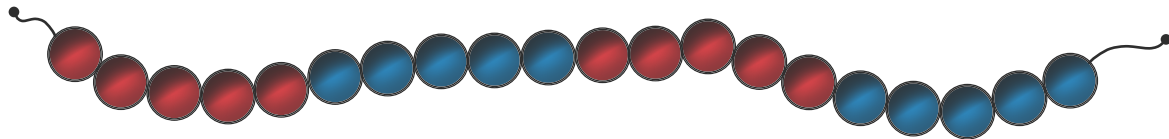

**Avec des marques de fréquences (III)**

**Avec des cubes emboîtables :**

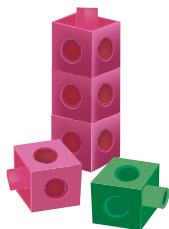

**Avec la représentation de mon choix**

**Pour faire 20...**

$$\boxed{\phantom{00}} + \underline{\phantom{00}} = 20$$

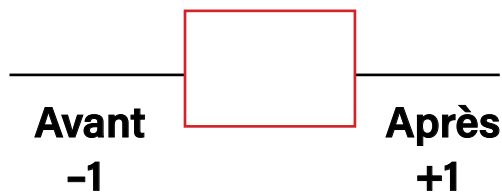

**Avec quatre additions :**

**Avec deux soustractions :**

**Représentation de mon nombre à l'aide de blocs de base 10**

Avant

Après

-19

+19

**Avec des marques de fréquences (H#)**



**MON NOMBRE EST**

\_\_\_\_\_



**C'est un nombre pair ou impair**

\_\_\_\_\_

**Encerle ton nombre**

1	2	3	4	5	6	7	8	9	10
11	12	13	14	15	16	17	18	19	20
21	22	23	24	25	26	27	28	29	30
31	32	33	34	35	36	37	38	39	40
41	42	43	44	45	46	47	48	49	50
51	52	53	54	55	56	57	58	59	60
61	62	63	64	65	66	67	68	69	70
71	72	73	74	75	76	77	78	79	80
81	82	83	84	85	86	87	88	89	90
91	92	93	94	95	96	97	98	99	100

**Avec une corde à billes :**

**La droite numérique**



### La droite numérique

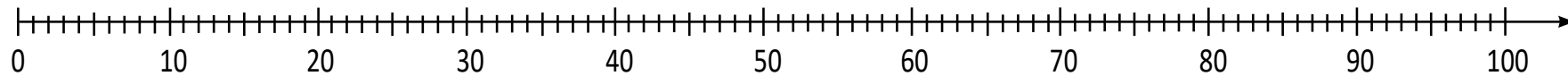

### Avec des blocs de base 10 :

\_\_\_\_\_ dizaines et \_\_\_\_\_ unités

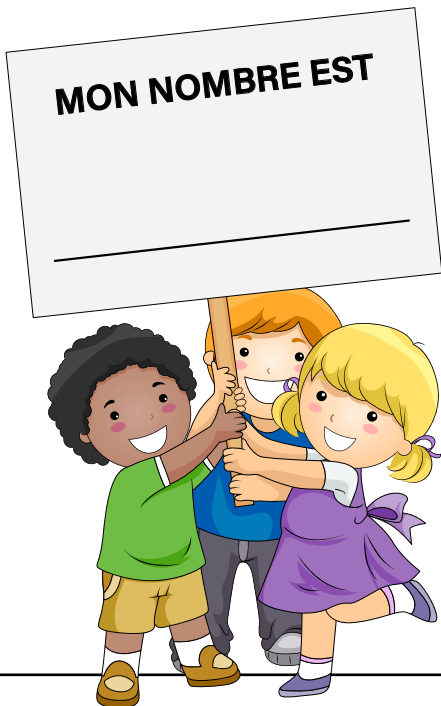

### Pour faire 100...

+ \_\_\_\_\_ = 100

### Pour faire 100...

+ \_\_\_\_\_ = 100

### Avec des cartes à points :

<input type="text"/>	<input type="text"/>	<input type="text"/>	<input type="text"/>	<input type="text"/>	<input type="text"/>	<input type="text"/>	<input type="text"/>	<input type="text"/>	<input type="text"/>	<input type="text"/>	<input type="text"/>	<input type="text"/>	<input type="text"/>	<input type="text"/>	<input type="text"/>	<input type="text"/>	<input type="text"/>	<input type="text"/>	<input type="text"/>	<input type="text"/>	<input type="text"/>	<input type="text"/>	<input type="text"/>	<input type="text"/>
<input type="text"/>	<input type="text"/>	<input type="text"/>	<input type="text"/>	<input type="text"/>	<input type="text"/>	<input type="text"/>	<input type="text"/>	<input type="text"/>	<input type="text"/>	<input type="text"/>	<input type="text"/>	<input type="text"/>	<input type="text"/>	<input type="text"/>	<input type="text"/>	<input type="text"/>	<input type="text"/>	<input type="text"/>	<input type="text"/>	<input type="text"/>	<input type="text"/>	<input type="text"/>	<input type="text"/>	<input type="text"/>



**Sur un morceau de tableau de 100 :**

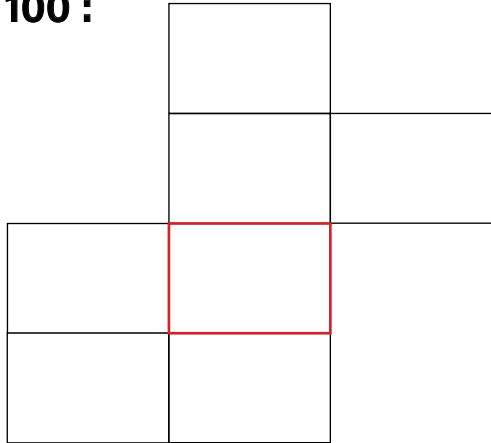

**Pour faire 100...**

+ \_\_\_\_\_ = 100

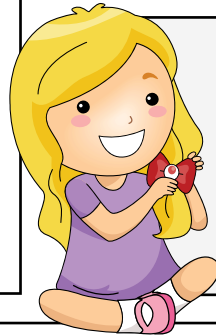

**MON NOMBRE EST**

\_\_\_\_\_

**Écris-le en mot a, b, c...**

-----

-----

-----

-----

-----

**Dans une addition avec la droite numérique :**

+ 37 = \_\_\_\_\_

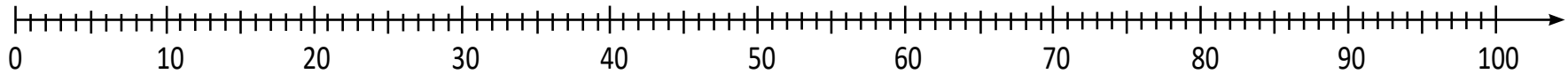

**Avec trois additions :**

**Avec deux soustractions :**

**Avec des blocs de base 10 :**



**J'ajoute 1 dizaine à mon nombre.**

**J'ajoute 6 unités à mon nombre.**

**J'ajoute 3 centaines à mon nombre.**

**C'est un nombre pair ou impair.**  
\_\_\_\_\_

**Je le représente à l'aide de blocs 10.**

\_\_\_\_\_

**-** \_\_\_\_\_ **+** \_\_\_\_\_

**Écris-le en mot a, b, c...**

\_\_\_\_\_

\_\_\_\_\_

\_\_\_\_\_

**MON NOMBRE EST**

\_\_\_\_\_

Centaine	Dizaine	Unité
<input type="text"/>	<input type="text"/>	<input type="text"/>

Il y a \_\_\_\_\_ centaine dans mon nombre,

Il y a \_\_\_\_\_ dizaines dans mon nombre.

Il y a \_\_\_\_\_ unités dans mon nombre.

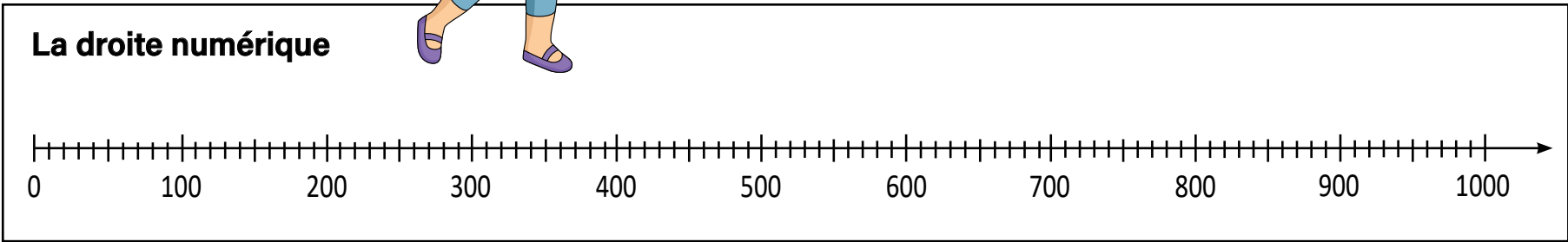

**Je fais des bons de \_\_\_\_\_ à partir de mon nombre**

<input type="text"/>	<input type="text"/>	<input type="text"/>	<input type="text"/>	<input type="text"/>	<input type="text"/>	<input type="text"/>	<input type="text"/>	<input type="text"/>
----------------------	----------------------	----------------------	----------------------	----------------------	----------------------	----------------------	----------------------	----------------------

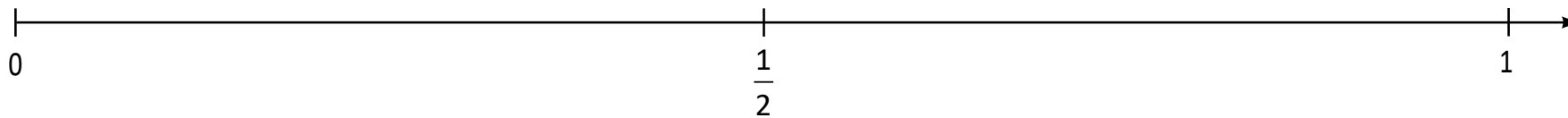

**Je situe ma fraction sur la droite numérique**

Ma fraction est plus près de \_\_\_\_\_ que de \_\_\_\_\_.

**Selon un modèle de longueur à l'aide de réglettes.**



**Selon un modèle d'aire à l'aide de blocs mosaïques.**

**Selon un modèle d'ensemble à l'aide des objets de mon choix.**

# Tableaux de nombres (1 à 20)

1	2	3	4	5	6	7	8	9	10
11	12	13	14	15	16	17	18	19	20



1	2	3	4	5	6	7	8	9	10
11	12	13	14	15	16	17	18	19	20



1	2	3	4	5	6	7	8	9	10
11	12	13	14	15	16	17	18	19	20



# Tableaux de nombres (1 à 30)

1	2	3	4	5	6	7	8	9	10
11	12	13	14	15	16	17	18	19	20
21	22	23	24	25	26	27	28	29	30



1	2	3	4	5	6	7	8	9	10
11	12	13	14	15	16	17	18	19	20
21	22	23	24	25	26	27	28	29	30



1	2	3	4	5	6	7	8	9	10
11	12	13	14	15	16	17	18	19	20
21	22	23	24	25	26	27	28	29	30



# Tableaux de nombres (1 à 100)

1	2	3	4	5	6	7	8	9	10
11	12	13	14	15	16	17	18	19	20
21	22	23	24	25	26	27	28	29	30
31	32	33	34	35	36	37	38	39	40
41	42	43	44	45	46	47	48	49	50
51	52	53	54	55	56	57	58	59	60
61	62	63	64	65	66	67	68	69	70
71	72	73	74	75	76	77	78	79	80
81	82	83	84	85	86	87	88	89	90
91	92	93	94	95	96	97	98	99	100



# Tableaux de nombres (0 à 99)

0	1	2	3	4	5	6	7	8	9
10	11	12	13	14	15	16	17	18	19
20	21	22	23	24	25	26	27	28	29
30	31	32	33	34	35	36	37	38	39
40	41	42	43	44	45	46	47	48	49
50	51	52	53	54	55	56	57	58	59
60	61	62	63	64	65	66	67	68	69
70	71	72	73	74	75	76	77	78	79
80	81	82	83	84	85	86	87	88	89
90	91	92	93	94	95	96	97	98	99





1	2	3	4	5	6	7	8	9	10
11	12	13	14	15	16	17	18	19	20
21	22	23	24	25	26	27	28	29	30
31	32	33	34	35	36	37	38	39	40
41	42	43	44	45	46	47	48	49	50
51	52	53	54	55	56	57	58	59	60
61	62	63	64	65	66	67	68	69	70
71	72	73	74	75	76	77	78	79	80
81	82	83	84	85	86	87	88	89	90
91	92	93	94	95	96	97	98	99	100

1	2	3	4	5	6	7	8	9	10
11	12	13	14	15	16	17	18	19	20
21	22	23	24	25	26	27	28	29	30
31	32	33	34	35	36	37	38	39	40
41	42	43	44	45	46	47	48	49	50
51	52	53	54	55	56	57	58	59	60
61	62	63	64	65	66	67	68	69	70
71	72	73	74	75	76	77	78	79	80
81	82	83	84	85	86	87	88	89	90
91	92	93	94	95	96	97	98	99	100

1	2	3	4	5	6	7	8	9	10
11	12	13	14	15	16	17	18	19	20
21	22	23	24	25	26	27	28	29	30
31	32	33	34	35	36	37	38	39	40
41	42	43	44	45	46	47	48	49	50
51	52	53	54	55	56	57	58	59	60
61	62	63	64	65	66	67	68	69	70
71	72	73	74	75	76	77	78	79	80
81	82	83	84	85	86	87	88	89	90
91	92	93	94	95	96	97	98	99	100

1	2	3	4	5	6	7	8	9	10
11	12	13	14	15	16	17	18	19	20
21	22	23	24	25	26	27	28	29	30
31	32	33	34	35	36	37	38	39	40
41	42	43	44	45	46	47	48	49	50
51	52	53	54	55	56	57	58	59	60
61	62	63	64	65	66	67	68	69	70
71	72	73	74	75	76	77	78	79	80
81	82	83	84	85	86	87	88	89	90
91	92	93	94	95	96	97	98	99	100

# Tableaux de nombres (1 à 120)

1	2	3	4	5	6	7	8	9	10
11	12	13	14	15	16	17	18	19	20
21	22	23	24	25	26	27	28	29	30
31	32	33	34	35	36	37	38	39	40
41	42	43	44	45	46	47	48	49	50
51	52	53	54	55	56	57	58	59	60
61	62	63	64	65	66	67	68	69	70
71	72	73	74	75	76	77	78	79	80
81	82	83	84	85	86	87	88	89	90
91	92	93	94	95	96	97	98	99	100
101	102	103	104	105	106	107	108	109	110
111	112	113	114	115	116	117	118	119	120





# Tableaux de nombres (1 à 200)

1	2	3	4	5	6	7	8	9	10
11	12	13	14	15	16	17	18	19	20
21	22	23	24	25	26	27	28	29	30
31	32	33	34	35	36	37	38	39	40
41	42	43	44	45	46	47	48	49	50
51	52	53	54	55	56	57	58	59	60
61	62	63	64	65	66	67	68	69	70
71	72	73	74	75	76	77	78	79	80
81	82	83	84	85	86	87	88	89	90
91	92	93	94	95	96	97	98	99	100
101	102	103	104	105	106	107	108	109	110
111	112	113	114	115	116	117	118	119	120
121	122	123	124	125	126	127	128	129	130
131	132	133	134	135	136	137	138	139	140
141	142	143	144	145	146	147	148	149	150
151	152	153	154	155	156	157	158	159	160
161	162	163	164	165	166	167	168	169	170
171	172	173	174	175	176	177	178	179	180
181	182	183	184	185	186	187	188	189	190
191	192	193	194	195	196	197	198	199	200



# Tableaux de nombres

## (1 à 100 - du bas vers le haut)

91	92	93	94	95	96	97	98	99	100
81	82	83	84	85	86	87	88	89	90
71	72	73	74	75	76	77	78	79	80
61	62	63	64	65	66	67	68	69	70
51	52	53	54	55	56	57	58	59	60
41	42	43	44	45	46	47	48	49	50
31	32	33	34	35	36	37	38	39	40
21	22	23	24	25	26	27	28	29	30
11	12	13	14	15	16	17	18	19	20
1	2	3	4	5	6	7	8	9	10



**Tableaux de nombres (1 à 200 - du bas vers le haut)**

200	199	198	197	196	195	194	193	192	191
190	189	188	187	186	185	184	183	182	181
180	179	178	177	176	175	174	173	172	171
170	169	168	167	166	165	164	163	162	161
160	159	158	157	156	155	154	153	152	151
150	149	148	147	146	145	144	143	142	141
140	139	138	137	136	135	134	133	132	131
130	129	128	127	126	125	124	123	122	121
120	119	118	117	116	115	114	113	112	111
110	109	108	107	106	105	104	103	102	101
100	99	98	97	96	95	94	93	92	91
90	89	88	87	86	85	84	83	82	81
80	79	78	77	76	75	74	73	72	71
70	69	68	67	66	65	64	63	62	61
60	59	58	57	56	55	54	53	52	51
50	49	48	47	46	45	44	43	42	41
40	39	38	37	36	35	34	33	32	31
30	29	28	27	26	25	24	23	22	21
20	19	18	17	16	15	14	13	12	11
10	9	8	7	6	5	4	3	2	1



## Tableaux de nombres (1 à 200 - du bas vers le haut)

200	199	198	197	196	195	194	193	192	191
190	189	188	187	186	185	184	183	182	181
180	179	178	177	176	175	174	173	172	171
170	169	168	167	166	165	164	163	162	161
160	159	158	157	156	155	154	153	152	151
150	149	148	147	146	145	144	143	142	141
140	139	138	137	136	135	134	133	132	131
130	129	128	127	126	125	124	123	122	121
120	119	118	117	116	115	114	113	112	111
110	109	108	107	106	105	104	103	102	101
100	99	98	97	96	95	94	93	92	91
90	89	88	87	86	85	84	83	82	81
80	79	78	77	76	75	74	73	72	71
70	69	68	67	66	65	64	63	62	61
60	59	58	57	56	55	54	53	52	51
50	49	48	47	46	45	44	43	42	41
40	39	38	37	36	35	34	33	32	31
30	29	28	27	26	25	24	23	22	21
20	19	18	17	16	15	14	13	12	11
10	9	8	7	6	5	4	3	2	1

Format 8,5 x 14



## Tableaux de nombres (1 à 200 - du bas vers le haut)

200	199	198	197	196	195	194	193	192	191
190	189	188	187	186	185	184	183	182	181
180	179	178	177	176	175	174	173	172	171
170	169	168	167	166	165	164	163	162	161
160	159	158	157	156	155	154	153	152	151
150	149	148	147	146	145	144	143	142	141
140	139	138	137	136	135	134	133	132	131
130	129	128	127	126	125	124	123	122	121
120	119	118	117	116	115	114	113	112	111
110	109	108	107	106	105	104	103	102	101
100	99	98	97	96	95	94	93	92	91
90	89	88	87	86	85	84	83	82	81
80	79	78	77	76	75	74	73	72	71
70	69	68	67	66	65	64	63	62	61
60	59	58	57	56	55	54	53	52	51
50	49	48	47	46	45	44	43	42	41
40	39	38	37	36	35	34	33	32	31
30	29	28	27	26	25	24	23	22	21
20	19	18	17	16	15	14	13	12	11
10	9	8	7	6	5	4	3	2	1

Format 11 x 17

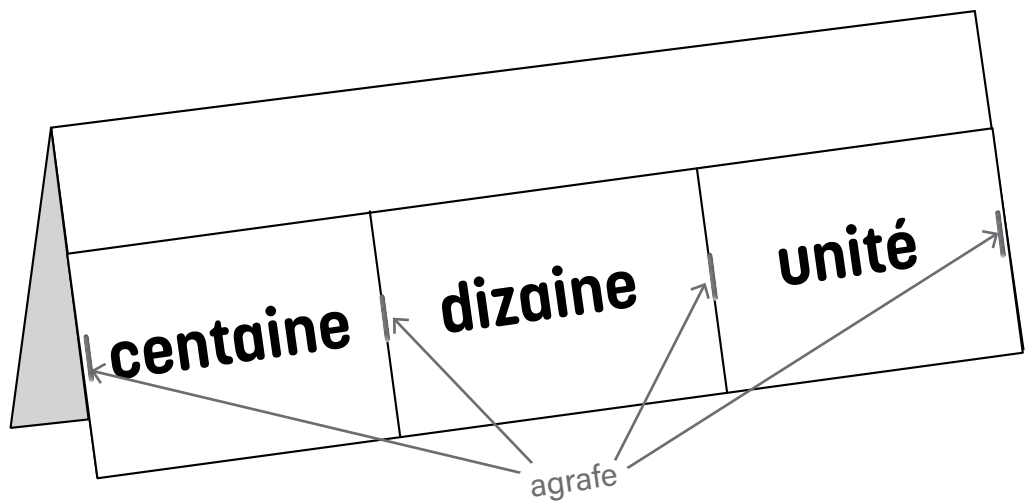
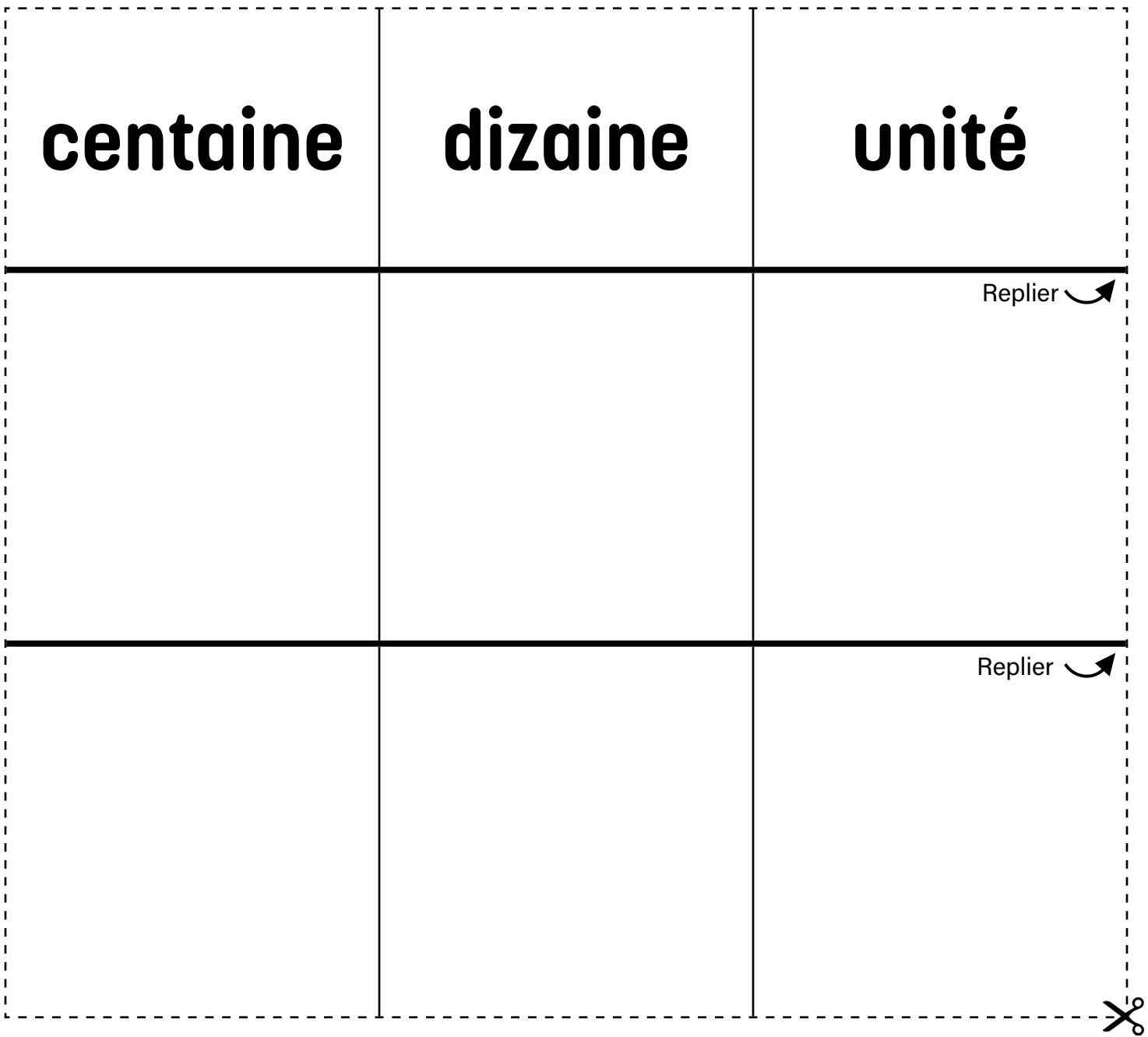

# Pochettes des valeurs de position (millier)

millier	centaine	dizaine	unité

Replier

Replier

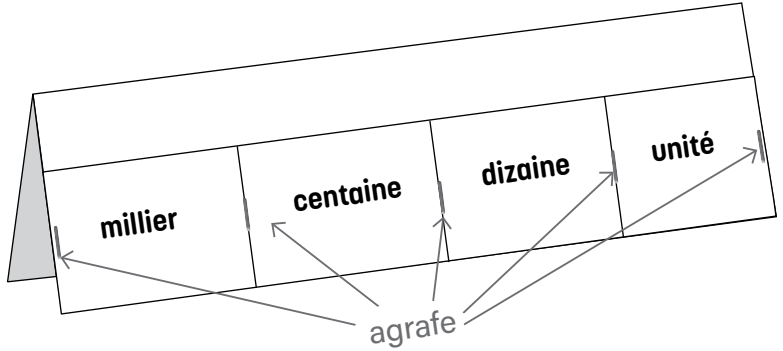

# Pochettes des valeurs de position (dizaine de millier)

Ma boîte à outils en mathématiques



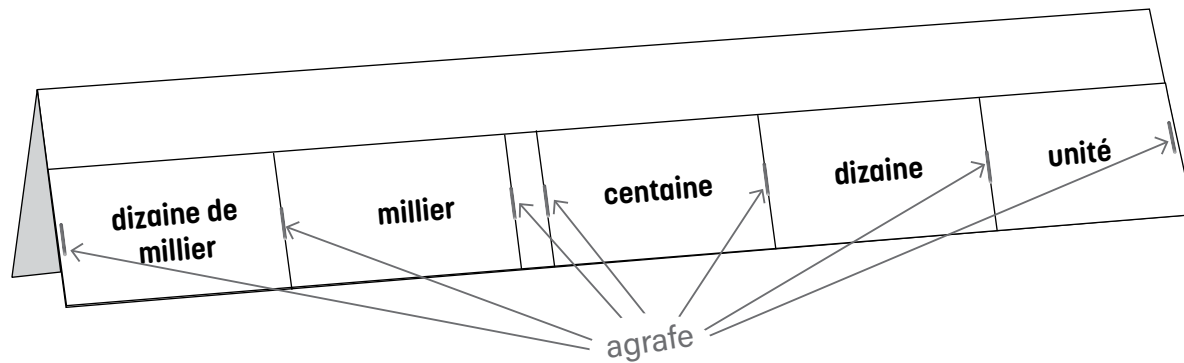

dizaine de millier	millier		centaine	dizaine	unité
					Replier ↷
					Replier ↷





# Pochettes des valeurs de position (de la centaine au dixième)

centaine	dizaine	unité	,	dixième
				Replier 
				Replier 
				

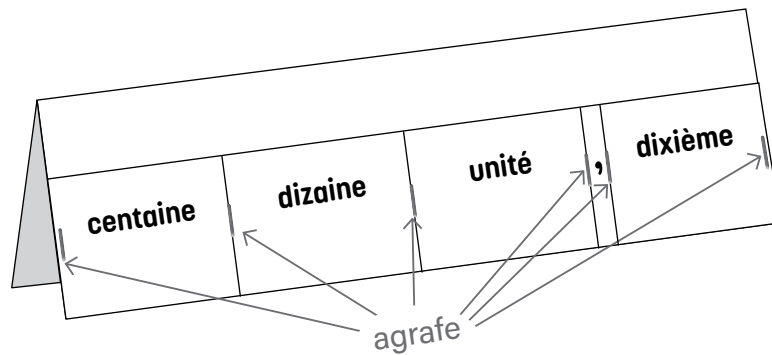

# Pochettes des valeurs de position (de la centaine au centième)



<b>centaine</b>	<b>dizaine</b>	<b>unité</b>	<b>,</b>	<b>dixième</b>	<b>centième</b>
					Replier ↷
					Replier ↷

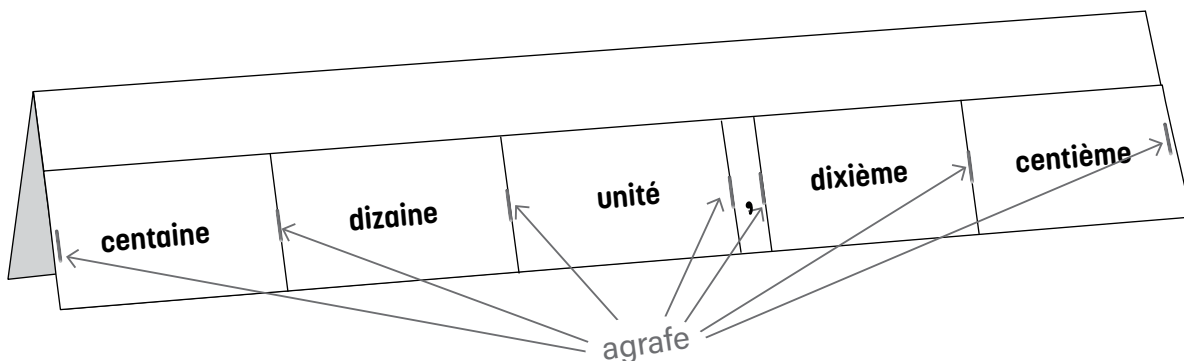

# Cartes de chiffres (0-9)

0	1	2	3	4
5	<u>6</u>	7	8	<u>9</u>



Valeur de position - Tapis des valeurs de position (100)  
Vides

**centaine**  
**100**

**dizaine**  
**10**

**unité**  
**1**

Valeur de position - Tapis des valeurs de position (1000)  
Vides

**millier**  
**1000**

**centaine**  
**100**

**dizaine**  
**10**

**unité**  
**1**



# Valeur de position - Tapis des valeurs de position (100) avec cartes à 10 points vides Imagés

**centaine**  
**100**

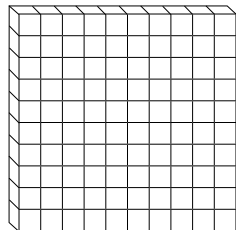

**dizaine**  
**10**



**unité**  
**1**

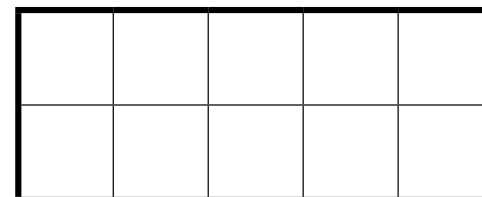
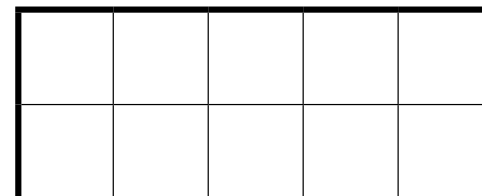

# Valeur de position - Tapis des valeurs de position (100) Imagés

**centaine**  
**100**

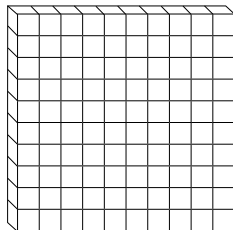

**dizaine**  
**10**



**unité**  
**1**



# Valeur de position - Tapis des valeurs de position (1000) Imagés

**millier**  
**1000**

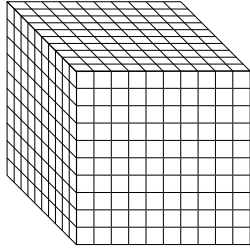

**centaine**  
**100**

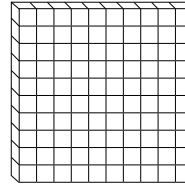

**dizaine**  
**10**





**unité**  
**1**





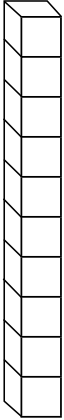

# Valeur de position - Tapis des valeurs de position

## Exemples

	unité	dixième
Représentation imagée		
Représentation symbolique	$\frac{10}{10} = 1$	$\frac{1}{10}$ ou $0,1$

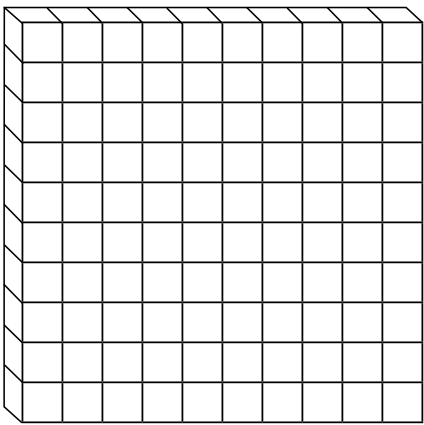
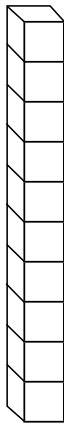

## Valeur de position - Tapis des valeurs de position

### Exemples

	unité	dixième	centième
<b>Représentation imagée</b>			
<b>Représentation symbolique</b>	$\frac{100}{100} = 1$	$\frac{10}{100} = \frac{1}{10}$ <p style="text-align: center;">ou</p> $0,1$	$\frac{1}{100} \text{ ou } 0,01$

# Valeur de position - Tapis des valeurs de position

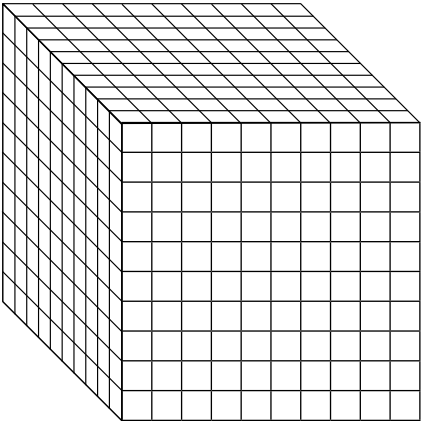
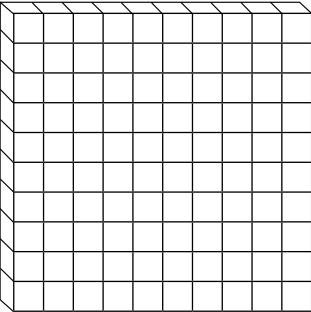
## Exemples

	millier	centaine	dizaine	unité
Représentation imagée				
Représentation symbolique	<b>1000</b>	<b>100</b>	<b>10</b>	<b>1</b>

Replier 

9 0 0 0 0



**Valeur de position - Tentes de nombres jusqu'à 9999  
(représentation symbolique)**

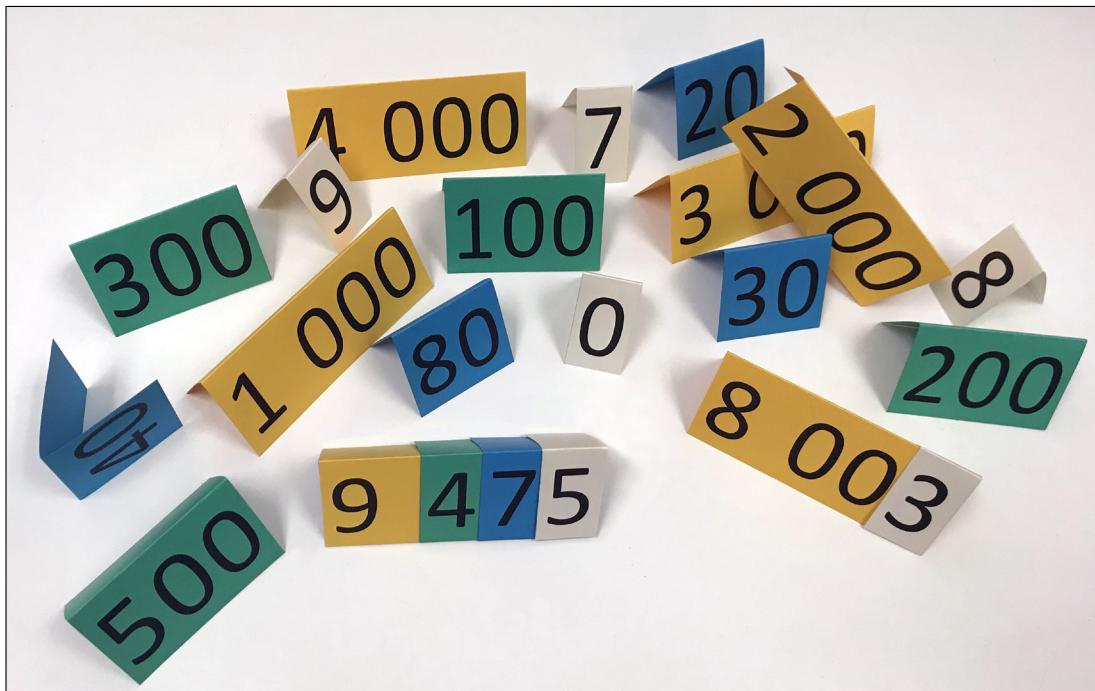

Replier 

8 0 0 0



Replier 

7 0 0 0



Replier 

6 0 0 0



Replier 

5 0 0 0



Replier 

4 0 0 0



Replier 

3 0 0 0



Replier 

2 0 0 0



Replier 

1 0 0 0





Replier 

9 0 0 8 0 0



Replier 

7 0 0 6 0 0



Replier 

500 400



Replier 

300 200





Replier 

90 80 70

Replier 

60 50 40



Replier 

30	20	10
----	----	----



--	--	--	--	--

Replier 

9	8	7	6	5
---	---	---	---	---



--	--	--	--	--

Replier 

4	3	2	1	0
---	---	---	---	---



# Liste partielle de matériel de manipulation et de modèles – Maternelle à la 4<sup>e</sup> année

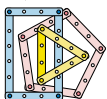
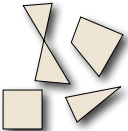
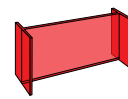
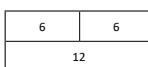
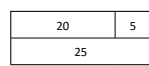
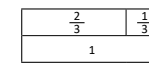

Maternelle	1 <sup>re</sup> année	2 <sup>e</sup> année	3 <sup>e</sup> année	4 <sup>e</sup> année
<ul style="list-style-type: none"> <li>Bac à sable ou bac à eau</li> <li>Balance</li> <li>Bandes de nombres cachés</li> <li>Blocs logiques</li> <li>Blocs mosaïques</li> <li>Cartes à 5 et à 10 points</li> <li>Cubes emboîtables/cubes Unifix</li> <li>Dés</li> <li>Domino</li> <li>Jetons</li> <li>Objets à 3 dimensions</li> <li>Réglettes Cuisenaire</li> <li>Roulettes</li> <li>Tuiles de couleur</li> <li>Variété de collections</li> </ul> 	<ul style="list-style-type: none"> <li>Balance</li> <li>Bandes de nombres cachés</li> <li>Bâtonnets géométriques</li> <li>Blocs logiques</li> <li>Blocs mosaïques</li> <li>Dés, dominos</li> <li>Géoplans</li> <li>Objets à 3 dimensions</li> <li>Réglettes Cuisenaire</li> <li>Roulettes</li> <li>Tableau de 100</li> <li>Tuiles de couleur</li> <li>Variété de collections</li> </ul> 	<ul style="list-style-type: none"> <li>Balance</li> <li>Bandes de nombres cachés</li> <li>Bâtonnets géométriques</li> <li>Blocs de base 10</li> <li>Blocs logiques</li> <li>Blocs mosaïques</li> <li>Cubes emboîtables/cubes Unifix</li> <li>Dés, dominos</li> <li>Cartes de polygones réguliers et irréguliers</li> <li>Objets à trois dimensions</li> <li>Géoplans</li> <li>Réglettes Cuisenaire</li> <li>Roulettes</li> <li>Tuiles de couleur</li> <li>Variété de collections</li> </ul> 	<ul style="list-style-type: none"> <li>Balance</li> <li>Bandes de nombres cachés</li> <li>Bâtonnets géométriques</li> <li>Blocs de base dix</li> <li>Blocs logiques</li> <li>Blocs mosaïques</li> <li>Cartes de polygones réguliers et irréguliers</li> <li>Cubes emboîtables/cubes Unifix</li> <li>Dés, dominos</li> <li>Géoplans</li> <li>Objets à trois dimensions</li> <li>Pièces de monnaie et billets</li> <li>Règles</li> <li>Réglettes Cuisenaire</li> <li>Roulettes</li> <li>Tuiles de couleur</li> <li>Variété de collections</li> </ul> 	
<ul style="list-style-type: none"> <li>Calendrier</li> <li>Tableau « partie-partie-tout »</li> <li>Reconnaissance globale : carte de nombres (1 à 10), carte à points, constellation, carte de doigts, dé</li> <li>Variété de droites numériques (horizontale et verticale, ouverte et fermée)</li> <li>Dénombrement : corde à billes, abaque</li> </ul>	<ul style="list-style-type: none"> <li>Base dix : carte à 10 points, corde à billes</li> <li>Calendrier</li> <li>Carte de nombres (1 à 100)</li> <li>Dénombrement et calcul : corde à billes, abaque, tableau de nombres, carte à points simple et double</li> <li>Reconnaissance globale : carte à points, constellation, dé, domino</li> <li>Tableau « partie-partie-tout »</li> </ul>  <p>Variété de droites numériques (horizontale et verticale, ouverte et fermée)</p>	<ul style="list-style-type: none"> <li>Base dix : carte à 10 points, tapis de valeur de position, tente de nombres jusqu'à 100</li> <li>Calendrier</li> <li>Calcul : corde à billes, abaque, tableau de nombres, carte à points simple et double</li> <li>Carte de nombres (1 à 100)</li> <li>Tableau « partie-partie-tout »</li> </ul>  <p>Variété de droites numériques (horizontale et verticale, ouverte et fermée)</p>	<ul style="list-style-type: none"> <li>Base dix : carte à 10 points, tapis de valeur de position, tente de nombres jusqu'à 1000</li> <li>Calcul : tableau de nombres, carte à points simple et double, variété de droites numériques (horizontale et verticale, ouverte et fermée)</li> <li>Carte de nombres (1 à 1000)</li> <li>Tableau de nombres</li> <li>Tableau partie-partie-tout</li> </ul> 	<ul style="list-style-type: none"> <li>Base dix : blocs de base dix, tapis de valeur de position, tentes de nombres jusqu'à 10 000</li> <li>Calcul : arrangement rectangulaire, tableau de nombres, variété de droites numériques (horizontale et verticale, ouverte et fermée)</li> <li>Fraction : carte à 10 points, carte de fractions et modèles de région, de mesure (longueur et volume) ou d'ensemble</li> <li>Tableau de nombres</li> <li>Tableau « partie-partie-tout »</li> </ul> 