



# Senior 4 Physics (40S)

A Foundation for  
Implementation

---

# ***SENIOR 4 PHYSICS (40S)***

*A Foundation for Implementation*

**2005**

Manitoba Education, Citizenship and Youth

---

---

**Manitoba Education, Citizenship and Youth Cataloguing in Publication Data**

530.0712      Senior 4 physics : a foundation for implementation

ISBN 0-7711-3438-X

1. Physics—Study and teaching (Secondary) — Manitoba. 2. Physics—Curricula. 3. Physics—Study and teaching (Secondary). I. Manitoba. Manitoba Education, Citizenship and Youth.

Copyright © 2005, the Crown in Right of Manitoba as represented by the Minister of Education, Citizenship and Youth. Manitoba Education, Youth and Citizenship, School Programs Division, 1970 Ness Avenue, Winnipeg, Manitoba R3J 0Y9.

Every effort has been made to acknowledge original sources and to comply with copyright law. If cases are identified where this has not been done, please notify Manitoba Education, Citizenship and Youth. Errors or omissions will be corrected in a future edition. Sincere thanks to the authors and publishers who allowed their original material to be adapted or reproduced.

---

# ACKNOWLEDGEMENTS

Manitoba Education, Citizenship and Youth gratefully acknowledges the contributions of the following individuals in the development of *Senior 4 Physics (40S): A Foundation for Implementation*.

## Principal Writer

Don Metz, Ph.D.                      Education Program                      University of Winnipeg

## Editor

Pat Sanders                      Freelance Editor

## Physics Education and Curriculum Advisor

Prof. Arthur O. Stinner              Faculty of Education                      University of Manitoba

## Contributing Writers

Steven Boyko	St. Boniface Diocesan H.S.	Catholic Schools Commission
Dennis Kuzenko	Grant Park H.S.	Winnipeg S.D.
John Murray	Science Consultant	Manitoba Education, Citizenship and Youth

## Members of the Development Team

Jeff Anderson	Collège Jeanne Sauvé	Division scolaire Louis-Riel
Alphonse Bernard	Collège Louis Riel	Division scolaire franco-manitobaine
Steven Boyko	St. Boniface Diocesan H.S.	Catholic Schools Commission
Jason Braun	John Taylor Collegiate	St. James-Assiniboia S.D.
Elizabeth Kozoriz	Daniel MacIntyre Collegiate	Winnipeg S.D.
Gary Myden	Hapnot Collegiate Institute	Flin Flon S.D.
Barry Panas	River East Collegiate	River East-Transcona S.D.
Bryan Reimer	Arthur Meighen Collegiate	Portage la Prairie S.D.
Dr. Rodelyn Stoeber	Institut collégial Vincent Massey	Division scolaire Pembina Trails

## Graphics Design

Barry Panas	River East Collegiate	River East-Transcona S.D.
-------------	-----------------------	---------------------------

## Kindergarten to Senior 4 Science Steering Committee

Ron Banister	Manitoba Teachers' Society	Winnipeg S.D.
Sharon Burns	Manitoba Association of Parent Councils	
Randy Cielen	Science Teachers' Association of Manitoba	Transcona-Springfield S.D. (until September 2002)
Terry DeRoo	Trades Department	Assiniboine Community College (until September 2002)
David Graham		Red River College

**Kindergarten to Senior 4 Science Steering Committee (continued)**

Kay Harvey	Manitoba Association of School Trustees	Whiteshell S.D.
Ron Hildebrand	Manitoba Association of School Superintendents	River East-Transcona S.D.
Veronica Klassen	Eastwood Elementary School	Mystery Lake S.D.
Jan Pazdzierski	McIsaac School	Flin Flon S.D.
Rick Pokrant	Science Teachers' Association of Manitoba	River East-Transcona S.D. (since October 2002)
Dr. G. Gordon Robinson	Faculty of Science	University of Manitoba (until September 2002)
Rick Skarban	Councils for School Leadership	Mystery Lake S.D.
Deb Spelchak	Glenlawn Collegiate	Division scolaire Louis-Riel
Dr. Dawn L. Sutherland	Education Program	University of Winnipeg

**School Programs Division Staff**

Lee-Ila Bothe	Coordinator	Document Production Services Instruction, Curriculum and Assessment
Lynn Harrison	Desktop Publisher	Document Production Services Instruction, Curriculum and Assessment
John Murray	Project Leader	Development Unit Instruction, Curriculum and Assessment
Aileen Najduch	Project Manager	Development Unit Instruction, Curriculum and Assessment
Jan Oakley	Publications Editor	Document Production Services Instruction, Curriculum and Assessment

**Bureau de l'éducation française Division Staff**

Jean-Vianney Auclair	Director	Bureau de l'éducation française
Daniele Dubois-Jacques	Consultant	Bureau de l'éducation française

# CONTENTS

## Acknowledgements *iii*

## Introduction *1*

- Background *1*
- Vision for Scientific Literacy *1*
- The Vision of *Senior 4 Physics: A Foundation for Implementation* *1*
- Goals for Canadian Science Education *2*
- Beliefs about Learning, Teaching, and Assessing Science *2*
- Changing Emphases in Science Education Content Delivery *3*
- Changing Emphases to Promote Inquiry *3*

## Section 1: Manitoba Foundations for Scientific Literacy

- The Five Foundations *3*
- Nature of Science and Technology *4*
- Science, Technology, Society, and the Environment (STSE) *6*
- Scientific and Technological Skills and Attitudes *9*
- Essential Science Knowledge *12*
- The Unifying Concepts *13*
- Kindergarten to Senior 3 Physics Topic Chart *15*

## Section 2: Implementation

- The Senior Years Student and the Science Learning Environment *3*
- Characteristics of Senior 4 Learners *3*
- Effective Teaching in Physics: What the Research Says to Teachers *14*
- Unit Development in Physics *16*
- A View of Physics Education: Toward Modes of Representation *17*
- The Modes of Representation *18*
- The Importance of the Modes of Representation *21*
- Toward an Instructional Philosophy in Physics *23*

## Section 3: Assessment in Senior 4 Physics

- Characteristics of Effective Assessment *4*
- Types of Assessment *10*
- Assessment Strategies *11*

## **Section 4: Document Organization**

Guide to Reading Specific Learning Outcomes and Document Format	3
Document Format	4
Guide to Reading Specific Learning Outcomes	6
Skills and Attitudes Outcomes Overview	7
Specific Learning Outcomes Overview	9

## **Unit 1: Mechanics**

Topic 1.1: Kinematics	3
Topic 1.2: Dynamics	15
Topic 1.3: Momentum	25
Topic 1.4: Projectile Motion	37
Topic 1.5: Circular Motion	47
Topic 1.6: Work and Energy	59

## **Unit 2: Fields**

Topic 2.1: Exploration of Space	3
Topic 2.2: Low Earth Orbit	17
Topic 2.3: Electric and Magnetic Fields	37

## **Unit 3: Electricity**

Topic 3.1: Electric Circuits	3
Topic 3.2: Electromagnetic Induction	19

## **Unit 4: Medical Physics**

Topic 4.1: Medical Physics	3
----------------------------	---

## **Appendices**

### **Appendix 1: Mechanics**

1.1: Derivations for Constant Motion	3
1.2: Category Concept Map	7
1.3: Kinematics Problem Set	8
1.4: Inclined Planes	12
1.5: Momentum and Impulse	16
1.6: Collisions in Two Dimensions	18
1.7: Projectiles	22
1.8: Force-Work Relationships	24
1.9: Centrifuge Demonstration	26

**Appendix 2: Fields**

- 2.1: Charges Moving Between or Through Parallel Plates 27
- 2.2: Space Exploration Issues 29

**Appendix 3: Electricity**

- 3.1: The Historical Development of Ohm’s Law 31
- 3.2: Power, Resistance, and Current 35
- 3.3: Kirchoff’s Contribution 39
- 3.4: Electromagnetic Induction 45
- 3.5: Faraday’s Law 46

**Appendix 4: Medical Physics**

- 4.1: “Get a Half-Life” 49
- 4.2: Alpha Decay 51
- 4.3: Beta Decay 52
- 4.4: Gamma Radiation 53
- 4.5: Radioisotopes and Their Uses in the Diagnosis or Treatment of Illness 54

**Appendix 5: Developing Assessment Rubrics in Science**

- The Nature, Purpose, and Sources of Assessment Rubrics for Science 55
- Developing Rubrics in Collaboration with Students 58

**Appendix 6: Assessment Rubrics**

- Rubric for the Assessment of Class Presentations 63
- Rubric for the Assessment of a Research Project 64
- Rubric for the Assessment of a Decision-Making Process Activity 65
- Lab Report Assessment 67
- Observation Checklist—Scientific Inquiry: Conducting a Fair Test 68
- Rubric for Student Presentation 69
- Rubric for Research Skills 70

**Appendix 7: General Learning Outcomes 71****Appendix 8: Specific Learning Outcomes 73****Bibliography**



---

# INTRODUCTION

## Background

*Senior 4 Physics: A Foundation for Implementation* presents student learning outcomes for Senior 4 Physics. These learning outcomes are the same for students in English, French Immersion, Français, and Senior Years Technology Education programs, and result from a partnership involving two divisions of Manitoba Education, Citizenship and Youth: School Programs Division and Bureau de l'éducation française. Manitoba's science student learning outcomes for Senior 4 Physics are based, in part, on those within the *Common Framework of Science Learning Outcomes K to 12* (Council of Ministers of Education, Canada) and on those developed as components of the 1998 Transitional Curricula. The former, commonly referred to as the *Pan-Canadian Science Framework*, was initiated under the Pan-Canadian Protocol for Collaboration on School Curriculum (1997), and was developed by educators from Manitoba, Saskatchewan, Alberta, British Columbia, the Northwest Territories, the Yukon Territory, Ontario, and the Atlantic provinces.

*Senior 4 Physics: A Foundation for Implementation* provides the basis for learning, teaching, and assessing physics in Manitoba. It also serves as a starting point for future development of curriculum support documents, related teacher-support materials, learning resources, assessment tools, and professional learning for teachers. This document also complements the *Pan-Canadian Science Framework* by providing support for its implementation, including suggestions for instruction and assessment.

## Vision for Scientific Literacy

Global interdependence; rapid scientific and technological innovation; the need for a sustainable environment, economy, and society; and the pervasiveness of science and technology in daily life reinforce the importance of scientific literacy. Scientifically literate individuals can more effectively interpret information, solve problems, make informed decisions, accommodate change, and achieve new understandings. Science education makes possible the development of the foundations necessary to develop a functional **scientific literacy**, and assists in building stronger futures for Canada's young people.

The *Pan-Canadian Science Framework* and *Senior 4 Physics: A Foundation for Implementation* are designed to support and promote an attainable and realistic vision for scientific literacy. Student learning outcomes are concise descriptions of the knowledge and skills (and attitudes) that students are expected to learn in a course or grade level in a subject area (Manitoba Education and Training, *A Foundation for Excellence*, 1995).

## The Vision of Senior 4 Physics: A Foundation for Implementation

The *Pan-Canadian Science Framework* was guided by the vision that all Canadian students, irrespective of gender or cultural background, will have an opportunity to develop their own individual approaches to scientific literacy. Scientific literacy is an ever-evolving combination of the science-related attitudes, skills, and knowledge students need to develop inquiry, problem-solving, and decision-making abilities to become lifelong learners. No less important, scientific literacy should maintain in students a sense of curiosity, wonder, awe, and abiding respect for the world around them.

Diverse learning experiences based on the *Pan-Canadian Science Framework* will provide students with many opportunities to explore, analyze, evaluate, synthesize, appreciate, and understand the interrelationships among science, technology, society, and the environment that will affect their personal lives, careers, and their future (Council of Ministers of Education, Canada, 1997).

### **Goals for Canadian Science Education**

Several goals promoting the achievement of scientific literacy within Canadian science education were developed as part of the *Pan-Canadian Science Framework*. These goals are addressed through the Manitoba science curricula. It is hoped that science education will

- encourage students at all levels to develop a rational sense of wonder and curiosity about scientific and technological endeavours;
- enable students to use science and technology to acquire new knowledge and solve problems, so they may improve the quality of their own lives and the lives of others;
- prepare students to critically address science-related societal, economic, ethical, and environmental issues;
- provide students with a proficiency in science that creates opportunities for them to pursue progressively higher levels of advanced study, preparing them for science-related occupations, and engaging them in science-related activities appropriate to their interests and abilities; and
- develop in students of varying aptitudes and interests a knowledge of the wide variety of careers related to science, technology, and support for the natural and human environments.

### **Beliefs about Learning, Teaching, and Assessing Science**

To promote a rational, achievable approach to developing scientific literacy among future citizens, it is crucial to recognize how students learn, how science can best be taught, and how learning can be assessed. Students are curious, active learners who have individual interests, abilities, and needs. They come to school with various personal and cultural experiences and prior knowledge that generate a range of attitudes and beliefs about science and life, and connections between these realms.

Students learn most effectively—in a Piagetian sense—when their study of science is rooted in concrete learning experiences related to a particular context or situation, and applied to their world of experiences where appropriate. Ideas and understandings that students develop should be progressively extended and reconstructed as students grow in their experiences and in their ability to conceptualize more deeply. Learning involves the process of linking newly constructed understandings *with* prior knowledge, and then adding new contexts and experiences to current understandings. It is increasingly important that physics educators draw professional attention to how fundamental research in learning theory will affect their efforts in the science classroom.

## Changing Emphases in Science Education Content Delivery\*

The *National Science Education Standards* envision change throughout the system. The science content standards [or student learning outcomes] encompass the following changes in emphases:

LESS EMPHASIS ON	MORE EMPHASIS ON
Knowing scientific facts and information	Understanding scientific concepts and developing abilities of inquiry
Studying subject matter disciplines (physical, life, earth sciences) for their own sake	Learning subject matter disciplines in the context of inquiry, technology, science in personal and social perspectives, and history and nature of science
Separating science knowledge and science process	Integrating all aspects of science content
Covering many science topics	Studying a few fundamental science concepts
Implementing inquiry as a set of processes	Implementing inquiry as instructional strategies, abilities, and ideas to be learned

\* Reprinted with permission from *National Science Education Standards*. Copyright © 1996 by the National Academy of Sciences. Courtesy of the National Academies Press, Washington, DC.

## Changing Emphases to Promote Inquiry

LESS EMPHASIS ON	MORE EMPHASIS ON
Activities that demonstrate and verify science content	Activities that investigate and analyze science questions
Investigations confined to one class period	Investigations over extended periods of time
Process skills out of context	Process skills in context
Individual process skills such as observation or inference	Using multiple process skills—manipulation, cognitive, procedural
Getting an answer	Using evidence and strategies for developing or revising an explanation
Science as exploration and experiment	Science as argument and explanation
Providing answers to questions about science content	Communicating science explanations
Individuals and groups of students analyzing and synthesizing data without defending a conclusion	Groups of students often analyzing and synthesizing data after defending conclusions
Doing a few investigations in order to leave time to cover large amounts of content	Doing more investigations in order to develop understanding, ability, values of inquiry, and knowledge of science content
Concluding inquiries with the result of the experiment	Applying the results of experiments to scientific arguments and explanations
Management of materials and equipment	Management of ideas and information
Private communication of student ideas and conclusions to teacher	Public communication of student ideas and work to classmates

Development of increased scientific literacy is supported by instructional environments that engage students in the following:

- **SCIENCE INQUIRY:** Students are encouraged to converse, ask penetrating questions, and then seek to explore their own constructed explanations alongside scientific explanations through guided research, writing, and planned investigations.
- **PROBLEM SOLVING:** Students apply their acquired expertise and knowledge in novel, oftentimes unforeseeable, ways.
- **DECISION MAKING:** As students identify rich, large-context problems, questions, or issues related to the human and robotic exploration of the universe, they pursue new knowledge that will assist them in making informed, rational, defensible decisions that are rooted in the societal and humanistic domains within which science practice operates.
- **THE NATURE OF SCIENCE:** Students appreciate and value the understanding that science operates with the consent of personal, social, political, environmental, and multicultural orientations of the global society. Moreover, there are consequences when science circumvents its responsibilities among these societal contexts.
- **SCIENCE-RELATED SKILLS:** Examples of these skills include initiating, planning, performing, recording, analyzing, interpreting, communicating, and team building. All these skills have central importance in learning the dimensions of science. It is important that science students of today not be taught the myth of a single, specifiable “scientific method” that leads to a superior “truth” about the material world. If there is indeed an objective “reality,” philosophers of science often agree that it may be difficult to define, or perhaps be unknowable. Nevertheless, the methods of science systematically permit new knowledge domains to be constructed, and that knowledge is often robust and durable.
- **SCIENCE CONTENT KNOWLEDGE:** Transmission of science content is no longer considered to be the primary outcome of science teaching. In addition, science knowledge is actively constructed from existing and emerging personal and social knowledge. Creative, integrative, and interdisciplinary linkages should be balanced with the traditional “disciplinary focus” of teaching and learning in physics. Unifying concepts among traditional, bounded, restricted disciplines now give way to, and add form and substance to, new views of exploration among the sciences that are holistic and interdisciplinary.

It is through exposure to these areas that students discover the significance of science in their lives and come to appreciate the interrelatedness of science, technology, society, and the environment. Each can be a starting point for science learning, and may encompass the exploration of new ideas, the development of specific investigations, and the application of ideas that are learned.

To achieve the vision of a scientific literacy for all, according to personal interests and inclinations, students could become increasingly more engaged in the planning, development, and evaluation of their own learning experiences. They should have the opportunity to work co-operatively with other students, to initiate investigations, to communicate their findings, and to complete projects that demonstrate their learning in a personal, though peer-reviewed, manner. At the beginning of instructional design, teachers

and students should identify expected student learning outcomes and establish performance criteria. It is important that these criteria correspond with provincial student learning outcomes. This communication between students and teachers helps to identify clearly what needs to be accomplished, thereby assisting in the learning process (see the rubrics in Appendix 6).

When students are aware of expected outcomes, they will be more focussed on their learning, and may be more likely to assess their own progress. Furthermore, they can participate in creating appropriate assessment and evaluation criteria. Assessment methods must be valid, reliable, and fair to students.

## NOTES

---

## ***SECTION 1: MANITOBA FOUNDATIONS FOR SCIENTIFIC LITERACY***

The Five Foundations	3
Nature of Science and Technology	4
Science, Technology, Society, and the Environment (STSE)	6
Scientific and Technological Skills and Attitudes	9
Essential Science Knowledge	12
The Unifying Concepts	14
Kindergarten to Senior 3 Topic Chart	15

---

# MANITOBA FOUNDATIONS FOR SCIENTIFIC LITERACY

## The Five Foundations

To develop scientifically literate students, Manitoba science curricula are built upon five foundations for scientific literacy (Figure 1) that have been adapted from the *Pan-Canadian Science Framework* to address the needs of Manitoba students. These include:

- Nature of Science and Technology
- Science, Technology, Society, and the Environment (STSE)
- Scientific and Technological Skills and Attitudes
- Essential Science Knowledge
- Unifying Concepts

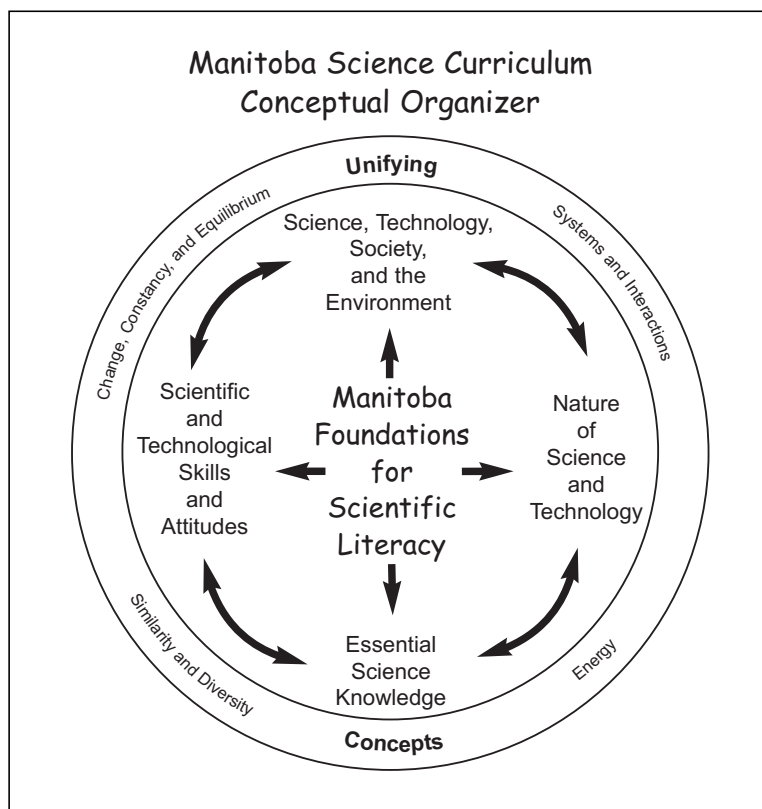

**Figure 1:** Manitoba Science Curriculum Conceptual Organizer

In the following pages, each foundation is described, representing the goals of science learning in Kindergarten to Senior 4. These foundations led to the development of the general learning outcomes contained in *Senior 4 Physics: A Foundation for Implementation* (2005).



## Nature of Science and Technology

Students learn that science and technology are creative human activities with long histories in all cultures. Science is a way of learning about the universe. This learning stems from curiosity, creativity, imagination, intuition, exploration, observation, replication of experiments, interpretation of evidence, and debate over that evidence and its interpretations. Scientific activity involves predicting, interpreting, and explaining natural and human-made phenomena. Many historians, sociologists, and philosophers of science presently argue that there is no definable, set procedure for conducting a scientific investigation. Rather, they see science as driven by a combination of theoretical concerns, knowledge, experiments, and processes anchored in the physical world.

Producing science knowledge is an intrinsically collective endeavour. There is no such thing as stand-alone science done in isolation. Scientists submit models and solutions for the assessment of their peers, who judge their logical, rational and experimental soundness through reference to the body of existing knowledge and modes of representation (Larochelle and Désautels, 1992).

Scientific theories are being tested, modified, and refined continually as new knowledge and theories supersede existing knowledge bases. Scientific debate, both on new observations and on hypotheses that challenge accepted knowledge, involves many participants with diverse backgrounds. This highly complex interplay, which has occurred throughout history, is animated by theoretical discussions; experimentation; social, cultural, economic, and political influences; personal biases; and the need for peer recognition and acceptance. Students will realize that while some of our understandings about how the world works are due to revolutionary scientific developments, many of our understandings result from the steady and gradual accumulation of knowledge. History demonstrates, however, that great advances in scientific thought have completely uprooted certain disciplines, transplanting practitioners and theoreticians alike into an entirely new set of guiding assumptions. Such scientific revolutions, as discussed by Thomas S. Kuhn in his influential *The Structure of Scientific Revolutions* (1970), constitute exemplars that can energize the science teaching enterprise—particularly in physics education.

Technology results mainly from proposing solutions to problems arising from human attempts to adapt to the external environment. Technology may be regarded as “a tool or machine; a process, system, environment, epistemology, and ethic; the systematic application of knowledge, materials, tools, and skills to extend human capabilities...” (Manitoba Education and Training, *Technology as a Foundation Skill Area: A Journey Toward Information Technology Literacy*, 1998). “Technology” refers to much more than the knowledge and skills related to computers and their applications. Technology is based on the knowledge of concepts and skills from other disciplines (including science), and is the application of this knowledge to meet an identified need or to solve a problem using materials, energy, and tools (including computers). Technology also has an influence on processes and systems, on society, and on the ways people think, perceive, and define their world.

*Senior 4 Physics* is designed to emphasize both the distinctions and relationships between science and technology. Figure 2 illustrates how science and technology differ in purpose, procedure, and product, while at the same time relate to each other.

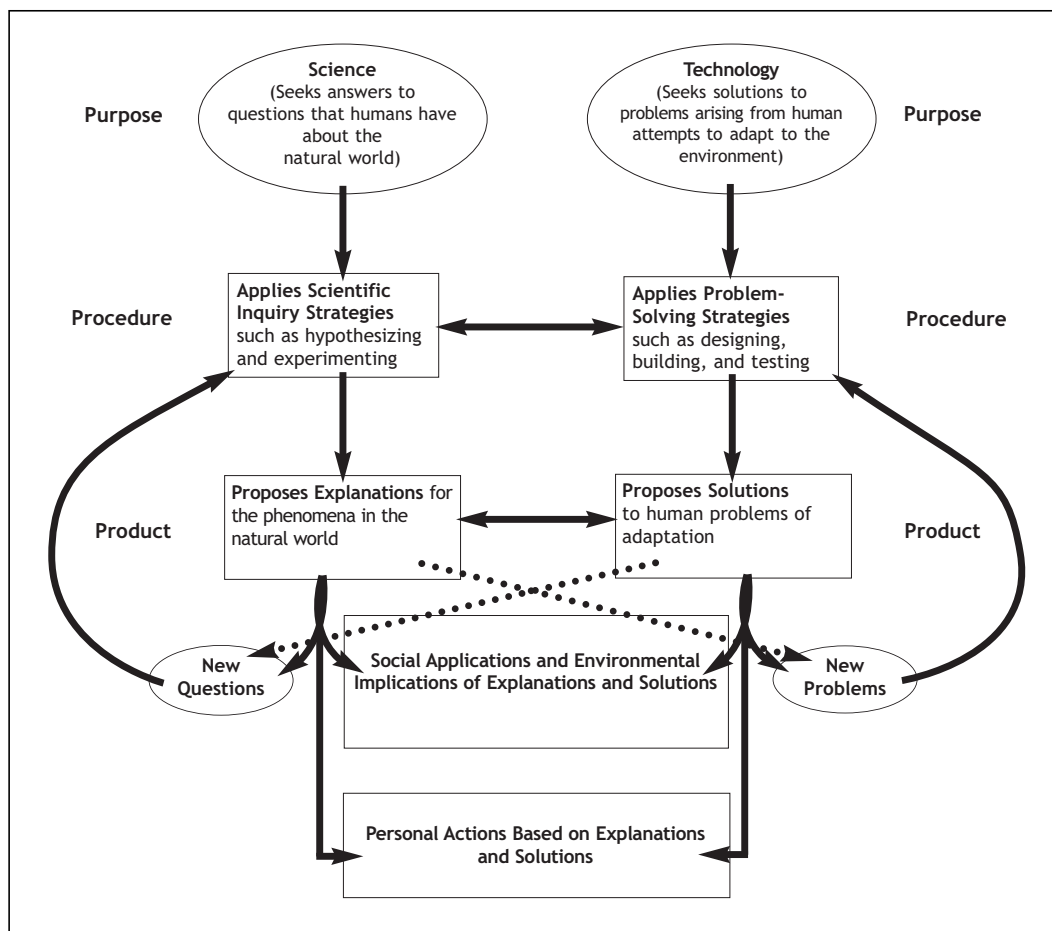

**Figure 2:** Science and Technology: Their Nature and Interrelationships\*

\* Adapted from Bybee, Rodger W., et al., *Science and Technology Education for the Elementary Years: Frameworks for Curriculum and Instruction*. Copyright © 1989 The NETWORK Inc.

The following General Learning Outcomes (GLOs) have been developed to further define expectations related to this foundation area (for a complete listing of Science GLOs, see Appendix 7).

### **Nature of Science and Technology General Learning Outcomes**

As a result of their Senior Years science education, students will

- A1. recognize both the power and limitations of science as a way of answering questions about the world and explaining natural phenomena
- A2. recognize that scientific knowledge is based on evidence, models, and explanations, and evolves as new evidence appears and new conceptualizations develop
- A3. distinguish critically between science and technology in terms of their respective contexts, goals, methods, products, and values
- A4. identify and appreciate contributions made by women and men from many societies and cultural backgrounds toward increasing our understanding of the world and in bringing about technological innovations
- A5. recognize that science and technology interact with and advance one another

### **Science, Technology, Society, and the Environment (STSE)**

Understanding the complex interrelationships among STSE is an essential component of fostering increased scientific literacy. By studying the historical context, students come to appreciate ways in which cultural and intellectual traditions have influenced the questions and methodologies of science, and how science, in turn, has influenced the wider world of ideas.

Today, most scientists work in industry, where projects are more often driven by societal and environmental needs than by pure research. Many technological solutions have evoked complex social and environmental issues. Students recognize the potential of scientific literacy to inform and empower decision making of individuals, communities, and society as a whole.

Scientific knowledge is necessary, but not sufficient, for understanding the relationships among science, technology, society, and the environment. To understand these relationships fully, it is essential that students consider the values related to science, technology, society, and the environment.

As a component of achieving scientific literacy, students must also develop an appreciation for the importance of sustainable development. Sustainable development is a decision-making model that considers the needs of both present and future generations, and integrates and balances the impact of economic activities, the environment, and the health and well-being of the community (see Figure 3). Educators are encouraged to consult *Education for a Sustainable Future* (Manitoba Education and Training, 2000), which outlines ways of incorporating precepts, principles, and practices to foster appropriate learning environments that would help direct students toward a sustainable future. The document can be accessed online at: <<http://www.edu.gov.mb.ca/ks4/docs/support/future/sustainededucation.pdf>>.

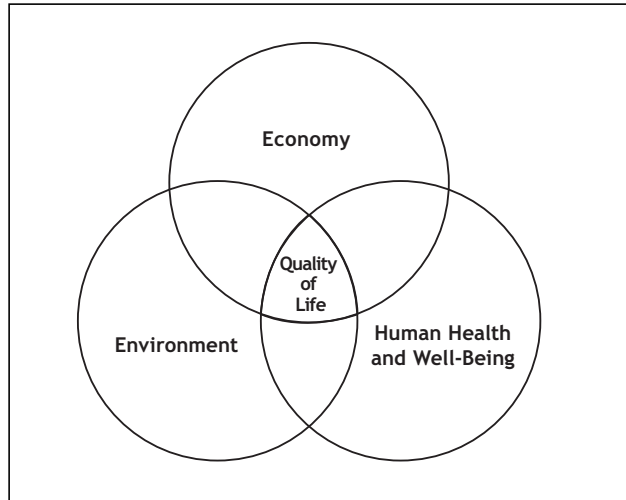

**Figure 3:** Sustainable Development

**Sustainable human health and well-being** is characterized by people coexisting harmoniously within local, national, and global communities, and with nature. A sustainable society is one that is physically, psychologically, spiritually, and socially healthy. The well-being of individuals, families, and communities is of considerable importance.

A **sustainable environment** is one in which the life-sustaining processes and natural resources of the Earth are conserved and regenerated.

A **sustainable economy** is one that provides equitable access to resources and opportunities. It is characterized by development decisions, policies, and practices that respect cultural realities and differences, and do not exhaust the Earth's resources. A sustainable economy is evident when decisions, policies, and practices are carried out to minimize their impact on the Earth's resources and to maximize the regeneration of the natural environment.

Decisions or changes related to any one of the three components—human health and well-being, the environment, or the economy—have a significant impact on the other two components and, consequently, on our quality of life. Decision making must take into account all three components to ensure an equitable, reasonable, and sustainable quality of life for all.

### **Sustainable Development, Social Responsibility, and Equity**

Sustainable development supports principles of social responsibility and equity. Williams (1994) believes that the concept of equity is essential to the attainment of sustainability. This includes equity among nations, within nations, between humans and other species, as well as between present and future generations. Sustainable development is, at the same time, a decision-making process, a way of thinking, a philosophy, and an ethic. Compromise is an important idea that underlies the decision-making process within a sustainable development approach. To achieve the necessary balance among human health and well-being, the environment, and the economy, some compromises will be necessary.

There can be no greater contribution or more essential element to long-term environmental strategies leading to sustainable development that respects the environment . . . than the education of future generations in matters relating to the environment (UNESCO, 1988).

Public awareness and understanding of the concept of sustainable development and its practices are essential. If we are to change our way of life we must equip present and future generations with the knowledge and training to put sustainable development into effect (Sustainability Manitoba, 1994).

As students advance from grade to grade, they identify STSE interrelationships and apply decision-making skills in increasingly demanding contexts, as outlined in the following ways:

- **complexity of understanding**—from simple, concrete ideas to abstract ideas; from limited knowledge of science to more in-depth and broader knowledge of science and the world;
- **applications in context**—from contexts that are local and personal to those that are societal and global;
- **consideration of variables and perspectives**—from one or two that are simple to many that are complex;
- **critical judgement**—from simple right-or-wrong assessments to complex evaluations; and
- **decision making**—from decisions based on limited knowledge, made with the teacher’s guidance, to decisions based on extensive research that are made independently and involve personal judgement.

This foundation area has led to the development of the following GLOs in *Senior 4 Physics: A Foundation for Implementation*.

### **Science, Technology, Society, and the Environment (STSE) General Learning Outcomes**

As a result of their Senior Years science education, students will

- B1. describe scientific and technological developments, past and present, and appreciate their impact on individuals, societies, and the environment, both locally and globally
- B2. recognize that scientific and technological endeavours have been and continue to be influenced by human needs and the societal context of the time
- B3. identify the factors that affect health and explain the relationships among personal habits, lifestyle choices, and human health, both individual and social
- B4. demonstrate a knowledge of, and personal consideration for, a range of possible science- and technology-related interests, hobbies, and careers
- B5. identify and demonstrate actions that promote a sustainable environment, society, and economy, both locally and globally

## Scientific and Technological Skills and Attitudes

A science education that strives for developing scientific literacy must engage students in answering questions, solving problems, and making decisions. These processes are referred to as **scientific inquiry**, **technological problem solving** (the design process), and **decision making** (see Figure 4). Although the skills and attitudes involved in these processes are not unique to science, they play an important role in the development of scientific understandings and in the application of science and technology to new situations.

	<b>Scientific Inquiry</b>	<b>Technological Problem Solving (Design Process)</b>	<b>Decision Making</b>
<b>Purpose:</b> <b>Procedure:</b> <b>Product:</b>	Satisfying curiosity about events and phenomena in the natural world.  What do we know? What do we want to know?  Knowledge about events and phenomena in the natural world.	Coping with everyday life, practices, and human needs.  How can we do it? Will it work?  An effective and efficient way to accomplish a task or meet a need.	Identifying different views or perspectives based on varying information.  What are the alternatives or consequences? Which choice is best at this time?  A defensible decision in a particular circumstance.

	<b>Scientific Question</b>	<b>Technological Problem</b>	<b>STSE Issue</b>
<b>Example:</b>	Why does my coffee cool so quickly?  <i>An Answer:</i> Heat energy is transferred by conduction, convection, and radiation to the surrounding environment.	How can I keep my coffee hot?  <i>A Solution:</i> A foam cup will keep liquids warm for a long time. So will an insulated cup.	Should we use foam cups or ceramic mugs for our meetings?  <i>A Decision:</i> Since we must use disposable cups for the meeting, a biodegradable type will be chosen.

**Figure 4:** Processes for Science Education\*

\* Adapted with permission of the Minister of Education, Province of Alberta, Canada, 1999.

Each of these processes is described on the following page. Attitudes, an important element of each process, are also examined, and are treated as indicators along the pathway of student achievement. Hence, attitudes are to be modelled by teachers and students, but are not formally assessed in the same manner as other specific learning outcomes.

### **Scientific Inquiry**

Scientific inquiry is a way of learning about the universe. It involves posing questions and searching for explanations of phenomena. Although no single “scientific method” exists, students require certain skills to participate in science-related experiences using a variety of appropriate methods.

Skills such as questioning, observing, inferring, predicting, measuring, hypothesizing, classifying, designing experiments, and collecting, analyzing, and interpreting data are fundamental to scientific inquiry—as are attitudes such as curiosity, skepticism, and creativity. These skills are often represented as a cycle. This cycle involves posing questions, generating possible explanations, and collecting and analyzing evidence to determine which of these explanations is most useful and accurate in accounting for the phenomena under investigation. New questions may arise to reignite the cycle. It must be noted, however, that many scientific inquiries (past and present) do not necessarily follow a set sequence of steps, nor do they always start at the “beginning” of the cycle; scientists can be creative and responsive to scientific challenges as they arise.

### **Technological Problem Solving**

Technological problem solving seeks solutions to problems arising from human attempts to adapt to or change the environment. In Kindergarten to Grade 8 science, students have been developing these skills using a cycle of steps called the **design process**. This design process includes the proposing, creating, and testing of prototypes, products, and techniques in an attempt to reach an optimal solution to a given problem. Feedback and evaluation are built into this cycle. In Senior Years science, these technological problem-solving skills are incorporated into a decision-making process.

### **STSE Issues and Decision Making**

Students, as individuals and global citizens, are required to make decisions. Increasingly, the types of issues they face demand an ability to apply scientific and technological knowledge, processes, and products to the decisions they make related to STSE. The decision-making process involves a series of steps, which may include

- clarifying the issue;
- critically evaluating all available research;
- generating possible courses of action;
- making a thoughtful decision;
- examining the impact of the decision; and
- reflecting on the process.

Students should be actively involved in decision-making situations as they progress through their science education. Not only are decision-making situations important in their own right, but they also provide a relevant context for engaging in scientific inquiry, problem solving, and the study of STSE relationships (see Figure 5).

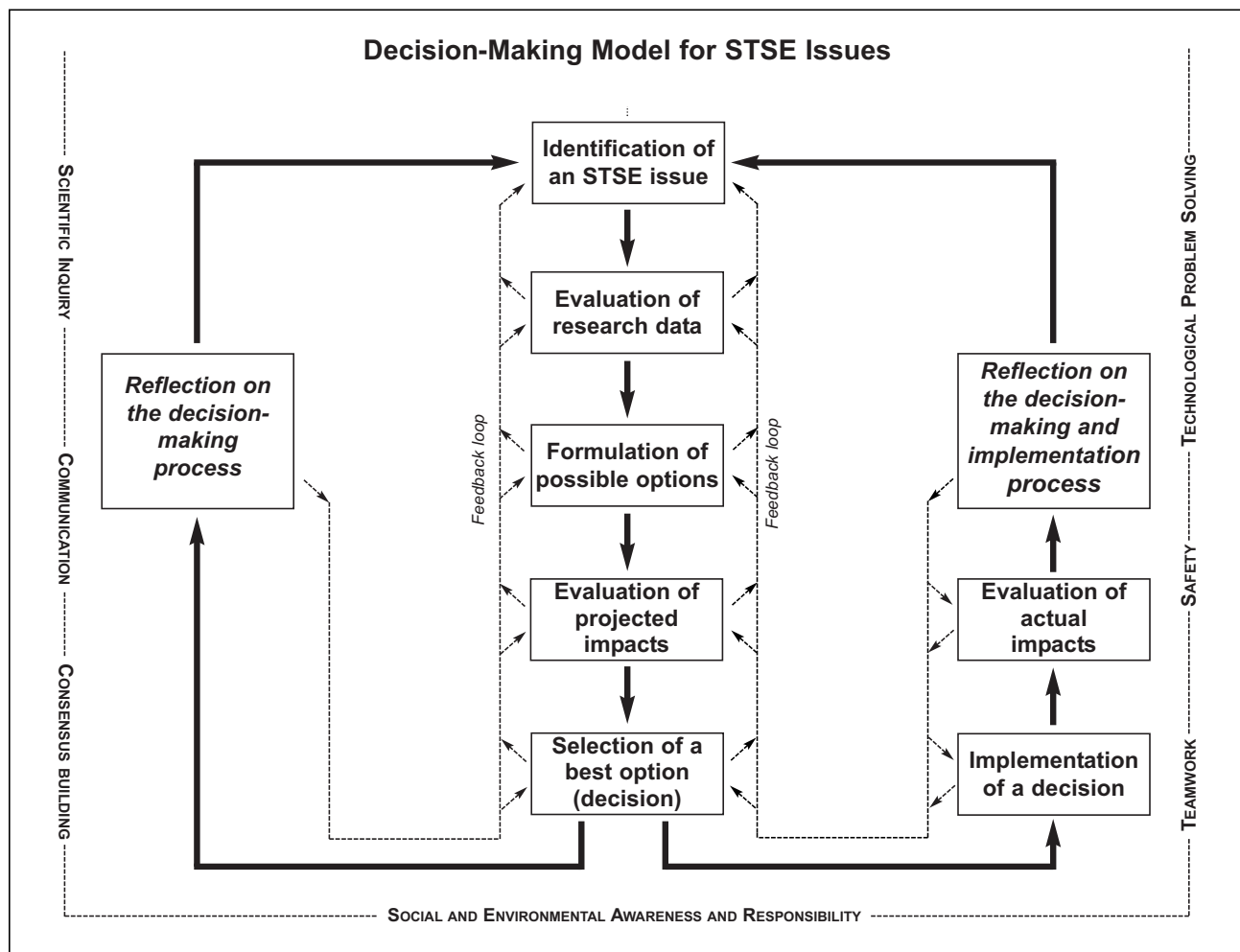

**Figure 5:** Decision-Making Model for STSE Issues

### Attitudes

Attitudes refer to generalized aspects of behaviour that are modelled for students. Attitudes are not acquired in the same way as skills and knowledge. They cannot be observed at any particular moment, but are evidenced by regular, unprompted manifestations over time. Development of attitudes is a lifelong process that involves the home, the school, the community, and society at large. The development of positive attitudes plays an important role in students' growth, affecting their intellectual development and creating a readiness for responsible application of what they learn.



The following GLOs have been developed to further define expectations related to this foundation area, and provide the basis for the set of skills and attitudes that are identified as unique to Senior 4 physics.

### **Scientific and Technological Skills and Attitudes General Learning Outcomes**

As a result of their Senior Years science education, students will

- C1. recognize safety symbols and practices related to scientific and technological activities and to their daily lives, and apply this knowledge in appropriate situations
- C2. demonstrate appropriate scientific inquiry skills when seeking answers to questions
- C3. demonstrate appropriate problem-solving skills while seeking solutions to technological challenges
- C4. demonstrate appropriate critical thinking and decision-making skills when choosing a course of action based on scientific and technological information
- C5. demonstrate curiosity, skepticism, creativity, open-mindedness, accuracy, precision, honesty, and persistence, and appreciate their importance as scientific and technological habits of mind
- C6. employ effective communication skills and utilize information technology to gather and share scientific and technological ideas and data
- C7. work co-operatively and value the ideas and contributions of others while carrying out scientific and technological activities
- C8. evaluate, from a scientific perspective, information and ideas encountered during investigations and in daily life

### **Essential Science Knowledge**

The subject matter of science includes theories, models, concepts, and principles that are essential to an understanding of life science, physical science, and Earth and space science. Content is a vehicle for essential learnings (Drake, 1993), and it will be increasingly important for students of physics to make interdisciplinary connections among the following.

**LIFE SCIENCES:** This involves the study of the growth and interactions of life forms within their environment in ways that reflect their uniqueness, diversity, genetic continuity, and changing nature. Life science includes the study of organisms (including humans and cells), ecosystems, biodiversity, biochemistry, and biotechnology.

**PHYSICAL SCIENCES:** Primarily associated with chemistry and physics, the physical sciences deal with matter, energy, and forces. Matter has structure, and interactions exist among its components. Energy links matter to gravitational, electromagnetic, and nuclear forces of the universe. The laws of conservation of mass and energy, momentum, and charge are addressed by physical science.

**GEOSCIENCES AND THE SPACE SCIENCES:** These studies provide students with local, global, and universal perspectives. Earth exhibits form, structure, and patterns of change, as does our surrounding solar system and the physical universe beyond. Earth and space science includes fields of study such as geology, hydrology, meteorology, and astronomy.

The following GLOs have been developed to further define expectations related to this foundation area.

### **Essential Science Knowledge General Learning Outcomes**

As a result of their Senior Years science education, students will

- D1. understand essential life structures and processes pertaining to a wide variety of organisms, including humans
- D2. understand various biotic and abiotic components of ecosystems, as well as their interaction and interdependence within ecosystems and within the biosphere as a whole
- D3. understand the properties and structures of matter as well as various common manifestations and applications of the actions and interactions of matter
- D4. understand how stability, motion, forces, and energy transfers and transformations play a role in a wide range of natural and constructed contexts
- D5. understand the composition of the Earth’s atmosphere, hydrosphere, and lithosphere, as well as the processes involved within and among them
- D6. understand the composition of the universe, the interactions within it, and the implications of humankind’s continued attempts to understand and explore it

### **The Unifying Concepts**

An effective way to create linkages within and among science disciplines is to use unifying concepts—the key ideas that underlie and integrate all science knowledge and extend into areas such as mathematics and social studies. Unifying concepts help students construct a more holistic, systems-related understanding of science and its role in society.

The following four unifying concepts were used in the development of *Senior 4 Physics: A Foundation for Implementation*.

#### **Similarity and Diversity**

The concepts of similarity and diversity provide tools for organizing our experiences with the world. Beginning with informal experiences, students learn to recognize attributes of materials, organisms, and events that help to make useful distinctions between and among them. Over time, students adopt accepted procedures and protocols for describing and classifying objects, organisms, and events they encounter, thus enabling them to share ideas with others and to reflect on their own experiences.

### **Systems and Interactions**

An important part of understanding and interpreting the world is the ability to think about the whole in terms of its parts and, alternately, about parts in terms of how they relate to one another and to the whole. A system is a collection of components that interact with one another so that the overall effect is often different from that of the individual parts, even when these are considered together. Students will study both natural and technological systems.

### **Change, Constancy, and Equilibrium**

The concepts of constancy and change underlie most understandings of the natural and technological world. Through observations, students learn that some characteristics of living things, materials, and systems remain constant over time, whereas others change. Through formal and informal studies, students develop an understanding of the processes and conditions in which change, constancy, and equilibrium take place.

### **Energy**

The concept of energy provides a conceptual understanding that brings together many aspects of natural phenomena, materials, and the processes of change. Energy, whether transmitted or transformed, is the driving force of both movement and change. Students learn to describe energy in terms of its effects and, over time, develop a concept of energy as something inherent within the interactions of materials, the processes of life, and the functions of systems.

The following GLOs have been developed to further define expectations related to this foundation area.

### **Unifying Concepts General Learning Outcomes**

As a result of their Senior Years science education, students will

- E1. describe and appreciate the similarity and diversity of forms, functions, and patterns within the natural and constructed world
- E2. describe and appreciate how the natural and constructed worlds are made up of systems and how interactions take place within and among these systems
- E3. recognize that characteristics of materials and systems can remain constant or change over time, and describe the conditions and processes involved
- E4. recognize that energy, whether transmitted or transformed, is the driving force of both movement and change, and is inherent within materials and in the interactions among them

## Kindergarten to Senior 3 Physics 30S Topic Chart

The following table provides a quick reference to the different thematic clusters from Kindergarten to Senior 3 Physics. This allows teachers to examine, at a glance, students' previous exposure to scientific knowledge in different areas. The physics-related content clusters are grey-shaded for reference.

	Cluster 0	Cluster 1	Cluster 2	Cluster 3	Cluster 4
Kindergarten	Overall Skills and Attitudes	Trees	Colours	Paper	---
Grade 1		Characteristics and Needs of Living Things	The Senses	Characteristics of Objects and Materials	Daily and Seasonal Changes
Grade 2		Growth and Changes in Plants	Properties of Solids, Liquids, and Gases	Position and Motion	Air and Water in the Environment
Grade 3		Growth and Changes in Plants	Materials and Structures	Forces that Attract or Repel	Soils in the Environment
Grade 4		Habitats and Communities	Light	Sound	Rocks, Minerals, and Erosion
Grade 5		Maintaining a Healthy Body	Properties of and Changes in Substances	Forces and Simple Machines	Weather
Grade 6		Diversity of Living Things	Flight	Electricity	Exploring the Solar System
Grade 7		Interactions within Ecosystems	Particle Theory of Matter	Forces and Attitudes	Earth's Crust
Grade 8		Cells and Systems	Optics	Fluids	Water Systems
Senior 1		Reproduction	Atoms and Elements	Nature of Electricity	Exploring the Universe
Senior 2		Dynamics of Ecosystems	Chemistry in Action	In Motion	Weather Dynamics
Senior 3		Waves	Nature of Light	Mechanics	Fields

**Figure 6:** Kindergarten to Senior 3 Physics 30S Topic Chart

## NOTES

---

## ***SECTION 2: IMPLEMENTATION***

The Senior Years Student and the Science Learning Environment	3
Characteristics of Senior 4 Learners	3
Effective Teaching in Physics: What the Research Says to Teachers	14
Unit Development in Physics	16
A View of Physics Education: Toward Modes of Representation	17
The Modes of Representation	18
The Importance of the Modes of Representation	21
Toward an Instructional Philosophy in Physics	23

---

---

# IMPLEMENTATION

---

## The Senior Years Student and the Science Learning Environment

Each year, teachers are called upon to make a myriad of decisions regarding course content, learning materials and resources, and instructional and assessment methods. Successful learning is more likely to occur if these decisions are informed by teachers' understanding of their students and the ways they learn.

Teachers seeking to learn about their students need to be knowledgeable in various areas, including the following:

- **How people learn:** In recent decades, cognitive psychology, brain-imaging technology, and multiple intelligences theory have transformed our understanding of learning. Ongoing professional development is important to teachers as they seek to update their knowledge of the processes of learning.
- **The ways in which student populations are changing:** The students whom teachers encounter today are different in many respects from students a generation ago. Students are more likely to be living with a single parent or stepfamily. More have part-time jobs. Students are more sophisticated in their knowledge and use of information technology, and much of their understanding of the world comes from television. Classrooms are more likely to be ethnically diverse.
- **The developmental characteristics of Senior 4 students:** The characteristics of adolescent learners have many implications for teachers.
- **The unique qualities of each student:** Family relationships, academic and life experiences, personality, interests, learning approaches, socio-economic status, and rate of development all influence a student's ability to learn. Teachers can gain an understanding of the unique qualities of each student only through daily interaction, observation, and assessment.

## Characteristics of Senior 4 Learners

For many students, Senior 4 is a stable and productive year. Many Senior 4 students have developed a degree of security within their peer group and a sense of belonging in school. They show increasing maturity in dealing with the freedoms and responsibilities of late adolescence: romantic relationships, part-time jobs, a driver's licence. In Senior 4, most students have a great deal of energy and a growing capacity for abstract and critical thinking. Many are prepared to express themselves with confidence and to take creative and intellectual risks. The stresses and preoccupations of preparing for graduation, post-secondary education, or full-time jobs are still a year away. For many students, Senior 4 may be the most profitable academic year of the Senior Years.

Although many Senior 4 students handle their new responsibilities and the demands on their time with ease, others experience difficulty. External interests may seem more important than school. Because of their increased autonomy, students who previously had problems managing their behaviour at school may now express their difficulties through poor attendance, alcohol and drug use, or other behaviours that place them at risk.

Students struggling to control their lives and circumstances may make choices that seem to teachers to be contrary to their best interests. Communication with the home and awareness of what their students are experiencing outside school continue to be important for Senior 4 teachers. Although the developmental variance evident in Grade 6 through Senior 2 has narrowed, students in Senior 4 can still change a great deal in the course of one year or even one semester. Senior 4 teachers need to be sensitive to the dynamic classroom atmosphere and recognize when shifts in interests, capabilities, and needs are occurring, so they can adjust learning experiences for their students.

The chart on the following pages identifies some common characteristics of late adolescence observed in educational studies (Glatthorn, 1993; Maxwell and Meiser, 1997; Probst, 1988) and by Manitoba teachers, and discusses the implications of these characteristics for teachers.

<b>Senior 4 Learners: Implications for Teachers</b>	
<b>Characteristics of Senior 4 Learners</b>	<b>Significance for Senior 4 Teachers</b>
<p><b>Cognitive Characteristics</b></p> <ul style="list-style-type: none"> <li>• Most Senior 4 learners are capable of abstract thought and are in the process of revising their former concrete thinking into a fuller understanding of principles.</li>   <li>• Students are less absolute in their reasoning, more able to consider diverse points of view. They recognize that knowledge may be relative to context.</li>   <li>• Many basic learning processes have become automatic by Senior 4, freeing students to concentrate on complex learning.</li>   <li>• Students have a clearer self-understanding and have developed specialized interests and expertise. They need to connect what they are learning to the world outside the school. Physics must be seen as valuable and necessary.</li> </ul>	<ul style="list-style-type: none"> <li>• Teach to the big picture. Help students forge links between what they already know and what they are learning. Be cognizant of individual differences and build bridges for students who think concretely.</li>   <li>• Focus on developing problem-solving and critical thinking skills, particularly those related to STSE and decision making.</li>   <li>• Identify the knowledge, skills, and strategies that students already possess, and build the course around new challenges. Through assessment, identify students who have not mastered learning processes at Senior 4 levels and provide additional assistance and support.</li>   <li>• Use strategies that enhance students' metacognition. Encourage students to develop scientific skills through exploring areas of interest. Cultivate classroom experts and invite students with individual interests to enrich the learning experience of the class.</li> </ul>

*(continued)*



<b>Senior 4 Learners: Implications for Teachers (continued)</b>	
<b>Characteristics of Senior 4 Learners</b>	<b>Significance for Senior 4 Teachers</b>
<p><b>Psychological and Emotional Characteristics</b></p> <ul style="list-style-type: none"> <li>• It is important for Senior 4 students to see that their autonomy and emerging independence are respected. They need a measure of control over what happens to them in school.</li>   <li>• Students are preparing for senior leadership roles within the school and may be more involved with leadership in their communities.</li>   <li>• Students need to understand the purpose and relevance of practices, policies, and processes. They may express their growing independence through a general cynicism about authority and institutions.</li>   <li>• Senior 4 students have a clearer sense of identity than they had previously and are capable of being more reflective and self-aware. Some students are more willing to express themselves and disclose their thoughts and ideas.</li> </ul>	<ul style="list-style-type: none"> <li>• Provide choice. Allow students to select many of the resources they will explore and the forms they will use to demonstrate their learning. Collaborate with students in assessment. Teach students to be independent learners. Gradually release responsibility to students.</li>   <li>• Provide students with leadership opportunities within the classroom and with a forum to practise skills in public speaking and group facilitation.</li>   <li>• Use students' tendency to question social mores to help them develop critical thinking. Negotiate policies and demonstrate a willingness to make compromises. Use students' questions to fuel classroom inquiry.</li>   <li>• Provide optional and gradual opportunities for self-disclosure. Invite students to explore and express themselves through their work. Celebrate student differences.</li> </ul>
<p><b>Physical Characteristics</b></p> <ul style="list-style-type: none"> <li>• Many Senior 4 students have reached adult physical stature. Others, particularly males, are still in a stage of extremely rapid growth and experience a changing body image and self-consciousness.</li>   <li>• By Senior 4, students are better able to sit still and concentrate on one learning task for longer periods, but they still need interaction and variety. They have a great deal of energy.</li>   <li>• Senior 4 students still need more sleep than adults, and may come to school tired as a result of part-time jobs or activity overload.</li> </ul>	<ul style="list-style-type: none"> <li>• Be sensitive to the risk students may feel in public performances and increase expectations gradually. Provide students with positive information about themselves.</li>   <li>• Put physical energy to the service of active learning instead of trying to contain it. Provide variety; change the pace frequently; use kinesthetic learning experiences.</li>   <li>• Be aware that inertia or indifference may be the result of fatigue. Work with students and families to set goals and plan activities realistically so that school work assumes a higher priority.</li> </ul>

*(continued)*

<b>Senior 4 Learners: Implications for Teachers (continued)</b>	
<b>Characteristics of Senior 4 Learners</b>	<b>Significance for Senior 4 Teachers</b>
<p><b>Moral and Ethical Characteristics</b></p> <ul style="list-style-type: none"> <li>• Senior 4 students are working at developing a personal ethic, rather than following a prescribed set of values and code of behaviour.</li>   <li>• Students are sensitive to personal or systemic injustice but are increasingly realistic about the factors affecting social change.</li>   <li>• Students are shifting from an egocentric view of the world to one centred in relationships and community. They are able to recognize different points of view and adapt to difficult situations.</li>   <li>• Students are becoming realistic about the complexities of adult responsibilities but resist arbitrary authority.</li> </ul>	<ul style="list-style-type: none"> <li>• Explore the ethical meaning of situations in life and in scientific contexts. Provide opportunities for students to reflect on their thoughts in discussion, writing, or representation.</li>   <li>• Explore ways decision-making activities can effect social change, and link to the continuum of science, technology, society, and the environment.</li>   <li>• Provide opportunities for students to make and follow through on commitments and to refine their interactive skills.</li>   <li>• Explain the purpose of every learning experience. Enlist student collaboration in developing classroom policies. Strive to be consistent.</li> </ul>
<p><b>Social Characteristics</b></p> <ul style="list-style-type: none"> <li>• By Senior 4, certain individuals will take risks in asserting an individual identity. Many students, however, continue to be intensely concerned with how peers view their appearance and behaviour. Much of their sense of self is drawn from peers, with whom they may adopt a “group consciousness” rather than making autonomous decisions.</li>   <li>• Adolescents frequently express identification with peer groups through slang, musical choices, clothing, body decoration, and behaviour.</li>   <li>• Crises of friendship and romance, and a preoccupation with relationships, can distract students from academics.</li>   <li>• Students begin to recognize teachers as individuals and welcome a personal connection.</li> </ul>	<ul style="list-style-type: none"> <li>• Ensure that the classroom has an accepting climate. Model respect for each student. Use learning experiences that foster student self-understanding and self-reflection. Challenge students to make personal judgements about situations in life and in their natural environment.</li>   <li>• Foster a classroom identity and culture. Ensure that every student is included and valued. Structure learning so that students can interact with peers, and teach strategies for effective interaction.</li>   <li>• Open doors for students to study personal relationships in science (for example, through biographies of scientists). Respect confidentiality, except where a student’s safety is at risk.</li>   <li>• Nurture and enjoy a relationship with each student. Try to find areas of common interest with each one. Respond with openness, empathy, and warmth.</li> </ul>

### Fostering a Will to Learn: Creating Links between Language and Science

Experiences of intense involvement are optimal opportunities to teach engagement in learning, and teachers should try to ensure they happen frequently in the classroom. Not every learning task, however, can be intrinsically rewarding to every learner. Being a successful learner also requires a high degree of what Corno and Randi (1997) call “sustained voluntary effort”—an attitude expressed in committing oneself to less interesting tasks, persisting in solving problems, paying conscientious attention to detail, managing time, self-monitoring, and making choices between competing values, such as the desire to do well on a homework assignment and the desire to spend the evening with friends. The willingness to make this sustained effort constitutes motivation.

Motivation is a concern of teachers, not only because it is essential to classroom learning, but also because volition and self-direction are central to lifelong learning. Science courses seek to teach students how to interpret and analyze science concepts, and to foster the desire to do so. Motivation is not a single factor that students either bring or do not bring to the classroom. It is multi-dimensional and individual, and often comprises both intrinsic and extrinsic elements. Students hold certain presuppositions about science learning that affect the way they learn. Teachers can promote certain attitudes and skills to facilitate students’ engagement in each learning task, while recognizing and affirming entry-level abilities.

In considering how they can foster motivation, teachers may explore students’ appreciation of the value (intrinsic and extrinsic) of learning experiences and their belief about their likelihood of success. Good and Brophy (1987) suggest that these two elements can be expressed as an equation; the effort students are willing to expend on a task is a product of their expectation of success and of the value they ascribe to success.

<b>Expectancy</b> (the degree to which students expect to be able to perform the tasks successfully if they apply themselves)	<b>x</b>	<b>Value</b> (the degree to which students value the rewards of performing a task successfully)	<b>=</b>	<b>Motivation</b>
--	----------	--	----------	-------------------

Teachers may, therefore, want to focus on ensuring students are able to succeed if they apply reasonable effort, and on helping students recognize the value of classroom learning experiences. The following chart provides teachers with suggestions for fostering motivation.

<b>Fostering Motivation</b>	
<b>Ways to Foster Expectations of Success</b>	<b>Best Practice and Research</b>
<ul style="list-style-type: none"> <li>• Help students to develop a sense of self-efficacy.</li> </ul>	<ul style="list-style-type: none"> <li>• Schunk and Zimmerman (1997) found that students who have a sense of self-efficacy are more willing to participate, work harder, persist longer when they encounter difficulties, and achieve at a higher level than students who doubt their learning capabilities.</li> </ul> <p>Teachers foster student self-efficacy by recognizing that each student can succeed, and communicating that belief to the student. Silver and Marshall (1990) found that a student’s perception that he or she is a poor learner is a strong predictor of poor performance, overriding natural ability and previous learning. All students benefit from knowing that the teacher believes they can succeed and will provide the necessary supports to ensure that learning takes place.</p> <p>Teachers also foster a sense of self-efficacy by teaching students that they can learn how to learn. Students who experience difficulty often view the learning process as mysterious and outside their control. They believe that others who succeed in school do so entirely because of natural, superior abilities. It is highly motivating for these students to discover that they, too, can learn and apply the strategies that successful students use when learning.</p>
<ul style="list-style-type: none"> <li>• Help students to learn about and monitor their own learning processes.</li> </ul>	<ul style="list-style-type: none"> <li>• Research shows that students with high metacognition (students who understand how they learn) learn more efficiently, are more adept at transferring what they know to other situations, and are more autonomous than students who have little awareness of how they learn. Teachers enhance metacognition by embedding, into all aspects of the curriculum, instruction in the importance of planning, monitoring, and self-assessing. Turner (1997) found that teachers foster a will to learn when they support “the cognitive curriculum with a metacognitive and motivational one” (p. 199).</li> </ul>
<ul style="list-style-type: none"> <li>• Assign tasks of appropriate difficulty, communicating assessment criteria clearly, and ensuring that students have clear instruction, modelling, and practice so they can complete the tasks successfully.</li> </ul>	<ul style="list-style-type: none"> <li>• Ellis et al. (1991) found that systemic instruction helps students learn strategies they can apply independently (see Instructional Strategies, Section 2, p. 32).</li> </ul>

*(continued)*

<b>Fostering Motivation (continued)</b>	
<b>Ways to Foster Expectations of Success</b>	<b>Best Practice and Research</b>
<ul style="list-style-type: none"> <li>• Help students to set specific and realistic personal goals and to learn from situations where they do not attain their goals, and celebrate student achievements.</li> </ul>	<ul style="list-style-type: none"> <li>• Research shows that learning is enhanced when students set goals that incorporate specific criteria and performance standards (Foster, 1996; Locke and Latham, 1990).</li> <li>• Teachers promote this by working in collaboration with students in developing assessment (see Assessment in Senior 4 Physics [Section 3], and Appendix 5).</li> </ul>
<ul style="list-style-type: none"> <li>• Offer choices.</li> </ul>	<ul style="list-style-type: none"> <li>• Intrinsic motivation is closely tied to students' self-selection of topics, texts, activities, and creative forms. Teachers may involve the students in the choice of a topic for thematic development. Support students in the search for learning resources that are developmentally appropriate and of high interest, and encourage students to bring the world views they value into the classroom. Self-selection allows students to build their learning on the foundation of their personal interests and enthusiasm.</li> </ul>
<ul style="list-style-type: none"> <li>• Set worthwhile academic objectives.</li> </ul>	<ul style="list-style-type: none"> <li>• Rather than asking students to execute isolated skills or perform exercises that are without context, embed instruction in meaningful events and activities that simulate real-world settings, and ensure that students share performances and products with a peer audience.</li> </ul>
<ul style="list-style-type: none"> <li>• Help students to learn about and monitor their own learning processes.</li> </ul>	<ul style="list-style-type: none"> <li>• In teaching specific learning strategies, focus on the usefulness of each strategy for making information meaningful, or for expressing ideas of importance to students. Emphasize the importance of science to the richness and effectiveness of students' lives, and de-emphasize external rewards and consequences such as marks.</li> </ul>
<ul style="list-style-type: none"> <li>• Ensure that scientific experiences are interactive.</li> </ul>	<ul style="list-style-type: none"> <li>• A community that encourages students to share their learning with each other values science. Teachers who model curiosity, enthusiasm, and pleasure in learning science-related concepts, and who share their experiences, foster motivation for scientific literacy.</li> </ul>

### **Creating a Stimulating Learning Environment**

A vital science class grows out of, and is reflected in, a stimulating and inviting physical environment. While the resources and physical realities of classrooms vary, a well-equipped science classroom offers or contains a variety of resources that help stimulate learning. It is helpful to involve students in the classroom design.

Ways to create a stimulating learning environment include the following:

- **FLEXIBLE SEATING ARRANGEMENTS:** Use moveable desks or tables to design seating arrangements that reflect a student-centred philosophy and that allow students to interact in various configurations.
- **A MEDIA-RICH ENVIRONMENT:** Have a classroom library of books for self-selected reading. The classroom library may include science periodicals, newspaper articles, newsletters, Internet articles, science-fiction literature, and students' published work. It may also include a binder of student reviews and recommendations, and may be decorated by student-designed posters or book jackets. Classroom reference materials could include dictionaries/encyclopedias of science, books of facts, software and CD-ROM titles, past exams collated into binders, and manuals.
- **ACCESS TO ELECTRONIC EQUIPMENT:** Provide access to a computer, television, video cassette recorder/DVD-ROM, and video camera, if possible.
- **WALL DISPLAYS:** Exhibit posters, Hall of Fame displays, murals, banners, and collages that celebrate student accomplishments. Change these regularly to reflect student interests and active involvement in the science classroom.
- **DISPLAY ITEMS AND ARTIFACTS:** Have models, plants, photographs, art reproductions, maps, newspaper and magazine clippings, fossils, musical instruments, et cetera, in your classroom to stimulate inquiry and to express the link between the science classroom and the larger world.
- **COMMUNICATION:** Post checklists, processes, and strategies to facilitate and encourage students' independent learning. Provide a bulletin board for administrative announcements and schedules.

### **Language Learning Connected to Science**

Science curricula involve all aspects of language and literacy development. Halliday suggests that as students actively use the language arts, they engage in three kinds of language learning, which can be linked to broader scientific literacy (Strickland and Strickland, 1997).

- **STUDENTS LEARN LANGUAGE:** Language learning is a social process that begins at infancy and continues throughout life. Language-rich environments enhance and accelerate the process. Terminology-rich science has a role in new language development.
- **STUDENTS LEARN THROUGH LANGUAGE:** As students listen, read, or view, they focus primarily on making meaning from the text at hand. Students use language to increase their knowledge of the world.

- **STUDENTS LEARN ABOUT LANGUAGE:** Knowledge of language and how it works is a subject in and of itself; nevertheless, science as a discipline of inquiry relies on a particular use of language for effective communication. Consequently, students also focus on language arts and its role when applied to science. Scientific literacy learning is dynamic and involves many processes. The following graphic identifies some of the dynamic processes that form the foundation for effective literacy learning in science classrooms.

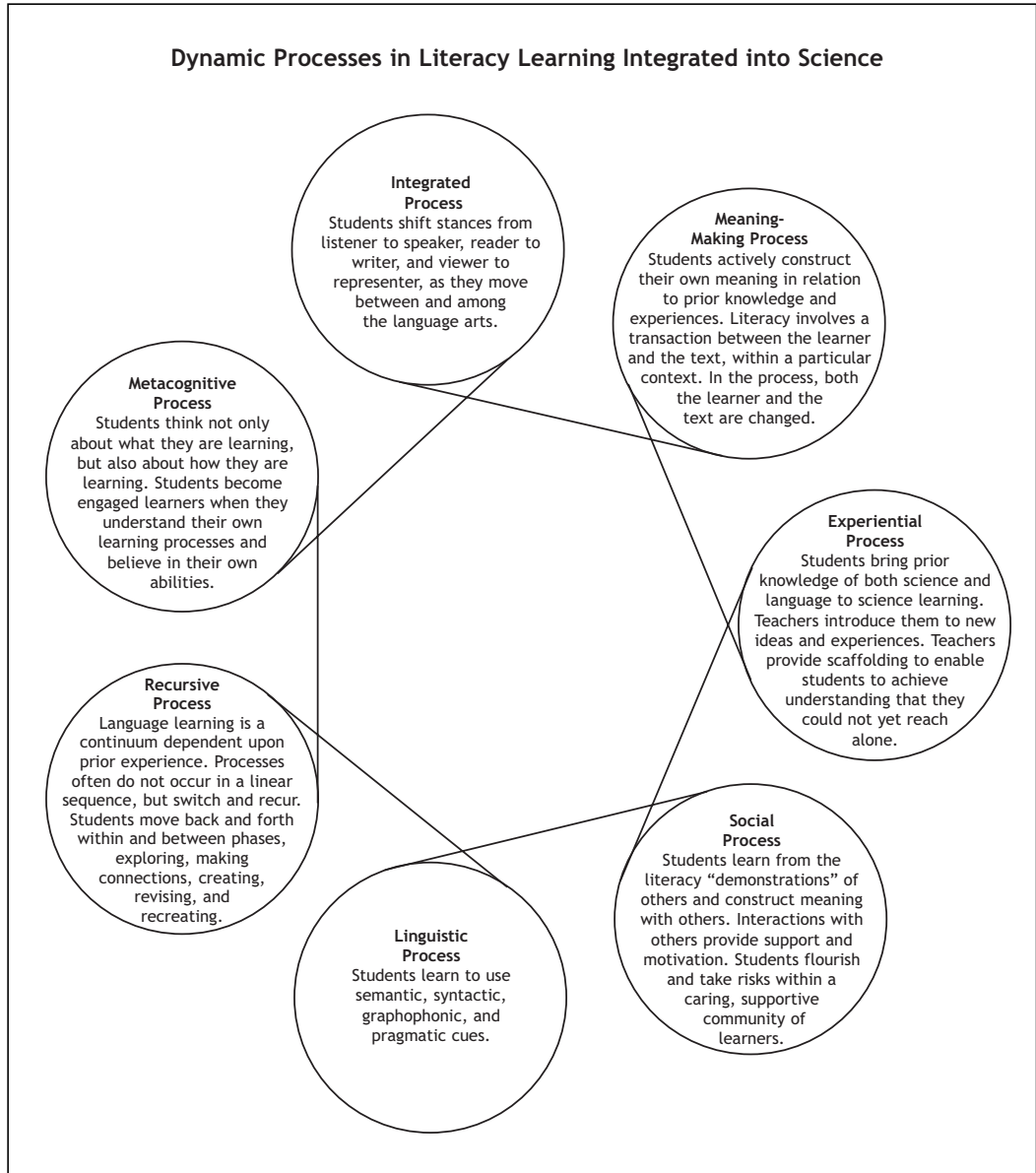

### **Ethical Issues**

The development of topics within Senior 4 Physics should lead to issues and questions that go beyond the traditional curriculum. For example, medical biophysics, or the implementation of international protocols related to the prospects of global climate change, raise questions of ethics, values, and responsible use of the products of the physical sciences. The environmental consequences of the industrial applications of chemistry, or the atmospheric physics of climate change, raise issues of considerable importance, as do the topics of nuclear waste disposal and weapons procurement. These are among the important issues that science is often called upon for advice. As students and teachers address these issues, they will naturally be drawn to the study of the underlying scientific concepts. Students should realize that science only provides the background for informed personal and social decisions, and that, as informed decision makers, they may have an impact on society and the world. Students of physics are not immune to the importance of these aspects of science in a modern, post-industrial world.

Some students and parent(s) may express concern because the perspectives of current science conflict with personal systems of belief. These individuals have a right to expect that science and the public educational system will respect those beliefs, though this does not preclude such issues arising in the classroom. Teachers should explain to students that science is one way of learning about the universe and our unique place embedded in it, and that other explanations, in addition to those of the traditional western sciences, have been put forth—particularly in the realm of cosmogony.

### **Diversity in the Classroom**

Students come from a variety of backgrounds and have distinct learning requirements, learning and thinking approaches, and prior knowledge and experiences. Their depth of prior knowledge varies, reflecting their experiences inside and outside the classroom. Some entry-level knowledge held by students may be limited or incorrect, impeding new learning. For new learning to occur, it is important for teachers to activate prior knowledge, correct misconceptions, and encourage students to relate new information to prior experiences. Manitoba's cultural diversity provides opportunities for embracing a wealth of culturally significant references and learning resources in the Senior Years science classroom. Students from various backgrounds bring socially constructed meanings, references, and values to science learning experiences, as well as their unique learning approaches. As noted in *Senior Years Science Teachers' Handbook*, "To be effective, the classroom must reflect, accommodate, and embrace the cultural diversity of its students" (Manitoba Education and Training, 1997).

In addition, cultural influences can affect how students think about science: reasoning by analogy or by strict linear logic; memorization of specific correct responses or generalization; problem solving by induction or by deduction; or needing to learn through hands-on apprenticeship to gain one aspect of a skill before moving on to the next step (Kolodny, 1991). Cultural prohibitions permeate some societies; for example, values that discourage assertiveness, outspokenness, and competitiveness in some cultures can result in behaviour that can be interpreted as being indifferent, having nothing to say, or being unable to act decisively (Hoy, 1993; NRC, 1997). The problems engendered by these cultural differences are often beyond the ability of teachers of advanced courses to handle on their own. In many such cases, support from other members of the school staff is essential.



## Learning Resources

Traditionally, the teaching of science in Senior Years has largely been a textbook-centred enterprise. The use of a single textbook as the sole resource for the teaching and learning of science severely restricts the development of knowledge, skills, and attitudes that are critical for today's students. Furthermore, it promotes the idea that all answers are enshrined in a textbook. The successful implementation of Senior 4 Physics depends on a resource-based learning approach, in which textbooks are used only as one of many reference sources. Research suggests that we should provide a wide range of learning resources for structuring teaching and learning experiences. These include human resources, textbooks, magazines/journals, films, audio and video recordings, computer-based multimedia resources, the Internet, and other materials.

Resources referenced in this curriculum include print reference material such as *Senior Years Science Teachers' Handbook: A Teaching Resource* (Manitoba Education and Training, 1997) and *Science Safety: A Kindergarten to Senior 4 Resource Manual for Teachers, Schools, and School Divisions* (Manitoba Education and Training, 1997). In addition, numerous articles from the physics education research community are recommended to teachers.

The choice of learning resources, such as text(s), multimedia learning resources (including video, software, CD-ROMs, microcomputer-based laboratory [MBL] probeware, calculator-based laboratory [CBL] probeware), and websites, will depend on the topic, the local situation, reading level of the students, background of the teacher, community resources, and availability of other materials. A concerted effort should be made to use appropriate learning resources from a wide variety of sources, as not all curricular outcomes can be achieved by using any one resource in the study of a particular topic.

To help teachers and principals select learning resources for Senior 3 and Senior 4 physics, Manitoba Education and Youth has published *Physics 30S and Physics 40S Learning Resources: Annotated Bibliography: A Reference for Selecting Learning Resources* (2003). This annotated bibliography is published online at: <<http://www.edu.gov.mb.ca/ks4/learnres/bibliographies.html>>.

## Using This Curriculum Document

Physics curricula in the past have been primarily focussed on presenting a breadth of knowledge (that is, a large amount of content) deemed essential, and with a focus on the mathematical manipulation of algorithms. While this curriculum continues to be concerned with students acquiring relevant knowledge and appropriate mathematical treatment of concepts, it is also concerned both with fostering the development of various skills (context-based process skills, decision-making skills, problem-solving skills, laboratory experimental skills, critical thinking skills, independent learning skills), and with effecting a change of viewpoint. A strong focus of Senior 4 Physics is to link science to the experiential life of the students.

By offering a multidisciplinary focus where appropriate, Senior 4 Physics provides a new set of foundations for fostering increased scientific literacy. The curriculum, consisting of 28 General Learning Outcomes (GLOs), each with a number of Specific Learning Outcomes (SLOs) linked to them, will build upon what students know and are able to do as a result of their studies in Kindergarten to Senior 3 Physics (see Figure 6: *Kindergarten to Senior 3 Physics Topic Chart*, Section 1, page 15).

Senior 4 Physics assumes **110** hours of instructional time, and is designed to include formal assessments, field excursions, and related co-curricular efforts.

## **Effective Teaching in Physics: What the Research Says to Teachers**

### **Findings of Research on How Students Learn**

Several summaries of the instructional implications of recent research on learning have been prepared. The National Research Council report *How People Learn: Brain, Mind, Experience, and School: Expanded Edition* (Bransford et al., 2000) can be adapted and elaborated specifically for the study of physics. That report leads to the following implications for effective physics instruction.

- 1. Effective teachers draw out and work with students' current understandings, including those understandings students bring with them to the course and those they develop as the course progresses.**

There is an emerging consensus in science education research, including a substantial body of work specific to introductory physics, that, to be effective, instruction must elicit, engage, and respond substantively to student understandings (Champagne, Gunstone, and Klopfer, 1985; Clement, 1983; Hake, 1998; Hestenes, Wells, and Swackhamer, 1992; McDermott and Redish, 1999). There are now a number of examples of curricula and materials designed to support interaction with students' prior understandings, and there is evidence that these approaches can achieve progress in understanding that is not possible with traditional methods for most students.

- 2. Effective teachers address students' metacognitive skills, habits, and epistemologies.**

Students need to understand not only the concepts of physics, but also the nature of knowledge and learning (Hammer, 1995; Hewson, 1985; McDermott, 1991; Reif and Larkin, 1991; White and Frederiksen, 1998). Many students arrive at physics courses, including advanced-treatment courses such as Physics AP, expecting to learn by memorizing formulas disconnected from each other, as well as from the students' experiences of the physical world. Effective instruction challenges these expectations, helping students to see physics learning as a matter of identifying, applying, and refining their current understanding. Students learn to examine assumptions hidden in their reasoning; to monitor the quality and consistency of their understanding; to formulate, implement, critique, and refine models of physical phenomena; and to make use of a spectrum of appropriate representational tools. By the end of a physics course, students develop a rich sense of the coherent, principled structure of physics and are both able and inclined to apply those principles in unfamiliar situations. In short, effective instruction should work toward the objectives identified in the *Manitoba Foundations for Science Literacy*.

**3. Effective teachers are sophisticated diagnosticians of student knowledge, reasoning, and participation.**

How teachers respond to student thinking depends critically on what they perceive in that thinking, on what they interpret to be the strengths and weaknesses of the students' understanding and approach. Effective teachers continually gather information to support this ongoing assessment from several different sources: written work on assignments, tests, and quizzes; classroom discussions; and contact with students outside the classroom. They ask students to explain their reasoning throughout their work, particularly through the appropriate and measured use of differentiated instruction techniques. Upon gaining new insights into student understanding, effective teachers adapt their instructional strategies and assessments.

**4. Effective teachers teach a smaller number of topics in greater depth, providing many examples in which the same concept is at work.**

This is a common refrain in findings from education research, often expressed in the slogan “less is more.” In part, this finding is an implication of the previous two: drawing out and working with student understandings, and addressing metacognitive skills and habits, all take time, and this necessitates a reduction in the breadth of coverage. Education research also suggests that coming to understand a concept requires multiple encounters in multiple contexts. This finding is reflected across innovations in this physics curriculum that have drawn on the “spiralling” approach fostered throughout all Kindergarten to Senior Years science in Manitoba.

**Making Interdisciplinary Connections in the Physics Classroom**

An important issue for a field as ancient as physics is how it adapts to the needs of society in a given place and time. The field of physics today faces a period of transition.

- A period in which technology and knowledge-based industries are the primary drivers of the national economy has begun.
- A period in which other areas of science, such as microbiology and genetics, will undergo rapid progress has also begun.
- The increasing availability, power, and sophistication of computational hardware and software will make possible novel quantitative descriptions of the physical universe. Society in general appears to be rapidly becoming more and more knowledge-based. Enormous quantities of information are instantly available on ubiquitous computers.

Physicists will need to be able to apply the body of knowledge developed within physics to totally new areas. In other words, physicists will be asked to become more interdisciplinary; they will have to apply their special knowledge and methods to problems that cross the boundaries of traditional disciplines.

On the other hand, the topics that possess several features that naturally allow students to begin to confront interdisciplinary issues are welcome, and align more closely to the new emphases outlined in the *Manitoba Foundations for Science Literacy*. First, there is the provision for interdisciplinary options (biomedical physics, historical physics, the nature of science as seen through physics, et cetera) that teachers may choose to create. Collaborative group work of students creates its interdisciplinary dimension through ownership of a collaborative scientific investigation. Such projects can easily involve applying knowledge

and methods from several different scientific fields. Increased interdisciplinary content could be added to physics courses by developing more contexts such as the biomedical physics unit mentioned above. Alternatively, the enriched physics course might choose to explore examples illustrating how fundamental physical principles apply to a wide variety of areas. For example, the elastic properties of DNA molecules might be used to discuss the range of validity of Hooke's law for spring forces. Biological cell membranes could be used to construct interesting examples of electrical potential differences and electric fields. In agreement with the National Research Council's *National Science Education Standards (NSES)* (1996), Manitoba Education, Citizenship and Youth encourages teachers to include some experiences with the interdisciplinary applications of physics when implementing the physics curriculum.

### Unit Development in Physics

Senior 4 Physics is driven by specific learning outcomes that can be arranged in a variety of groupings. This design empowers teachers to plan appropriate learning experiences based on the nature of their students, school, and community. Teachers are encouraged to seek their own instructional design with the new curriculum, to share approaches and experiences with colleagues, and to use it to develop and extend student experiences and understandings in new ways.

Working with bigger ideas can allow for a more in-depth inquiry. Organizing around a problem or theme will generally present information in the context of real-world applications (Willis, 1992). For instance, the treatment of vector analysis or free-body diagrams—usually taught in isolation as discrete mastery skills—could be better served by presenting these concepts at the time when the context will demand their use. Throughout the year, provide students with opportunities to uncover concepts from among the sciences in a substantial way, and to make coherent connections among them to physics.

Science deals with major themes in which people are already interested or can readily be interested: life and living things, matter, the universe, information, the 'made-world'. A primary reason, therefore, for teaching science to young people is to pass on to them some of this knowledge about the material world, simply because it is both interesting and important—and to convey the sense of excitement that scientific knowledge brings (Millar and Osborne, 1998).

For teachers adopting a “thematic” or “big ideas from physics” approach to organizing the course, choosing an effective theme is critical to the success of such a pathway. Involving students in the selection of a theme (or the important subcomponents of a compulsory topic) will encourage and motivate them by recognizing their interests.

A theme should

- be broad enough for students to find personal areas of interest;
- promote learning;
- have substance and apply to the real world;
- have relevant materials readily available;
- be meaningful and age-appropriate;
- have depth;
- integrate across the disciplines of physics, biology, chemistry, and geo sciences; and
- fascinate students (Willis, 1992).

### **A View of Physics Education: Toward Modes of Representation**

Ask your students to respond, in one sentence, to the question “What is physics?” Responses tend to describe previous experiences with physics content: “physics is motion” or “physics is the study of energy and matter.” Other responses are more global: “physics is the study of the universe” or “physics is the science of all things.” The relationship of mathematics to physics is predominant; a common lament is “physics is math” or “physics is figuring out the simple things in everyday life in a mathematically complex way.” These responses indicate that students see mathematics as *the* process of physics. Many see physics as an important aspect of their preparation for an uncertain future, but with a varying sense of what physics really is and what it could do for them.

What is physics? Although answers vary, if you consider the various branches of physics and the underlying principles, a common theme exists. Physics is the study of relationships in the world we perceive around us. However, those relationships are embedded in a social and historical context—a set of lenses through which the relationships are perceived and acted upon. For instance, we contemplate “something interesting,” then build models to identify fundamental characteristics to determine how they interact and influence each other. From these relationships we are able to predict the behaviour of other “interesting things” that have the same or similar parameters. A major component of physics, then, is the study of relationships in a variety of different forms. What makes the study of physics so difficult for so many is that relationships can be represented in many different ways—and too often in just one manifestation, the mathematical symbolic relationship. To facilitate teaching and learning, it is important to understand these modes of representation and their relationship to each other.

## The Modes of Representation

### The Visual Mode

To illustrate these modes of representation, consider an example. A 0.5-kg mass is suspended from a spring (Diagram 1). If we suspend a 1.0-kg mass and a 1.5-kg mass from identical springs, we perceive the relationship between the force that acts on the spring and the stretch of the spring. This is what we would call the visual mode of representing a relationship. Its basis is in the “real” world and our perceptions of this world.

In the visual mode we formulate a relationship between two variables and then test our hypothesis by observation and experimentation. As the force increases, the stretch increases. Sometimes, we can even determine the exact relationship. In this case, since the masses in Diagram 1 line up in a straight line, the applied force and stretch must increase in some predictable proportion.

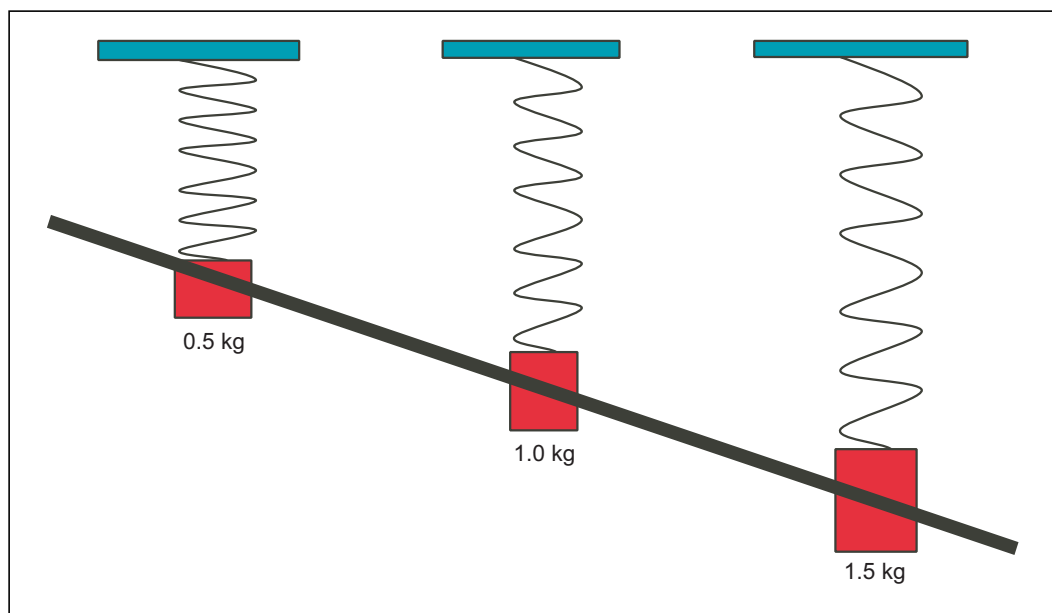
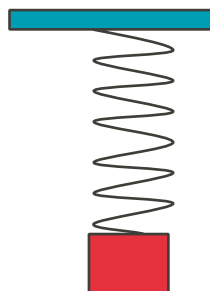

**Diagram 1**

The visual mode embodies more than conjecture and observation. It incorporates critical and creative thinking as we build and modify models of nature that act as a foundation for our investigations. The “real” world is conceptualized by a set of guiding assumptions we imagine to be true. We may internalize a model to aid this conceptualization, and then we test this model using experiments. A successful model has explanatory and predictive capabilities. A model may incur discrepant events, which may force us to reconsider and modify our model. Our model may be falsified, in which case we abandon the model in search of a more complete and accurate model. For instance, the model of electric charge provides a foundation for the examination of electric phenomena. Historically, the fluid and particle models of charge accounted for experimental observations. However, as our ideas about the structure of matter evolved, the particle model provided a more reliable, predictive, and robust explanatory model.

Although we can make some general descriptions of relationships (as force increases, stretch increases), we can not always determine an exact relationship using the visual mode of representation. Therefore, we quantify the characteristics and compare the numbers. This is called the **numerical** mode of representation.

### Numerical Mode

In the numerical mode of representation, we operationally define fundamental properties and use measurement to collect data. We can then examine the data to determine an exact relationship. The numerical mode dictates an understanding of proportioning and numerical patterns (e.g., if  $F$  doubles,  $X$  doubles, and if  $F$  triples,  $X$  triples). This suggests a direct proportion, and we can formulate our law. However, in most cases, the collection of data results in systematic errors. Determining the relation by inspection of the data can be very difficult. A picture, however, is worth a thousand numbers. Graphing the data usually gives a clearer picture of the relationship. It could be looked upon, for students, as a preparation for examining closely a “picture of the numbers.”

$F$ (N)	$X$ (m)
5.0	0.2
10.0	0.4
15.0	0.6
20.0	0.8

### Graphical Mode

The **graphical** mode of representation is a mathematical picture of the relationship. Fortunately, there are a limited number of pictures one needs to know to determine relationships. In fact, at the introductory Senior 4 Physics level, it is only necessary to know three pictures: a straight line, a power curve, and an inverse curve. By adjusting the data to “straighten the curve,” we can determine the exact relationship and formulate a law that can be represented in a symbolic manner.

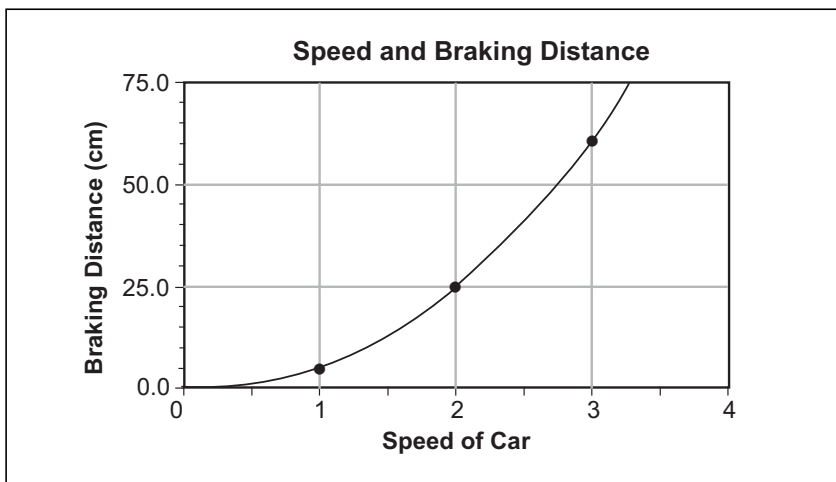
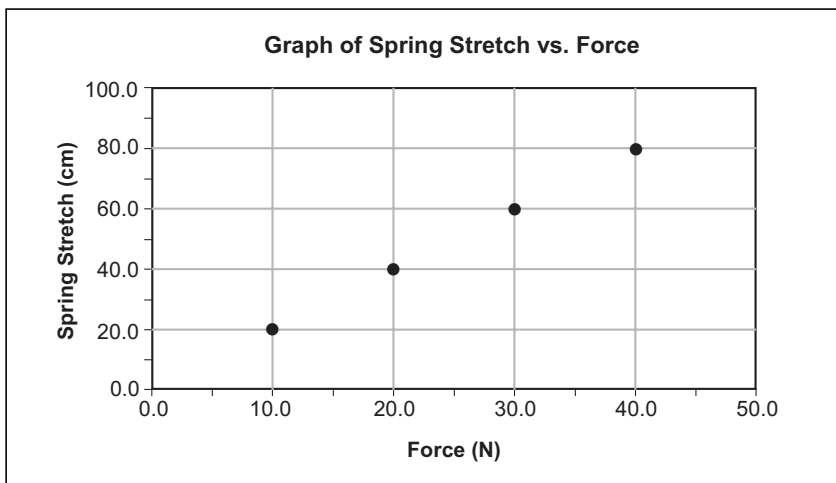



### Symbolic Mode

The fourth mode of representation is the **symbolic** mode. We represent the relationship as an algebraic formula, which can be applied to other physical events that are similar in nature.

For instance,

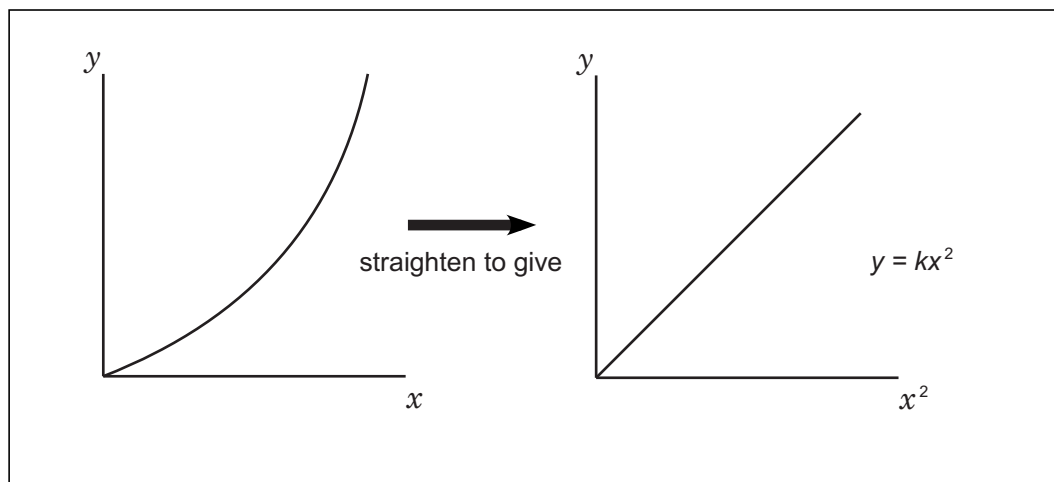

Therefore, we can represent relationships in four different modes: visual, numerical, graphical, and symbolic. In our model of physics education, students are able to function in each mode to demonstrate complete understanding and mastery of the concepts.

### The Importance of the Modes of Representation

It is easy to become caught up in a single mode, especially the symbolic, when it comes to the teaching and learning of physics. Students often complain about the number of formulas in their physics course, or even question their purpose. They dutifully memorize equations and notation, learn to substitute for variables, and arrive at numeric solutions. Students and teachers can easily become trapped exclusively within the symbolic mode of representation. Instruction using the symbolic mode risks neglecting other important modes of representation that are precursors to the symbolic. The teacher, already grounded in mathematical principles, only must derive an equation algebraically. This “out of context” treatment of relationships between the physical/conceptual (i.e., visual mode variables) and the symbolic presents tremendous difficulties for most students, including those students who are apparently mathematically competent.

Meaningful connections between the symbolic and physical/conceptual modes are difficult to make in a decontextual setting. Many teachers’ own instruction in physics was primarily in the symbolic mode, and they may not have mediated concepts using alternative modes. Students taught exclusively in the symbolic mode often know how to arrive at “cookbook” answers, but they rarely understand the physics or retain any of the concepts. In fact, their difficulties rarely focus on physics. Confusion appears because of notation, similar types of equations, various algebraic representations of formulas, and calculations. As soon as physical concepts are necessary, such as in word problems beyond the “plug and slug” variety, success rates decrease dramatically. Research in physics education, such as Hestenes’ et al. (1992) “Force Concept Inventory” and McDermott and Schaffer’s (1992)

circuit tests, indicates that even advanced students cannot operate in the physical/conceptual domain. This, of course, may not be surprising if their instruction has been almost exclusively in the symbolic mode of representation.

Students need to develop their understanding of relationships more completely and develop skills in each mode of representation. Students should be able to transfer between modes both fluidly and with facility. Moving through the modes is not necessarily done in order. A “real scientist” can begin investigations in any mode and transfer easily through any combination of modes. Students who demonstrate a complete understanding of physical/conceptual relationships should be able to move from mode to mode in any order.

While fluency with the modes of representation provides a solid foundation for physics education, it is, of itself, not complete when it comes to portraying the nature of scientific activity. Albert Einstein, while developing his theory of relativity, conceptualized an hypothesis and then deduced a series of laws symbolically from a set of fundamental assumptions about time and space. He left it to others to observe, then refute or confirm his propositions. Historical perspectives, and an understanding of the nature of science, will move students toward a more philosophically valid treatment of physics.

**To Sum Up the Modes of Representation for Physics Teachers**

**Visual:** encourage students to discuss the representations they see and experience

**Numeric:** use student-generated measurements; always in the context of activities

**Graphical:** carefully plot graphs; get the "picture of the numbers," not "this is a picture of the world"

**Symbolic:** emphasize the concept first, then initially apply formulas as word definitions; only then work "type" problems using formulas; ideally, formulas are memorized only in certain instances

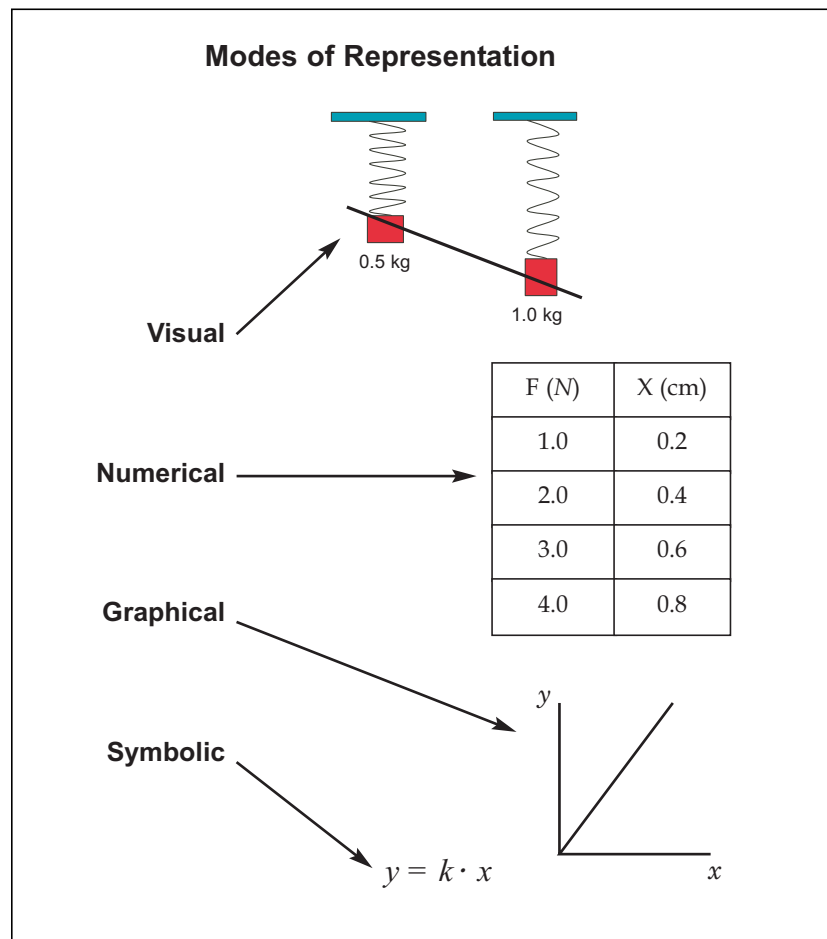

## **Toward an Instructional Philosophy in Physics**

Teaching Senior 4 Physics with a focus on both content and processes should naturally allow for the use of a variety of instructional strategies. These strategies include the collection and analysis of data from both laboratory and fieldwork, group and individual instruction, a diversity of questioning techniques, decision making, problem solving, design process activities, and a resource-based approach to learning. Senior Years science programming should foster critical thinking skills and promote the integration of knowledge and application of facts to real-life situations. Scientific concepts from other Senior Years science courses may become part of the subject matter as the Senior 4 Physics course develops in the classroom. This is a valuable and useful means of reinforcing and validating those concepts as having relevant and contextual applications.

In general, physics is, in part, a way of thinking that has rules for judging the validity of answers applicable to everyday life. It can be portrayed as intense human activity, full of trial and error, that is influenced by cultural priorities and humanistic perspectives. The myth of total objectivity that often permeates scientific dialogue also should be exposed and discussed. Among the natural sciences, “scientific truth” is no longer viewed as an objective reality awaiting discovery; rather, it is placed in the context of something always to be sought. In recognition of the tentative nature of current knowledge claims, “scientific truth” is not a goal that can be reached in absolute terms, but can remain as one of the hallmarks of the traditions of scientific practice.

Encourage students to make distinctions between what is observable and testable, as well as the abstract deductions, models, and themes that derive from evolving scientific research and thinking.

Conceptual knowledge in science can also be integrated with principles from other disciplines. Social, historical, and political implications, if included, provide an opportunity for students to develop a facility to communicate ideas effectively through verbal and written expression. Finally, students could be provided with an opportunity to develop an awareness of the options available to them for careers and vocations in the wide diversity of sciences.

Senior 4 Physics, as a component of young people’s whole educational experience, will assist in preparing them for a full and satisfying life in the 21st century. This course will sustain and develop the curiosity of young people about the natural world around them, and build up their confidence in their ability to inquire into its behaviour, now and in the future. It seeks to foster a sense of wonder, enthusiasm, and interest in science so that young people feel confident and competent to engage with everyday scientific and technological applications and solutions. As students study a range of topics through various subdisciplines of physics, they will acquire a broad, general understanding of the important ideas and explanatory frameworks of the field as a whole, including the procedures of scientific inquiry that have had a major impact on our material environment and on our culture. They will develop an appreciation for why these ideas are valued and the underlying rationale for decisions that they may wish, or be advised, to take in everyday contexts, both now and in later life. They will be able to understand, and respond critically to, media reports of issues with a science (particularly a physics-related) component. They will feel empowered to hold and express a personal point of view on issues with a science component that enter the arena of public debate, and perhaps to become actively involved in some of these issues (Millar and Osborne, 1998, p. 12).

### Results-Based Learning

In results-based learning, the programming focus is on what students know and can do, rather than on what material is “covered.” The learning outcomes are an elaboration of the knowledge, strategies, and skills and attitudes expected of each Senior 4 Physics student. All programming decisions are directed toward addressing the gap between the students’ present level of performance and the performance specified in the learning outcomes.

Bridging the Gap between Student Performance and the Prescribed Learning Outcomes		
Present Level of Student Performance	Programming Decisions	Senior 4 Student Learning Outcomes
<ul style="list-style-type: none"> <li>• Instructional Strategies</li> <li>• Materials and Resources</li> <li>• Assessment Tools and Strategies</li> </ul>		

The student learning outcomes are not taught separately or in isolation. Nor are they taught consecutively in the order in which they appear in the curriculum documents. Most lessons or units draw on knowledge, strategies, and skills and attitudes addressed in several or all general learning outcomes. In the process of planning, teachers are encouraged to identify the learning outcomes they intend to assess, and link all assessment to the specific learning outcomes.

In implementing results-based curricula, experienced teachers may find that they use many of the instructional strategies and resources they have used previously. However, the nature of results-based learning will reshape their programming in several ways:

- Planning is ongoing throughout the semester or year because instruction is informed by learning requirements that become evident through continuous assessment.
- Some learning outcomes, especially skills and attitudes outcomes, are addressed repeatedly in different ways throughout the school semester or year. As students develop new scientific knowledge, strategies, and skills and attitudes, they need to practise and refine those they have previously experienced.

### Varied Instructional Approaches

Teachers wear a number of different “pedagogical hats,” and change their teaching style relative to the cognitive gains, attitudes, and skills demanded of the task at hand. In planning instruction for Senior 4 Physics, teachers may draw upon a repertoire of instructional approaches and methods and use combinations of these in each unit and lesson. Many suggestions are contained in this document.

Instructional approaches may be categorized as

- direct instruction;
- indirect instruction;
- experiential learning;
- independent study; and
- interactive instruction.

Most teachers draw from all these categories to ensure variety in their classroom learning experiences, to engage students with various intelligences and a range of learning approaches, and to achieve instructional goals.

The following diagram displays instructional approaches and suggests some examples of methods within each approach. Note that the approaches overlap.

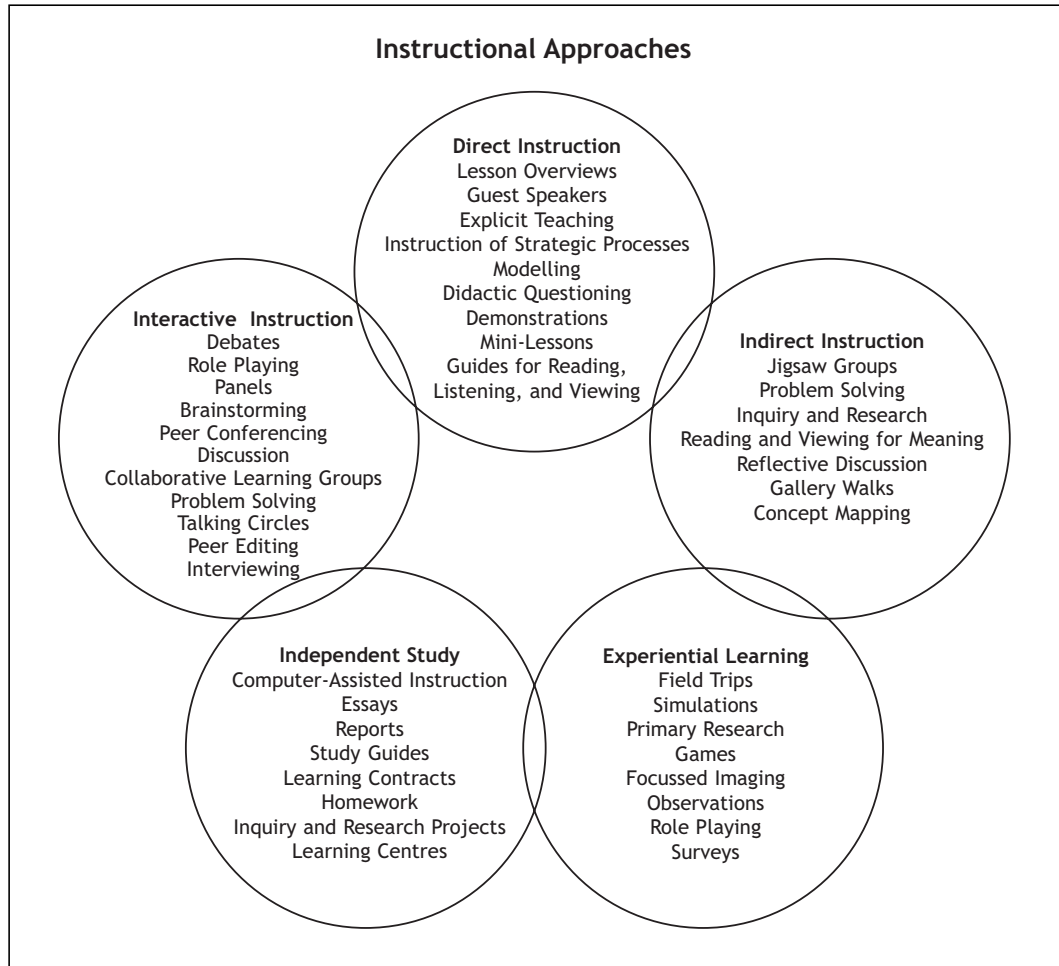

Adapted from *Instructional Approaches: A Framework for Professional Practice*. Copyright © 1991 Saskatchewan Education. Reprinted by permission. All rights reserved.

### Solving Instructional Approaches

In selecting instructional approaches and methods, teachers consider which combination will assist students in achieving the learning outcomes targeted for a particular lesson or unit. Teachers consider the advantages and limitations of the approaches and methods, as well as the interests, knowledge, and skills and attitudes of their students. Some of these elements are represented in the following chart.

<b>Instructional Approaches: Roles, Purposes, and Methods</b>				
<b>Instructional Approaches</b>	<b>Roles</b>	<b>Purposes/Uses</b>	<b>Methods</b>	<b>Advantages/ Limitations</b>
<b>Direct Instruction</b>	<ul style="list-style-type: none"> <li>Highly teacher-directed</li> <li>Teacher ensures a degree of student involvement through didactic questioning</li> </ul>	<ul style="list-style-type: none"> <li>Providing information</li> <li>Developing step-by-step skills and strategies</li> <li>Introducing other approaches and methods</li> <li>Teaching active listening and note making</li> </ul>	Teachers: <ul style="list-style-type: none"> <li>Explicit teaching</li> <li>Lesson overviews</li> <li>Guest speakers</li> <li>Instruction of strategic processes</li> <li>Lecturing</li> <li>Didactic questioning</li> <li>Demonstrating and modelling prior to guided practice</li> <li>Mini-lessons</li> <li>Guides for reading, listening, and viewing</li> </ul>	<ul style="list-style-type: none"> <li>Effective in providing students with knowledge of steps of highly sequenced skills and strategies</li> <li>Limited use in developing abilities, processes, and attitudes for critical thinking and interpersonal learning</li> <li>Students may be passive rather than active learners</li> </ul>
<b>Indirect Instruction</b>	<ul style="list-style-type: none"> <li>Mainly student-centred</li> <li>Role of teacher shifts to facilitator, supporter, resource person</li> <li>Teacher monitors progress to determine when intervention or another approach is required</li> </ul>	<ul style="list-style-type: none"> <li>Activating student interest and curiosity</li> <li>Developing creativity and interpersonal skills and strategies</li> <li>Exploring diverse possibilities</li> <li>Forming hypotheses and developing concepts</li> <li>Solving problems</li> <li>Drawing inferences</li> </ul>	Students: <ul style="list-style-type: none"> <li>Observing</li> <li>Investigating</li> <li>Inquiring and researching</li> <li>Jigsaw groups</li> <li>Problem solving</li> <li>Reading and viewing for meaning</li> <li>Reflective discussion</li> <li>Concept mapping</li> </ul>	<ul style="list-style-type: none"> <li>Students learn effectively from active involvement</li> <li>Allows for high degree of differentiation and pursuit of individual interests</li> <li>Teacher requires excellent facilitation and organizational skills</li> <li>Focussed instruction of content and concepts may be difficult to integrate</li> </ul>

(continued)

<b>Instructional Approaches: Roles, Purposes, and Methods (continued)</b>				
<b>Instructional Approaches</b>	<b>Roles</b>	<b>Purposes/Uses</b>	<b>Methods</b>	<b>Advantages/ Limitations</b>
<b>Interactive Instruction</b>	<ul style="list-style-type: none"> <li>• Student-centred</li> <li>• Teacher forms groups, teaches and guides small-group skills and strategies</li> </ul>	<ul style="list-style-type: none"> <li>• Activating student interest and curiosity</li> <li>• Developing creativity and interpersonal skills and strategies</li> <li>• Exploring diverse possibilities</li> <li>• Forming hypotheses and developing concepts</li> <li>• Solving problems</li> <li>• Drawing inferences</li> </ul>	Students participating in: <ul style="list-style-type: none"> <li>• Discussions</li> <li>• Sharing</li> <li>• Generating alternative ways of thinking and feeling</li> <li>• Decision making</li> <li>• Debates</li> <li>• Role playing</li> <li>• Panels</li> <li>• Brainstorming</li> <li>• Peer conferencing</li> <li>• Collaborative learning groups</li> <li>• Problem solving</li> <li>• Talking circles</li> <li>• Interviewing</li> <li>• Peer editing</li> </ul>	<ul style="list-style-type: none"> <li>• Student motivation and learning increase through active involvement in groups</li> <li>• Teacher’s knowledge and skill in forming groups, instructing, and guiding group dynamics are important to the success of this approach</li> <li>• Effective in assisting students’ development of life skills in co-operation and collaboration</li> </ul>
<b>Experiential Instruction</b>	<ul style="list-style-type: none"> <li>• Student-centred</li> <li>• Teacher may wish to design the order and steps of the process</li> </ul>	<ul style="list-style-type: none"> <li>• Focussing on processes of learning rather than products</li> <li>• Developing students’ knowledge and experience</li> <li>• Preparing students for direct instruction</li> </ul>	Students participating in: <ul style="list-style-type: none"> <li>• Activities</li> <li>• Field trips</li> <li>• Simulations</li> <li>• Primary research</li> <li>• Games</li> <li>• Focussed imaging</li> <li>• Role playing</li> <li>• Surveys</li> <li>• Sharing observations and reflections</li> <li>• Reflecting critically on experiences</li> <li>• Developing hypotheses and generalizations in new situations</li> </ul>	<ul style="list-style-type: none"> <li>• Student understanding and retention increase</li> <li>• Hands-on learning may require additional resources and time</li> </ul>
<b>Independent Study</b>	<ul style="list-style-type: none"> <li>• Student-centred</li> <li>• Teacher guides or supervises students’ independent study; teaches knowledge, skills, and strategies that students require for independent learning; and provides adequate practice</li> </ul>	<ul style="list-style-type: none"> <li>• Accessing and developing student initiative</li> <li>• Developing student responsibility</li> <li>• Developing self-reliance and independence</li> </ul>	Students participating in: <ul style="list-style-type: none"> <li>• Inquiry and research projects</li> <li>• Using a variety of approaches and methods</li> <li>• Computer-assisted instruction</li> <li>• Essays and reports</li> <li>• Study guides</li> <li>• Learning contracts</li> <li>• Homework</li> <li>• Learning centres</li> </ul>	<ul style="list-style-type: none"> <li>• Students grow as independent, lifelong learners</li> <li>• Student maturity, knowledge, skills and strategies are important to success</li> <li>• Student access to resources is essential</li> <li>• Approach may be used flexibly (it may be used with individual students while other students use other approaches)</li> </ul>



### **Phases of Learning**

When preparing instructional plans and goals, many teachers find it helpful to consider three learning phases:

- activating (preparing for learning);
- acquiring (integrating and processing learning); and
- applying (consolidating learning).

These phases are not entirely linear but are a useful way of thinking and planning. A variety of activating, acquiring, and applying strategies are discussed in *Success for All Learners: A Handbook on Differentiating Instruction* (Manitoba Education and Training, 1996).

#### ***Activating (Preparing for Learning)***

One of the strongest indications of how well students will comprehend new information is their prior knowledge of the subject. Some educators observe that more student learning occurs during this phase than at any other time. In planning instruction and assessment, teachers develop student learning experiences and select strategies for activating their students' prior knowledge. Using these activating strategies, the learning experiences then provide information about the extent of students' prior knowledge of the topic to be studied, their knowledge of and familiarity with the context in which that knowledge was acquired, and their knowledge of and proficiency in applying skills for learning.

Learning experiences that draw on students' prior knowledge

- help students relate new information, skills, and strategies to what they already know and can do (e.g., if a text includes unfamiliar vocabulary, students may not recognize the connection between what they know and the new material being presented);
- allow teachers to recognize misconceptions that might make learning difficult for students;
- allow teachers to augment and strengthen students' knowledge base when students do not possess adequate prior knowledge and experience to engage with new information and ideas;
- help students recognize gaps in their knowledge; and
- stimulate curiosity and initiate the inquiry process that will direct learning.

#### ***Acquiring (Integrating and Processing Learning)***

In the second phase of learning, students engage with new information and integrate it with what they already know, adding to and revising their previous knowledge. Part of the teacher's role in this phase is to present this new information or to help students access it from various resources.

Since learning is an internal process, however, facilitating learning requires more of teachers than simply presenting information. In the acquiring phase, teachers instruct students in strategies that help them make meaning of information, integrate it with what they already know, and express their new understanding. In addition, teachers monitor these processes to ensure that learning is taking place, using a variety of instruments, tools, and strategies such as observations, conferences, and examination of student work.

In practice, within an actual lesson or unit, the acquiring phase of learning may include a series of steps and strategies, such as

- setting the purpose (e.g., discrepant events, lesson overviews, learning logs, admit slips);
- presenting information (e.g., lab demonstrations, guest speakers, mini-lessons, active reading);
- processing information (e.g., note making, group discussions, journals, visual representations);
- modelling (e.g., role playing, demonstrations); and
- checking for understanding (e.g., quizzes, informal conferences).

### ***Applying (Consolidating Learning)***

New learning that is not reinforced is soon forgotten. The products and performances by which students demonstrate new learning are not simply required for assessment; they have an essential instructional purpose in providing students with opportunities to demonstrate and consolidate their new knowledge, skills and strategies, and attitudes. Students also need opportunities to reflect on what they have learned and to consider how new learning applies to new situations. By restructuring information, expressing new ideas in another form, or integrating what they have learned in science with concepts from other subject areas, students strengthen and extend learning.

To ensure that students consolidate new learning, teachers plan various learning experiences involving

- reflection (e.g., journals, exit slips);
- closure (e.g., sharing of products, debriefing on processes); and
- application (e.g., inquiry, design process).

### **Differentiating Instruction**

How can Senior Years science teachers meet each student's learning requirements and still make learning experiences challenging and meaningful for all? One way to help all students achieve the prescribed student learning outcomes is to differentiate the instructional strategies. Senior 4 Physics makes reference to a variety of field-validated strategies for differentiating instruction. Most have been taken from the support document *Senior Years Science Teachers' Handbook* (Manitoba Education and Training, 1997).

Through differentiating instruction, teachers can

- activate students' prior knowledge;
- accommodate multiple intelligences and the variety of learning and thinking approaches;
- help students interpret, apply, and integrate information;
- facilitate the transfer of knowledge, skills, and attitudes to students' daily lives; and
- challenge students to realize academic and personal progress and achievement.

Differentiating instruction does not mean offering different programming to each student. Classroom experiences can be differentiated by offering students choices and by varying instructional and assessment strategies to provide challenging and effective learning experiences for all.

**Promoting Strategic Learning**

Many of the tasks science students perform are problem-solving tasks, such as finding sources of information for an inquiry project, making meaning of a difficult text, or organizing a body of information. To solve problems, students require a strategic mindset; when confronted with a problem, students survey a number of possible strategies, select the one that seems likely to work best for the situation, and try an alternative method if the first one does not produce results.

Strategic learners in the sciences need to have not only a strategic mindset, but also a repertoire of strategies for making meaning, for processing information, and for expressing ideas and information effectively. Whereas skills are largely unconscious mental processes that learners use in accomplishing learning tasks, strategies are systematic and conscious plans, actions, and thoughts that learners select or invent and adapt to each task. Strategies are often described as “knowing what to do, how to do it, when to do it, and why it is useful.”

**Scaffolding: Supporting Students in Strategic Learning**

Many scientific tasks involve a complex interaction of skills. The most effective way to learn, however, is not by breaking down the tasks into manageable parts and teaching the skills separately and in isolation. In fact, this approach may be counterproductive. Purcell-Gates (1996) uses the analogy of learning to ride a bicycle, a skill that requires children to develop an intuitive sense of balance while also learning to pedal and steer. Children do not learn to ride a bicycle by focussing on only one of these skills at a time. Instead, they observe others who can ride a bicycle successfully, and then make an attempt themselves. In the early stages of learning to ride, a child counts on someone to provide support—to hold the bicycle upright while the child mounts, to keep a hand on the seat to stabilize the bicycle for the first few metres, and to coach and encourage. Gradually, these supports are withdrawn as the rider becomes more competent. Eventually, the process becomes automatic, and the rider is no longer aware of the skills being performed.

Providing this sort of support in teaching is called “scaffolding,” based on the work of Wood, Bruner, and Ross (1976). Teachers scaffold by

- structuring tasks so that learners begin with something they can do;
- reducing the complexity of tasks;
- calling students’ attention to critical features of the tasks;
- modelling steps; and
- providing sufficient guided and independent practice.

In a sense, each learning strategy is an external support or scaffold. At first, working with a new strategy may be challenging and the main focus of students’ attention. Eventually, students use the strategy automatically and rely on it as a learning tool. Students gradually internalize the process of the strategy. They begin to adjust and personalize the process and to apply the thinking behind the strategy automatically.

In strategic instruction, teachers observe and monitor students' use of a strategy for a time, intervening where necessary. Students vary in the length of time they require scaffolding. In this respect, strategic instruction is also a useful tool for differentiation. Struggling learners may work with simplified versions of a strategy, and they may continue to use the supports of a strategy (for example, a graphic organizer for laboratory reports) after other students have internalized the process.

Strategic instruction works best when teachers pace the instruction of new strategies carefully (so that students have time to practise each one), and when they teach a strategy in the context of a specific task of relevant scientific experience.

### **Instructional Strategies**

The following outlines instructional strategies that may be used with Senior 4 Physics. The strategies are referenced in the Suggestions for Instruction columns of this document.

- **Journal Writing**

- Science journal writing allows students to explore and record various aspects of their experiences in science class. By sorting out their thoughts on paper or thinking about their learning (metacognition), students are better able to process what they are learning.

- **Class Discussion**

- Discussions may be used in a variety of ways. They may spark interest in a topic or learning outcome, activate prior knowledge by inviting speculation on why certain events occur, or generate ideas for solutions to problems.

- **Prior Knowledge Activities**

- Students learn best when they are able to relate new knowledge to what they already know. Brainstorming, KWL charts, and Listen-Think-Pair-Share (see *Senior Years Science Teachers' Handbook*) are just a few of the strategies that may be used to activate and assess students' prior knowledge.

- **Student Research/Reports**

- Learning projects that involve student research are one of the most effective ways to individualize instruction in a diverse classroom. These learning activities provide students with the opportunity to develop their research skills as they gather, process, and evaluate information.

- **Teacher/Student Demonstration**

- Demonstrations, such as discrepant events, may be used to arouse student interest and allow for visualization of phenomena. Demonstrations can activate prior knowledge and generate discussion about learning outcomes.

- **Visual Displays**

- When students create visual displays, they make their thinking visible. Generating diagrams, posters, or models provides students with the opportunity to represent abstract information in a more concrete form.

- **Collaborative Teamwork**
  - Instructional strategies, such as the Jigsaw or Roundtable (see *Senior Years Science Teachers' Handbook*), encourage students to learn from one another and to develop teamwork skills. The use of cooperative learning activities may lead to increased understanding of content and improved thinking skills.
- **Laboratory Activities**
  - Laboratory activities, whether student- or teacher-designed, provide students with the opportunity to apply their scientific knowledge and skills related to a group of learning outcomes. Students appreciate the hands-on experience of doing science.
- **Debates**
  - Debates draw upon students' own positions on STSE issues. When carefully structured, debates may be used to encourage students' consideration of societal concerns and the opinions of others, and to improve their communication and research skills.
- **Community Connection**
  - Field trips and guest speakers may provide students with the opportunity to see science applied in their community and local natural environments.
- **Web Quests**
  - A Web Quest is an inquiry-oriented activity in which most or all the information used by learners comes from resources on the Internet. Web Quests are designed to use learners' time well, to focus on using information rather than looking for it, and to support learners' thinking at the levels of analysis, synthesis, and evaluation.
- **Problem-Based Learning (PBL)**
  - PBL is a curricular design that centres on an authentic problem. Students are assigned roles and presented with a problem that has no single, clear-cut solution. Students acquire content knowledge as they work toward solving the problem.

## NOTES

---

## ***SECTION 3: ASSESSMENT IN SENIOR 4 PHYSICS***

Characteristics of Effective Assessment 4

Types of Assessment 10

Assessment Strategies 11

---

## ASSESSMENT IN SENIOR 4 PHYSICS

Classroom assessment is an integral part of science instruction. Assessment could be described as the systematic process of gathering information about what a student knows, is able to do, and is learning to do. The primary purpose of classroom assessment is not to evaluate and classify student performance, but to inform teaching and improve learning, and to monitor student progress in achieving year-end learning outcomes.

Rather than emphasizing the recall of specific, detailed and unrelated ‘facts’, [assessment in science] should give greater weight to an assessment of a holistic understanding of the major scientific ideas and a critical understanding of science and scientific reasoning (Millar and Osborne, eds., 1998).

Classroom assessment is broadly defined as any activity or experience that provides information about student learning. Teachers learn about student progress not only through formal tests, examinations, and projects, but also through moment-by-moment observation of students in action. They often conduct assessment through instructional activities.

Much of students’ learning is internal. To assess students’ science knowledge, skills and strategies, and attitudes, teachers require a variety of tools and approaches. They ask questions, observe students engaged in a variety of learning activities and processes, and examine student work in progress. They also engage students in peer-assessment and self-assessment activities. The information that teachers and students gain from assessment activities informs and shapes what happens in the classroom; assessment always implies that some action will follow.

To determine whether student learning outcomes have been achieved, student assessment must be an integrated part of teaching and learning. Assessment of student learning involves careful planning and systematic implementation.

### **Planning for Assessment**

Assessment purposes, approaches, and tools should be developed with instructional approaches during the planning of the unit. In developing assessment tasks and methods, teachers determine

- what they are assessing;
- why they are assessing;
- how the assessment information will be used;
- who will receive the assessment information; and
- what assessment activities or tasks will allow students to demonstrate their learning in authentic ways.



## Characteristics of Effective Assessment

Effective assessment helps focus effort on implementing strategies to facilitate learning both inside and outside the classroom, and demonstrates the following characteristics:

- congruent with instruction, and integral to it;
- ongoing and continuous;
- based on authentic tasks and meaningful science-learning processes and contexts;
- based on criteria that students know and understand, appealing to their strengths;
- a collaborative process involving students;
- multi-dimensional, and uses a wide range of tools and methods; and
- focussed on what students have learned and can do.

## Effective Assessment Is Congruent with (and Integral to) Instruction

Assessment requires teachers to be aware continually of the purpose of instruction: What student learning outcomes am I targeting? What can students do to show what they have learned?

How teachers assess depends on what they are assessing—whether they are assessing declarative knowledge, procedural knowledge, or attitudes and habits of mind.

- **DECLARATIVE KNOWLEDGE:** If teachers wish to measure fact-based recall, declarative knowledge is the most straightforward dimension of learning to measure using traditional tools. The purpose of fostering scientific literacy, however, is not met if students simply memorize the declarative knowledge related to science; what is more important is whether students understand and are able to apply this knowledge. For example, it is more important that they understand the purposes and effects of biodiversity, that they respond to and interpret what biodiversity means for them personally and environmentally, and that they use terminology with ease to enrich their scientific communication skills, and represent—rather than reproduce—a definition of biodiversity. The challenge teachers face is to design tools that test the application of declarative knowledge.
- **PROCEDURAL KNOWLEDGE:** Tools that are designed to test declarative knowledge cannot effectively assess skills and processes. For example, rather than trying to infer student processes by looking at final products, teachers assess procedural knowledge by observing students in action, by discussing their strategies with them in conferences and interviews, and by gathering data from student reflections such as journals.
- **ATTITUDES AND HABITS OF MIND:** Attitudes and habits of mind cannot be assessed directly. They are implicit in what students do and say. Assessment tools typically describe the behaviours that reflect the attitudes and habits of scientifically literate individuals. They identify the attitudes and habits of mind that enhance science-related language learning and use, and provide students with the means to reflect on their own internal processes. For example, rather than assigning global marks for class participation, teachers assess learning outcomes related to students' effective contributions to large and small groups.

Assessment is intended to inform students of the programming emphases and to help them focus on important aspects of learning. If teachers assess only the elements that are easiest to measure, students may focus only on those things. For example, if science courses place a high value on collaboration, creativity, and divergent thinking, then assessment tools and processes must reflect those values. The ways teachers assess (what and how) inform students of what is considered important in learning.

### **Effective Assessment Is Ongoing and Continuous**

Assessment that is woven into daily instruction offers students frequent opportunities to gain feedback, to modify their learning approaches and methods, and to observe their progress. Teachers provide informal assessment by questioning students and offering comments. They also conduct formal assessments at various stages of a project or unit of study.

Continuous assessment provides ongoing opportunities for teachers to review and revise instruction, content, process emphases, and learning resources.

### **Effective Assessment Is Based on Authentic Tasks and Meaningful Science Learning Processes and Contexts**

Assessment tasks in science should be authentic and meaningful—tasks worth mastering for their own sake rather than tasks designed simply to demonstrate student proficiency for teachers and others. Through assessment, teachers discover whether students can use knowledge, processes, and resources effectively to achieve worthwhile purposes. Therefore, teachers design tasks that replicate the context in which knowledge will be applied in the world beyond the classroom.

For example, authentic science-writing tasks employ the forms used by a wide range of people (for example, scientists, journalists, filmmakers, poets, novelists, publicists, speakers, technical writers, engineers, and academics). As often as possible, students write, speak, or represent their ideas for real audiences and for real purposes. In developing assessment tasks, teachers may consider providing students with the resources people use when performing the same tasks in real-life situations related to issues in science.

Authentic assessment tasks are not only tests of the information students possess, but also of the way their understanding of a subject has deepened, and of their ability to apply learning. They demonstrate to students the relevance and importance of learning. Performance-based tests are also a way of consolidating student learning. The perennial problem teachers have with “teaching to the test” is of less concern if tests are authentic assessments of student knowledge, skills and strategies, and attitudes.

### **Effective Assessment Is Based on Criteria that Students Know and Understand, Appealing to Their Strengths**

Assessment criteria must be clearly established and made explicit to students before an assignment or test so students can focus their efforts. In addition, whenever possible, students need to be involved in developing assessment criteria. Appendix 5 includes a process for creating assessment rubrics in collaboration with students.

Students should also understand clearly what successful accomplishment of each proposed task looks like. Models of student work from previous years and other exemplars assist students in developing personal learning goals.

Each assessment task should test only those learning outcomes that have been identified to students. This means, for example, that laboratory skills tests should be devised and marked to gather information about students' laboratory skills, not their ability to express ideas effectively when writing a laboratory report.

### **Effective Assessment Is a Collaborative Process Involving Students**

The ultimate purpose of assessment is to enable students to assess themselves. The gradual increase of student responsibility for assessment is aimed at developing students' autonomy as lifelong learners. Assessment should decrease, rather than foster, students' dependence on teachers' comments for direction in learning and on marks for validation of their accomplishments.

Assessment enhances students' metacognition. It helps them make judgements about their own learning, and provides them with information for goal setting and self-monitoring.

Teachers increase students' responsibility for assessment by

- requiring students to select the products and performances to demonstrate their learning;
- involving students in developing assessment criteria whenever possible (This clarifies the goals of a particular assignment and provides students with the vocabulary to discuss their own work.);
- involving students in peer assessment, informally through peer conferences and formally using checklists;
- having students use tools for reflection and self-assessment at every opportunity (e.g., self-assessment checklists, journals, identification and selection of goals, and self-assessment of portfolio items); and
- establishing a protocol for students who wish to challenge a teacher-assigned mark (Formal appeals are valuable exercises in persuasive writing, and provide opportunities for students to examine their performance in light of the assessment criteria.).

**Effective Assessment Is Multi-Dimensional and Uses a Wide Range of Tools and Methods**

Assessment in science must recognize the complexity and holistic nature of learning for scientific literacy. To compile a complete profile of each student’s progress, teachers gather data using many different means over numerous occasions. Student profiles may involve both students and teachers in data gathering and assessment.

The following chart identifies areas for assessment and some suggested assessment instruments, tools, and methods.

<b>Data-Gathering Profile</b>			
<b>Observation of Processes</b>		<b>Observation of Products and Performances</b>	
Teacher <ul style="list-style-type: none"> <li>• checklists</li> <li>• conferences and interviews</li> <li>• anecdotal comments and records</li> <li>• reviews of drafts and revisions</li> <li>• oral presentations</li> <li>• rubrics and marking scales</li> </ul>	Students: <ul style="list-style-type: none"> <li>• journals</li> <li>• self-assessment instruments and tools (e.g., checklists, rating scales, progress charts)</li> <li>• peer-assessment instruments and tools (e.g., peer conference records, rating scales)</li> </ul>	Teacher: <ul style="list-style-type: none"> <li>• written assignments</li> <li>• demonstrations</li> <li>• presentations</li> <li>• seminars</li> <li>• projects</li> <li>• portfolios</li> <li>• student journals and notebooks</li> <li>• checklists</li> <li>• rubrics and marking scales</li> </ul>	Students: <ul style="list-style-type: none"> <li>• journals</li> <li>• self-assessment instruments and tools</li> <li>• peer-assessment instruments and tools</li> <li>• portfolio analysis</li> </ul>
<b>Classroom Tests</b>		<b>Divisional and Provincial Standard Tests</b>	
Teacher <ul style="list-style-type: none"> <li>• paper-and-pencil tests (e.g., teacher-made tests, unit tests, essay-style tests)</li> <li>• performance tests and simulations</li> <li>• rubrics and marking scales</li> </ul>	Students: <ul style="list-style-type: none"> <li>• journals</li> <li>• self-assessment instruments and tools</li> </ul>	Teacher marker: <ul style="list-style-type: none"> <li>• rubrics and marking scales</li> </ul>	

### **Effective Assessment Focusses on What Students Have Learned and Can Do—Not on What They Have Not Learned or Cannot Do**

Assessment must be equitable; it must offer opportunities for success to every student. Effective assessment demonstrates the knowledge, skills and attitudes, and strategies of each student and the progress the student is making, rather than simply identifying deficits in learning.

To assess what students have learned and can do, teachers should use a variety of strategies and approaches.

- Use a wide range of instruments to assess the multi-dimensional expressions of each student's learning, avoiding reliance upon rote memorization.
- Provide students with opportunities to learn from feedback and to refine their work, recognizing that not every assignment will be successful nor will it become part of a summative evaluation.
- Examine several pieces of student work in assessing any particular learning outcome to ensure that data collected are valid bases for making generalizations about student learning.
- Develop complete student profiles by using information from both learning outcome-referenced assessment, which compares a student's performance to predetermined criteria, and self-referenced assessment, which compares a student's performance to her or his prior performance.
- Avoid using assessment for purposes of discipline or classroom control. Ryan, Connell, and Deci (1985) found that assessment that is perceived as a tool for controlling student behaviour, meting out rewards and punishments rather than providing feedback on student learning, reduces student motivation.

Students are sometimes assigned a mark of zero for incomplete work. Averaging a zero into the student's mark, however, means the mark no longer communicates accurate information about the student's achievement of science learning outcomes. Unfinished assignments signal personal or motivational problems that should be addressed in appropriate and alternative ways.

- Allow students, when appropriate and possible, to choose how they will demonstrate their competence.
- Use assessment tools appropriate for assessing individual and unique products, processes, and performances.

### **Managing Classroom Assessment**

Assessment is one of the greatest challenges science teachers face. The practices that make science classrooms vital and effective (promoting student choice, assessing processes, and assessing the subjective aspect of learning) make assessment a complex matter.

Systems and supports that may assist teachers in managing assessment include:

- dispensing with ineffectual means of assessment;
- using time savers;
- sharing the load;
- taking advantage of technology; and
- establishing systems of recording assessment information.

### ***Dispensing with Ineffectual Means of Assessment***

Teachers should question the efficacy, for example, of writing lengthy commentaries on summative assessment of student projects. Detailed comments are best provided as formative assessment, when students can make immediate use of the feedback, and shared orally in conferences, which provide opportunities for student-teacher discussion.

The time spent in assessment should be learning time, both for teacher and student.

### ***Using Time Savers***

Many effective assessment tools are time savers. Developing checklists and rubrics is time-consuming; however, well-written rubrics may eliminate the need to write extensive comments, and may mean that student performances can be assessed largely during class time.

### ***Sharing the Load***

While the ultimate responsibility for assessment rests with the teacher, student self-assessment also provides a wealth of information. Collaborating with students to generate assessment criteria is part of effective instruction. Senior 4 students may develop checklists and keep copies of their own goals in an assessment binder for periodic conferences. Students may be willing to contribute work samples to be used as models with other classes.

Collaborating with other teachers in creating assessment tools saves time and provides opportunities to discuss assessment criteria.

### ***Taking Advantage of Technology***

Electronic tools (e.g., audio tapes, videotapes, and computer files) can assist teachers in making and recording observations. Word processors allow teachers to save, modify, and reuse task-specific checklists and rubrics.

### ***Establishing Systems for Recording Assessment Information***

Collecting data from student observations is especially challenging for Senior Years teachers, who may teach several classes of students in a given semester or term. Teachers may want to identify a group of students in each class for observation each week. Binders, card files, and electronic databases are useful for record keeping, as are self-stick notes recording brief observations on student files, which can later be transformed into anecdotal reports.

Teachers may also want to develop comprehensive forms for listing the prescribed learning outcomes, and for recording data.

This view of effective assessment in science for Manitoba reflects changes in emphases in science education at the national level and is congruent with international changes in science education. The following chart summarizes some of the changes in the area of assessment.

<b>Changing Emphases in Assessment of Student Learning*</b>	
The <i>National Science Education Standards</i> envision change throughout the system. The assessment standards encompass the following changes in emphases:	
<b>LESS EMPHASIS ON</b>	<b>MORE EMPHASIS ON</b>
Assessing what is easily measured	Assessing what is most highly valued
Assessing discrete knowledge	Assessing rich, well-structured knowledge
Assessing scientific knowledge	Assessing scientific understanding and reasoning
Assessing to learn what students do not know	Assessing to learn what students do understand
Assessing only achievement	Assessing achievement and opportunity to learn
End-of-term assessments by teachers	Students engaged in ongoing assessment of their work and that of others
Development of external assessment by measurements experts alone	Teachers involved in the development of external assessments

### Types of Assessment

Assessment can be formative, summative, or diagnostic.

- **Formative assessment** is given during the instructional unit and provides students and teachers with information about students' progress in accomplishing prescribed learning outcomes. Formative assessment also evaluates the effectiveness of instructional programming content, methods, sequence, and pace.
- **Summative assessment** (evaluation) is based on an interpretation of the assessment information collected and is given at the end of an instructional unit. It helps determine the extent of each student's achievement of prescribed learning outcomes. Evaluation should be based on a variety of assessment information. Summative assessment is used primarily to measure student achievement, to report to parent(s) or guardian(s), students, and other stakeholders, or to measure the effectiveness of instructional programming.
- **Diagnostic assessment** is given before instruction and determines student understanding of topics before learning takes place.

---

\*Reprinted with permission from *National Science Education Standards*. Copyright © 1996 the National Academy of Sciences. Courtesy of the National Academies Press, Washington, DC.

## Assessment Strategies

Senior 4 Physics suggests a range of assessment strategies. The same strategy can be used both for formative and summative assessment, depending on the purpose of the assessment. Suggested assessment strategies that can be used in the science classroom are discussed in detail in the following section. Teachers are encouraged to develop their own assessment for Senior Years science based on their students' learning requirements and the prescribed student learning outcomes.

- **Observation**

Observation of students is an integral part of the assessment process. It is most effective when focussed on skills, concepts, and attitudes. Making brief notes on index cards, self-stick notes, or grids, as well as keeping checklists, helps teachers maintain records of continuous progress and achievement.

- **Interviews**

Interviews allow teachers to assess an individual's understanding and achievement of the prescribed student learning outcome(s). Interviews provide students with opportunities to model and explain their understandings. Interviews may be both formal and informal. Posing science-related questions during planned interviews enables teachers to focus on individual student skills and attitudes. Students reveal their thinking processes and use of skills when they are questioned about how they solved problems or answered science questions. Using a prepared set of questions ensures that all interviews follow a similar structure. It is important to keep a record of student responses and/or understandings.

- **Group/Peer Assessment**

Group assessment gives students opportunities to assess how well they work within a group. Peer assessment gives them opportunities to reflect on one another's work, according to clearly established criteria. During the peer assessment process, students must reflect on their own understanding in order to evaluate the performance of another student.

- **Self-Assessment**

Self-assessment is vital to all learning and, therefore, integral to the assessment process. Each student should be encouraged to assess her or his own work. Students apply known criteria and expectations to their work and reflect on results to determine their progress toward the mastery of a prescribed learning outcome. Participation in setting self-assessment criteria and expectations helps students to see themselves as scientists and problem solvers. It is important that teachers model the self-assessment process before expecting students to assess themselves.

- **Performance Assessment/Student Demonstration**

Performance tasks provide students with opportunities to demonstrate their knowledge, thinking processes, and skill development. The tasks require the application of knowledge and skills related to a group of student learning outcomes. Performance-based tests do not test the information that students possess, but the way their understanding of a subject has been deepened, and their ability to apply their learning in a simulated performance. A scoring rubric that includes a scale for the performance of the task helps organize and interpret evidence. Rubrics allow for a continuum of performance levels associated with the task being assessed.



- **Science Journal Entries**

Science journal writing provides opportunities for students to reflect on their learning and to demonstrate their understanding using pictures, labelled drawings, and words. These journal entries can be powerful tools of formative assessment, allowing teachers to gauge a student's depth of understanding.

- **Rubrics/Checklists**

Rubrics and checklists are tools that identify the criteria upon which student processes, performances, or products will be assessed. They also describe the qualities of work at various levels of proficiency for each criterion. Rubrics and checklists may be developed in collaboration with students.

- **Visual Displays**

When students or student groups prepare visual displays, they are involved in processing information and producing a knowledge framework. The completed poster, concept map, diagram, model, et cetera, is the product with which teachers can determine what their students are thinking.

- **Laboratory Reports**

Laboratory reports allow teachers to gauge the ability of students to observe, record, and interpret experimental results. These tools can aid teachers in determining how well students understand the content.

- **Pencil-and-Paper Tasks**

Quizzes can be used as discrete assessment tools, and tests can be larger assessment experiences. These written tasks may include items such as multiple-choice questions, completion of a drawing or labelled diagram, problem solving, or long-answer questions. Ensure that both restricted and extended expository responses are included in these assessment devices.

- **Research Report/Presentation**

Research projects allow students to reach the learning outcomes in individual ways. Assessment should be built into the project at every stage, from planning to researching to presenting the finished product.

- **Interpretation of Media Reports of Science**

Short pieces extracted from newspapers could be used to assess the following: whether students understand the scientific content of the piece; whether they can identify and evaluate the possible risks and quality of the evidence presented; whether they can offer well-thought-out reactions to the claims; and, finally, whether they can give their opinion about future action that could be taken by individuals, government, or other bodies (Millar and Osborne, 1998, p. 26).

- **Demonstration of an Understanding of the Major Explanatory Stories of Science**

Questions should seek to examine observable results such as the following: whether students have understood what the particle model of matter is; whether they can give a short account of it; whether they can use it to explain everyday phenomena; and whether they can explain why it is an important idea in science (Millar and Osborne, 1998, p. 26).

- **Asking and Answering Questions Based on Data**

Such questions should assess students' abilities to represent data in a variety of ways; to formulate and interpret the messages that can be extracted from data; and to detect errors and dishonesty in the way data are presented or selected. The ability to manipulate and interpret data is a core skill that is of value, not only in science, but also in a wide range of other professions and contexts (Millar and Osborne, 1998, p. 26).

- **Recognizing the Role of Evidence**

At the heart of scientific rationality is a commitment to evidence. Contemporary science confronts the modern citizen with claims that are contested and uncertain. Questions based on historical or contemporary examples can be used to investigate students' understanding of the role of evidence in resolving competing arguments between differing theoretical accounts (Millar and Osborne, 1998, p. 26).

## NOTES

---

## ***SECTION 4: DOCUMENT ORGANIZATION***

The Guide to Reading Specific Learning Outcomes and  
Document Format 3

Document Format 4

Guide to Reading Specific Learning Outcomes 6

Skills and Attitudes Outcomes Overview 7

Specific Learning Outcomes Overview 9

---

---

## DOCUMENT ORGANIZATION

---

The prescribed learning outcomes and the suggestions for instruction, assessment, and learning resources contained within *Senior 4 Physics: A Foundation for Implementation* provide teacher educators with a plan for achieving the student learning outcomes. The document is organized by topics; Cluster 0: Skills and Attitudes is followed by the four “thematic” topics. In addition, the appendices are comprised of Student Learning Activities, Teacher Support Materials, and Blackline Masters. These complementary materials are designed to support, facilitate, and enhance student learning and assessment by being closely linked to the learning outcomes and the skills and attitudes.

### Guide to Reading the Specific Learning Outcomes and the Document Format

- The **Prescribed Learning Outcomes** identified in the header outline the intended learning to be achieved by the student by the end of the course. They include the specific learning outcomes related to the thematic topic in addition to the learning outcomes related to Cluster 0: Skills and Attitudes, selected to correspond to the Suggestions for Instruction.
- The **Suggestions for Instruction** directly relate to the achievement of the specific learning outcomes contained in the header at the top of each page.
- The **Suggestions for Assessment** of the specific learning outcomes offer assistance in identifying appropriate strategies.
- The **Suggested Learning Resources** are intended to guide and support instruction, the learning process, and student assessment.
- **Teacher Notes** boxes provide for handwritten planning hints, special interest material, and depth of treatment on certain issues related to the learning outcomes. These are incorporated as text boxes throughout.

The pages that follow provide detailed clarification on reading the document format.

General learning outcome statements connect learning in Senior 4 to the Manitoba Foundations for Science Literacy.

Prescribed learning outcome statements that define what students are expected to achieve at the end of Senior 4 Physics.

**Topic 1: Mechanics • SENIOR 4 PHYSICS**

<p><b>GENERAL LEARNING OUTCOME CONNECTION</b> Students will... Recognize both the power and limitations of science as a way of answering questions about the world and explaining natural phenomena (GLO A1)</p>	<p><b>SPECIFIC LEARNING OUTCOME</b> <b>S4P-1-1: Derive the special equations for constant acceleration.</b> Include: <math>\vec{v}_2 = \vec{v}_1 + a \Delta t</math>; <math>\Delta \vec{d} = \vec{v}_1 \Delta t + \frac{1}{2} a \Delta t^2</math>; <math>\vec{v}_2^2 = \vec{v}_1^2 + 2 a \Delta \vec{d}</math></p>
--	--

**SUGGESTIONS FOR INSTRUCTION**

**Background information and/or definitions for teachers, often beyond what students are required to know; safety information.**

**Notes to the Teacher**  
In Senior 4 Physics, the spiral treatment of kinematics is completed by introducing the special equations for constant acceleration. In this way, students progress from a mostly qualitative understanding in Senior 2 Science to the introduction of a simple mathematical model in Senior 3 Physics and, finally, to a more complex mathematical approach in Senior 4 Physics. Students should gain experience solving several different types of kinematics problems, including using the quadratic formula. There exists many opportunities throughout the course to solve problems using these equations.

**Prior Knowledge Activity**  
Students work collaboratively to complete a KWL chart (SYSTH) to review what they know from Senior 2 Science and Senior 3 Physics.

**Class Discussion**  
Provide students with a list of descriptions of motion or have students create their own list. Various descriptions are possible: walking to school, riding a bicycle up a hill, rolling a ball across the table, and so on. Students will predict the position-time and velocity-time graphs for these motions. Students can then verify their results with motion sensors and graphing calculators. (See attached chart.)

**Class Discussion**  
Consider the graphs from the student activity with the motion detector (or other similar graphs). Two of the graphs are straight-line graphs. (What kind of motion does this represent?) Mathematically speaking, straight-line graphs are useful since we can calculate the slope of the line. The slope of the straight-line position graph is average velocity (covered in Senior 3 Physics but a useful review here). Similarly, the slope of the straight-line velocity graph is average acceleration.

4 – Topic 1.1 Kinematics

Icon indicates topic (e.g., Mechanics).

Graphics that appear in the document are available for downloading at:  
<<http://www2.edu.gov.mb.ca/ks4/cur/science/>>  
Follow the "Curriculum Documents" link.

Skills and attitudes learning outcomes define expectations across all topics in Senior 4 Physics.

SENIOR 4 PHYSICS • Topic 1: Mechanics

**SKILLS AND ATTITUDES OUTCOMES**

- S4P-0-2a:** Select and use appropriate visual, numeric, graphical, and symbolic modes of representation to identify and represent relationships.
- S4P-0-2g:** Develop mathematical models involving linear, power, and/or inverse relationships among variables.

**GENERAL LEARNING OUTCOMES CONNECTION**

*Students will...*  
 Understand how stability, motion, forces, and energy transfers and transformations play a role in a wide range of natural and constructed contexts (GLO D4)  
 Describe and appreciate how the natural and constructed worlds are made up of systems and how interactions take place within and among these systems (GLO E2)

Suggestions for assessing specific learning outcomes.

**SUGGESTIONS FOR INSTRUCTION**

At this point it is very easy for students to confuse these two types of motion. Therefore, continually encourage students to differentiate between the position- and velocity-time graphs. The derivations of the kinematics equations are rooted in the position-time, velocity-time, and acceleration-time graphs for an object moving with constant acceleration. The slope and the area between the line and the horizontal axis connect displacement, velocity, and acceleration graphically. Students should carefully differentiate among the terms position, velocity, and acceleration.

The special equations of motion can be derived from the slope and area of a velocity-time graph for an object moving with a constant acceleration. The derivations are included in the appendix for teacher reference (Appendix 1.1).

**SUGGESTIONS FOR ASSESSMENT**

**Visual Display**

Use a Category Concept Map to ensure students are able to identify each symbol in each equation and its characteristics. See Appendix 1.2 for the map.

**Science Journal Entries**

Students use process notes (SYSTH 13.14) to detail the derivations of the special equations.

**Pencil-and-Paper Tasks**

Given a graph of velocity-time, students will

$$\text{derive } \vec{a} = \frac{\Delta \vec{v}}{\Delta t}; \Delta \vec{d} = \vec{v}_i \Delta t + \frac{1}{2} \vec{a} \Delta t.$$

Students will algebraically derive

$$v_2^2 = v_1^2 + 2a\Delta d \text{ from } \vec{a} = \frac{\Delta \vec{d}}{\Delta t} \text{ and } \Delta \vec{d} = \left( \frac{\vec{v}_1 + \vec{v}_2}{2} \right) \Delta t.$$

**SUGGESTED LEARNING RESOURCES**

BLM 3-1: Kinematics Equations, *Physics 12*, McGraw-Hill Ryerson, 2003

QuickLab, Rocket Motion, p. 59, *Physics 12*, McGraw-Hill Ryerson, 2003

Conceptual Graphing, p. 17, Lab Manual. *Conceptual Physics*, Pearson, 2002



Suggestions for learning resources, including print and information technology resources.

**Guide to Reading Specific Learning Outcomes**

Topic 1: Mechanics • SENIOR 4 PHYSICS

**GENERAL LEARNING OUTCOME CONNECTION**

Students will...

Recognize both the power and limitations of science as a way of answering questions about the world and explaining natural phenomena (GLO A1)

**SPECIFIC LEARNING OUTCOME**

**S4P-1-1: Derive the special equations for constant acceleration.**

Include:  $\vec{v}_2 = \vec{v}_1 + \vec{a} \Delta t$ ;  
 $\Delta \vec{d} = \vec{v}_1 \Delta t + \frac{1}{2} \vec{a} \Delta t^2$ ;  
 $\vec{v}_2^2 = \vec{v}_1^2 + 2 \vec{a} \Delta \vec{d}$

**SUGGESTIONS FOR INSTRUCTION**

Action	Position-Time Graph	Velocity-Time Graph
A person walks away from the sensor at a constant velocity.		
A person walks towards the sensor at a constant velocity.		

**SPECIFIC LEARNING OUTCOME**

**S4P-1-1: Derive the special equations for constant acceleration.**

Include:  $\vec{v}_2 = \vec{v}_1 + \vec{a} \Delta t$ ;  
 $\Delta \vec{d} = \vec{v}_1 \Delta t + \frac{1}{2} \vec{a} \Delta t^2$ ;  
 $\vec{v}_2^2 = \vec{v}_1^2 + 2 \vec{a} \Delta \vec{d}$

First alphanumeric indicates course (Senior 4 Physics); second digit indicates topic number; third digit(s) indicates specific learning outcome number

Examples: Provide ideas of what could be included (non-mandatory).  
*None given in this outcome.*

Include: Indicates a mandatory component of the specific learning outcome.



## Skills and Attitudes Outcomes Overview

Cluster 0 in Senior 4 Physics comprises four categories of specific learning outcomes that describe the skills and attitudes involved in scientific inquiry and the decision-making process for STSE issues. In Grades 5 to Senior 2, students develop scientific inquiry through the development of an hypothesis/prediction, the identification and treatment of variables, and the formation of conclusions. Students begin to make decisions based on scientific facts and refine their decision-making skills as they progress through the grades, gradually becoming more independent. Students also acquire key attitudes, an initial awareness of the nature of science, and other skills related to research, communication, the use of information technology, and co-operative learning.

In Senior 4 Physics, students continue to use scientific inquiry as an important process in their science learning, but also recognize that STSE issues require a more sophisticated treatment through the decision-making process.

Teachers should select appropriate contexts to introduce and reinforce scientific inquiry, the decision-making process, and positive attitudes within the thematic topics 1 to 4 throughout the school year. To assist in planning and to facilitate curricular integration, many specific learning outcomes within the Skills and Attitudes cluster can link to specific learning outcomes in other subject areas, specifically English Language Arts (ELA) and mathematics (Math).

### Nature of Science

- S4P-0-1a Explain the roles of theory, evidence, and models in the development of scientific knowledge.
- S4P-0-1b Describe the importance of peer review in the evaluation and acceptance of scientific theories, evidence, and knowledge claims.
- S4P-0-1c Relate the historical development of scientific ideas and technology to the form and function of scientific knowledge today.
- S4P-0-1d Describe how scientific knowledge changes as new evidence emerges and/or new ideas and interpretations are advanced.
- S4P-0-1e Differentiate between how scientific theories explain natural phenomena and how scientific laws identify regularities and patterns in nature.

### Inquiry Skills

- S4P-0-2a Select and use appropriate visual, numeric, graphical, and symbolic modes of representation to identify and represent relationships.
- S4P-0-2b Propose problems, state hypotheses, and plan, implement, adapt, or extend procedures to carry out an investigation where required.
- S4P-0-2c Formulate operational definitions of major variables or concepts.
- S4P-0-2d Estimate and measure accurately using SI units.

- S4P-0-2e Evaluate the relevance, reliability, and adequacy of data and data-collection methods.  
Include: discrepancies in data and sources of error
- S4P-0-2f Record, organize, and display data using an appropriate format.  
Include: labelled diagrams, tables, graphs
- S4P-0-2g Develop a mathematical models involving linear, power, and/or inverse relationships among variables.
- S4P-0-2h Analyze problems using vectors.  
Include: Adding and subtracting vectors in straight lines, at right angles, and at non-orthogonal angles
- S4P-0-2i Select and integrate information obtained from a variety of sources.  
Include: print, electronic, specialists, or other resource people

### **Science, Technology, Society, and the Environment (STSE)**

- S4P-0-3a Analyze, from a variety of perspectives, the risks and benefits to society and the environment when applying scientific knowledge or introducing technology.
- S4P-0-3b Describe examples of how technology has evolved in response to scientific advances, and how scientific knowledge has evolved as the result of new innovations in technology.
- S4P-0-3c Identify social issues related to science and technology, taking into account human and environmental needs and ethical considerations.
- S4P-0-3d Use the decision-making process to address an STSE issue.
- S4P-0-3e Identify a problem, initiate research, and design a technological or other solution to address the problem.

### **Attitudes**

- S4P-0-4a Demonstrate work habits that ensure personal safety, the safety of others, and consideration of the environment.
- S4P-0-4b Work co-operatively with a group to identify prior knowledge, initiate and exchange ideas, propose problems and their solution, and carry out investigations.
- S4P-0-4c Demonstrate confidence in their ability to carry out investigations in science and to address STSE issues.
- S4P-0-4d Develop a sense of personal and shared responsibility for the impact of humans on the environment, and demonstrate concern for social and environmental consequences of proposed actions.

- S4P-0-4e Demonstrate a continuing and more informed interest in science and science-related issues.
- S4P-0-4f Value skepticism, honesty, accuracy, precision, perseverance, and open-mindedness as scientific and technological habits of mind.

## Specific Learning Outcomes Overview

The Specific Learning Outcomes (SLOs) identified here constitute the intended learning to be achieved by the student by the end of a complete instructional and assessment sequence for Senior 4 Physics. These statements clearly define what students of Senior 4 Physics are expected to achieve and/or are able to perform at the end of the course. When combined with the Skills and Attitudes SLOs that appear previously, these student-specific learning outcomes constitute the bases upon which assessment and instructional design have their source.

### Topic One: Mechanics

#### Topic 1.1: Kinematics

- S4P-1-1 Derive the special equations for constant acceleration.

$$\text{Include: } \vec{a} = \frac{\Delta \vec{v}}{\Delta t}; \Delta \vec{d} = \vec{v}_1 \Delta t + \frac{1}{2} \vec{a} \Delta t^2; v_2^2 = v_1^2 + 2a\Delta d$$

- S4P-1-2 Solve problems for objects moving in a straight line with a constant acceleration.

$$\text{Include: } \vec{v}_2 = \vec{v}_1 + \vec{a} \Delta t; \Delta \vec{d} = \vec{v}_1 \Delta t + \frac{1}{2} \vec{a} \Delta t^2; v_2^2 = v_1^2 + 2a\Delta d; \Delta \vec{d} = \left( \frac{\vec{v}_1 + \vec{v}_2}{2} \right) \Delta t$$

- S4P-1-3 Solve relative motion problems for constant velocities using vectors.

#### Topic 1.2: Dynamics

- S4P-1-4 Solve vector problems for objects in equilibrium.

- S4P-1-5 Calculate the forces acting on an object resting on an inclined plane.

Include: normal force, friction, components of the gravitational force (mg)

- S4P-1-6 Calculate the components of  $\vec{F}_{\text{gravity}}$  exerted on an object resting on an inclined plane.

- S4P-1-7 Solve problems with  $\vec{F}_{\text{friction}}$  for objects on a horizontal surface and on an inclined plane.

Include: coefficient of friction

- S4P-1-8 Solve problems using  $\vec{F}_{\text{net}} = m \vec{a}$  where  $\vec{F}_{\text{net}} = \vec{F}_{\text{applied}} + \vec{F}_{\text{friction}}$  and using kinematics equations from above.

Include:  $\vec{F}_{\text{applied}}$  at an angle to horizontal motion; combined mass systems;  $\vec{F}_{\text{applied}}$  on an inclined plane; forces acting at various angles on a body

- S4P-1-9 Perform an experiment to investigate forces acting on an object.

### Topic 1.3: Momentum

- S4P-1-10 Derive the impulse-momentum equation from Newton's second law.
- S4P-1-11 Determine impulse from the area under a force-time graph.  
Include: constant positive and negative force, uniformly changing force
- S4P-1-12 Experiment to illustrate the Law of Conservation of Momentum in one and two dimensions.
- S4P-1-13 Solve problems using the impulse-momentum equation and the Law of Conservation of Momentum.
- S4P-1-14 Relate the impulse-momentum equation to real-life situations.  
*Examples: hitting a ball, catching a ball*

### Topic 1.4: Projectile Motion

- S4P-1-15 Solve simple free-fall problems using the special equations for constant acceleration.  
Include: horizontal and vertical components of motion of the curved path of a projectile (without air resistance).
- S4P-1-16 Draw free-body diagrams for a projectile at various points along its path (with or without air resistance).
- S4P-1-17 Calculate the horizontal and vertical components with respect to velocity and position of a projectile at various points along its path.
- S4P-1-18 Solve problems for projectiles launched horizontally and at various angles to the horizontal to calculate maximum height, range, and overall time of flight of the projectile.

### Topic 1.5: Circular Motion

- S4P-1-19 Explain qualitatively why an object moving at constant speed in a circle is accelerating toward the centre of the circle.
- S4P-1-20 Discuss the centrifugal effects with respect to Newton's laws.
- S4P-1-21 Draw free-body diagrams of an object moving in uniform circular motion.
- S4P-1-22 Experiment to determine the mathematical relationship between period and frequency and one or more of the following: centripetal force, mass, and radius.
- S4P-1-23 Derive an equation for the constant speed and acceleration of an object moving in a circle  $\left( \vec{v} = \frac{2\pi r}{T}, a = \frac{v^2}{R} \right)$ .
- S4P-1-24 Solve problems for an object moving with a constant speed in a circle using  $a = \frac{v^2}{R}$ ,  $\vec{v} = \frac{2\pi r}{T}$ , and  $\vec{F}_{\text{net}} = m\vec{a}$ .

**Topic 1.6: Work and Energy**

- S4P-1-25 Define work as the product of displacement and the component of force parallel to the displacement when the force is constant.
- S4P-1-26 Determine work from the area under the force-position graph for any force.  
Include: positive or negative force, uniformly changing force
- S4P-1-27 Describe work as a transfer of energy.  
Include: positive and negative work, kinetic energy, conservation of energy
- S4P-1-28 Give examples of various forms of energy and describe qualitatively the means by which they can perform work.
- S4P-1-29 Derive the equation for kinetic energy using  $W = \vec{F} \cdot \Delta \vec{d} \cos \theta$  and kinematics equations.
- S4P-1-30 Derive the equation for gravitational potential energy near the surface of the Earth ( $E_p = mgh$ ).
- S4P-1-31 Experiment to determine Hooke's Law ( $\vec{F} = -k \vec{x}$ ).
- S4P-1-32 Derive an equation for the potential energy of a spring, using Hooke's law and a force-displacement graph.
- S4P-1-33 Solve problems related to the conservation of energy.  
Include: gravitational and spring potential, and kinetic energy

**Topic 2: Fields****Topic 2.1: Exploration of Space**

- S4P-2-1 Identify and analyze issues pertaining to space exploration.  
*Examples: scale of the universe, technological advancement, promotion of global co-operation, social and economic benefits, allocation of resources shifted away from other pursuits, possibility of disaster*
- S4P-2-2 Describe planetary motion using Kepler's three laws.  
*Examples: relate Kepler's Third Law to objects other than planets, such as comets, satellites, and spacecraft*
- S4P-2-3 Outline Newton's Law of Universal Gravitation and solve problems using  
$$F_g = \frac{Gm_1m_2}{r^2}.$$
- S4P-2-4 State the gravitational potential energy as the area under the force-separation curve and solve problems using  $E_g = \frac{-Gm_1m_2}{r}$ .
- S4P-2-5 Solve problems for the escape velocity of a spacecraft.  
Include: Law of Conservation of Energy, binding energy

### Topic 2.2: Low Earth Orbit

- S4P-2-6 Compare the Law of Universal Gravitation with the weight (mg) of an object at various distances from the surface of the Earth and describe the gravitational field as  $g = \frac{Gm_{\text{Earth}}}{r^2}$ .
- S4P-2-7 Outline Newton's thought experiment regarding how an artificial satellite can be made to orbit the Earth.
- S4P-2-8 Use the Law of Universal Gravitation and circular motion to calculate the characteristics of the motion of a satellite.  
Include: orbital period, speed, altitude above a planetary surface, mass of the central body, and the location of geosynchronous satellites
- S4P-2-9 Define microgravity as an environment in which the apparent weight of a system is smaller than its actual weight.
- S4P-2-10 Describe conditions under which microgravity can be produced.  
*Examples: jumping off a diving board, roller-coaster, free fall, parabolic flight, orbiting spacecraft*
- S4P-2-11 Outline the factors involved in the re-entry of an object into Earth's atmosphere.  
Include: friction and g-forces
- S4P-2-12 Describe qualitatively some of the technological challenges to exploring deep space.  
*Examples: communication, flyby and the "slingshot" effect, Hohmann Transfer orbits (least-energy orbits)*

### Topic 2.3: Electric and Magnetic Fields

- S4P-2-13 Compare and contrast the inverse square nature of gravitational and electric fields.
- S4P-2-14 State Coulomb's Law and solve problems for more than one electric force acting on a charge.  
Include: one and two dimensions
- S4P-2-15 Illustrate, using diagrams, how the charge distribution on two oppositely charged parallel plates results in a uniform field.
- S4P-2-16 Derive an equation for the electric potential energy between two oppositely charged parallel plates ( $E_e = qE\Delta d$ ).
- S4P-2-17 Describe electric potential as the electric potential energy per unit charge.
- S4P-2-18 Identify the unit of electric potential as the volt.
- S4P-2-19 Define electric potential difference (voltage) and express the electric field between two oppositely charged parallel plates in terms of voltage and the separation between the plates  $\left( \varepsilon = \frac{\Delta V}{d} \right)$ .

- S4P-2-20 Solve problems for charges moving between or through parallel plates.
- S4P-2-21 Use hand rules to describe the directional relationships between electric and magnetic fields and moving charges.
- S4P-2-22 Describe qualitatively various technologies that use electric and magnetic fields.  
*Examples: electromagnetic devices (such as a solenoid, motor, bell, or relay), cathode ray tube, mass spectrometer, antenna*

### Topic 3: Electricity

#### Topic 3.1: Electric Circuits

- S4P-3-1 Describe the origin of conventional current and relate its direction to the electron flow in a conductor.
- S4P-3-2 Describe the historical development of Ohm's Law.  
 Include: contributions of Gray, Ohm, Joule, and Kirchoff
- S4P-3-3 Investigate the relationships among resistance and resistivity, length, cross-section, and temperature.  
 Include:  $R = \frac{\rho L}{A}$
- S4P-3-4 Demonstrate the ability to construct circuits from schematic diagrams for series, parallel, and combined networks.  
 Include: correct placement of ammeters and voltmeters
- S4P-3-5 Calculate the total resistance for resistors in series and resistors in parallel.
- S4P-3-6 Calculate the resistance, current, voltage, and power for series, parallel, and combined networks.  
 Include:  $P = IV$ ,  $P = I^2R$ , and  $P = \frac{V^2}{R}$

#### Topic 3.2: Electromagnetic Induction

- S4P-3-7 Define magnetic flux ( $\Phi = B_{\perp}A$ ).
- S4P-3-8 Demonstrate how a change in magnetic flux induces voltage.
- S4P-3-9 Calculate the magnitude of the induced voltage in coils using  $V = \frac{N\Delta\Phi}{\Delta t}$ .
- S4P-3-10 Outline Lenz's Law and apply to related problems.
- S4P-3-11 Describe the operation of an AC generator.
- S4P-3-12 Graph voltage versus angle for the AC cycle.
- S4P-3-13 Describe the operation of transformers.

S4P-3-14 Solve problems using the transformer ratio of  $\frac{V_p}{V_s} = \frac{N_p}{N_s}$ .

S4P-3-15 Describe the generation, transmission, and distribution of electricity in Manitoba.

Include: step-up and step-down transformers, power transfer, High Voltage Direct Current

## Topic 4: Medical Physics

### Topic 4.1: Medical Physics

S4P-4-1 Describe the nuclear model of the atom.

Include: proton, neutron, nucleus, nuclear forces, stability, isotope, mass number, electron, ion

S4P-4-2 Define radioactivity as a nuclear change that releases energy.

Include: Becquerel units, radioactive decay, half life

S4P-4-3 Perform decay calculations using integer numbers of half life.

S4P-4-4 Describe the following types of radiation: alpha, beta, and electromagnetic radiation.

Include: particle radiation, wave radiation, electromagnetic spectrum, linear energy transfer

S4P-4-5 Compare and contrast sources and characteristics of ionizing radiation and non-ionizing radiation.

Include: NORM (Naturally Occurring Radioactive Materials), radon, background radiation, incandescent light bulb, hot objects

S4P-4-6 Describe various applications of non-ionizing radiation.

*Examples: communications, microwave oven, laser, tanning bed*

S4P-4-7 Describe various applications of ionizing radiation.

*Examples: food irradiation, sterilization, smoke alarm*

S4P-4-8 Describe the effects of non-ionizing and ionizing radiation on the human body.

Include: equivalency of sievert (Sv) and rem units, solar erythema (sunburn)

S4P-4-9 Research, identify, and examine the application of radiation to diagnostic imaging and treatment techniques.

*Examples: nuclear medicine imaging techniques such as MRI, ultrasound, endoscopy, X-ray, CT scanning, PET, heavy isotopes such as Ba; nuclear medicine therapies such as brachithery, external beam, gamma knife*



---

## ***TOPIC 1: MECHANICS***

- 1.1: Kinematics
  - 1.2: Dynamics
  - 1.3: Momentum
  - 1.4: Projectile Motion
  - 1.5: Circular Motion
  - 1.6: Work and Energy
-

---

## TOPIC 1.1: KINEMATICS

S4P-1-1 Derive the special equations for constant acceleration.

Include:  $\vec{v}_2 = \vec{v}_1 + \vec{a} \Delta t$ ;  $\Delta \vec{d} = \vec{v}_1 \Delta t + \frac{1}{2} \vec{a} \Delta t^2$ ;  $v_2^2 = v_1^2 + 2 \vec{a} \Delta \vec{d}$

S4P-1-2 Solve problems for objects moving in a straight line with a constant acceleration.

Include:  $\vec{v}_2 = \vec{v}_1 + \vec{a} \Delta t$ ;  $\Delta \vec{d} = \vec{v}_1 \Delta t + \frac{1}{2} \vec{a} \Delta t^2$ ;

$$v_2^2 = v_1^2 + 2a\Delta d; \Delta \vec{d} = \left( \frac{\vec{v}_1 + \vec{v}_2}{2} \right) \Delta t$$

S4P-1-3 Solve relative motion problems for constant velocities using vectors.

---

**GENERAL LEARNING OUTCOME CONNECTION**

*Students will...*

Recognize both the power and limitations of science as a way of answering questions about the world and explaining natural phenomena (GLO A1)

**SPECIFIC LEARNING OUTCOME**



**S4P-1-1: Derive the special equations for constant acceleration.**

Include:  $\vec{v}_2 = \vec{v}_1 + \vec{a} \Delta t;$

$$\Delta \vec{d} = \vec{v}_1 \Delta t + \frac{1}{2} \vec{a} \Delta t^2;$$

$$v_2^2 = v_1^2 + 2 \vec{a} \Delta \vec{d}$$

**SUGGESTIONS FOR INSTRUCTION**

**Entry Level Knowledge**

In Senior 2 Science, students were introduced to kinematics using the context of driving an automobile. The approach was mostly qualitative with an emphasis on the visual mode of representation. Students learned the definitions for average velocity and acceleration. In Senior 3 Physics, students extended this knowledge to focus on linear relations with an emphasis on graphical analysis using slope. Problem solving in Senior 3 Physics used the concept of average velocity.

**Notes to the Teacher**

In Senior 4 Physics, the spiral treatment of kinematics is completed by introducing the special equations for constant acceleration. In this way, students progress from a mostly qualitative understanding in Senior 2 Science to the introduction of a simple mathematical model in Senior 3 Physics and, finally, to a more complex mathematical approach in Senior 4 Physics. Students should gain experience solving several different types of kinematics problems, including using the quadratic formula. There exists many opportunities throughout the course to solve problems using these equations.

**Prior Knowledge Activity**

Students work collaboratively to complete a KWL chart (SYSTH) to review what they know from Senior 2 Science and Senior 3 Physics.

**Class Discussion**

Provide students with a list of descriptions of motion or have students create their own list. Various descriptions are possible: walking to school, riding a bicycle up a hill, rolling a ball across the table, and so on. Students will predict the position-time and velocity-time graphs for these motions. Students can then verify their results with motion sensors and graphing calculators. (See attached chart.)

**Class Discussion**

Consider the graphs from the student activity with the motion detector (or other similar graphs). Two of the graphs are straight-line graphs. (What kind of motion does this represent?) Mathematically speaking, straight-line graphs are useful since we can calculate the slope of the line. The slope of the straight-line position graph is average velocity (covered in Senior 3 Physics but a useful review here). Similarly, the slope of the straight-line velocity graph is average acceleration.

Representative sample graphs appear on pages 6 and 7.



**SKILLS AND ATTITUDES OUTCOMES**

**S4P-0-2a:** Select and use appropriate visual, numeric, graphical, and symbolic modes of representation to identify and represent relationships.

**S4P-0-2g:** Develop mathematical models involving linear, power, and/or inverse relationships among variables.

**GENERAL LEARNING OUTCOMES CONNECTION**

*Students will...*

Understand how stability, motion, forces, and energy transfers and transformations play a role in a wide range of natural and constructed contexts (GLO D4)

Describe and appreciate how the natural and constructed worlds are made up of systems and how interactions take place within and among these systems (GLO E2)

**SUGGESTIONS FOR INSTRUCTION**

At this point it is very easy for students to confuse these two types of motion. Therefore, continually encourage students to differentiate between the position- and velocity-time graphs. The derivations of the kinematics equations are rooted in the position-time, velocity-time, and acceleration-time graphs for an object moving with constant acceleration. The slope and the area between the line and the horizontal axis connect displacement, velocity, and acceleration graphically. Students should carefully differentiate among the terms position, velocity, and acceleration.

The special equations of motion can be derived from the slope and area of a velocity-time graph for an object moving with a constant acceleration. The derivations are included in the appendix for teacher reference (Appendix 1.1).

**SUGGESTIONS FOR ASSESSMENT**
**Visual Display**

Use a Category Concept Map to ensure students are able to identify each symbol in each equation and its characteristics. See Appendix 1.2 for the map.

**Science Journal Entries**

Students use process notes (SYSTH 13.14) to detail the derivations of the special equations.

**Pencil-and-Paper Tasks**

Given a graph of velocity-time, students will

derive  $\vec{a} = \frac{\Delta \vec{v}}{\Delta t}$ ;  $\Delta \vec{d} = \vec{v}_1 \Delta t + \frac{1}{2} \vec{a} \Delta t$ .

Students will algebraically derive

$$v_2^2 = v_1^2 + 2a\Delta d \text{ from } \vec{a} = \frac{\Delta \vec{d}}{\Delta t} \text{ and } \Delta \vec{d} = \left( \frac{\vec{v}_1 + \vec{v}_2}{2} \right) \Delta t.$$

**SUGGESTED LEARNING RESOURCES**

BLM 3-1: Kinematics Equations, *Physics 12*, McGraw-Hill Ryerson, 2003

QuickLab, Rocket Motion, p. 59, *Physics 12*, McGraw-Hill Ryerson, 2003

Conceptual Graphing, p. 17, Lab Manual, *Conceptual Physics*, Pearson, 2002



**GENERAL LEARNING OUTCOME CONNECTION**

Students will...

Recognize both the power and limitations of science as a way of answering questions about the world and explaining natural phenomena (GLO A1)

**SPECIFIC LEARNING OUTCOME**



**S4P-1-1: Derive the special equations for constant acceleration.**

Include:  $\vec{v}_2 = \vec{v}_1 + \vec{a} \Delta t;$

$$\Delta \vec{d} = \vec{v}_1 \Delta t + \frac{1}{2} \vec{a} \Delta t^2;$$

$$v_2^2 = v_1^2 + 2 a \Delta d$$

**SUGGESTIONS FOR INSTRUCTION**

Action	Position-Time Graph	Velocity-Time Graph
A person walks away from the sensor at a constant velocity.		
A person walks towards the sensor at a constant velocity.		



**SKILLS AND ATTITUDES OUTCOMES**

**S4P-0-2a:** Select and use appropriate visual, numeric, graphical, and symbolic modes of representation to identify and represent relationships.

**S4P-0-2g:** Develop mathematical models involving linear, power, and/or inverse relationships among variables.

**GENERAL LEARNING OUTCOMES CONNECTION**

*Students will...*

Understand how stability, motion, forces, and energy transfers and transformations play a role in a wide range of natural and constructed contexts (GLO D4)

Describe and appreciate how the natural and constructed worlds are made up of systems and how interactions take place within and among these systems (GLO E2)

**SUGGESTIONS FOR INSTRUCTION**

**SUGGESTIONS FOR ASSESSMENT**

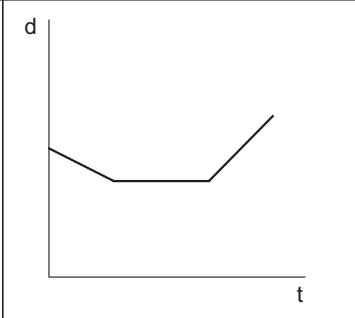
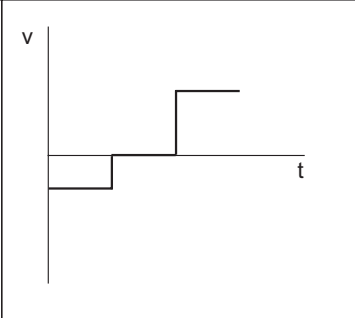
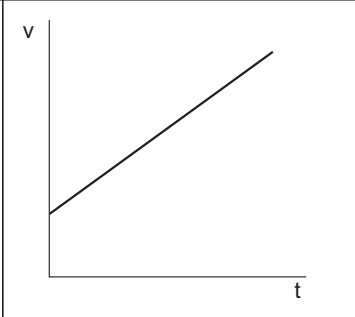
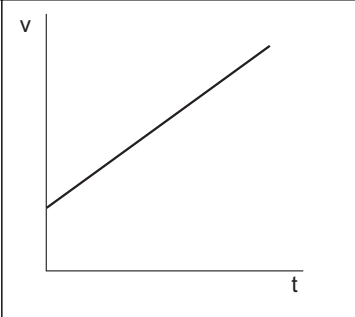
Action	Position-Time Graph	Velocity-Time Graph
A person walks towards the sensor at a constant velocity, pauses, and then walks away from the sensor at a constant speed (can be the same as the initial speed or different).		
A person walks away from the sensor, slowly accelerating to a run.		



**GENERAL LEARNING OUTCOME CONNECTION**

*Students will...*

Recognize both the power and limitations of science as a way of answering questions about the world and explaining natural phenomena (GLO A1)

**SPECIFIC LEARNING OUTCOME**



**S4P-1-2: Solve problems for objects moving in a straight line with a constant acceleration.**

Include:  $\vec{v}_2 = \vec{v}_1 + a \Delta t$ ;  $\Delta \vec{d} = \vec{v}_1 \Delta t + \frac{1}{2} a \Delta t^2$ ;

$$v_2^2 = v_1^2 + 2a\Delta d; \Delta \vec{d} = \left( \frac{\vec{v}_1 + \vec{v}_2}{2} \right) \Delta t$$

**SUGGESTIONS FOR INSTRUCTION**

**Entry Level Knowledge**

Students worked with the basic equations of motion in Senior 3 Physics. Problems were solved using multiple steps and the concept of average velocity.

**Notes to the Teacher**

The equations involving power relationships are new to the students. In many cases, problems that may have required two separate steps in Senior 3 Physics can now be solved using only one equation. Problem solving using the special equations can be spread throughout the course.

Instruct students in a systematic approach to solving word problems. A common approach includes the following steps:

- After reading the problem carefully, draw a diagram of the situation.
- Identify the given information.

- Identify the unknown quantities.
- Select the most convenient equation, substitute, and solve for the unknown.
- Check the final answer using different equations.
- Check units and directions for all vector quantities. Use unit analysis to reinforce the comprehension of the concepts of kinematics.

Students should experience a variety of problems. Illustrative examples can be found in Appendix 1.3. Students are always interested in problems that are framed in a familiar context such as flight, sports, or biomechanics.

A Three-Point Approach frame (SYSTH) can be used to define the terms in this section.

The IDEAL problem-solving frame can be used to aid students with solving kinematics problems.



**SKILLS AND ATTITUDES OUTCOMES**

**S4P-0-2a:** Select and use appropriate visual, numeric, graphical, and symbolic modes of representation to identify and represent relationships.

**S4P-0-2g:** Develop mathematical models involving linear, power, and/or inverse relationships among variables.

**GENERAL LEARNING OUTCOMES CONNECTION**

*Students will...*

Understand how stability, motion, forces, and energy transfers and transformations play a role in a wide range of natural and constructed contexts (GLO D4)

Describe and appreciate how the natural and constructed worlds are made up of systems and how interactions take place within and among these systems (GLO E2)

**SUGGESTIONS FOR INSTRUCTION**

**SUGGESTIONS FOR ASSESSMENT**

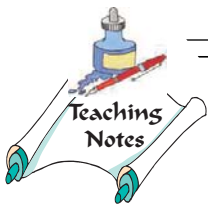

A large empty rectangular box intended for handwritten notes or additional instructions.

**Pencil-and-Paper Tasks**

Students solve a variety of problems using the special equations of constant acceleration.

**Science Journal Entries**

Students write process notes showing their reasoning for problem solutions.

**Asking and Answering Questions Based on Data**

Students use real-life situations to check their understanding of acceleration. Pictures of the situation can be interpreted into graphical representations of the motion, which can then be expressed mathematically through the kinematics equations.





**GENERAL LEARNING OUTCOME CONNECTION**

*Students will...*

Demonstrate appropriate scientific inquiry skills when seeking answers to questions (GLO C2)

**SPECIFIC LEARNING OUTCOME**

**S4P-1-3: Solve relative motion problems for constant velocities using vectors.**



**SUGGESTIONS FOR INSTRUCTION**

**Entry Level Knowledge**

In Senior 3 Physics, students added and subtracted collinear vectors and perpendicular vectors. Students also determined the components of vectors.

**Notes to Teacher**

At this time the vector case is extended to adding and subtracting vectors at any angle. The component method should be used.

Relative motion occurs when an object appears to have one motion to one observer and a different motion to a second observer, depending on how the two observers are moving with respect to one another. Examples include a boat crossing a river or an airplane flying through the air. The motion, as observed from the shore or the ground, is the vector sum of the two given motions.

**Class Discussion**

Introduce the concept of relative motion with simple examples of collinear motion. Encourage students to put themselves in each of the following situations and describe the velocity of the moving object with respect to their frame of reference.

**Case One**

The police are sitting in their car on the side of the road with a radar gun. A motorist is speeding toward the police car at a rate of 135 km/h [E]. If you are in the police car, what do you perceive the apparent velocity of the motorist to be? (135 km/h [E])

**Case Two**

A sports car is travelling east on Highway #1 at 140 km/h and a semi-trailer truck is travelling west on the same highway at 110 km/h. If you were in the sports car, what is the apparent velocity of the truck? (250 km/h [W])

If you were the truck driver, what is the apparent velocity of the sports car? (250 km/h [E])

**Case Three**

A delivery truck is travelling down Portage Avenue at 60 km/h [W]. A car is passing the delivery truck at a speed of 70 km/h [W]. If you were the truck driver, what is the apparent velocity of the car passing you? (10 km/h [W])

If you were a passenger in the car, what is the apparent velocity of the truck you are passing? (10 km/h [E])

Finally, if you are the police sitting on the side of Portage Avenue, what is the apparent velocity of the car? (70 km/h [W])



**SKILLS AND ATTITUDES OUTCOME**

**S4P-0-2h:** Analyze problems using vectors.

Include: Adding and subtracting vectors in straight lines, at right angles, and at non-orthogonal angles

**GENERAL LEARNING OUTCOME CONNECTION**

*Students will...*

Understand the properties and structures of matter as well as various common manifestations and applications of the actions and interactions of matter (GLO D3)

**SUGGESTIONS FOR INSTRUCTION**

Another common example of collinear motion is a boat travelling on a river, heading straight upstream. Following this discussion, introduce students to motion that is not collinear. This example could then be extended to a boat heading straight across the river. In these cases, the vectors are at right angles. The next extension would be a boat heading across the river at some angle other than perpendicular to the shore. Remind students that the motion of the boat crossing a river remains constant irrespective of the motion of the river.

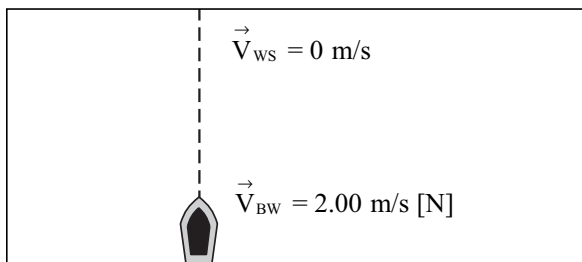

Diagram showing boat travelling in still water across a river.

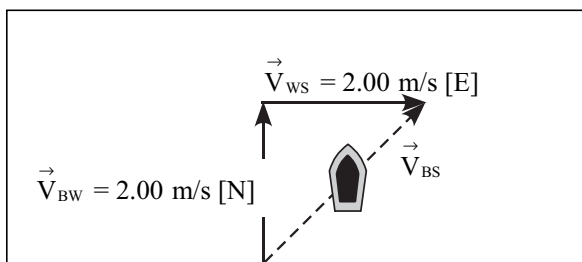

Diagram showing boat travelling across a river that has a current.

**SUGGESTIONS FOR ASSESSMENT**

**Science Journal Entries**

Students write about swimming across a river that has a current flowing. Students can determine under what conditions they can swim with a resultant velocity directly across the river. Compare the difference between swimming in a body of water with a current as opposed to a still body of water.

Students write process notes (SYSTH) to describe the steps followed to solve vector problems using the component method.

Students describe situations they have experienced that involve relative motion.

Students write process notes for solving a vector addition question using components.

Students make a concept map relating these terms from this vectors unit:

- |                     |                  |
|---------------------|------------------|
| frames of reference | relative motion  |
| position            | velocity         |
| acceleration        | average velocity |
| components          | addition         |

**Performance Assessment**

Students work in small groups to generate a series of relative motion problems, providing the questions and solutions to these problems. Students in the groups exchange problems and have their group solve the problems.

Students use a computer software simulation program, such as *Interactive Physics*, to demonstrate the concept of relative motion.



**GENERAL LEARNING OUTCOME CONNECTION**

*Students will...*

Demonstrate appropriate scientific inquiry skills when seeking answers to questions (GLO C2)

**SPECIFIC LEARNING OUTCOME**

**S4P-1-3: Solve relative motion problems for constant velocities using vectors.**



---

**SUGGESTIONS FOR INSTRUCTION**

Note that the boat has the same velocity in still water and when travelling in a river with a current. Use subscripts to help identify the variables. For example, if a boat is crossing the river, the boat's velocity relative to the water can be noted as  $v_{BW}$ . Then the velocity of the current with respect to the ground is  $v_{WG}$ . The addition of these two vectors will result in the velocity of the boat relative to the ground,  $v_{BG}$ .

The common reference to the water is the link between the vectors.

**Teacher Demonstration**

Use the videodisc *Physics: Cinema Classics* to show the independent nature of vectors. Set up a demonstration where a toy bulldozer is travelling perpendicularly across a piece of rolled paper that is pulled along the floor at a constant velocity. This motion can be analyzed using a video camera suspended overhead.

The *Interactive Physics* software program can be used to show the vector components of relative motion for a boat crossing a river. The velocity of the boat can be changed to show the effect of the direction that the boat takes (its heading).

Many Java applets exist on the Internet to describe and interact with relative motion examples. Conduct an Internet search using "Relative, Motion, Java applets" as your search string for information.



**SKILLS AND ATTITUDES OUTCOME**

**S4P-0-2h:** Analyze problems using vectors.

Include: Adding and subtracting vectors in straight lines, at right angles, and at non-orthogonal angles.

**GENERAL LEARNING OUTCOME CONNECTION**

*Students will...*

Understand the properties and structures of matter as well as various common manifestations and applications of the actions and interactions of matter (GLO D3)

**SUGGESTIONS FOR INSTRUCTION**

**SUGGESTIONS FOR ASSESSMENT**

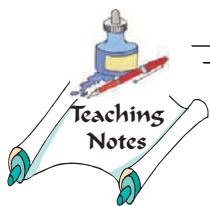

Empty box for suggestions for instruction.

**SUGGESTED LEARNING RESOURCES**

*Physics: Cinema Classics* videotape  
 Disk 1/Side A, Chapter 15, Relative Position: Who's Upside Down?  
 Chapter 16, Relative Motion: Who's Moving?;  
 Chapter 17, Relative Motion: Carts on a Table  
 Chapter 54, Boat and River

*Interactive Physics* software

BLM 3-3: Relative Velocity Vectors, McGraw-Hill Ryerson, 2003

BLM 2-1: Vector Components; BLM 2-2: Vector Addition by Components; BLM 3-1: Vectors in Two Dimensions; BLM 7-1: Relative Motion Problems, *Physics: Concepts and Connections*, Irwin Publishing Ltd., 2003

Investigation 3-B: Go with the Flow, *Physics 12*, McGraw-Hill Ryerson, 2003



## NOTES



---

## TOPIC 1.2: DYNAMICS

- S4P-1-4 Solve vector problems for objects in equilibrium.
- S4P-1-5 Calculate the forces acting on an object resting on an inclined plane.  
Include: normal force, friction, components of the gravitational force ( $mg$ )
- S4P-1-6 Calculate the components of  $\vec{F}_{\text{gravity}}$  exerted on an object resting on an inclined plane.
- S4P-1-7 Solve problems with  $\vec{F}_{\text{friction}}$  for objects on a horizontal surface and on an inclined plane.  
Include: coefficient of friction
- S4P-1-8 Solve problems using  $\vec{F}_{\text{net}} = m\vec{a}$  where  $\vec{F}_{\text{net}} = \vec{F}_{\text{applied}} + \vec{F}_{\text{friction}}$  and using kinematics equations from above.  
Include:  $\vec{F}_{\text{applied}}$  at an angle to horizontal motion; combined mass systems;  $\vec{F}_{\text{applied}}$  on an inclined plane; forces acting at various angles on a body
- S4P-1-9 Perform an experiment to investigate forces acting on an object.
-

**GENERAL LEARNING OUTCOME CONNECTION**

Students will...

Demonstrate appropriate scientific inquiry skills when seeking answers to questions (GLO C2)

**SPECIFIC LEARNING OUTCOME**

**S4P-1-4: Solve vector problems for objects in equilibrium.**



**SUGGESTIONS FOR INSTRUCTION**

**Entry Level Knowledge**

In Senior 3 Physics, vector problems were collinear and at right angles. Students also prepared free-body diagrams for forces acting on an object.

**Class Discussion**

Students solve problems for objects in equilibrium using vector components. See the illustrative example below.

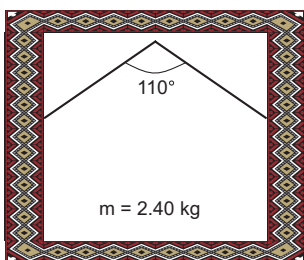

Diagram 1

**Problem:** Calculate the tension in the wire that is supporting the picture as illustrated.

*Solution:*

Step 1. Calculate the weight of the object.

$$\begin{aligned} \vec{F} &= m \vec{g} = (2.40 \text{ kg})(9.8 \text{ N/kg}) \\ &= 23.5 \text{ N [downwards]} \end{aligned}$$

Step 2. The total upward force equals the total downward force.

$$\vec{F}_{\text{upward}} = \vec{F}_g$$

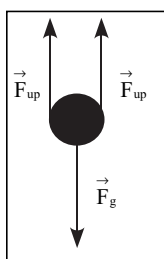

Diagram 2

Step 3. Since there are two support wires,

$$\vec{F}_{\text{upward}} = \vec{F}_g / 2 = 23.5 \text{ N} / 2 = 11.75 \text{ N [up]}$$

in each support wire.

Step 4. Bisect the angle  $\theta = 55^\circ$  and draw a vector diagram showing the components of the force and the resultant force.

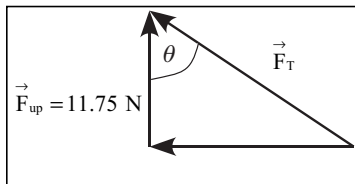

Diagram 3

Step 5. Solve for the hypotenuse that is the tension in the wire.

$$\begin{aligned} \cos 55^\circ &= 11.75 \text{ N} / \vec{F}_T \\ \vec{F}_T &= 11.75 \text{ N} / \cos 55^\circ = \\ &11.75 \text{ N} / 0.574 = 20.5 \text{ N} \end{aligned}$$



**SKILLS AND ATTITUDES OUTCOMES**

**S4P-0-2a:** Select and use appropriate visual, numeric, graphical, and symbolic modes of representation to identify and represent relationships.

**S4P-0-2h:** Analyze problems using vectors.  
Include: Adding and subtracting vectors in straight lines, at right angles, and at non-orthogonal angles

**GENERAL LEARNING OUTCOME CONNECTION**

*Students will...*

Understand the properties and structures of matter as well as various common manifestations and applications of the actions and interactions of matter (GLO D3)

**SUGGESTIONS FOR INSTRUCTION**

**SUGGESTIONS FOR ASSESSMENT**

**Teacher Demonstration**

Suspend a pair of spring scales to support a weight (1 kg). Show that as the supporting angle increases, the tension also increases.

**Laboratory Activity**

Use a laboratory activity to measure the forces on an object in equilibrium.

**Visual Display**

Students design and build a mobile that illustrates the concept of static equilibrium. This could be a decorative mobile that would amuse infants.

**Pencil-and-Paper Task**

Students work on equilibrium problems.

**SUGGESTED LEARNING RESOURCES**

BLM 17-1: Balancing Forces, *Physics: Concepts and Connections*, Irwin Publishing Ltd., 2003

Lab 7.1: Equilibrium and Forces, *Physics: Concepts and Connections*, Irwin Publishing Ltd., 2003

Quick Lab: Maintaining Equilibrium, p. 468, *Physics 12*, McGraw-Hill Ryerson, 2003





**GENERAL LEARNING OUTCOME CONNECTION**

*Students will...*

Demonstrate appropriate scientific inquiry skills when seeking answers to questions (GLO C2)

**SPECIFIC LEARNING OUTCOMES**



**S4P-1-5: Calculate the forces acting on an object resting on an inclined plane.**

Include: normal force, friction, components of the gravitational force (mg)

**S4P-1-6: Calculate the components of  $\vec{F}_{\text{gravity}}$  exerted on an object resting on an inclined plane.**

**SUGGESTIONS FOR INSTRUCTION**

**Notes to the Teacher**

The vector nature of force is now being extended to forces on an inclined plane.

**Class Discussion**

Illustrate how the force of gravity ( $\vec{F}_g$ ) is broken down into components. One component is parallel to the surface of the inclined plane ( $\vec{F}_{\parallel}$ ) and the other component force is perpendicular to the surface of the inclined plane ( $\vec{F}_{\perp}$ ).

The angle of the plane from horizontal equals the angle closest to the object in the triangle with the components.

$$\sin\theta = \frac{\vec{F}_{\parallel}}{\vec{F}_g}$$

$$\cos\theta = \frac{\vec{F}_{\perp}}{\vec{F}_g}$$

Note:  $\vec{F}_N = \vec{F}_{\parallel}$ , but  $\vec{F}_N$  is opposite in direction. Be sure to include the coordinate system in your diagram as this requires the student to draw the component force vectors in the proper orientation to the object's motion.

Provide several examples for the students to solve for component forces on an inclined plane.



**SKILLS AND ATTITUDES OUTCOME**

**S4P-0-2h:** Analyze problems using vectors.  
 Include: Adding and subtracting vectors in straight lines, at right angles, and at non-orthogonal angles

**GENERAL LEARNING OUTCOMES CONNECTION**

*Students will...*

Understand how stability, motion, forces, and energy transfers and transformations play a role in a wide range of natural and constructed contexts (GLO D4)

Recognize that characteristics of materials and systems can remain constant or change over time, and describe the conditions and processes involved (GLO E3)

**SUGGESTIONS FOR INSTRUCTION**

**SUGGESTIONS FOR ASSESSMENT**

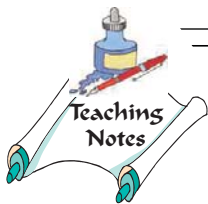

A large empty rectangular box for writing teaching notes.

**Visual Display**

Students use diagrams to show how the components of  $\vec{F}_g$  change with different angles of inclination, like  $0^\circ$ ,  $25^\circ$ ,  $50^\circ$ ,  $75^\circ$ , and  $90^\circ$ .

**Pencil-and-Paper Task**

Solve problems for components:

- determine the components of  $\vec{F}_g$
- determine the normal force
- determine the force of friction
- determine the  $\vec{F}_{net}$  on an inclined plane

**SUGGESTED LEARNING RESOURCES**

BLM 21-2: Sliding Friction, *Physics: Concepts and Connections*, Irwin Publishing Ltd., 2003

Lab 5.1: Kinetic Friction, p. 190, *Physics: Concepts and Connections*, Irwin Publishing Ltd., 2003

Lab 5.2: Static Friction, p. 191, *Physics: Concepts and Connections*, Irwin Publishing Ltd., 2003



**GENERAL LEARNING OUTCOME CONNECTION**

*Students will...*

Demonstrate appropriate scientific inquiry skills when seeking answers to questions (GLO C2)

**SPECIFIC LEARNING OUTCOMES**



**S4P-1-7: Solve problems with  $\vec{F}_{\text{friction}}$  for objects on a horizontal surface and on an inclined plane.**

Include: coefficient of friction

**S4P-1-8: Solve problems using  $\vec{F}_{\text{net}} = m\vec{a}$  where  $\vec{F}_{\text{net}} = \vec{F}_{\text{applied}} + \vec{F}_{\text{friction}}$  and using kinematics equations from S4P-1-1.**

Include:  $\vec{F}_{\text{applied}}$  at an angle to horizontal motion; combined mass systems;

$\vec{F}_{\text{applied}}$  on an inclined plane; forces acting at various angles on a body

**SUGGESTIONS FOR INSTRUCTION**

**Entry Level Knowledge**

In Senior 3 Physics, students studied the forces acting on an object on an inclined plane in a qualitative manner. Students are familiar with the coefficient of friction and the calculation of frictional force and normal force.

**Notes to the Teacher**

Students should solve various situations for objects on inclined planes. For example:



A person in a wheelchair is travelling up an inclined sidewalk. The coefficient of friction is 0.11 and the mass of the person and the wheelchair is 65.0 kg. The degree of incline is 7°. Can the person rest comfortably on the inclined sidewalk, or will this person's wheelchair roll down the incline? Calculate the acceleration if the person cannot rest comfortably on the inclined sidewalk. Support your answer mathematically.

**Collaborative Teamwork**

Students write a memo to a construction firm, describing the above problem. Students also explain the effect a heavier person, type of material, or angle of the ramp would have on the acceleration of the wheelchair.

**Notes to the Teacher**

Encourage students to identify all the forces acting on an object in the following situations. These forces should be labelled. See Appendix 1.4 for illustrative examples.

- $\vec{F}_{\text{applied}}$  at an angle to horizontal motion
- $\vec{F}_{\text{applied}}$  on an inclined plane
- combined mass systems
- forces acting at various angles on a body
- two forces acting horizontally, pulling an object along the horizontal plane

**SKILLS AND ATTITUDES OUTCOMES**

**S4P-0-2a:** Select and use appropriate visual, numeric, graphical, and symbolic modes of representation to identify and represent relationships.

**S4P-0-2h:** Analyze problems using vectors.  
Include: Adding and subtracting vectors in straight lines, at right angles, and at non-orthogonal angles

**GENERAL LEARNING OUTCOME CONNECTION**

*Students will...*

Understand how stability, motion, forces, and energy transfers and transformations play a role in a wide range of natural and constructed contexts (GLO D4)

**SUGGESTIONS FOR INSTRUCTION**

**SUGGESTIONS FOR ASSESSMENT**

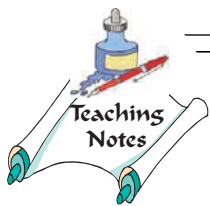

Empty box for teaching notes.

**Performance Assessment**

Students construct their own problems with answers and they exchange these questions with each other to aid in solving a variety of problems.

Students work in small groups and generate a series of problems with their solutions based on kinematics/dynamics equations. They then exchange their problem set with another group and solve the other group's problem set.

**Pencil-and-Paper Task**

Students work on a variety of problems such as:

- $\vec{F}_{\text{applied}}$  at an angle to horizontal motion
- $\vec{F}_{\text{applied}}$  on an inclined plane
- combined mass systems
- applied forces acting at various angles on a body (see Suggestions for Instruction)

**Research Report/Presentation**

Students prepare a report that discusses how kinematics concepts are applied to real-life situations. For example, how does one move a heavy barrel up an incline? How do piano movers raise a piano into the moving van? How are heavy objects moved from one level to a lower/higher level?



GENERAL LEARNING OUTCOME CONNECTION	SPECIFIC LEARNING OUTCOME	SKILLS AND ATTITUDES OUTCOMES
<p><i>Students will...</i></p> <p>Recognize that scientific knowledge is based on evidence, models, and explanations, and evolves as new evidence appears and new conceptualizations develop (GLO A2)</p>	<p><b>S4P-1-9: Perform an experiment to investigate forces acting on an object.</b></p>	<p><b>S4P-0-2b:</b> Propose problems, state hypotheses, and plan, implement, adapt, or extend procedures to carry out an investigation where required.</p> <p><b>S4P-0-2d:</b> Estimate and measure accurately using SI units.</p>

### SUGGESTIONS FOR INSTRUCTION

#### Notes to the Teacher

See recommended textbooks for suitable labs.

#### SUGGESTIONS FOR ASSESSMENT

##### Laboratory Report

Students collect, organize, and graphically illustrate data obtained and submit a lab report using a pre-established format.

##### Visual Displays

Students design and construct a model of, or a portion of, an amusement park ride.

Students use a free-body diagram and the appropriate algebra to describe the forces and accelerations involved in the ride.

##### Strategies for Connecting the Dynamics Outcomes Together

Students complete a Three-Point Approach for each of the following terms:

##### Dynamics

inertia	laws of inertia
inertial frame of reference	force
unbalanced force	normal force
action-reaction forces	force of gravity
weight	dynamics
force of friction	static friction
kinetic friction	applied force
coefficient of friction	net force
inclined plane	



**SKILLS AND ATTITUDES OUTCOMES**

**S4P-0-2e:** Evaluate the relevance, reliability, and adequacy of data and data-collection methods.

Include: discrepancies in data and sources of error

**S4P-0-2f:** Record, organize, and display data using an appropriate format.

Include: labelled diagrams, tables, graphs

**S4P-0-4a:** Demonstrate work habits that ensure personal safety, the safety of others, and consideration of the environment.

**GENERAL LEARNING OUTCOME CONNECTION**

*Students will...*

Demonstrate curiosity, skepticism, creativity, open-mindedness, accuracy, precision, honesty, and persistence, and appreciate their importance as scientific and technological habits of mind (GLO C5)

**SUGGESTIONS FOR ASSESSMENT**

**Journal Entries**

1. On the Compare and Contrast frame, compare and contrast the force of kinetic friction and the force of static friction.
2. On the Concept Relationship frame, compare and contrast gravitational mass and inertial mass.
3. Prepare a concept map relating these key concepts:

kinematics  
the Second Law  
normal force  
net force  
inclined plane  
coefficient of friction

dynamics  
force of friction  
applied force  
force of gravity  
free body diagram

**SUGGESTIONS FOR ASSESSMENT**

**Concept Questions: Newton's Laws of Motion**

Using the appropriate law, explain the following.

1. A bullet is fired from a rifle. The rifle recoils.
2. A Judo expert attempts to break 10 boards piled on top of each other by striking them with one blow of his hand. In the process, he breaks a bone in his hand.
3. The stationary car in which a passenger sits is struck from the rear by a second car. The passenger suffers whiplash.
4. A boy throws an egg as hard as he can at a blanket held by two people. The egg is caught in the blanket without being broken.
5. A curling rock slides along the ice and slowly comes to a stop.
6. A rock is dropped from a bridge and accelerates towards the Earth. The rock exerts a force on the Earth. We do not notice the Earth accelerating towards the rock.

**SUGGESTED LEARNING RESOURCES**

Quick Lab: The Slippery Slope, p. 192, *Physics 12*, McGraw-Hill Ryerson, 2003

Investigation 10-A: Atwood's Machine, p. 480, *Physics 12*, McGraw-Hill Ryerson, 2003

Lab 6.2: Amusement Park Physics, *Physics: Concepts and Connections*, Irwin Publishing Ltd., 2003



## NOTES



---

## **TOPIC 1.3: MOMENTUM**

- S4P-1-10 Derive the impulse-momentum equation from Newton's second law.
- S4P-1-11 Determine impulse from the area under a force-time graph.  
Include: constant positive and negative force, uniformly changing force
- S4P-1-12 Experiment to illustrate the Law of Conservation of Momentum in one and two dimensions.
- S4P-1-13 Solve problems using the impulse-momentum equation and Law of Conservation of Momentum.
- S4P-1-14 Relate the impulse-momentum equation to real-life situations.  
*Examples: hitting a ball, catching a ball*
-



**GENERAL LEARNING OUTCOME CONNECTION**

*Students will...*

Recognize that scientific knowledge is based on evidence, models, and explanations, and evolves as new evidence appears and new conceptualizations develop (GLO A2)

**SPECIFIC LEARNING OUTCOME**

**S4P-1-10: Derive the impulse-momentum equation from Newton’s second law.**



**SUGGESTIONS FOR INSTRUCTION**

**Entry Level Knowledge**

Students have studied momentum qualitatively in Senior 2 Science and are familiar with Newton’s second law.

**Prior Knowledge Activity**

Now is a good time to use the SYSTH Activity: KWL Plus, p. 9.24, to access students’ prior knowledge.

**Notes to the Teacher**

Relate impulse-momentum to Newton’s second law with the following derivation.

$$\vec{F} = m\vec{a} = m \frac{\Delta \vec{v}}{\Delta t}$$

$$\vec{F} \Delta t = m \Delta \vec{v}$$

Newton stated his three laws of motion in his book *Principia Mathematica*. Although Newton’s second law is given as  $F_{\text{net}} = ma$  in textbooks, Newton actually stated that “the change of motion is proportional to the motive force impressed.” By the word “motion,” Newton meant the quantity that today we call “momentum.” Thus, in his original statement, “the motive force” acts to change the momentum of a body.

**Teacher Demonstrations**

Blow a dry ink marker through a short tube and then do it again through a longer tube. The force with which the marker is blown should be the same for both the small tube and the longer tube. Students should note that as  $\Delta t$  is increased, then  $m\Delta v$  will increase.

Accelerate a cart with one elastic, then replace with two elastics. Elastics must be stretched the same amount. Students should note the differences in the change in momentum of the two cases (time interval is the same for both cases).

A student standing on a skateboard throws a massive object (medicine ball) at another student, standing on the floor, who catches the object. Students can visualize the recoil velocity of the student on the skateboard.



**SKILLS AND ATTITUDES OUTCOMES**

**S4P-0-2c:** Formulate operational definitions of major variables or concepts.

**S4P-0-2g:** Develop mathematical models involving linear, power, and/or inverse relationships among variables.

**GENERAL LEARNING OUTCOME CONNECTION**

*Students will...*

Describe and appreciate how the natural and constructed worlds are made up of systems and how interactions take place within and among these systems (GLO E2)

**SUGGESTIONS FOR INSTRUCTION**

**SUGGESTIONS FOR ASSESSMENT**

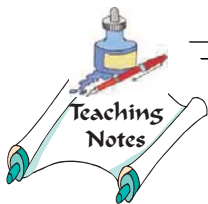

**Pencil-and-Paper Task**

Students derive the impulse-momentum equation.



**GENERAL LEARNING OUTCOME CONNECTION**

Students will...

Demonstrate appropriate scientific inquiry skills when seeking answers to questions (GLO C2)

**SPECIFIC LEARNING OUTCOME**

**S4P-1-11: Determine impulse from the area under a force-time graph.**

Include: constant positive and negative force, uniformly changing force



**SUGGESTIONS FOR INSTRUCTION**

**Entry Level Knowledge**

The techniques for determining the impulse from the area under a force-time graph are similar to the techniques used for determining the displacement from the area under a velocity-time graph. Students have experienced calculating areas under a curve with various shapes; i.e., rectangular shape, triangular shape, trapezoidal shape.

**Class Discussion**

Students analyze force-time graphs to determine the impulse. See diagram below:

- Area A represents positive area (constant force)
- Area B represents negative area (constant force)
- Area C represents positive area (triangle) (constantly changing force)
- Area D represents positive area (trapezoid) (constantly changing force)

**Student Activity**

Compare/contrast (SYSTH) impulse and change in momentum.

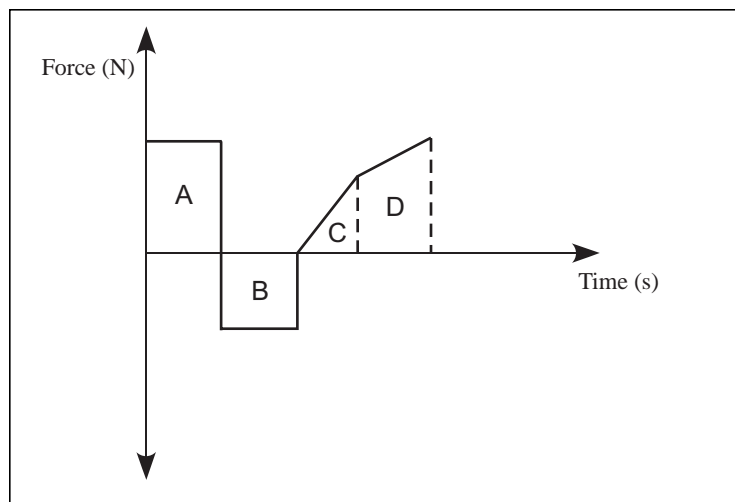

Force-Time Graph



**SKILLS AND ATTITUDES OUTCOME**

**S4P-0-2a:** Select and use appropriate visual, numeric, graphical, and symbolic modes of representation to identify and represent relationships.

**GENERAL LEARNING OUTCOME CONNECTION**

*Students will...*

Understand how stability, motion, forces, and energy transfers and transformations play a role in a wide range of natural and constructed contexts (GLO D4)

**SUGGESTIONS FOR INSTRUCTION**

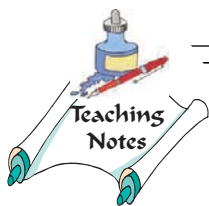

A large, empty rectangular box intended for instructional suggestions, located below the 'SUGGESTIONS FOR INSTRUCTION' header.

**SUGGESTIONS FOR ASSESSMENT**

**Pencil-and-Paper Task**

Students calculate impulse or change in momentum from different graphs to determine the impulse.

**SUGGESTED LEARNING RESOURCES**

BLM 29-1: F-t Graphs and Impulse, *Physics: Concepts and Connections*, Irwin Publishing Ltd., 2003



GENERAL LEARNING OUTCOME CONNECTION	SPECIFIC LEARNING OUTCOME	SKILLS AND ATTITUDES OUTCOMES
<p><i>Students will...</i></p> <p>Demonstrate curiosity, skepticism, creativity, open-mindedness, accuracy, precision, honesty, and persistence, and appreciate their importance as scientific and technological habits of mind (GLO C5)</p>	<p><b>S4P-1-12: Experiment to illustrate the Law of Conservation of Momentum in one and two dimensions.</b></p>	<p><b>S4P-0-2b:</b> Propose problems, state hypotheses, and plan, implement, adapt, or extend procedures to carry out an investigation where required.</p> <p><b>S4P-0-2d:</b> Estimate and measure accurately using SI units.</p>

### SUGGESTIONS FOR INSTRUCTION

To introduce the concept of the Law of Conservation of Momentum, students demonstrate the following:

A student standing on a skateboard throws a massive object (medicine ball) at another student, standing on another skateboard, who catches the object.

Students visualize the effects of throwing the massive object on both boarders. The idea of an isolated system is demonstrated by this action. A system is made up of two or more objects. An isolated system is one that is not acted upon by a net external force.

Students videotape a collision and analyze the tape (use an air track, a dynamic cart on a level table, a billiard table, curling rink, or ball bearings on a smooth track). Assume that friction is negligible and the time interval is of short duration.

Use *Interactive Physics* simulation software to simulate collisions between objects in one dimension and two dimensions. (See Appendix 1.6 for sample activity.)

**STSE:** Police Analysis of Car Accidents (*Physics: Concepts and Connections*, p. 302, Irwin Publishing Ltd., 2003)



**SKILLS AND ATTITUDES OUTCOMES**

**S4P-0-2e:** Evaluate the relevance, reliability, and adequacy of data and data-collection methods.

Include: discrepancies in data and sources of error

**S4P-0-2f:** Record, organize, and display data using an appropriate format.

Include: labelled diagrams, tables, graphs

**S4P-0-2h:** Analyze problems using vectors.

Include: Adding and subtracting vectors in straight lines, at right angles, and at non-orthogonal angles

**S4P-0-4a:** Demonstrate work habits that ensure personal safety, the safety of others, and consideration of the environment.

**GENERAL LEARNING OUTCOME CONNECTION**

*Students will...*

Describe and appreciate how the natural and constructed worlds are made up of systems and how interactions take place within and among these systems (GLO E2)

**SUGGESTIONS FOR INSTRUCTION**

**SUGGESTIONS FOR ASSESSMENT**

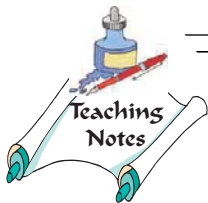

**Laboratory Report**

Provide a written lab report with complete analysis.

**SUGGESTED LEARNING RESOURCES**

Lab 8.1: Conservation of Linear Momentum, p. 314, *Physics: Concepts and Connections*, Irwin Publishing Ltd., 2003

Physics Lab: The Explosion, p. 213, *Physics: Principles and Problems*, Glencoe, 2002

Lab 8.2: Linear Momentum in One Dimension: Dynamic Laboratory Carts, pp. 315–316, *Physics: Concepts and Connections*, Irwin Publishing Ltd., 2003

Lab 8.3: Linear Momentum in Two Dimensions: Ramp and Ball, p. 317, *Physics: Concepts and Connections*, Irwin Publishing Ltd., 2003

Investigation 10-B: Collisions in Two Dimensions, p. 516, *Physics 12*, McGraw-Hill Ryerson, 2003



**GENERAL LEARNING OUTCOME CONNECTION**

*Students will...*

Recognize both the power and limitations of science as a way of answering questions about the world and explaining natural phenomena (GLO A1)

**SPECIFIC LEARNING OUTCOME**

**S4P-1-13: Solve problems using the impulse-momentum equation and the Law of Conservation of Momentum.**



**SUGGESTIONS FOR INSTRUCTION**

Provide students with a variety of situations to problem solve. For example, students analyze a force-time graph to calculate the impulse, the change in momentum, the change in velocity, the final velocity, and the average force.

Other examples are: bullet being fired from a rifle, bullet getting embedded in a block of wood, ballistic pendulum, hitting a golf ball or tennis ball, or the recoil of an astronaut.

For the Law of Conservation of Momentum in one dimension and two dimensions, the approach to solving the problems follows this sequence.

- Establish a coordinate system.
- Show the initial and final states.
- Draw and label the two objects and their velocities.
- Substitute into the equation below and calculate the momentum of each individual object.

$$\begin{aligned} \vec{p}_{\text{total initial}} &= \vec{p}_{\text{total final}} \\ \vec{p}_{1\text{initial}} + \vec{p}_{2\text{initial}} &= \vec{p}_{1\text{final}} + \vec{p}_{2\text{final}} \\ m_1 \vec{v}_{1\text{initial}} + m_2 \vec{v}_{2\text{initial}} &= m_1 \vec{v}_{1\text{final}} + m_2 \vec{v}_{2\text{final}} \end{aligned}$$

Draw a vector diagram for the total momentum and calculate the missing momentum or velocity.

Illustrative examples are included in Appendix 1.5 and Appendix 1.6.



**SKILLS AND ATTITUDES OUTCOMES**

**S4P-0-2g:** Develop mathematical models involving linear, power, and/or inverse relationships among variables.

**S4P-0-2h:** Analyze problems using vectors.

Include: Adding and subtracting vectors in straight lines, at right angles, and at non-orthogonal angles

**GENERAL LEARNING OUTCOME CONNECTION**

*Students will...*

Recognize that characteristics of materials and systems can remain constant or change over time, and describe the conditions and processes involved (GLO E3)

**SUGGESTIONS FOR INSTRUCTION**

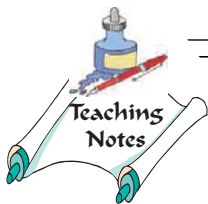

*(This area is intentionally left blank for instructional suggestions.)*

**SUGGESTED LEARNING RESOURCES**

BLM 25-1: Elastic and Inelastic Collisions in Two Dimensions, *Physics: Concepts and Connections*, Irwin Publishing Ltd., 2003

BLM 31-1: Momentum and Simple Collisions, *Physics: Concepts and Connections*, Irwin Publishing Ltd., 2003

**SUGGESTIONS FOR ASSESSMENT**

**Science Journal Entries**

Students write process notes to describe their step-by-step, problem-solving approach to the Law of Conservation of Momentum problems.

**Visual Displays**

Students create a concept map showing all variables involved and how they are linked to solve conservation of momentum questions.

**Pencil-and-Paper Tasks**

Students solve a variety of problems for momentum:

1. one dimensional
2. two dimensional

For complex problems, students break the problem down to solve for the following components:

1. momentum
2. change in momentum for one object
3. total initial momentum for a system of two objects
4. total final momentum for a system of two objects
5. impulse applied
6. average force
7. final velocities for a system of two objects and as an extension
8. describe the motion of the centre of mass





**GENERAL LEARNING OUTCOME CONNECTION**

*Students will...*

Recognize that science and technology interact with and advance one another (GLO A5)

Evaluate, from a scientific perspective, information and ideas encountered during investigations and in daily life (GLO C8)

**SPECIFIC LEARNING OUTCOME**

**S4P-1-14: Relate the impulse-momentum equation to real-life situations.**

*Examples: hitting a ball, catching a ball*



**SUGGESTIONS FOR INSTRUCTION**

**Entry Level Knowledge**

Students are familiar with the application of momentum in car crashes from Senior 2 Science. They are aware of the first collision (car to car) and the second collision (driver to steering wheel/air bag).

**Notes to the Teacher**

In real-life examples, forces often vary during a collision between objects. Attempting to measure such a change in force is very difficult. Consequently, the average force of an interaction for some interval is generally determined by analyzing the motion.

Hitting a ball involves exerting a force with one object, a bat or racquet, on another object, the ball. To increase the final velocity of the struck object, the impulse applied must be increased. Since impulse is the product of force and time, we can increase the force by hitting harder (build up your muscles!) or by lengthening the time interval during which the object is struck. Athletes train to increase their power and they are coached to practise a correct technique of hitting objects by increasing the time interval of contact (in the coach's terms, "follow through"). Once maximum force is achieved, the technique focusses on lengthening the time interval for contact between objects.

Students' prior knowledge from Senior 2 Science includes analysis of how an air bag is able to stop a person during a very short time interval. This would require tremendous forces to achieve a change in momentum. The air bag lengthens the stopping distance and the time interval to lessen the force. Catching a ball requires the same cushioning effect as an air bag. While catching a ball, the person moves his or her hands in the same direction as the ball is moving. This lengthens the stopping time interval and lessens the force directed on the hands.

Students can research car accidents with regards to the first collision (two vehicles hitting) and also the second collision (driver/passenger within vehicle).

In Senior 4 Physics, the mathematical model is a point of emphasis so any analysis should contain the calculations involved for the driver/passenger's stopping during the second collision.



**SKILLS AND ATTITUDES OUTCOMES**

**S4P-0-3b:** Describe examples of how technology has evolved in response to scientific advances, and how scientific knowledge has evolved as the result of new innovations in technology.

**S4P-0-4b:** Work co-operatively with a group to identify prior knowledge, initiate and exchange ideas, propose problems and their solution, and carry out investigations.

**GENERAL LEARNING OUTCOME CONNECTION**

*Students will...*

Demonstrate a knowledge of, and personal consideration for, a range of possible science- and technology-related interests, hobbies, and careers (GLO B4)

**SUGGESTIONS FOR INSTRUCTION**

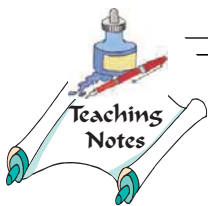

A large empty rectangular box for writing teaching notes.

**SUGGESTIONS FOR ASSESSMENT**

**Science Journal Entries**

Students prepare two lists of events in their journals. One list includes events in which the momentum of objects changes over a short  $\Delta t$ . The other list includes events that have a significant longer  $\Delta t$ . Students describe the consequences of the magnitude of each event's  $\Delta t$ .

**Research Report/Presentation**

Students prepare a report on how the impulse-momentum theorem can be illustrated with examples from sports. Students describe the circumstances requiring long impulse times and those requiring short impulse times. How does impulse time affect what the athlete does or what equipment the athlete uses in the sport?

Students investigate the safety aspects of bike helmets. Are helmets still safe after the helmet has sustained an impact?

**SUGGESTED LEARNING RESOURCES**

STSE Interrelationships, pp. 302–303, *Physics: Concepts and Connections*, Irwin Publishing Ltd., 2003



NOTES



---

## ***TOPIC 1.4: PROJECTILE MOTION***

- S4P-1-15 Solve simple free-fall problems using the special equations for constant acceleration.  
Include: horizontal and vertical components of motion of the curved path of a projectile (without air resistance)
- S4P-1-16 Draw free-body diagrams for a projectile at various points along its path (with and without air resistance).
- S4P-1-17 Calculate the horizontal and vertical components with respect to velocity and position of a projectile at various points along its path.
- S4P-1-18 Solve problems for projectiles launched horizontally and at various angles to the horizontal to calculate maximum height, range, and overall time of flight of the projectile.
-

**GENERAL LEARNING OUTCOME CONNECTION**

*Students will...*

Recognize both the power and limitations of science as a way of answering questions about the world and explaining natural phenomena (GLO A1)

**SPECIFIC LEARNING OUTCOME**

**S4P-1-15: Solve simple free-fall problems using the special equations for constant acceleration.**

Include: horizontal and vertical components of motion of the curved path of a projectile (with or without air resistance)



**SUGGESTIONS FOR INSTRUCTION**

**Entry Level Knowledge**

The special equations for constant acceleration are covered in Topic 1 and students are familiar with free fall from Senior 3 Physics.

**Notes to the Teacher**

Solve various problems using the derived kinematic equations, given the  $a = g = -9.8 \text{ m/s}^2$ . The problems should include when the initial velocity is zero (dropped object), the initial velocity is positive, and the initial velocity is negative. A common student difficulty is recognizing that an object at its maximum height still has an acceleration of  $-9.8 \text{ m/s}^2$  although its instantaneous velocity is zero.

Another student difficulty is when an object is in a system that is moving at a constant velocity (i.e., rising) and the object is released. Students tend to believe the initial velocity of the object is zero, but it actually is the velocity of the moving system. Additionally, when an object is thrown upward and returns to its original position, the displacement of the object would be zero when applying the kinematics equations.

**Collaborative Teamwork**

Students are given a simple free-fall problem to resolve in a group and then present the solution to the rest of the class.

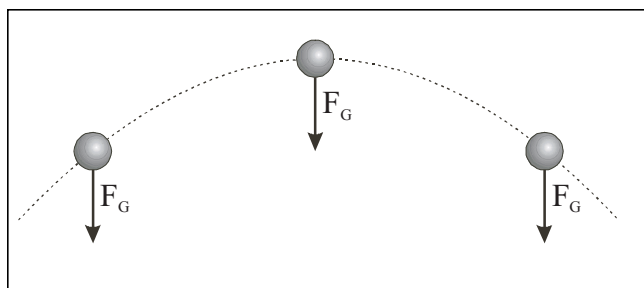

**The Force of Gravity Is Always Constant**



**SKILLS AND ATTITUDES OUTCOME**

**S4P-0-2g:** Develop mathematical models involving linear, power, and/or inverse relationships among variables.

**GENERAL LEARNING OUTCOME CONNECTION**

*Students will...*

Recognize that characteristics of materials and systems can remain constant or change over time, and describe the conditions and processes involved (GLO E3)

**SUGGESTIONS FOR INSTRUCTION**

**SUGGESTIONS FOR ASSESSMENT**

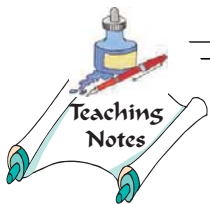

A large, empty rectangular box intended for handwritten or typed notes under the "SUGGESTIONS FOR INSTRUCTION" header.

**Pencil-and-Paper Tasks**

Students solve problems for free fall using the special equations of motion.



**GENERAL LEARNING OUTCOME CONNECTION**

Students will...

Recognize that scientific knowledge is based on evidence, models, and explanations, and evolves as new evidence appears and new conceptualizations develop (GLO A2)

**SPECIFIC LEARNING OUTCOMES**



**S4P-1-16: Draw free-body diagrams for a projectile at various points along its path (with or without air resistance).**

**S4P-1-17: Calculate the horizontal and vertical components with respect to velocity and position of a projectile at various points along its path.**

**SUGGESTIONS FOR INSTRUCTION**

**Entry Level Knowledge**

Vector components are addressed in the Topic 1.2 (Dynamics) and simple free-body diagrams are covered in Senior 3 Physics.

**Notes to the Teacher**

Students must be aware that the horizontal and vertical motions are independent of each other. To reinforce these concepts, it is useful to draw free-body diagrams. The horizontal motion is a uniform (constant) motion and the vertical motion is a uniformly accelerated motion ( $a = -9.8 \text{ m/s}^2$ ). The net force ( $F_g$ ) acting on the projectile is constant (neglecting air resistance).

If air resistance is taken into consideration, the frictional force will always be in the opposite direction to the velocity (tangential to the path). The frictional force will decrease the horizontal as well as the vertical components of velocity. The resulting path will be asymmetrical. Students should only analyze this type of projection qualitatively, not quantitatively.

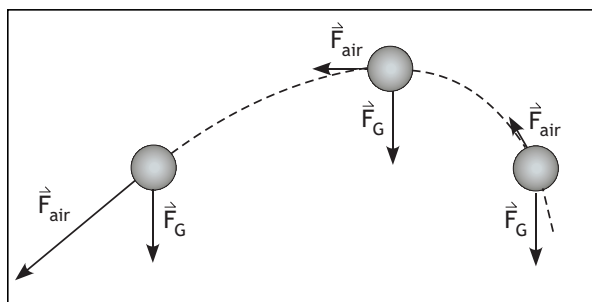

Projectile with Air Resistance

**Class Activities**

Review qualitatively, with the aid of diagrams, the horizontal and vertical velocities, and acceleration. Observe a projectile with a stroboscope and record on a video camera to analyze with computer software or VCR. Show Vertical and Horizontal Motion from the videodisc *Physics: Cinema Classics*. This gives an excellent demonstration of the independence of these two motions.

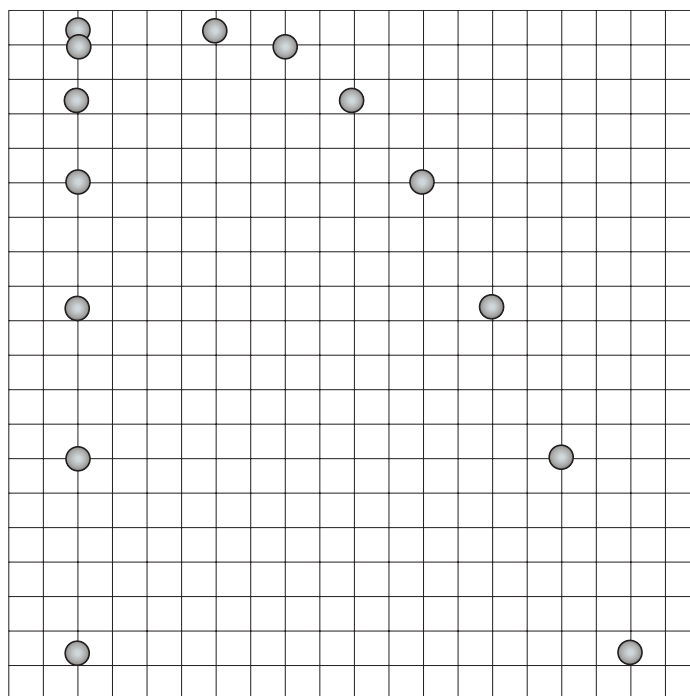

Strobe of free fall and projectile



**SKILLS AND ATTITUDES OUTCOME**

**S4P-0-2f:** Record, organize, and display data using an appropriate format.

Include: labelled diagrams, tables, graphs

**GENERAL LEARNING OUTCOME CONNECTION**

*Students will...*

Demonstrate appropriate scientific inquiry skills when seeking answers to questions (GLO C2)

Demonstrate appropriate problem-solving skills while seeking solutions to technological challenges (GLO C3)

**SUGGESTIONS FOR INSTRUCTION**

Students should be careful to differentiate between force and velocity vectors. A blackline master of the strobe photo is included in Appendix 1.7 for copying.

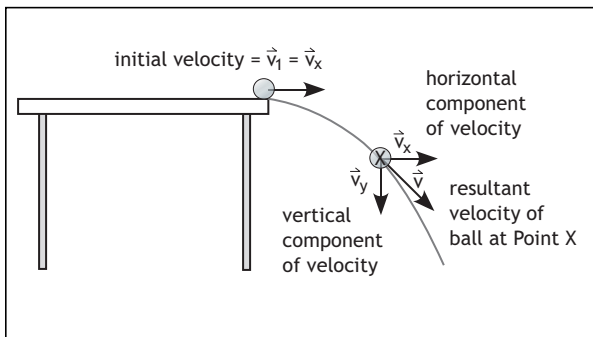

**SUGGESTIONS FOR ASSESSMENT**

**Pencil-and-Paper Tasks**

Draw free-body diagrams of a projectile at various points on its path, using vectors to represent the horizontal and vertical velocities.

Calculate the horizontal and vertical components of position and velocity.

Determine the net force, position, and velocity vectors.

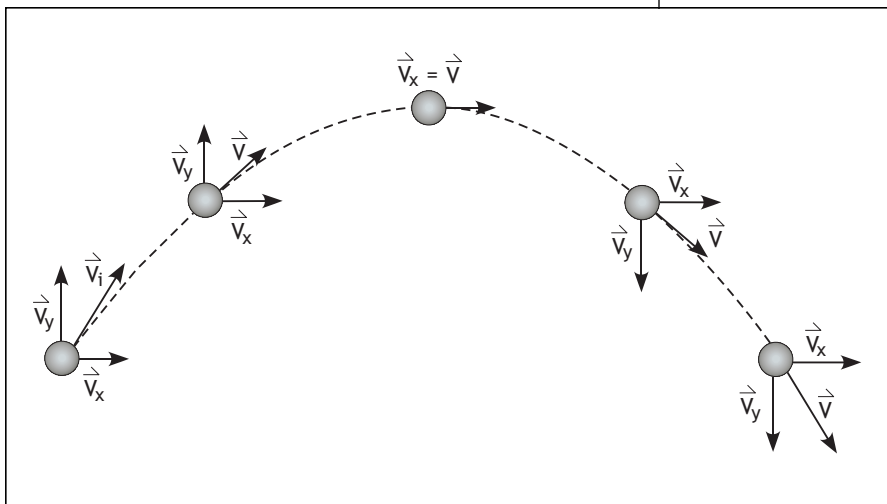



**GENERAL LEARNING OUTCOME CONNECTION**

*Students will...*

Recognize that scientific knowledge is based on evidence, models, and explanations, and evolves as new evidence appears and new conceptualizations develop (GLO A2)

**SPECIFIC LEARNING OUTCOMES**



**S4P-1-16: Draw free-body diagrams for a projectile at various points along its path (with or without air resistance).**

**S4P-1-17: Calculate the horizontal and vertical components with respect to velocity and position of a projectile at various points along its path.**

**SUGGESTIONS FOR INSTRUCTION**

**Demonstrations**

An air table, inclined at an angle, can demonstrate the motion of a projectile. A stream of water can also demonstrate trajectories associated with initial angles of launch.

Place two coins on the edge of a table, with one placed above the other (see diagram). Launch objects simultaneously off the edge of a table using a flexible ruler. The coin further out will have a greater velocity and therefore a greater range, but both coins will land on the floor at the same time.

Have students observe this demonstration visually and by listening to the sound of the ruler striking the coins and the coins striking the ground. Using the diagrams provided, students measure the horizontal and vertical displacement for each time interval. Students reach the conclusion that the horizontal velocity component is constant and the vertical component of velocity increases/decreases the same as an object in free-fall motion.

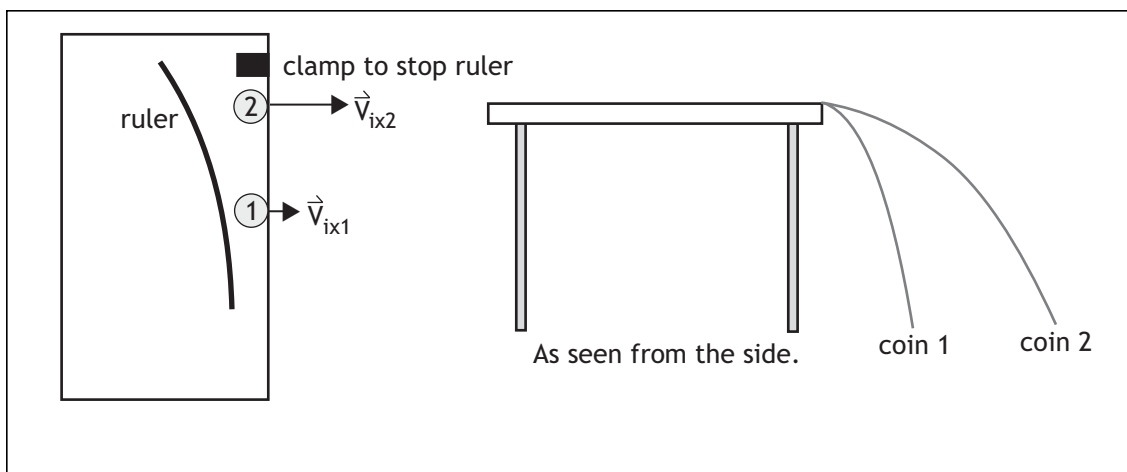

**SKILLS AND ATTITUDES OUTCOME**

**S4P-0-2f:** Record, organize, and display data using an appropriate format.

Include: labelled diagrams, tables, graphs

**GENERAL LEARNING OUTCOME CONNECTION**

*Students will...*

Demonstrate appropriate scientific inquiry skills when seeking answers to questions (GLO C2)

Demonstrate appropriate problem-solving skills while seeking solutions to technological challenges (GLO C3)

**SUGGESTIONS FOR INSTRUCTION**

**SUGGESTIONS FOR ASSESSMENT**

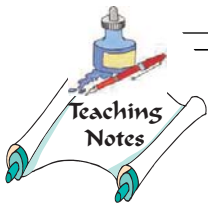

Large empty rectangular box for instructional suggestions.

Large empty rectangular box for assessment suggestions.



GENERAL LEARNING OUTCOME CONNECTION	SPECIFIC LEARNING OUTCOME	SKILLS AND ATTITUDES OUTCOMES
<p><i>Students will...</i></p> <p>Demonstrate appropriate critical thinking and decision-making skills when choosing a course of action based on scientific and technological information (GLO C4)</p>	<p><b>S4P-1-18: Solve problems for projectiles launched horizontally and at various angles to the horizontal to calculate maximum height, range, and overall time of flight of the projectile.</b></p>	<p><b>S4P-0-2b:</b> Propose problems, state hypotheses, and plan, implement, adapt, or extend procedures to carry out an investigation where required.</p> <p><b>S4P-0-2d:</b> Estimate and measure accurately using SI units.</p>

### SUGGESTIONS FOR INSTRUCTION

#### Entry Level Knowledge

Equations for constant acceleration are covered in Topic 1 and uniform motion is treated in both Senior 2 Science and Senior 3 Physics.

#### Notes to the Teacher

The calculations of the horizontal and vertical components should involve situations when the projectile is rising and when the projectile is on its way back down with respect to velocity and position. The velocity and position of a projectile coming to rest at the same height at which it was launched will be symmetrical with respect to the maximum height midpoint. The maximum range of a projectile will be obtained when launched at an angle of  $45^\circ$ . Any two complementary launch angles will have the same range, provided air resistance is ignored.

#### Class Activity

Illustrative examples with solutions are included in Appendix 1.7.

#### Laboratory Activities

Perform a lab of a projectile launched horizontally and/or at an angle (commonly referred to as a “monkey” or Gauss gun).

Construct and launch catapults (trebuchet or counterweight design).

#### Student Research/Report

Students research and report on the historical development of a catapult or trebuchet.



**SKILLS AND ATTITUDES OUTCOMES**

**S4P-0-2g:** Develop mathematical models involving linear, power, and/or inverse relationships among variables.

**S4P-0-2i:** Select and integrate information obtained from a variety of sources.

Include: print, electronic, specialists, or other resource people

**S4P-0-3b:** Describe examples of how technology has evolved in response to scientific advances, and how scientific knowledge has evolved as the result of new innovations in technology.

**S4P-0-3e:** Identify a problem, initiate research, and design a technological or other solution to address the problem.

**GENERAL LEARNING OUTCOME CONNECTION**

*Students will...*

Understand how stability, motion, forces, and energy transfers and transformations play a role in a wide range of natural and constructed contexts (GLO D4)

**SUGGESTIONS FOR INSTRUCTION**

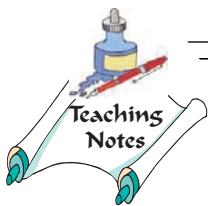

**SUGGESTIONS FOR ASSESSMENT**

**Pencil-and-Paper Tasks**

Students solve kinematics equations for projectile problems.

**Problem-Based Learning**

Catapult contest: Students use the design process to build a catapult or trebuchet to launch a marshmallow. Assessment is based on design, distance, and accuracy.

**SUGGESTED LEARNING RESOURCES**

Lab 3.1: Initial Velocity of a Projectile, p. 119, *Physics: Concepts and Connections*, Irwin Publishing Ltd., 2003

Lab 3.2: Projectile Motion, p. 120, *Physics: Concepts and Connections*, Irwin Publishing Ltd., 2003



## NOTES



---

## **TOPIC 1.5: CIRCULAR MOTION**

- S4P-1-19 Explain qualitatively why an object moving at constant speed in a circle is accelerating toward the centre of the circle.
- S4P-1-20 Discuss the centrifugal effects with respect to Newton's laws.
- S4P-1-21 Draw free-body diagrams of an object moving in uniform circular motion.
- S4P-1-22 Experiment to determine the mathematical relationship between period and frequency and one or more of the following: centripetal force, mass, and radius.
- S4P-1-23 Derive an equation for the constant speed and acceleration of an object moving in a circle

$$\left( \vec{v} = \frac{2\pi r}{T}, a = \frac{v^2}{R} \right)$$

- S4P-1-24 Solve problems for an object moving with a constant speed in a circle using

$$a = \frac{v^2}{R}, \vec{v} = \frac{2\pi r}{T}, \text{ and } \vec{F}_{\text{net}} = m\vec{a}.$$

---

**GENERAL LEARNING OUTCOME CONNECTION**

*Students will...*

Demonstrate appropriate scientific inquiry skills when seeking answers to questions (GLO C2)

**SPECIFIC LEARNING OUTCOME**

**S4P-1-19: Explain qualitatively why an object moving at a constant speed in a circle is accelerating toward the centre of the circle.**



**SUGGESTIONS FOR INSTRUCTION**

**Entry Level Knowledge**

Students should be familiar with the circumference of a circle, Newton’s Second Law, and uniform accelerated motion.

**Notes to the Teacher**

Uniform circular motion is the motion of an object moving at a constant speed in a circular path. The acceleration—centripetal acceleration—toward the centre of the circle can be explained using the definition of acceleration (rate of change of velocity) where the direction of the acceleration is the same as the direction of the change in velocity (see diagram). That is, since the net force is toward the centre, so is the acceleration.

**Classroom Activities**

Students build and use accelerometers to observe the effects of various forms of acceleration. These devices are often used when students investigate the physics of amusement park rides.

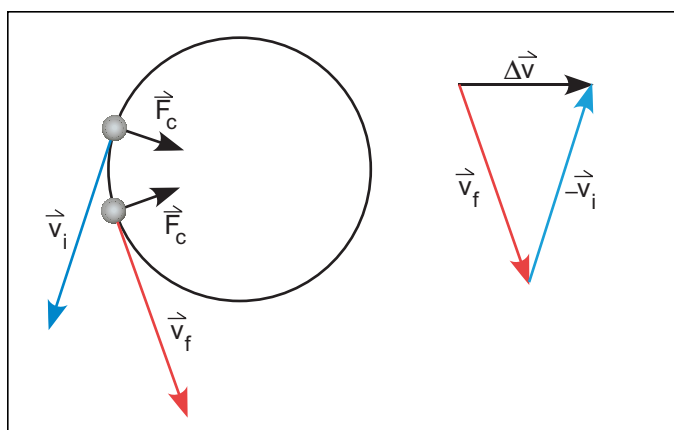

**SKILLS AND ATTITUDES OUTCOME**

**S4P-0-2a:** Select and use appropriate visual, numeric, graphical, and symbolic modes of representation to identify and represent relationships.

**GENERAL LEARNING OUTCOME CONNECTION**

*Students will...*

Demonstrate curiosity, skepticism, creativity, open-mindedness, accuracy, precision, honesty, and persistence, and appreciate their importance as scientific and technological habits of mind (GLO C5)

**SUGGESTIONS FOR INSTRUCTION**

**SUGGESTIONS FOR ASSESSMENT**

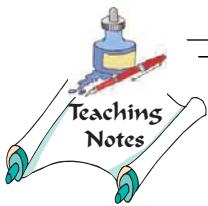



**GENERAL LEARNING OUTCOME CONNECTION**

*Students will...*

Evaluate, from a scientific perspective, information and ideas encountered during investigations and in daily life (GLO C8)

**SPECIFIC LEARNING OUTCOME**

**S4P-1-20: Discuss the centrifugal effects with respect to Newton's laws.**



---

**SUGGESTIONS FOR INSTRUCTION**

**Entry Level Knowledge**

Newton's laws are covered in Senior 2 Science and Senior 3 Physics.

**Notes to the Teacher**

If you are in the front seat of a car and the car suddenly turns in a circular path, counterclockwise, you will be "thrown" to the right-hand side of the car. You will feel as if there is a force moving you. Such a force, which appears to be directed away from the centre of the path, is often called a centrifugal "force." As the car moves in a circular path, inertia keeps your body going in a straight line. This path causes you to move to the right-hand side of the car, which is turning. The centrifugal "force" feels real, but it doesn't really exist. Consequently, most physicists prefer the term "centrifugal effect" rather than "centrifugal force."

Often, this outward force is attributed to circular motion. For example, everything on a rotating platform behaves as if there was a mysterious force pulling outwards. Tall objects tend to topple over and small ones try to slide away from the centre. Some people refer to this as centrifugal "force," but there really is no force at all. Centrifugal means "centre-fleeing" or "away from the centre." Centrifugal "force" can be explained by the absence of a force to keep the object moving in circular motion. If an object in uniform circular motion is suddenly released, the object will move off in a straight line at a constant speed according to Newton's Law of Inertia. Sometimes, it is useful to use a frame of reference that is rotating with the system. In such a system, the centrifugal "force" appears mathematically. But, when the same situation is examined from a stationary frame, such as the ground, it does not exist.



**SKILLS AND ATTITUDES OUTCOME**

**S4P-0-4e:** Demonstrate a continuing and more informed interest in science and science-related issues.

**GENERAL LEARNING OUTCOME CONNECTION**

*Students will...*

Understand how stability, motion, forces, and energy transfers and transformations play a role in a wide range of natural and constructed contexts (GLO D4)

**SUGGESTIONS FOR INSTRUCTION**

**SUGGESTIONS FOR ASSESSMENT**

**Classroom Activities**

Have students predict the path of an object moving in uniform circular motion when it is suddenly released. The object could be attached to the end of string or a marble rolling around the inside of a ice cream pail lid with one portion of the lid removed.

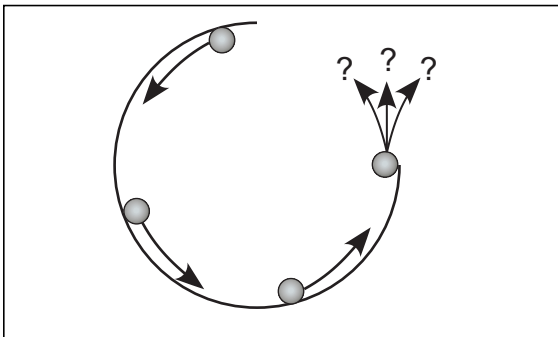

**Demonstration**

A centrifuge is a useful device for separating substances; for example, a cream separator on a farm or a blood centrifuge in the hospital. A simple centrifuge can be made with an old turntable, some cups, and some objects such as ping pong balls (see Appendix 1.9 for details).



**GENERAL LEARNING OUTCOME CONNECTION**

Students will...

Recognize that scientific knowledge is based on evidence, models, and explanations, and evolves as new evidence appears and new conceptualizations develop (GLO A2)

**SPECIFIC LEARNING OUTCOME**

**S4P-1-21: Draw free-body diagrams of an object moving in uniform circular motion.**

**SKILLS AND ATTITUDES OUTCOMES**

**S4P-0-2h: Analyze problems using vectors.**



Include: Adding and subtracting vectors in straight lines, at right angles, and at non-orthogonal angles

**SUGGESTIONS FOR INSTRUCTION**

**Entry Level Knowledge**

Free-body diagrams are covered in Senior 3 Physics.

**Notes to the Teacher**

Students can draw free-body diagrams to illustrate forces acting on a sphere or a coin moving in a uniform circular motion. In each case, they should indicate the force(s) responsible for the centripetal force. The relative length of the vectors corresponding to the forces should be drawn to scale.

Symbols:

$F_g$  — Weight

$F_T$  — Tension

$F_f$  — Friction

$F_N$  — Normal Force

$F_C$  — Centripetal Force

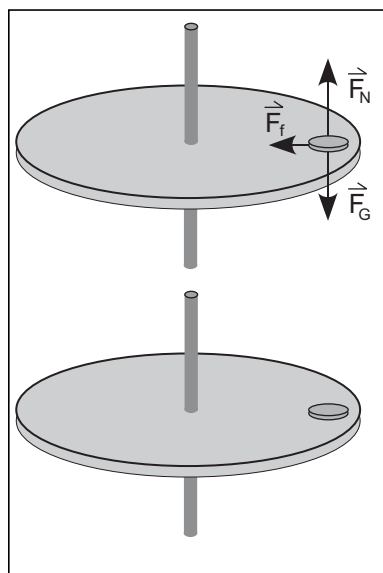

Rotating Coin

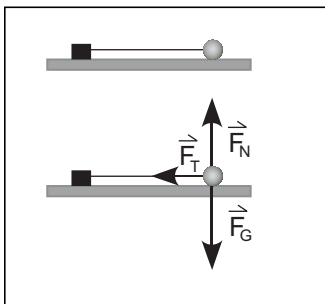

Rotating Sphere



**SKILLS AND ATTITUDES OUTCOMES**

**S4P-0-2i:** Select and integrate information obtained from a variety of sources.

Include: print, electronic, specialists, or other resource people

**S4P-0-4b:** Work co-operatively with a group to identify prior knowledge, initiate and exchange ideas, propose problems and their solution, and carry out investigations.

**GENERAL LEARNING OUTCOME CONNECTION**

*Students will...*

Demonstrate appropriate scientific inquiry skills when seeking answers to questions (GLO C2)

**SUGGESTIONS FOR INSTRUCTION**

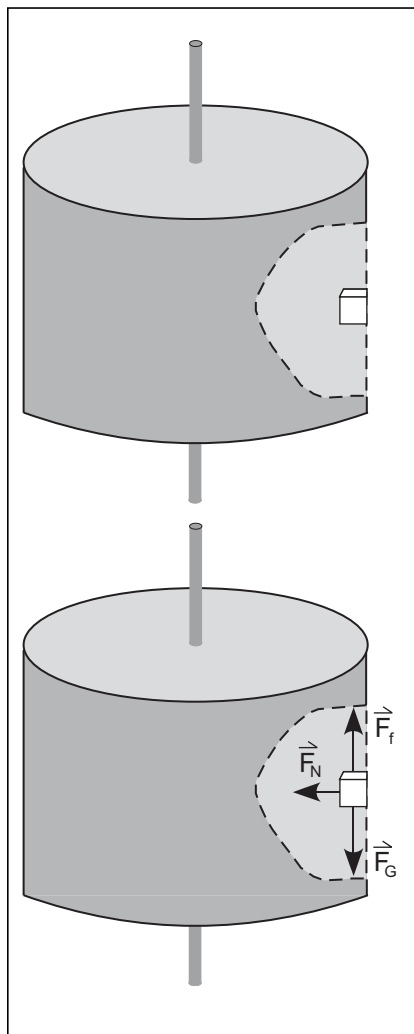

**Rotating Cylinder**

**SUGGESTIONS FOR ASSESSMENT**

**Visual Displays**

Students design and construct a model of an amusement park ride. The forces acting are described using a free-body diagram.

**SUGGESTED LEARNING RESOURCES**

Going in Circles, Activity 30, p 183, Lab Manual, *Conceptual Physics*, Pearson, 2002



**GENERAL LEARNING OUTCOME CONNECTION**

*Students will...*

Demonstrate appropriate problem-solving skills while seeking solutions to technological challenges (GLO C3)

**SPECIFIC LEARNING OUTCOME**

**S4P-1-22: Experiment to determine the mathematical relationship between period and frequency and one or more of the following: centripetal force, mass, and radius.**

**SKILLS AND ATTITUDES OUTCOMES**

**S4P-0-1e:** Differentiate between how scientific theories explain natural phenomena and how scientific laws identify regularities and patterns in nature.

**S4P-0-2a:** Select and use appropriate visual, numeric, graphical, and symbolic modes of representation to identify and represent relationships.



**SUGGESTIONS FOR INSTRUCTION**

**Entry Level Knowledge**

Students have used graphical analysis to investigate mostly linear relationships. In this case, graphical analysis is extended to the power and inverse relationships.

**Notes to the Teacher**

The common approach to investigating the relationships for circular motion is by swinging a rubber stopper as shown in the diagram. Several factors can be measured, including frequency, period, mass, radius, and force.

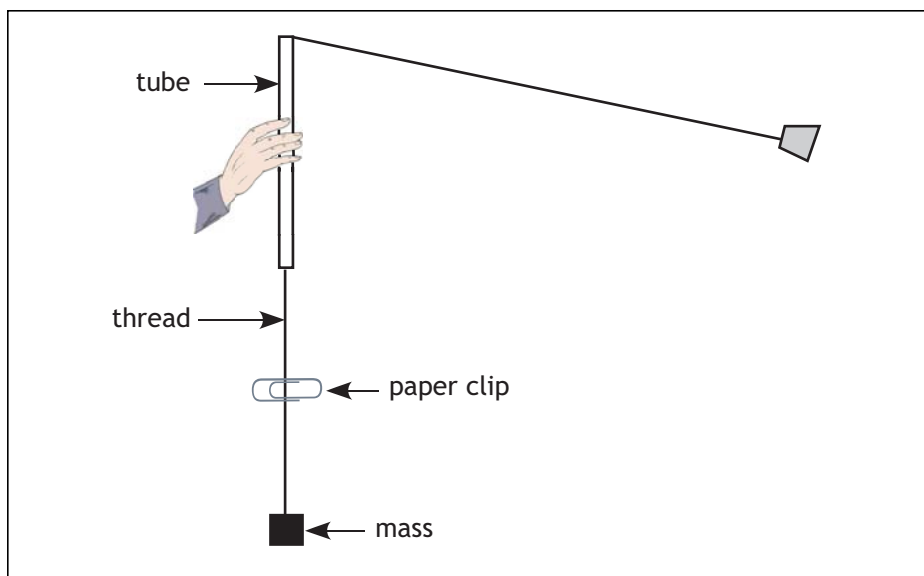

**SKILLS AND ATTITUDES OUTCOMES**

**S4P-0-2b:** Propose problems, state hypotheses, and plan, implement, adapt, or extend procedures to carry out an investigation where required.

**S4P-0-2c:** Formulate operational definitions of major variables or concepts.

**S4P-0-2d:** Estimate and measure accurately using SI units.

**S4P-0-2e:** Evaluate the relevance, reliability, and adequacy of data and data-collection methods.

Include: discrepancies in data and sources of error

**S4P-0-2f:** Record, organize, and display data using an appropriate format.

Include: labelled diagrams, tables, graphs

**S4P-0-2g:** Develop mathematical models involving linear, power, and/or inverse relationships among variables.

**GENERAL LEARNING OUTCOME CONNECTION**

*Students will...*

Work co-operatively and value the ideas and contributions of others while carrying out scientific and technological activities (GLO C7)

**SUGGESTIONS FOR INSTRUCTION**

**SUGGESTIONS FOR ASSESSMENT**

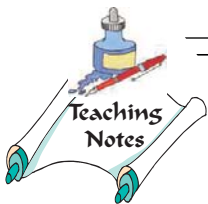

Empty box for suggestions for instruction.

**Laboratory Report**

Students collect, organize, and graphically illustrate data obtained and submit a lab report.

**SUGGESTED LEARNING RESOURCES**

Investigation 11-B: Verifying the Circular Motion Equation, *Physics 12*, McGraw-Hill Ryerson, 2003



**GENERAL LEARNING OUTCOME CONNECTION**

Students will...

Recognize that scientific knowledge is based on evidence, models, and explanations, and evolves as new evidence appears and new conceptualizations develop (GLO A2)

**SPECIFIC LEARNING OUTCOMES**



**S4P-1-23: Derive an equation for the constant speed and acceleration of an object moving in a circle**

$$\left( \vec{v} = \frac{2\pi r}{T}, a = \frac{v^2}{R} \right).$$

**S4P-1-24: Solve problems for an object moving with a constant speed in a circle using**

$$a = \frac{v^2}{R}, \vec{v} = \frac{2\pi r}{T}, \text{ and } \vec{F}_{\text{net}} = m\vec{a}.$$

**SUGGESTIONS FOR INSTRUCTION**

**Notes to the Teacher**

The equation for the constant speed of an object moving in a circle is derived from basic principles. We know that

$$v = \frac{\Delta d}{\Delta t}$$

and, for an object moving in a circle, that the path is the circumference of the circle. That is  $\Delta d = 2\pi R$ .

Therefore,  $\vec{v} = \frac{2\pi r}{T}$ .

There are several ways to derive  $a = \frac{v^2}{R}$ .

Remind students that vectors can be moved anywhere as long as the magnitude and direction do not change. Compare the triangles formed from

the position vectors  $(\Delta \vec{R} = \vec{R}_2 - \vec{R}_1)$

and the velocity vectors  $(\Delta \vec{v} = \vec{v}_2 - \vec{v}_1)$ .

Since these triangles are similar, the ratio of the corresponding sides are equal and,  $\frac{\Delta R}{R} = \frac{\Delta v}{v}$ ,

divide both sides by  $\Delta t$  to get  $\frac{\Delta R}{R\Delta t} = \frac{\Delta v}{v\Delta t}$ .

Since  $v = \frac{\Delta R}{\Delta t}$  and  $a = \frac{\Delta v}{\Delta t}$ , this reduces to  $\frac{v}{R} = \frac{a}{v}$

and finally  $a = \frac{v^2}{R}$ .

Notice this is a scalar equation; however, the direction of the acceleration will always be toward the centre of the circle.

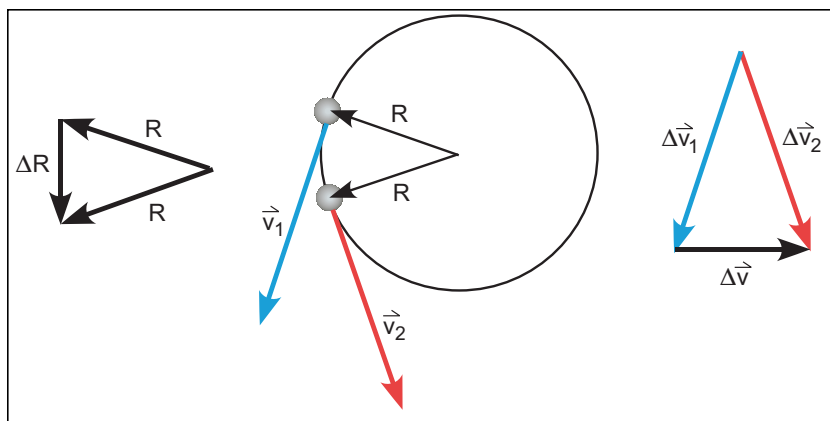

**SKILLS AND ATTITUDES OUTCOME**

**S4P-0-2g:** Develop mathematical models involving linear, power, and/or inverse relationships among variables.

**GENERAL LEARNING OUTCOME CONNECTION**

*Students will...*

Demonstrate appropriate scientific inquiry skills when seeking answers to questions (GLO C2)

Understand how stability, motion, forces, and energy transfers and transformations play a role in a wide range of natural and constructed contexts (GLO D4)

**SUGGESTIONS FOR INSTRUCTION**

**SUGGESTIONS FOR ASSESSMENT**

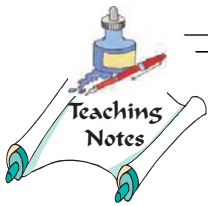

A large, empty rectangular box intended for writing suggestions for instruction.

Students write process notes to outline the steps of the derivations.

Given the diagram, students draw the similar triangles and state the ratio of the corresponding sides.





## NOTES



---

## **TOPIC 1.6: WORK AND ENERGY**

- S4P-1-25 Define work as the product of displacement and the component of force parallel to the displacement when the force is constant.
- S4P-1-26 Determine work from the area under the force-position graph for any force.  
Include: positive or negative force, uniformly changing force
- S4P-1-27 Describe work as a transfer of energy.  
Include: positive and negative work, kinetic work, conservation of energy
- S4P-1-28 Give examples of various forms of energy and describe qualitatively the means by which they can perform work.
- S4P-1-29 Derive the equation for kinetic energy using  $W = \vec{F} \cdot \Delta \vec{d} \cos \theta$  and kinematics equations.
- S4P-1-30 Derive the equation for gravitational potential energy near the surface of the Earth ( $E_p = mgh$ ).
- S4P-1-31 Experiment to determine Hooke's Law  $\left( \vec{F} = -k \vec{x} \right)$ .
- S4P-1-32 Derive an equation for the potential energy of a spring, using Hooke's Law and a force-displacement graph.
- S4P-1-33 Solve problems related to the conservation of energy.  
Include: gravitational and spring potential, and kinetic energy
-

**GENERAL LEARNING OUTCOME CONNECTION**

*Students will...*

Recognize that scientific knowledge is based on evidence, models, and explanations, and evolves as new evidence appears and new conceptualizations develop (GLO A2)

**SPECIFIC LEARNING OUTCOME**



**S4P-1-25: Define work as the product of displacement and the component of force parallel to the displacement when the force is constant.**

**SUGGESTIONS FOR INSTRUCTION**

**Entry Level Knowledge**

In Senior 3 Physics, students developed an understanding of net force and of concepts of force of friction, normal force, gravitational force, and applied forces.

**Notes to the Teacher**

Newton’s laws provide a useful means for analyzing motion in terms of force, mass, velocity, and acceleration. There are other ways to look at motion. In this topic, motion will be analyzed using the concepts of work and energy.

In physics, work is defined as a **force** acting upon an object, which results in a displacement of the object. Work is a familiar everyday concept. For example, it takes work to push a stalled car, lift a book above the table, or open a door. Force and displacement are the two essential elements of work. Mathematically, the work done on an object by a constant force (constant in both magnitude and direction) is defined as the product of the magnitude of the displacement times the component of the force in the direction of the displacement.

Work =  $F_{\text{net}} \Delta d \cos \theta$ , where  $F_{\text{net}}$  is the magnitude of the constant force,  $\Delta d$  is the magnitude of the displacement of the object, and  $\theta$  is the angle between the direction of the force and the displacement. Note that if the displacement is zero, the work is zero, even if a force is applied. The  $\theta$  factor is present because  $F_{\text{net}} \cos \theta$  is the component of the force in the direction of the displacement. If the angle between the force and the displacement is zero,  $\cos \theta = 1$ .

Work is a scalar quantity—therefore, it has only a magnitude. The SI unit of work is a Newton-meter called the Joule (J), in honour of James Prescott Joule (1818–1889). However, note that work can be positive or negative, depending on whether work is gained or lost by the system.

Illustrative examples are in Appendix 1.8: Force-Work Relationships.



**SKILLS AND ATTITUDES OUTCOME**

**S4P-0-2c:** Formulate operational definitions of major variables or concepts.

**GENERAL LEARNING OUTCOME CONNECTION**

*Students will...*

Recognize that characteristics of materials and systems can remain constant or change over time, and describe the conditions and processes involved (GLO E3)

**SUGGESTIONS FOR INSTRUCTION**

**SUGGESTIONS FOR ASSESSMENT**

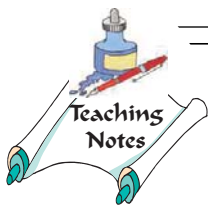

A large empty rectangular box for providing suggestions for instruction.

**Pencil-and-Paper Tasks**

Students solve various types of problems involving:

1. single force acting horizontally and at an angle;
2. multiple forces acting horizontally and at angles; or
3. using either/both methods.



**GENERAL LEARNING OUTCOME CONNECTION**

Students will...

Demonstrate appropriate scientific inquiry skills when seeking answers to questions (GLO C2)

**SPECIFIC LEARNING OUTCOME**

**S4P-1-26: Determine work from the area under the force-position graph for any force.**

Include: positive or negative force, uniformly changing force



**SUGGESTIONS FOR INSTRUCTION**

**Entry Level Knowledge**

Students should be able to calculate the areas of a rectangle, triangle, and trapezoid and be familiar with resolving units (i.e.,  $m/s \times s = m$ , displacement quantity unit).

**Notes to the Teacher**

If the force acting on an object is constant, the work done by that force can be calculated using the equation established in S4P-1-25. If the force varies in magnitude or direction, the work done must be determined by calculating the area under the curve of a force vs. displacement graph. Note, in general, work can always be calculated using the area method, but the product of force and displacement can only be used if the force is constant.

$$W_1 = \text{Area of a rectangle (L1)} \\ = F_1 d_1 \quad (+ \text{ value})$$

$$W_2 = \text{Area of a trapezoid } ((B + b)h/2) \\ = \frac{(F_1 + F_2)}{2} (d_2 - d_1) \quad (+ \text{ value})$$

$$W_3 = \text{Area of a triangle } (bh/2) \\ = \frac{F_3 (d_3 - d_2)}{2} \quad (\text{having—value})$$

$$W_t = W_1 + W_2 + W_3$$

Example:

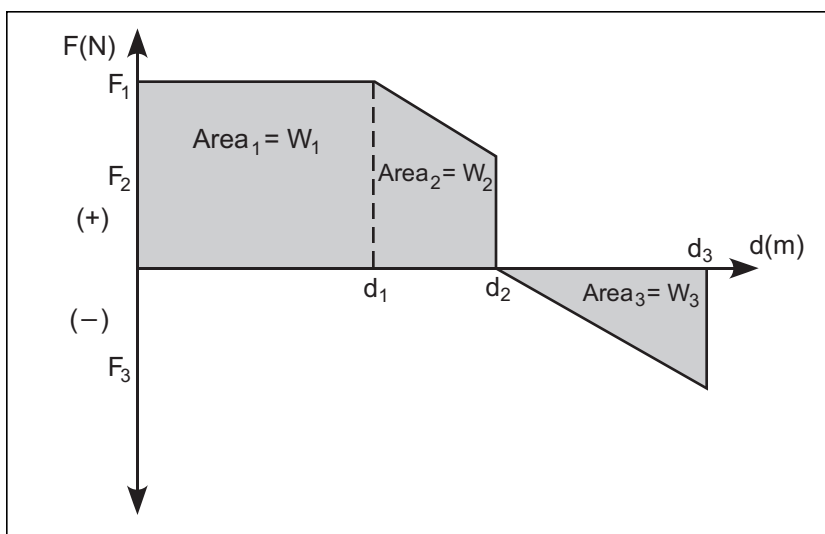

**SKILLS AND ATTITUDES OUTCOMES**

**S4P-0-2a:** Select and use appropriate visual, numeric, graphical, and symbolic modes of representation to identify and represent relationships.

**S3P-0-2d:** Estimate and measure accurately using SI units.

**GENERAL LEARNING OUTCOME CONNECTION**

*Students will...*

Understand how stability, motion, forces, and energy transfers and transformations play a role in a wide range of natural and constructed contexts (GLO D4)

**SUGGESTIONS FOR INSTRUCTION**

**SUGGESTIONS FOR ASSESSMENT**

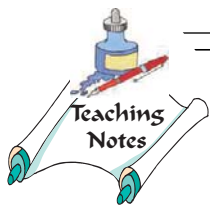

A large, empty rectangular box intended for handwritten notes or instructions.

**Pencil-and-Paper Tasks**

Students evaluate total work done given a graph with constant and uniformly changing forces, positive as well as negative.

**Collaborative Teamwork**

Students exchange stories that describe some form of motion and change in motion. Each group draws free-body diagrams and then qualitatively describes the work done throughout the motion.



**GENERAL LEARNING OUTCOME CONNECTION**

*Students will...*

Describe and appreciate how the natural and constructed worlds are made up of systems and how interactions take place within and among these systems (GLO E2)

**SPECIFIC LEARNING OUTCOMES**

**S4P-1-27: Describe work as a transfer of energy.**

Include: positive and negative work, kinetic energy, conservation of energy

**S4P-1-28: Give examples of various forms of energy and describe qualitatively the means by which they can perform work.**



**SUGGESTIONS FOR INSTRUCTION**

**Entry Level Knowledge**

Students should understand that the  $+/-$  sign assigned to work does not imply direction since work is a scalar quantity. Learning outcome S4P-1-1 explains that positive work results if work is gained, and negative work results if work is lost.

**Notes to the Teacher**

In all cases, an object must possess some form of energy to do work. Commonly, an agent doing the work (a student, a car, a batter, a motor) will have **chemical potential energy** stored in food or fuel, which is transformed into work. In the process of doing work, the objects doing the work exchange energy—one gains and one loses. A force doing positive work on an object will transfer its energy to the object and increase the energy of that object. A force doing negative work will decrease the energy of that object and will have energy transferred from the object to the agent exerting the force. Energy is conserved by simply being transferred from the agent to the object or vice versa, depending on the direction of the force relative to the displacement. We call energy that is possessed by an object, due to its motion or its stored energy of position, **mechanical energy**.

For example, when you lift an object, potential chemical energy in the glucose molecules in your muscles allow you to do work on the object. Initially, the work done by you is converted into gravitational potential energy as the object rises, as well as kinetic energy as the object is put in motion. In the end, the gain in energy equals the loss in potential chemical energy in your muscles. A curling rock once released has a certain speed and therefore kinetic energy, which will gradually be converted into thermal energy as friction acts in the opposite direction of the movement of the curling rock.

Different types of energy have one thing in common: they imply a system capable of doing work. Additionally, all types of energy may be subdivided into two different categories: potential energy ( $E_p$  or  $U$ ) or kinetic energy ( $E_k$ ).

**Potential energy** is energy stored in a system, which could be used to do work. For example, energy behind a dam has potential gravitational energy ( $E_g$  or  $U_g$ ), which can be used to do work to turn the turbines. A stretched spring or elastic or a compressed spring has potential elastic energy, which can be used to do work to propel an object. A gas has heat of vaporization, which can be released to do work when it condenses, as in a steam engine. A combustible such as propane or octane has potential chemical energy, which can be released to do work once it is burned in an engine.



**SKILLS AND ATTITUDES OUTCOMES**

**S4P-0-2a:** Select and use appropriate visual, numeric, graphical, and symbolic modes of representation to identify and represent relationships.

**S3P-0-4b:** Work co-operatively with a group to identify prior knowledge, initiate and exchange ideas, propose problems and their solution, and carry out investigations.

**GENERAL LEARNING OUTCOME CONNECTION**

*Students will...*

Recognize that energy, whether transmitted or transformed, is the driving force of both movement and change, and is inherent within materials and in the interactions among them (GLO E4)

**SUGGESTIONS FOR INSTRUCTION**

**Kinetic energy** is energy by virtue of being in motion. Kinetic energy can be used to do work when one thing interacts with something else. For example, at the macroscopic level (visible): a swinging bat has kinetic energy and does work hitting a ball transferring the kinetic energy to the ball. At the microscopic or invisible level: heat contained in matter is due to the sum of the kinetic energies of all the particles that compose that matter. In gaseous matter, the particles are continually in motion; even in a solid, particles have a vibrational motion. The greater the motion of these particles, the greater is the heat content of that matter. The electric current in a wire is simply the motion of electrons in that wire. The kinetic energy of the electrons is called electrical energy, which can be used to do work as in an electric motor. Electromagnetic radiation (radio waves, IR, visible light, UV, X-rays,  $\gamma$ -rays) are photons in motion at a speed of  $3.0 \times 10^8$  m/s in a vacuum.

**SUGGESTIONS FOR ASSESSMENT**

**Visual Display**

Students create posters to describe situations that depict the transfer of energy from one object to another.





**GENERAL LEARNING OUTCOME CONNECTION**

Students will...

Recognize that scientific knowledge is based on evidence, models, and explanations, and evolves as new evidence appears and new conceptualizations develop (GLO A2)

**SPECIFIC LEARNING OUTCOME**

**S4P-1-29: Derive the equation for kinetic energy using**

$$W = \vec{F} \cdot \Delta \vec{d} \cos \theta$$

**and kinematics equations.**

**S4P-1-30: Derive the equation for gravitational potential energy near the surface of the Earth ( $E_p = mgh$ ).**



**SUGGESTIONS FOR INSTRUCTION**

**Entry-Level Knowledge**

Kinematic equations in S4P-1-1 are used to derive the equation for kinetic energy.

**Notes to the Teacher**

In the section on momentum, a new variable was introduced from the product  $F\Delta t$ , which we called **impulse**. This variable is equivalent to the change in momentum,  $m\Delta v$ ; i.e.,  $F\Delta t = m\Delta v = m(v_f - v_i)$ . Since the mass travels  $\Delta d$  during the time  $t$ , not only is an impulse given to the mass, but work equivalent to  $F\Delta d$  is also done on the mass. We know from the previous section that this work becomes kinetic energy if the mass is subjected to a constant force on a horizontal surface with no friction present. As with momentum, we will derive an expression in terms of  $m$  and  $v$ , equivalent to the work done on the mass.

Since a constant force acting on a mass results in a uniformly accelerated motion, and we want to include  $\Delta d$  in our equation instead of  $\Delta t$ , let us begin our derivation with the following kinematic equation:

$$v_f^2 = v_i^2 + 2a\Delta d$$

or  $v_f^2 - v_i^2 = 2a\Delta d$

or  $a\Delta d = \frac{v_f^2}{2} - \frac{v_i^2}{2}$  (1)

Multiply both sides of the equation (1) by  $m$ ,

$$ma\Delta d = \frac{mv_f^2}{2} - \frac{mv_i^2}{2} \quad (2)$$

Since  $F = ma$ , rewrite (2) as

$$F\Delta d = \frac{mv_f^2}{2} - \frac{mv_i^2}{2} \quad (3)$$

where  $F\Delta d$  represents the work ( $W$ ) done on mass, and  $m$  and  $1/2 mv^2$  corresponds to kinetic energy ( $E_k$ ).

Equation (3) can therefore be rewritten as

$$W = E_{kf} - E_{ki} = \Delta E_k$$

For an object of mass,  $m$ , being pulled a distance,  $\Delta d$ , by a force,  $F$ , on a horizontal surface where no friction is present, the work done on the object is equivalent to a change in its kinetic energy due to a change in its speed from  $v_i$  to  $v_f$ .

In terms of units:

$$W = N \cdot m = J$$

$$E_k = kg \cdot \left(\frac{m}{s}\right)^2 = kg \cdot \frac{m^2}{s^2} = \frac{kg \cdot m}{s^2} \cdot m = N \cdot m = J$$



**SKILLS AND ATTITUDES OUTCOME**

**S4P-0-2g:** Develop mathematical models involving linear, power, and/or inverse relationships among variables.

**GENERAL LEARNING OUTCOME CONNECTION**

*Students will...*

Understand the composition of the universe, the interactions within it, and the impacts of humankind's continued attempts to understand and explore it (GLO D6)

**SUGGESTIONS FOR INSTRUCTION**

Kinetic energy was at the centre of a debate that took place at the beginning of the 18th century. Descartes insisted that momentum was the most important quantity in dynamics, while Leibniz believed that the important quantity was kinetic energy. The question was, what is more important: the time a force acts or the distance through which a force acts?

Near the surface of the Earth, the gravitational force can be considered to be constant. Therefore, the amount of work done to lift an object of mass,  $m$ , a height,  $h$ , is  $W = F\Delta d = Fh$  where  $F$  is the average force to lift the object; i.e., its weight,  $F_g$ . That work becomes gravitational potential energy ( $E_g$  or  $U_g$ ).

Therefore,  $E_g = F_g h$

$$E_g = mgh, \text{ where } g = 9.81 \text{ N/kg.}$$

$E_g$  represents the potential gravitational energy of mass,  $m$ , from a height,  $h$ .

In terms of units,

$$E_g = kg \cdot \frac{m}{s^2} \cdot m = \frac{kg \cdot m}{s^2} \cdot m = N \cdot m = J$$

**SUGGESTIONS FOR ASSESSMENT**

Students use process notes to outline the steps for the derivation of the energy equations.

Students compare/contrast work-energy to impulse momentum.

Students make simple calculations for the energy of various objects in motion or at rest above the surface of the Earth.



**GENERAL LEARNING OUTCOME CONNECTION**

*Students will...*

Demonstrate appropriate scientific inquiry skills when seeking answers to questions (GLO C2)

**SPECIFIC LEARNING OUTCOME**

**S4P-1-31: Experiment to determine Hooke's law**

$$\left( \vec{F} = -k \vec{x} \right).$$

**SKILLS AND ATTITUDES OUTCOMES**

**S4P-0-1e:** Differentiate between how scientific theories explain natural phenomena and how scientific laws identify regularities and patterns in nature. 

**S4P-0-2a:** Select and use appropriate visual, numeric, graphical, and symbolic modes of representation to identify and represent relationships.

**SUGGESTIONS FOR INSTRUCTION**

**Notes to the Teacher**

Hooke's experiment is very common and very simple to perform. Suspend a spring from a fixed support. Add mass to the spring in equal increments (to increase the force). Record the stretch of the spring and graph force versus stretch ( $x$ ). The slope of the line is the " $k$ " spring constant. The spring constant is large when you are using very stiff springs (like springs in a car) and small for springs that stretch very easily.

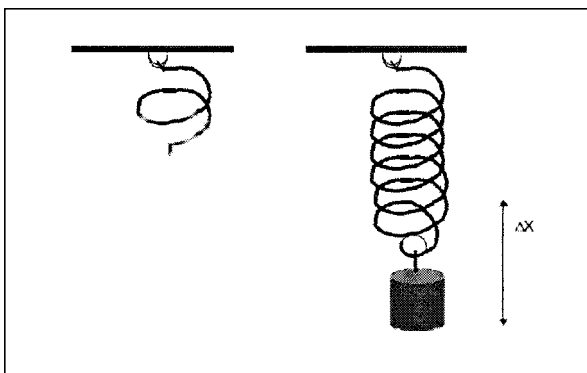

**SKILLS AND ATTITUDES OUTCOMES**

**S4P-0-2b:** Propose problems, state hypotheses, and plan, implement, adapt, or extend procedures to carry out an investigation where required.

**S4P-0-2c:** Formulate operational definitions of major variables or concepts.

**S4P-0-2d:** Estimate and measure accurately using SI units.

**S4P-0-2e:** Evaluate the relevance, reliability, and adequacy of data and data-collection methods.

Include: discrepancies in data and sources of error

**S4P-0-2f:** Record, organize, and display data using an appropriate format.

Include: labelled diagrams, tables, graphs

**S4P-0-2g:** Develop mathematical models involving linear, power, and/or inverse relationships among variables.

**GENERAL LEARNING OUTCOME CONNECTION**

*Students will...*

Demonstrate curiosity, skepticism, creativity, open-mindedness, accuracy, precision, honesty, and persistence, and appreciate their importance as scientific and technological habits of mind (GLO C5)

**SUGGESTIONS FOR INSTRUCTION**

**SUGGESTIONS FOR ASSESSMENT**

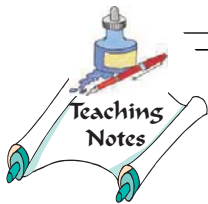

Empty box for suggestions for instruction.

Students collect and analyze data, and submit a lab report.

**SUGGESTED LEARNING RESOURCES**

Lab 5.3: Hooke’s Law, p. 192, *Physics: Concepts and Connections*, Irwin Publishing Ltd., 2003



**GENERAL LEARNING OUTCOME CONNECTION**

*Students will...*

Demonstrate appropriate critical thinking and decision-making skills when choosing a course of action based on scientific and technological information (GLO C4)

**SPECIFIC LEARNING OUTCOME**

**S4P-1-32: Derive an equation for the potential energy of a spring, using Hooke's Law and a force-displacement graph.**



**SUGGESTIONS FOR INSTRUCTION**

**Notes to the Teacher**

If you apply a force to a spring to stretch it, then you must be doing work since you are applying the force over a displacement. Since work is the transfer of energy, we say that energy is transferred into the spring. The work becomes stored potential energy in the spring. A spring can be stretched or compressed.

A linear restoring force stretches a spring in direct proportion to the amount of stretch. That is, the force vs. stretch graph forms a straight line that passes through the origin. The work is the area between the line and the axis.

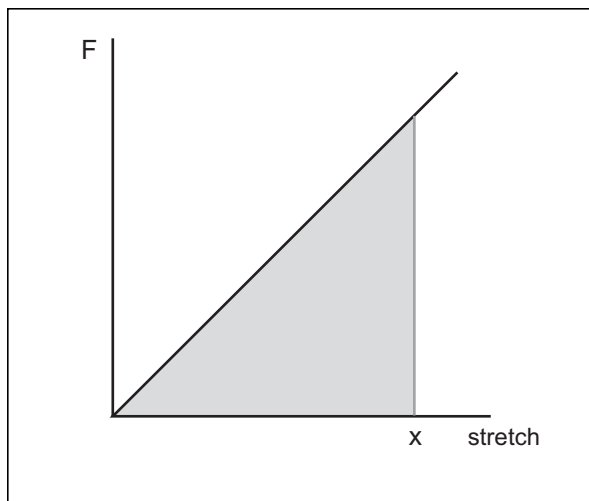

$$\text{Work} = \text{area of triangle} \left( \frac{1}{2}bh \right)$$

$$= \frac{1}{2}Fx$$

Since  $F = kx$

$$\text{Work} = \frac{1}{2}kx^2$$

$$\text{Spring Potential } (E_s \text{ or } U_s) = \frac{1}{2}kx^2$$



**SKILLS AND ATTITUDES OUTCOME**

**S4P-0-2g:** Develop mathematical models involving linear, power, and/or inverse relationships among variables.

**GENERAL LEARNING OUTCOME CONNECTION**

*Students will...*

Evaluate, from a scientific perspective, information and ideas encountered during investigations and in daily life (GLO C8)

**SUGGESTIONS FOR INSTRUCTION**

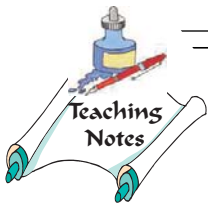

**SUGGESTIONS FOR ASSESSMENT**

Students use process notes to outline the steps for the derivation of spring potential energy.

Students compare/contrast spring and gravitational potential energy.

Students make simple calculations for the energy of various objects in motion, at rest above the surface of the Earth, or in terms of the stretch or compression of a spring.



**GENERAL LEARNING OUTCOME CONNECTION**

*Students will...*

Demonstrate appropriate scientific inquiry skills when seeking answers to questions (GLO C2)

**SPECIFIC LEARNING OUTCOME**

**S4P-1-33: Solve problems related to the conservation of energy.**

Include: gravitational and spring potential, and kinetic energy



**SUGGESTIONS FOR INSTRUCTION**

**Notes to the Teacher**

Various combinations of gravitational, kinetic, and spring potential can be found in a problem. Roller-coaster problems can illustrate changes in energy. “Pinball” types of problems can also combine all three forms of energy. For example, find the speed of the ball at point B and the compression of the spring at point C. At point A the energy is gravitational potential and kinetic, at point B the energy is all kinetic, and at point C, for maximum compression of the spring, the energy is gravitational and spring potential.

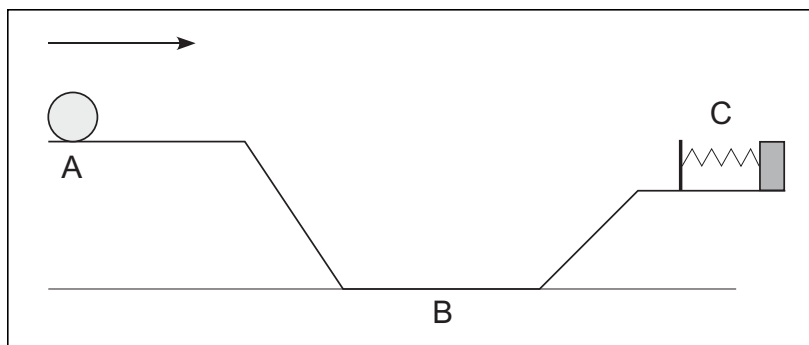

**SKILLS AND ATTITUDES OUTCOME**

**S4P-0-2g:** Develop mathematical models involving linear, power, and/or inverse relationships among variables.

**GENERAL LEARNING OUTCOME CONNECTION**

*Students will...*

Demonstrate appropriate scientific inquiry skills when seeking answers to questions (GLO C2)

**SUGGESTIONS FOR INSTRUCTION**

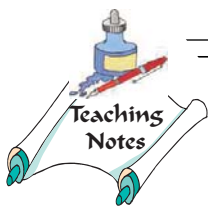

A large, empty rectangular box intended for instructional suggestions.

**SUGGESTIONS FOR ASSESSMENT**

**Pencil-and-Paper Tasks**

Students solve problems with various combinations of gravitational, spring, and kinetic energies.

**Collaborative Teamwork**

Students design a roller-coaster and calculate the energy and speed of the coaster at different points. They can also investigate the loop de loop.

Students exchange “pinball” problems. Each group provides the appropriate information and calculates the energy at various points.





NOTES



---

## ***TOPIC 2: FIELDS***

2.1: Exploration of Space

2.2: Low Earth Orbit

2.3: Electric and Magnetic Fields

---

---

## **TOPIC 2.1: EXPLORATION OF SPACE**

S4P-2-1 Identify and analyze issues pertaining to space exploration.

*Examples: scale of the universe, technological advancement, promotion of global co-operation, social and economic benefits, allocation of resources shifted away from other pursuits, possibility of disaster*

S4P-2-2 Describe planetary motion using Kepler's three laws.

*Examples: relate Kepler's Third Law to objects other than planets, such as comets, satellites, and spacecraft*

S4P-2-3 Outline Newton's Law of Universal Gravitation and solve problems using

$$F_g = \frac{Gm_1m_2}{r^2}.$$

S4P-2-4 State the gravitational potential energy as the area under the force-separation curve and solve problems using  $E_g = \frac{-Gm_1m_2}{r}$

S4P-2-5 Solve problems for the escape velocity of a spacecraft.

Include: Law of Conservation of Energy, binding energy

---

**GENERAL LEARNING OUTCOMES CONNECTION**

*Students will...*

Distinguish critically between science and technology in terms of their respective contexts, goals, methods, products, and values (GLO A3)

Describe scientific and technological developments, past and present, and appreciate their impact on individuals, societies, and the environment, both locally and globally (GLO B1)

**SPECIFIC LEARNING OUTCOME**



**S4P-2-1: Identify and analyze issues pertaining to space exploration.**

*Examples: scale of the universe, technological advancement, promotion of global co-operation, social and economic benefits, allocation of resources shifted away from other pursuits, possibility of disaster*

**SUGGESTIONS FOR INSTRUCTION**

**Entry Level Knowledge**

Research has indicated that students want to address contemporary topics in physics that they read about in the news and see on television. They have tremendous interest in expeditions such as Mars explorations, cosmology, and the new observations of the Hubble telescope.

It is highly recommended that teachers use a space exploration context to approach the topics of universal gravitation and Kepler’s laws. An excellent way to begin is with a student-initiated project that connects to learning outcome S4P-2-1. Projects could address different topics and take on many different forms. The historical analysis of technology, such as the development of the telescope from Galileo to Hubble, helps address the Nature of Science skills outcomes. Other students might focus on STSE issues. Students could also use a variety of presentation modes including web pages, a Web Quest, bulletin boards, photo album, video, PowerPoint, or alternative media. Refer to the appendix for Internet resources associated with specific issues.

**Notes to the Teacher**

The scale of the universe serves as an excellent introduction to the exploration of space. Students should be confronted with the macro scale and the micro scale. The Powers of Ten applet found on many websites can be used to introduce the scale. Encourage the construction of scale models.

**Demonstration**

Microsoft’s *Streets and Trips* software has a facility to mark locations along a given radius. Using the scale factors given in the table, students mark different locations relative to their home or school for the planets in the solar system.

Planet	Distance to Sun (million km)	Scale Factor
Mercury	58	0.39
Venus	108	0.72
Earth	150	1.00
Mars	228	1.52
Jupiter	778	5.19
Saturn	1,427	9.51
Uranus	2,871	19.1
Neptune	4,497	30.0
Pluto	5,913	39.4



**SKILLS AND ATTITUDES OUTCOMES**

- S4P-0-1c:** Relate the historical development of scientific ideas and technology to the form and function of scientific knowledge today.
- S4P-0-1d:** Describe how scientific knowledge changes as new evidence emerges and/or new ideas and interpretations are advanced.

- S4P-0-3a:** Analyze, from a variety of perspectives, the risks and benefits to society and the environment when applying scientific knowledge or introducing technology.
- S4P-0-3b:** Describe examples of how technology has evolved in response to scientific advances, and how scientific knowledge has evolved as the result of new innovations in technology.

**GENERAL LEARNING OUTCOME CONNECTION**

*Students will...*  
 Identify and appreciate contributions made by women and men from many societies and cultural backgrounds toward increasing our understanding of the world and in bringing about technological innovations (GLO A4)

**SUGGESTIONS FOR INSTRUCTION**

**SUGGESTIONS FOR ASSESSMENT**

**SKILLS AND ATTITUDES OUTCOMES (CONT'D)**

- S4P-0-3c:** Identify social issues related to science and technology, taking into account human and environmental needs and ethical considerations.
- S4P-0-3d:** Use the decision-making process to address an STSE issue.
- S4P-0-4c:** Demonstrate confidence in their ability to carry out investigations in science and to address STSE issues.
- S4P-0-4d:** Develop a sense of personal and shared responsibility for the impact of humans on the environment, and demonstrate concern for social and environmental consequences of proposed actions.
- S4P-0-4e:** Demonstrate a continuing and more informed interest in science and science-related issues.

Students conduct a “Space Day” Gallery Walk of student projects.

**SUGGESTED LEARNING RESOURCES**

<<http://education1.nasa.gov/home>> is an excellent resource with up-to-date information on the latest NASA projects.



**GENERAL LEARNING OUTCOME CONNECTION**

*Students will...*

Identify and appreciate contributions made by women and men from many societies and cultural backgrounds toward increasing our understanding of the world and in bringing about technological innovations (GLO A4)

**SPECIFIC LEARNING OUTCOME**



**S4P-2-2: Describe planetary motion using Kepler's three laws.**

*Examples: relate Kepler's Third Law to objects other than planets, such as comets, satellites, and spacecraft*

**SUGGESTIONS FOR INSTRUCTION**

**Notes to the Teacher**

Tycho Brahe provided a wide array of quantitative scientific observations but it was Johannes Kepler (1571–1630), who went to Prague to become Brahe's assistant, who was able to develop those observations in a theoretical framework. In the 16th century, most people believed in a geocentric model of the solar system, following the ancient ideas of astronomer Ptolemy. In 1543, Nicolaus Copernicus proposed an idea that the planets and Earth orbited around the Sun. However, Copernicus's new theory was no better at predicting the positions of the planets in the sky than Ptolemy's Earth-centred theory. More than 50 years later, Johannes Kepler set out to refine the Copernican system as he studied Tycho Brahe's observations of Mars. Kepler used Brahe's observations to guide the development of his laws of planetary motion, rather than fit the data to a predetermined view.

In 1609, Kepler published his first and second laws of planetary motion, the Law of Ellipses and the Equal-Areas Law. Ten years later he published a third law, the Harmonic Law. Kepler's three laws of planetary motion are:

- **First Law:** Each planet moves around the Sun in an orbit that is an ellipse, with the Sun at one focus of the ellipse.

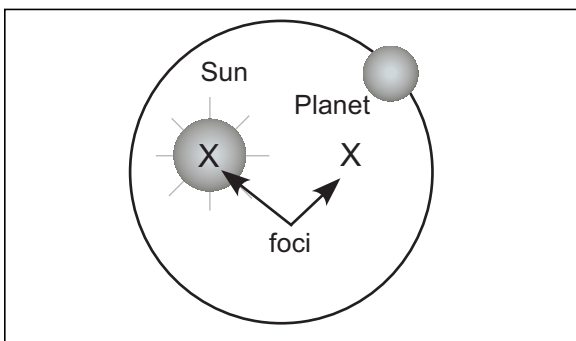

**Note:** The diagram is an exaggeration of the orbit. In reality, the foci are very close together, such that the orbit is very nearly circular.



**SKILLS AND ATTITUDES OUTCOMES**

**S4P-0-1d:** Describe how scientific knowledge changes as new evidence emerges and/or new ideas and interpretations are advanced.

**S4P-0-1e:** Differentiate between how scientific theories explain natural phenomena and how scientific laws identify regularities and patterns in nature.

**GENERAL LEARNING OUTCOME CONNECTION**

*Students will...*

Describe scientific and technological developments, past and present, and appreciate their impact on individuals, societies, and the environment, both locally and globally (GLO B1)

**SUGGESTIONS FOR INSTRUCTION**

**SUGGESTIONS FOR ASSESSMENT**

- **Second Law:** The straight line joining a planet and the Sun sweeps out equal areas in space in equal intervals of time. (Each planet moves most rapidly when closest to the Sun and least rapidly when farthest from the Sun.)

To demonstrate that the shaded areas are equal, draw the ellipse on a piece of paper (see instructions below) and cut out the pie-shaped wedges. Weigh the two pieces of paper on a scale (since the thickness of the paper is the same for each piece, the weight is proportional to the area).

**Observation**

Observe students and ask questions as they draw their ellipses.

**Pencil-and-Paper Tasks**

Students solve problems to calculate either radius of orbit or period, using Kepler’s constant.

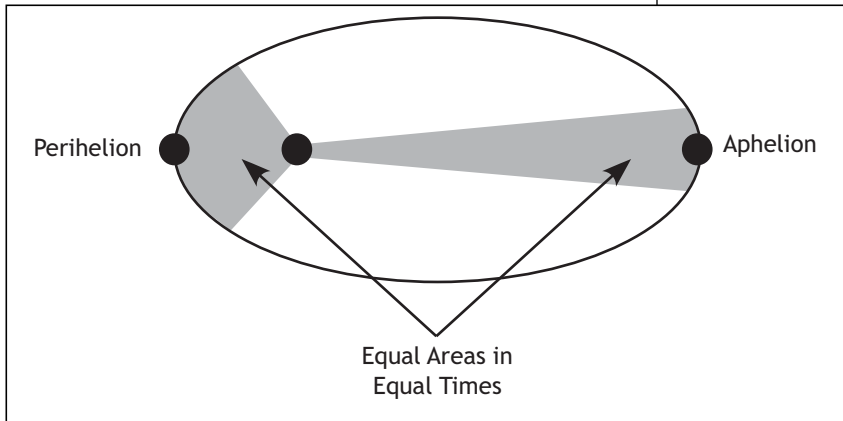

**GENERAL LEARNING OUTCOME CONNECTION**

Students will...

Identify and appreciate contributions made by women and men from many societies and cultural backgrounds toward increasing our understanding of the world and in bringing about technological innovations (GLO A4)

**SPECIFIC LEARNING OUTCOME**

**S4P-2-2: Describe planetary motion using Kepler’s three laws.**

Examples: relate Kepler’s Third Law to objects other than planets, such as comets, satellites, and spacecraft



**SUGGESTIONS FOR INSTRUCTION**

- **Third Law:** The squares of the orbital periods of the planets around the Sun are proportional to the cubes of the orbital semi-major axes.

If you know the time of a planet’s orbit around the Sun, you can calculate its average distance from the Sun (or vice-versa). The ratio of the cube of the radius of orbit to the square of the time is a constant, and Kepler’s Third Law can be stated as:

$$K_s = \frac{R^3}{T^2}$$

Students can use astronomical data from known tables to calculate and compare K for different planets.

**Prior Knowledge Activity**

Students create a KWL chart (SYSTH). Sample questions might include:

**Know**

- What is an orbit ?
- What are some things that orbit?
- What is the shape of an orbit?
- Do all orbits have the same shape?
- Are orbits natural or human-made?

**Want to Know**

- What do we want to learn about planetary orbits?
- Why don’t planets travel in straight lines?
- What’s in the middle of the orbit?

**Ellipse Activity**

Procedure

1. In a smooth, open area, mark two foci some distance apart. Place a stake in the ground at each focus, labelling one focus as the Sun.
2. Tie the ends of the rope together and loop the rope around the stakes at the foci.

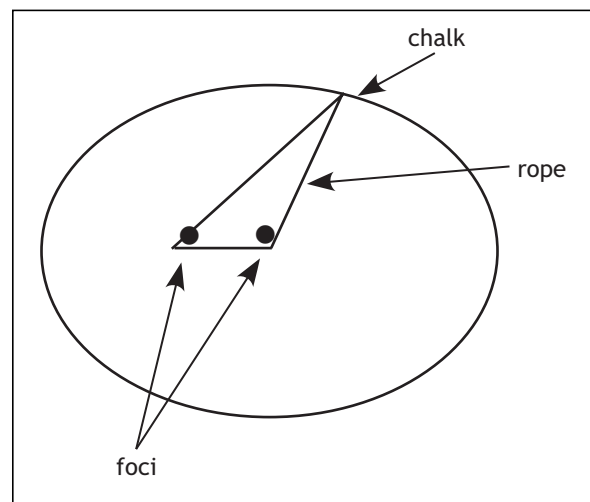



**SKILLS AND ATTITUDES OUTCOMES**

**S4P-0-1d:** Describe how scientific knowledge changes as new evidence emerges and/or new ideas and interpretations are advanced.

**S4P-0-1e:** Differentiate between how scientific theories explain natural phenomena and how scientific laws identify regularities and patterns in nature.

**GENERAL LEARNING OUTCOME CONNECTION**

*Students will...*

Describe scientific and technological developments, past and present, and appreciate their impact on individuals, societies, and the environment, both locally and globally (GLO B1)

**SUGGESTIONS FOR INSTRUCTION**

**SUGGESTIONS FOR ASSESSMENT**

3. Pull the rope tight, as shown, and, using the chalk, draw the ellipse as shown. Notice that for every point on the ellipse, the distance to one focus plus the distance to the other focus is always the same. Have students record the measurements to see the pattern for themselves.
4. Direct students to move around the path, slowing down as they get farther from the “Sun” and speeding up as they get closer.

The above exercise can also be done at a desk using paper and pencils, and pins.

**SUGGESTED LEARNING RESOURCES**

Reference: p. 279, *Nelson Physics 12*, Thomson Nelson, 2003

Activity: Drawing and comparing ellipses, p. 273, computerized simulation of Kepler’s Second Law, *Nelson Physics 12*, Thomson Nelson, 2003

Michael J. Ruiz, “Kepler’s Third Law without a Calculator,” *The Physics Teacher* 42 (December 2004): 530–538.

In this article, Ruiz presents an interesting and accessible procedure (based on the popular “Fermi Questions” approach) whereby students can use “mental mathematics” techniques (for instance, use of squares, cubes, cube roots of common values) to determine values for “R” (semi-major axis) and “T” (period) for planetary bodies, comets such as Halley, and spacecraft travel and its relation to least-energy orbits (also known as Hohmann transfer orbits (see learning outcome S4P-2-7). Designed for an astronomy course for college-level non-majors, the technique could be particularly useful in building student confidence in working with a numerical mode of representation. Kepler’s Third Law is simply stated in the form:

$$R \times R \times R = T \times T$$



**GENERAL LEARNING OUTCOME CONNECTION**

Students will...

Describe scientific and technological developments, past and present, and appreciate their impact on individuals, societies, and the environment, both locally and globally (GLO B1)

**SPECIFIC LEARNING OUTCOME**

**S4P-2-3: Outline Newton’s Law of Universal Gravitation and solve problems using**

$$F_g = \frac{Gm_1m_2}{r^2}$$



**SUGGESTIONS FOR INSTRUCTION**

**Entry Level Knowledge**

Students have studied gravity near the surface of the Earth in Senior 3 Physics.

**Notes to the Teacher**

One of Isaac Newton’s greatest ideas follows from the legend of the apple falling on his head. Newton surmised that if the force of gravity reaches to the top of the highest tree, might it not reach even further? Could the force of gravity extend all the way to the Moon? Then, the orbit of the Moon about Earth could be a consequence of the gravitational force and, further, could the force of gravity extend indefinitely? Newton concluded that any two objects in the universe exert a gravitational attraction on each other that is proportional to the product of their masses, and inversely proportional to the square of their separation.

$$F \propto \frac{m_1m_2}{R^2}$$

Introducing a constant of proportionality ( $G$ ), the law becomes:

$$F = G \frac{m_1m_2}{R^2}$$

A gravitational field exists in the space surrounding an object and a force is exerted on any mass in the field. The law holds for any two masses and the constant  $G$  is universal.

The value of  $G$  is found experimentally and was first measured by Henry Cavendish using a torsion balance. Cavendish attached two spheres to the ends of a rod suspended by a wire. The force of gravity exerted by two other, nearby, heavy objects caused the rod to twist. The angle of the torsion was proportional to the force of gravity exerted by the masses.

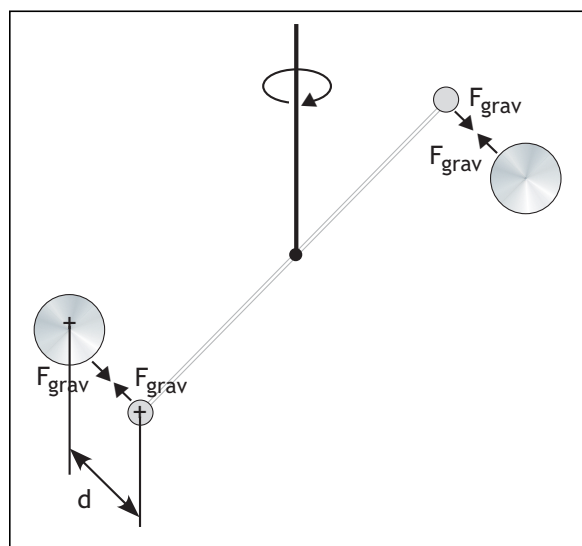

Cavendish’s Torsion Balance



**SKILLS AND ATTITUDES OUTCOME**

**S4P-0-1a:** Explain the roles of theory, evidence, and models in the development of scientific knowledge.

**GENERAL LEARNING OUTCOME CONNECTION**

*Students will...*

Understand the composition of the universe, the interactions within it, and the impacts of humankind's continued attempts to understand and explore it (GLO D6)

**SUGGESTIONS FOR INSTRUCTION**

In this way, Cavendish was able to determine the gravitational force of attraction between the masses, and the value of  $G$  could also be determined. The currently accepted value of  $G$  is  $6.67259 \times 10^{-11} \text{ N m}^2/\text{kg}^2$ . The value of  $G$  is very small, indicating that the force of gravity is only appreciable for objects with large masses. Although any two masses (including students) will exert gravitational forces upon each other, these forces are too small to be noticeable. However, in the case of planets, the gravitational force becomes much larger and noticeable.

**Student Activity**

Students calculate the weight (force of gravity) on an object near the surface and, using compare and contrast frames (SYSTH), compare to the force of gravity as calculated by Newton's Law of Universal Gravitation.

**SUGGESTIONS FOR ASSESSMENT****Pencil-and-Paper Tasks**

Students solve problems using Newton's Law of Universal Gravitation.

**SUGGESTED LEARNING RESOURCES**

Problems: pp. 276–277, *Nelson Physics 12*, Thomson Nelson, 2003

Reference: pp. 275–277, *Nelson Physics 12*, Thomson Nelson, 2003

Reference: pp. 182–184, *Conceptual Physics*, Pearson, 2002

Problem Sets: p. 275, *Nelson Physics 12*, Thomson Nelson, 2003



**GENERAL LEARNING OUTCOME CONNECTION**

Students will...

Demonstrate appropriate problem-solving skills while seeking solutions to technological challenges (GLO C3)

**SPECIFIC LEARNING OUTCOME**

**S4P-2-4: State the gravitational potential energy as the area under the force-separation curve and solve problems using**

$$E_g = \frac{-Gm_1m_2}{r}$$



**SUGGESTIONS FOR INSTRUCTION**

**Entry Level Knowledge**

Work and gravitational potential energy near the surface of Earth are introduced in Topic 1. The concepts are now extended to the general case.

**Notes to the Teacher**

Near the surface of Earth, work done lifting an object above the surface of Earth is stored as potential energy. Similarly, we must do work separating all masses. In the general case, the gravitational force is not constant, so work can only be calculated as the area under the force-separation curve. Calculus is required to find this area. At this time, most students are unprepared for integral calculations and the formula must be given. However, the idea of the area under a force-separation graph is covered in Topic 1 and can be extended to the limiting case in this example.

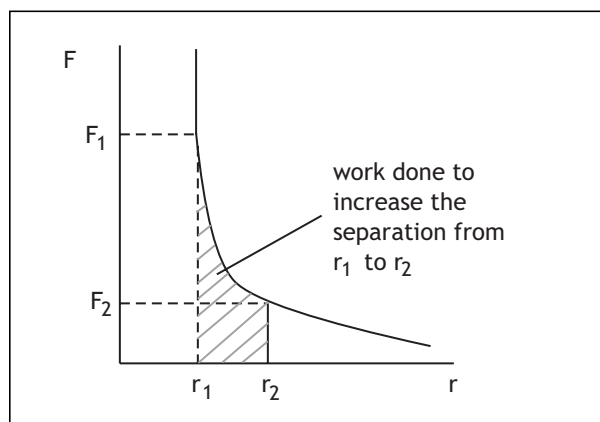

In the force-separation graph, the area under the curve for the interval  $r_1$  to  $r_2$  is equal to the work done in increasing the separation of the two masses.

To increase the separation of the two masses from  $r_1$  to  $r_2$  requires work to be done to overcome the force of attraction. As a result of this work being done, the gravitational potential energy of the system increases. At maximum separation (infinity), the gravitational potential energy is zero. Since energy was added to the system to “raise” it to zero, the initial energy is stated as a negative. The work done to change the separation from  $r_1$  to  $r_2$  equals the change in gravitational potential energy from  $r_1$  to  $r_2$ .

Students are often confused by the fact that the initial potential energy is negative. The negative sign indicates an attractive force and requires that energy be added to move towards a potential of zero. As the separation ( $r$ ) approaches infinity, the potential energy must approach zero. Physicists often refer to these types of energy problems as “potential wells.” An object at the bottom of a well requires energy to get it out of the well. If the top of the well is assigned a value of zero potential, then the bottom of the well must be negative potential. It is important to remember that the negative provides us with information about the situation.



**SKILLS AND ATTITUDES OUTCOME**

**S4P-0-2g:** Develop mathematical models involving linear, power, and/or inverse relationships among variables.

**GENERAL LEARNING OUTCOME CONNECTION**

*Students will...*

Demonstrate appropriate problem-solving skills while seeking solutions to technological challenges (GLO C3)

**SUGGESTIONS FOR INSTRUCTION**

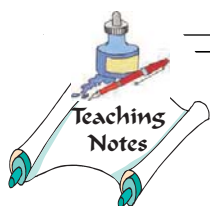

**SUGGESTIONS FOR ASSESSMENT**

**Pencil-and-Paper Tasks**

Students solve simple problems using gravitational potential energy.

**SUGGESTED LEARNING RESOURCES**

Problems: pp. 276–277, *Nelson Physics 12*, Thomson Nelson, 2003

Reference: pp. 275–277, *Nelson Physics 12*, Thomson Nelson, 2003

Reference: pp. 182–184, *Conceptual Physics*, Pearson, 2002

Problems: p. 275, *Nelson Physics 12*, Thomson Nelson, 2003

Problems: p. 286, *Nelson Physics 12*, Thomson Nelson, 2003

Reference: pp. 285–288, *Nelson Physics 12*, Thomson Nelson, 2003



**GENERAL LEARNING OUTCOME CONNECTION**

Students will...

Recognize that scientific and technological endeavours have been and continue to be influenced by human needs and the societal context of the time (GLO B2)

**SPECIFIC LEARNING OUTCOME**

**S4P-2-5: Solve problems for the escape velocity of a spacecraft.**

Include: Law of Conservation of Energy, binding energy



**SUGGESTIONS FOR INSTRUCTION**

**Entry Level Knowledge**

Conservation of energy problems are introduced in Topic 1.

**Notes to the Teacher**

If you throw an object straight up, it will rise as the acceleration of gravity slows it down and then returns it to Earth. The energy as the object leaves your hand is all kinetic energy. As the object rises, it slows down, the kinetic energy decreases, and the potential energy increases. At the maximum height, the potential energy reaches a maximum and the kinetic energy is zero. At every point, the total energy is a constant and  $E_T = E_g + E_k$ . Since the gravitational force decreases as the separation between the object and the Earth increases, there will be some point at which gravity is not strong enough to pull the object back to Earth. The gravitational binding energy of any mass is the amount of energy it needs to escape the effects of the Earth's gravitational field. On the surface of the Earth the gravitational binding energy is

$$E_g = \frac{GMm}{r}$$

where  $m$  is the mass of the object,  $M$  is mass of the Earth,  $G$  is the gravitational constant, and  $r$  is the radius of the Earth. **Escape velocity** is defined as the minimum velocity an object must have to escape the gravitational field of the Earth. That is, we must supply enough kinetic energy to overcome the gravitational binding energy.

Thus,

$$\frac{1}{2}mv^2 = \frac{GMm}{r}$$

and the escape velocity is

$$v = \sqrt{\frac{2GM}{r}}$$

Near the surface of the Earth, the escape velocity is about 11 km/s. Note that the escape velocity is independent of the mass of the object; however, rockets of larger mass will require more fuel to achieve this velocity.

An object that has this velocity at the surface of the Earth will totally escape the Earth's gravitational field (ignoring the losses due to the atmosphere). Although you can escape the Earth at this speed, the Sun also exerts an attraction on the satellite and additional energy is required to escape the solar system.

**Math Connection**

Students use a spreadsheet to calculate and record binding energies at various altitudes above the surface of the Earth. Graph the results.



**SKILLS AND ATTITUDES OUTCOME**

**S4P-0-2g:** Develop mathematical models involving linear, power, and/or inverse relationships among variables.

**GENERAL LEARNING OUTCOME CONNECTION**

*Students will...*

Understand the composition of the universe, the interactions within it, and the impacts of humankind's continued attempts to understand and explore it (GLO D6)

**SUGGESTIONS FOR INSTRUCTION**

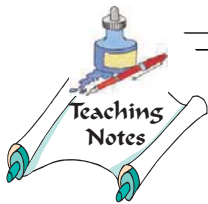

**SUGGESTIONS FOR ASSESSMENT**

**Pencil-and-Paper Tasks**

Students solve problems to find escape velocity for different orbits around the Earth.

Students solve problems to calculate escape velocity for different planets and the Moon.

**SUGGESTED LEARNING RESOURCES**

Reference: pp. 230–235, *Physics 12*, McGraw-Hill Ryerson, 2003

pp. 230–235, *Nelson Physics 12*, Thomson Nelson, 2003

pp. 207–211, *Conceptual Physics*, Pearson, 2002



NOTES





---

## TOPIC 2.2: LOW EARTH ORBIT

- S4P-2-6 Compare the Law of Universal Gravitation with the weight (mg) of an object at various distances from the surface of the Earth and describe the gravitational field as  $g = \frac{Gm_{\text{Earth}}}{r^2}$ .
- S4P-2-7 Outline Newton's thought experiment regarding how an artificial satellite can be made to orbit the earth.
- S4P-2-8 Use the Law of Universal Gravitation and circular motion to calculate the characteristics of the motion of a satellite.  
Include: orbital period, speed, altitude above a planetary surface, mass of the central body, and the location of geosynchronous satellites
- S4P-2-9 Define microgravity as an environment in which the apparent weight of a system is smaller than its actual weight.
- S4P-2-10 Describe conditions under which microgravity can be produced.  
*Examples: jumping off a diving board, roller-coaster, free fall, parabolic flight, orbiting spacecraft*
- S4P-2-11 Outline the factors involved in the re-entry of an object into Earth's atmosphere.  
Include: friction and g-forces
- S4P-2-12 Describe qualitatively some of the technological challenges to exploring deep space.  
*Examples: communication, flyby and the "slingshot" effect, Hohmann Transfer orbits (least-energy orbits)*
-

**GENERAL LEARNING OUTCOME CONNECTION**

*Students will...*

Understand the composition of the universe, the interactions within it, and the impacts of humankind's continued attempts to understand and explore it (GLO D6)

**SPECIFIC LEARNING OUTCOME**

**S4P-2-6: Compare the Law of Universal Gravitation with the weight (mg) of an object at various distances from the surface of the Earth and describe the gravitational field as**

$$g = \frac{Gm_{\text{Earth}}}{r^2}.$$



**SUGGESTIONS FOR INSTRUCTION**

**Entry Level Knowledge**

Newton's Law of Universal Gravitation was covered in the previous topic. The strength of Earth's gravitational field was represented in Senior 3 Physics as the force per unit mass.

**Notes to the Teacher**

We know that the force of gravity on an object near the surface of the Earth is  $F_g = mg$ .

The concept of the gravitational field constants is often misunderstood. In general, the strength of a gravitational field is the force per unit mass exerted by one mass on another nearby "test" mass (1 kg). Near the surface of the Earth, the force exerted on 1 kg of mass is 9.8 N. As long as we stay near the surface of the Earth, the field is constant. Consequently, the field near the surface is called a **local constant**. As we move away from the surface of the Earth, the force of gravity decreases and the field constant changes. We can compare the Law of Universal Gravitation with the weight (mg) of an object at various distances from the surface of the Earth to determine the value of  $g$  at any point in space.

$$F_g = F_G$$

$$mg = \frac{GMm_{\text{earth}}}{r^2}$$

and  $g = \frac{Gm_{\text{earth}}}{r^2}$

The above relation is valid not only for objects on Earth's surface, but also for objects above the Earth's surface. For objects above Earth's surface,  $r$  represents the distance from an object to the Earth's centre and, except for objects close to Earth's surface,  $g$  is not 9.8 N/kg. The same equation can be used for other planets and stars by substituting the appropriate mass  $M$ .

Remember:  $g$  is local,  $G$  is universal.

**Student Activity**

Is there gravity in space? A common misconception is that there is no gravity in space. Students can calculate the gravitational constant ( $g$ ) at the orbit of the shuttle (500 km above the Earth) and at the orbit of geosynchronous satellites (1000 km above the Earth).



**SKILLS AND ATTITUDES OUTCOMES**

**S4P-0-2c:** Formulate operational definitions of major variables or concepts.

**S4P-0-2d:** Estimate and measure accurately using SI units.

**GENERAL LEARNING OUTCOME CONNECTION**

*Students will...*

Describe and appreciate how the natural and constructed worlds are made up of systems and how interactions take place within and among these systems (GLO E2)

**SUGGESTIONS FOR INSTRUCTION**

**SUGGESTIONS FOR ASSESSMENT**

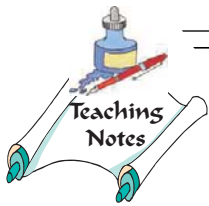

A large empty rectangular box for providing suggestions for instruction.

**Pencil-and-Paper Tasks**

Students solve problems to calculate the value of the local  $g$  for different locations (top of a mountain, equator versus the poles, on the moon, or on another planet).

Students use compare and contrast frames (SYSTH) to differentiate between the universal gravitational constant  $G$  and the local constant  $g$ .



**GENERAL LEARNING OUTCOME CONNECTION**

*Students will...*

Identify and appreciate contributions made by women and men from many societies and cultural backgrounds toward increasing our understanding of the world and in bringing about technological innovations (GLO A4)

**SPECIFIC LEARNING OUTCOME**

**S4P-2-7: Outline Newton’s thought experiment regarding how an artificial satellite can be made to orbit the Earth.**



**SUGGESTIONS FOR INSTRUCTION**

**Notes to the Teacher**

This topic is intended to capture the student’s imagination with a current topic in physics. Earth’s artificial satellites, space probes, and planetary exploration are widely reported in the media. Challenge students to answer the question, What is a satellite and how do we get one in space?

Newton thought of a satellite as a projectile that could orbit the Earth (even though he couldn’t launch one).

**Prior Knowledge Activity**

Students complete a KWL or rotational graffiti (SYSTH) chart for projectiles and satellites. Some questions might be:

- What happens as we increase the speed of a projectile that is launched horizontally?
- Can a projectile orbit the Earth?
- Wouldn’t a projectile fall toward the Earth?
- How fast is a satellite moving?
- Will satellites eventually fall to the Earth?
- How high are satellites in their orbit?
- Is their gravity in space?
- Does friction slow down a satellite?

**Newton’s Thought Experiment (horizontal projectile)**

Newton imagined a tall mountain above the surface of the Earth and asked himself, What if a powerful cannon, mounted on top of a mountain, fired cannonballs parallel to the ground? Newton knew that gravity would act on the fired cannonball, pulling it to the ground, but he considered how faster and faster cannonballs would go further and further. Eventually, he surmised that if a cannonball were fired with sufficient velocity, it would fall around the entire Earth.

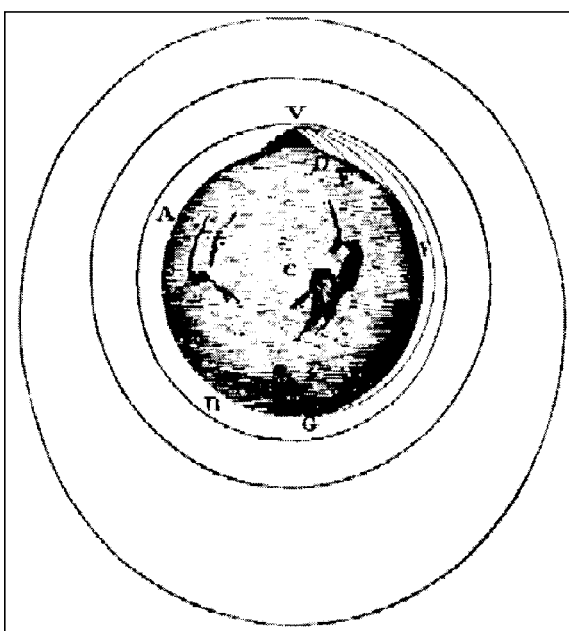

**SKILLS AND ATTITUDES OUTCOME**

**S4P-0-1c:** Relate the historical development of scientific ideas and technology to the form and function of scientific knowledge today.

**GENERAL LEARNING OUTCOME CONNECTION**

*Students will...*

Describe scientific and technological developments, past and present, and appreciate their impact on individuals, societies, and the environment, both locally and globally (GLO B1)

**SUGGESTIONS FOR INSTRUCTION**

**Class Discussion**

Earth satellites orbit high above the atmosphere, such that their motion is mostly unrestricted by forces of air resistance. Satellites are projectiles in the sense that only the force of gravity is acting on the satellite. Without a force of gravity, a satellite would continue in a straight-line path tangent to the Earth (Law of Inertia). Indeed, a satellite does fall towards the Earth; it just never falls into the Earth. Remember that the Earth is not flat, it is round and curves about 5 metres downward every 8 kilometres. Therefore, in order for a satellite to orbit the Earth, it must travel a horizontal distance of 8000 metres before falling a vertical distance of 5 metres.

How far will a horizontally launched projectile fall in its first second of motion (from Topic 1.4)?



**SUGGESTIONS FOR ASSESSMENT**

**Pencil-and-Paper Tasks**

Students solve problems to calculate the range of a projectile at various speeds.

**SUGGESTED LEARNING RESOURCES**

Many Java applets can be found on the Internet, which permit the user to control the speed of a projectile and launch it into orbit. Google “projectile java” or “satellite orbits java.”



**GENERAL LEARNING OUTCOME CONNECTION**

*Students will...*

Identify and appreciate contributions made by women and men from many societies and cultural backgrounds toward increasing our understanding of the world and in bringing about technological innovations (GLO A4)

**SPECIFIC LEARNING OUTCOME**



**S4P-2-7: Outline Newton’s thought experiment regarding how an artificial satellite can be made to orbit the Earth.**

**SUGGESTIONS FOR INSTRUCTION**

$$\Delta d_y = v_y \Delta t + \frac{1}{2} a \Delta t^2$$

Since  $v_y = 0$

$$\Delta d = \frac{1}{2} (10) (1^2)$$

$\Delta d = 5$  metres

Therefore, when a projectile is launched with a horizontal speed of 8000 m/s, the projectile will fall toward the Earth with a trajectory that matches the curvature of the Earth. Consequently, the projectile “falls” around the Earth, always accelerating towards the Earth under the influence of gravity, yet never colliding into the Earth since the Earth curves at the same rate. Such a projectile becomes an orbiting satellite.

**Demonstration**

See demonstration in Topic 1.6.



**SKILLS AND ATTITUDES OUTCOME**

**S4P-0-1c:** Relate the historical development of scientific ideas and technology to the form and function of scientific knowledge today.

**GENERAL LEARNING OUTCOME CONNECTION**

*Students will...*

Describe scientific and technological developments, past and present, and appreciate their impact on individuals, societies, and the environment, both locally and globally (GLO B1)

**SUGGESTIONS FOR INSTRUCTION**

**SUGGESTIONS FOR ASSESSMENT**

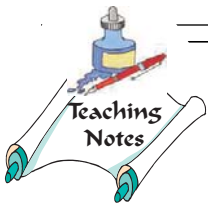

Large empty rectangular box for writing suggestions for instruction.

Large empty rectangular box for writing suggestions for assessment.



**GENERAL LEARNING OUTCOME CONNECTION**

*Students will...*

Recognize that scientific knowledge is based on evidence, models, and explanations, and evolves as new evidence appears and new conceptualizations develop (GLO A2)

**SPECIFIC LEARNING OUTCOME**



**S4P-2-8: Use the Law of Universal Gravitation and circular motion to calculate the characteristics of the motion of a satellite.**

Include: orbital period, speed, altitude above a planetary surface, mass of the central body, and the location of geosynchronous satellites

**SUGGESTIONS FOR INSTRUCTION**

**Entry Level Knowledge**

Circular motion and the Law of Universal Gravitation have been covered in Topic 1. These laws are now applied to the case of satellite motion.

**Notes to the Teacher**

Most satellites are either in a circular or near-circular orbit. The force of gravity acts as a centripetal force, holding each satellite in its own unique orbit. Therefore

$$F_{\text{gravity}} = F_{\text{centripetal}}$$

$$\frac{Gm_E m_S}{R^2} = \frac{m_S v_S^2}{R^2}$$

where  $m_E$  is the mass of the Earth,  $m_S$  is the mass of the satellite, and  $R$  is the separation between the Earth and the satellite (i.e., the radius of the Earth plus the height of the satellite above the surface of the Earth). From this comparison it is easy to calculate the speed, mass, and altitude ( $R = R_{\text{earth}} + h$ ). The period of the satellite can be found from other characteristics of circular motion such as

$$a = \frac{4\pi^2 R}{T^2} \text{ and } v = \frac{2\pi R}{T}$$

A satellite in geosynchronous orbit stays the same point above the surface of the Earth as the Earth rotates. Therefore, the period of an object in geosynchronous orbit is 24 hours. From this information, it is easy to calculate the other unknowns.





**SKILLS AND ATTITUDES OUTCOMES**

**S4P-0-1e:** Differentiate between how scientific theories explain natural phenomena and how scientific laws identify regularities and patterns in nature.

**S4P-0-2g:** Develop mathematical models involving linear, power, and/or inverse relationships among variables.

**GENERAL LEARNING OUTCOME CONNECTION**

*Students will...*

Understand the composition of the universe, the interactions within it, and the impacts of humankind's continued attempts to understand and explore it (GLO D6)

**SUGGESTIONS FOR INSTRUCTION**

**SUGGESTIONS FOR ASSESSMENT**

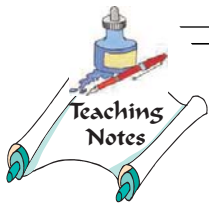

Empty box for teaching suggestions.

Students use process notes (SYSTH) to outline the steps to solve for different characteristics of satellite motion.

**Pencil-and-Paper Tasks**

Students solve problems to find various characteristics of satellite motion.

**SUGGESTED LEARNING RESOURCES**

Reference: p. 236, *Physics 12*, McGraw-Hill Ryerson, 2003



**GENERAL LEARNING OUTCOME CONNECTION**

*Students will...*

Distinguish critically between science and technology in terms of their respective contexts, goals, methods, products, and values (GLO A3)

**SPECIFIC LEARNING OUTCOMES**



**S4P-2-9: Define microgravity as an environment in which the apparent weight of a system is smaller than its actual weight.**

**S4P-2-10: Describe conditions under which microgravity can be produced.**

*Examples: jumping off a diving board, roller-coaster, free fall, parabolic flight, orbiting spacecraft*

**SUGGESTIONS FOR INSTRUCTION**

**Entry Level Knowledge**

Apparent weight in a moving elevator was covered in Senior 3 Physics.

**Notes to the Teacher**

Gravity is a force that governs motion throughout the universe. Gravity holds us to the Earth, keeps the Moon and satellites in orbit around the Earth, and the Earth in orbit around the Sun. Students often believe that there is no gravity above the Earth's atmosphere (i.e., "in space") since astronauts "float" aboard the space shuttle. A typical orbital altitude of a shuttle is about 500 km above the surface of the Earth and the gravitational field constant at this altitude can easily be calculated as described in learning outcome S4P-2-6.

$$mg = \frac{GMm}{R^2}$$

$$g = \frac{GM}{R^2}$$

$$g = \frac{6.67 \times 10^{-11} (5.98 \times 10^{24})}{(6.38 \times 10^6)^2}$$

$$g = 8.7 \text{ N/kg}$$

The gravitational field 500 km above the surface of the Earth is about 89% of its strength at the surface of the Earth!

**Microgravity** occurs when the apparent weight of an object is small compared to its actual weight. Any object in free fall experiences microgravity conditions. As the object falls toward the Earth, its acceleration is equal to that due to gravity alone, and the apparent weight of the object is near zero.

**Class Discussion**

Begin by discussing the elevator problems from Senior 3 Physics. Imagine riding an elevator to the top floor of a building. The force that the floor of the elevator exerts on you is your apparent weight. The total force acting on you is the force of gravity plus the force of the elevator. In this case, your apparent weight is due to the acceleration of the elevator ( $F_e = ma_e$ ) minus the force of gravity ( $F_g = mg$ ). That is,

$$\text{Apparent Weight } (W) = F_e - F_g$$

$$W = ma_e - ma_g$$

$$W = m(a_e - a_g)$$

Now, imagine that the elevator cables have been cut and the elevator is falling freely. Since the elevator will fall with an acceleration of  $g$  (i.e.,  $a_e = a_g$ ), your apparent weight is zero and you are "weightless" even though you are still in a gravitational field.



**SKILLS AND ATTITUDES OUTCOMES**

**S4P-0-2c:** Formulate operational definitions of major variables or concepts.

**S4P-0-4c:** Demonstrate confidence in their ability to carry out investigations in science and to address STSE issues.

**S4P-0-4e:** Demonstrate a continuing and more informed interest in science and science-related issues.

**GENERAL LEARNING OUTCOME CONNECTION**

*Students will...*

Describe and appreciate how the natural and constructed worlds are made up of systems and how interactions take place within and among these systems (GLO E2)

**SUGGESTIONS FOR INSTRUCTION**

Spacecraft orbiting the Earth follow a trajectory such that the craft is always falling toward the Earth in a path parallel to the curvature of the Earth. Consequently, a microgravity environment is established. Remember that the spacecraft is not falling toward the Earth, it is falling around the Earth. However, since all objects in the space shuttle are falling at the same rate, objects inside the shuttle appear to float in a state we call microgravity.

The apparent weightlessness of free fall has not always been well known. Albert Einstein commented

*“I was sitting in a chair in the patent office at Bern when all of a sudden a thought occurred to me: if a person falls freely, he will not feel his own weight. I was startled.”*

Microgravity can be created in several different ways. First of all, we could venture into deep outer space such that the Earth’s gravitational field is effectively zero. However, we would need to travel millions of kilometres away from the Earth. Another way to achieve microgravity, as we have already noted, is with free fall. We can experience microgravity for a short period of time in activities such as diving off a board or in sensations experienced in free-fall rides in amusement parks. In this situation, microgravity is only experienced for a short period of time. Drop facilities are used to create a microgravity environment for a longer period of time. The NASA Lewis Center has a

**SUGGESTIONS FOR ASSESSMENT**

**Pencil-and-Paper Tasks**

Students calculate the apparent weight for different accelerations.

**Research/Report**

Students research and report on microgravity experiments in space and on Earth.

**SUGGESTED LEARNING RESOURCES**

NASA’s Teachers Guide for microgravity is an invaluable resource for this topic. The guide includes many student activities, is accessibly written, and is quite comprehensive. It can be found in pdf form and downloaded at:

<<http://spacelink.nasa.gov/Instructional.Materials/NASA.Educational.Products/Microgravity/>>

Many more space science-related teacher-developed materials can be freely accessed at:

<<http://spacelink.nasa.gov/Instructional.Materials/NASA.Educational.Products/.index.html#EG>>



**GENERAL LEARNING OUTCOME CONNECTION**

*Students will...*

Distinguish critically between science and technology in terms of their respective contexts, goals, methods, products, and values (GLO A3)

**SPECIFIC LEARNING OUTCOMES**



**S4P-2-9: Define microgravity as an environment in which the apparent weight of a system is smaller than its actual weight.**

**S4P-2-10: Describe conditions under which microgravity can be produced.**

*Examples: jumping off a diving board, roller-coaster, free fall, parabolic flight, orbiting spacecraft*

**SUGGESTIONS FOR INSTRUCTION**

132-metre drop facility, which is similar to a very long mine shaft. Microgravity can be achieved for a period of about five seconds. The longest drop time currently available is in a 490-metre mine shaft in Japan.

Airplanes can achieve a microgravity environment for about 20 seconds if the plane flies in a parabolic path. During the “nose high” and “nose low” phases, accelerations of up to 2 g are experienced. However, during the “pull up” phase (zero g in the diagram), the acceleration will closely match the acceleration due to gravity, and weightlessness will be experienced. These flights are used as astronaut training exercises, which the astronauts lovingly refer to as the “vomit comet.” The effect is similar to traversing a hill on a roller-coaster ride.

In the movie *Apollo 13* (1995), the producers were actually allowed to use NASA’s “anti-gravity” aircraft KC-135 to film the sequence in which the actors seem to be floating around the cabin. The aircraft first reaches an altitude of 30,000 feet (use 10,000 m as an approximation) with a speed of near Mach 1 (300 m/s is an approximation). The aircraft then descends, following roughly a parabolic curve, ascends again, and is able to complete many cycles. The people inside are actually in free fall for 23 seconds for each descending part of the cycle. A typical flight may last several hours, involving as many as 40 short periods of free fall, allowing crew members to do their experiments.

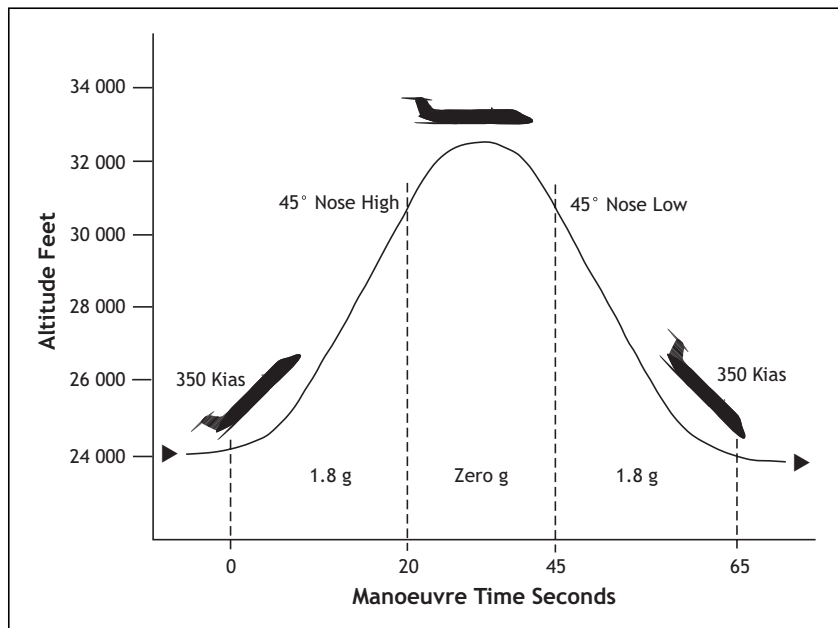

**SKILLS AND ATTITUDES OUTCOMES**

**S4P-0-2c:** Formulate operational definitions of major variables or concepts.

**S4P-0-4c:** Demonstrate confidence in their ability to carry out investigations in science and to address STSE issues.

**S4P-0-4e:** Demonstrate a continuing and more informed interest in science and science-related issues.

**GENERAL LEARNING OUTCOME CONNECTION**

*Students will...*

Describe and appreciate how the natural and constructed worlds are made up of systems and how interactions take place within and among these systems (GLO E2)

**SUGGESTIONS FOR INSTRUCTION**

**SUGGESTIONS FOR ASSESSMENT**

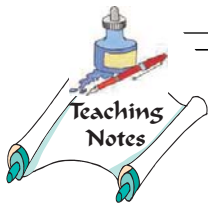

A large, empty rectangular box intended for writing suggestions for instruction.

A large, empty rectangular box intended for writing suggestions for assessment.



**GENERAL LEARNING OUTCOME CONNECTION**

*Students will...*

Recognize that scientific and technological endeavours have been and continue to be influenced by human needs and the societal context of the time (GLO B2)

**SPECIFIC LEARNING OUTCOME**



**S4P-2-11: Outline the factors involved in the re-entry of an object into Earth's atmosphere.**

Include: friction and g-forces

---

**SUGGESTIONS FOR INSTRUCTION**

**Entry Level Knowledge**

Friction has previously been discussed in Senior 3 Physics and in Topic 1.

**Notes to the Teacher**

The density of Earth's atmosphere depends on the altitude above the surface of the Earth. In low Earth orbit the sparse friction of the atmosphere will slow a satellite over time and cause the satellite to fall to a lower orbit and eventually re-enter Earth's atmosphere. As the satellite, or a spacecraft on re-entry, falls toward Earth, the density of the atmosphere increases. The heat that the satellite creates is not only due to the frictional effects but also due to a pressure wave that is created in front of the spacecraft as it moves at high speeds into the atmosphere. As the pressure increases, the temperature must also increase. Burning up of a satellite on re-entry is minimized by heat-resistive tiles that cover the spacecraft. These tiles must have an extremely low thermal conductivity.

As a consequence of re-entry, several problems arise:

- If the angle of re-entry is too shallow at the point where the effects of atmospheric density are significant (about 120 km), the spacecraft will bounce off the atmosphere and be propelled back into space.
- If the angle is too steep, the spacecraft will descend too quickly and the *g* forces and heat build-up will be unmanageable.
- In any case, astronauts in the spacecraft must be protected from the extreme heat build-up. A blunt nose and specially designed protective surfaces (heat tiles) are used to protect the occupants.
- The extreme heat generates a layer of ionizing particles, which prevents radio communication for a period of time.



**SKILLS AND ATTITUDES OUTCOMES**

**S3P-0-3a:** Analyze, from a variety of perspectives, the risks and benefits to society and the environment when applying scientific knowledge or introducing technology.

**S3P-0-4e:** Demonstrate a continuing and more informed interest in science and science-related issues.

**GENERAL LEARNING OUTCOME CONNECTION**

*Students will...*

Understand how stability, motion, forces, and energy transfers and transformations play a role in a wide range of natural and constructed contexts (GLO D4)

**SUGGESTIONS FOR INSTRUCTION**

**SUGGESTIONS FOR ASSESSMENT**

**Interpretation of Media Reports of Science**

Re-entries of shuttle missions are extensively covered in the media. Students can review a newspaper article, or other media report, and evaluate the accuracy of the physics of re-entry.

**SUGGESTED LEARNING RESOURCES**

See the site maintained by Dr. David Morrison, *Asteroid and Comet Impact Hazards*:

**Synopsis:** The Earth orbits the Sun in a sort of cosmic shooting gallery, subject to impacts from comets and asteroids. It is only fairly recently that we have come to appreciate that these impacts by asteroids and comets (often called Near Earth Objects, or NEOs) pose a significant hazard to life and property. Although the annual probability of the Earth's being struck by a large asteroid or comet is extremely small, the consequences of such a collision are so catastrophic that it is prudent to assess the nature of the threat and prepare to deal with it.

<<http://impact.arc.nasa.gov/index.html>>

**SUGGESTED LEARNING RESOURCES**

Metz, D., and A Stinner, "Deep Impact: The Physics of Earth-Asteroid Collisions," *The Physics Teacher* 40 (2002): 487–492.

**Internet**

Metz and Stinner (see above) also maintain an interactive website related to the dynamics of asteroidal impacts. Students can alter the parameters of an impact event (e.g., size and composition of the impactor) and model what the results might be (e.g., crater size, ejecta distribution area, etc.).

The Physics of Earth-Asteroid Impacts  
<<http://io.uwinnipeg.ca/~metz/asteroids.html>>



**GENERAL LEARNING OUTCOME CONNECTION**

Students will...

Recognize that science and technology interact with and advance one another (GLO A5)

**SPECIFIC LEARNING OUTCOME**



**S4P-2-12: Describe qualitatively some of the technological challenges to exploring deep space.**

*Examples: communication, flyby and the “slingshot” effect, Hohmann Transfer (least-energy orbits)*

**SUGGESTIONS FOR INSTRUCTION**

**Entry Level Knowledge**

Relative velocity was addressed in Topic 1.

**Notes to the Teacher**

Space explorers face several interesting problems as they probe deep space. A few examples are described but teachers and students are encouraged to investigate other technological challenges of space travel they find interesting.

Ask students to brainstorm how they would communicate with a satellite probe.

- How does it take and store a picture?
- How does it send the picture?
- How do we receive the picture on a rotating Earth?

These are all obstacles to consider. Students can investigate NASA’s deep space network at: <http://deepspace.jpl.nasa.gov/ds.>>

**Class Discussion: Gravity Assist**

The energy for a space vehicle to escape the gravitational attraction of the Earth comes from the chemical propulsion of the rocket booster. However, chemical rockets have limitations if we want to send spacecraft beyond the Moon. Even to go to Mars, the next logical destination in space, a spacecraft would require so much fuel that large amounts would have to be produced on the planet for the return trip. Consequently, spacecraft

intended for the outer reaches of the solar system must use a more natural means to accelerate into space.

The slingshot effect or “gravity assist” involves conservation of momentum and energy along with the relative velocity of the space probe to the Sun. First, consider the simple analogy of bouncing a marble off a bowling ball. If the bowling ball is still and you throw a marble at it 5 km/h, the marble rebounds at 5 km/h (ideally). If the bowling ball is moving toward you at 30 km/h, from the frame of reference of the bowling ball, the marble comes toward it at  $30 + 5 = 35$  km/h, and it rebounds off at 35 km/h. The momentum of the marble increases while the bowling ball loses a little momentum. However, since the mass of the bowling ball is much greater than the marble, its change in momentum is minute. A gravitational interaction with a planet is just like bouncing off of it. However, the interaction is not a head-on collision but a “glancing” blow.

As a probe approaches a planet, its velocity with respect to the Sun is equal to the vector sum of its velocity with respect to the planet and the velocity of the planet with respect to the Sun. The magnitudes of the approach and departure velocities with respect to the planet are equal, but the direction of the departure velocity is changed by the gravitational attraction of the planet. In effect, the trajectory is bent.





**SKILLS AND ATTITUDES OUTCOME**

**S4P-0-3b:** Describe examples of how technology has evolved in response to scientific advances, and how scientific knowledge has evolved as the result of new innovations in technology.

**GENERAL LEARNING OUTCOME CONNECTION**

*Students will...*

Recognize that scientific and technological endeavours have been and continue to be influenced by human needs and the societal context of the time (GLO B2)

**SUGGESTIONS FOR INSTRUCTION**

**SUGGESTIONS FOR ASSESSMENT**

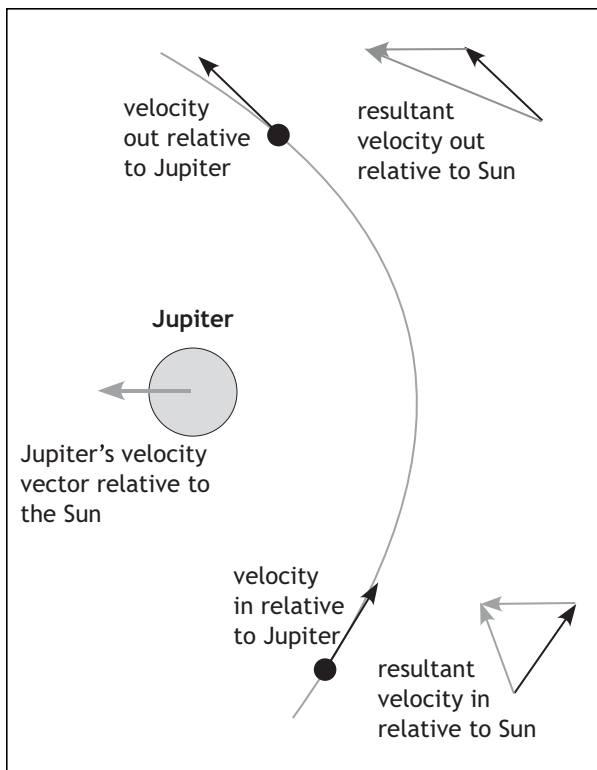

As the probe leaves the planet, its velocity with respect to the Sun has changed because the vector sum of its velocity with respect to the planet and the planet's velocity has changed. The vector diagram of the relative velocities helps to clarify the situation. On approach, the planet moves with a constant velocity  $V$  and the probe has a velocity  $v$  (relative to the planet). Since the direction of the velocity vector is changed, the velocity of the probe relative to the Sun increases.

**Pencil-and-Paper Tasks**

Students draw vector diagrams of the motion of a space probe as it passes a planet in a gravity assist.

**Gallery Walk**

Students research various technological challenges and present a multimedia gallery display.

**SUGGESTED LEARNING RESOURCES**

See orbital energies, p. 237, *Physics 12*, McGraw-Hill Ryerson, 2003

NASA website: <<http://deepspace.jpl.nasa.gov/dsn/>>

Stinner, A., "Hitchhiking On An Asteroid: A Large Context Problem," *Physics in Canada* (Jan/Feb. 2000): 27–42.

Hohmann Transfer Orbits:

<<http://www.astronomynotes.com/gravappl/s9.htm>>

<[http://liftoff.msfc.nasa.gov/academy/rocket\\_sci/satellites/hohmann.html](http://liftoff.msfc.nasa.gov/academy/rocket_sci/satellites/hohmann.html)>



**GENERAL LEARNING OUTCOME CONNECTION**

*Students will...*

Recognize that science and technology interact with and advance one another (GLO A5)

**SPECIFIC LEARNING OUTCOME**



**S4P-2-12: Describe qualitatively some of the technological challenges to exploring deep space.**

*Examples: communication, flyby and the “slingshot” effect, Hohmann Transfer (least-energy orbits)*

**SUGGESTIONS FOR INSTRUCTION**

The first spacecraft to experience a gravity assist was NASA’s Pioneer 10. In December 1973, it approached a rendezvous with Jupiter, the largest planet in the solar system, travelling at 9.8 kilometres per second. Following its passage through Jupiter’s gravitational field, it sped off into deep space at 22.4 kilometres a second—like when you let go of a spinning merry-go-round and fly off in one direction.

In October 1997, NASA launched the probe Cassini on a six-year journey to explore Saturn. The probe was launched with a speed of 4 km/s. However, Saturn is much higher up the Sun’s gravitational potential well than the Earth, and a probe requires at least 10 km/s to escape its binding energy. NASA engineers devised a trajectory such that Cassini would interact with Venus and Jupiter in a slingshot effect to propel Cassini to the outer reaches of the solar system.

**Demonstration**

Place a tennis ball on top of a basketball and let them fall together from some height (a stepladder works well). The bounce of the basketball will send the tennis ball off at very high speeds, demonstrating the result of transferring energy from a large mass to a small mass.

**Class Discussion: Hohmann Transfer Orbits (“least-energy” orbits)**

Changing a spacecraft’s orbit involves firing an engine to change the magnitude or the direction of the spacecraft’s velocity. Remember that if the spacecraft’s velocity increases, there is a corresponding increase in the radius of orbit. Firing a spacecraft’s engine requires fuel so the path that requires the least amount of burn is critical in space manoeuvres. A Hohmann Transfer is a fuel-efficient way to transfer from one orbit to another that is in the same plane. To change from a lower orbit to a higher orbit, an engine is fired to add velocity to the vehicle. When the desired orbit is achieved, the engine is fired again to slow the spacecraft into a stable orbit. Hohmann found that the most efficient path of transfer is an ellipse that is tangent to both orbits. Hohmann Transfer orbits are used to travel to Mars, and therefore the Earth and Mars must be aligned properly for the transfer. This explains why only certain “windows” of time are permitted for deep space exploration.



**SKILLS AND ATTITUDES OUTCOME**

**S4P-0-3b:** Describe examples of how technology has evolved in response to scientific advances, and how scientific knowledge has evolved as the result of new innovations in technology.

**GENERAL LEARNING OUTCOME CONNECTION**

*Students will...*

Recognize that scientific and technological endeavours have been and continue to be influenced by human needs and the societal context of the time (GLO B2)

**SUGGESTIONS FOR INSTRUCTION**

**SUGGESTIONS FOR ASSESSMENT**

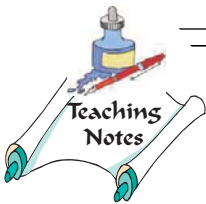

NOTES



---

## **TOPIC 2.3: ELECTRIC AND MAGNETIC FIELDS**

- S4P-2-13 Compare and contrast the inverse square nature of gravitational and electric fields.
- S4P-2-14 State Coulomb's Law and solve problems for more than one electric force acting on a charge.  
Include: one and two dimensions
- S4P-2-15 Illustrate, using diagrams, how the charge distribution on two oppositely charged parallel plates results in a uniform field.
- S4P-2-16 Derive an equation for the electric potential energy between two oppositely charged parallel plates ( $E_e = qE\Delta d$ ).
- S4P-2-17 Describe electric potential as the electric potential energy per unit charge.
- S4P-2-18 Identify the unit of electric potential as the volt.
- S4P-2-19 Define electric potential difference (voltage) and express the electric field between two oppositely charged parallel plates in terms of voltage and the separation between the plates  $\left(\varepsilon = \frac{\Delta V}{d}\right)$ .
- S4P-2-20 Solve problems for charges moving between or through parallel plates.
- S4P-2-21 Use hand rules to describe the directional relationships between electric and magnetic fields and moving charges.
- S4P-2-22 Describe qualitatively various technologies that use electric and magnetic fields.  
*Examples: electromagnetic devices (such as a solenoid, motor, bell, or relay), cathode ray tube, mass spectrometer, antenna*
-

**GENERAL LEARNING OUTCOME CONNECTION**

*Students will...*

Describe and appreciate the similarity and diversity of forms, functions, and patterns within the natural and constructed world (GLO E1)

**SPECIFIC LEARNING OUTCOME**



**S4P-2-13: Compare and contrast the inverse square nature of gravitational and electric fields.**

**SUGGESTIONS FOR INSTRUCTION**

**Entry Level Knowledge**

The definition of gravitational fields around a point mass

$$\left( g = \frac{F_g}{m} \right)$$

and the diagram of the Earth's gravitational field have been introduced in Senior 3 Physics.

Also introduced were the corresponding definition of the electric field

$$\left( E = \frac{F_e}{q} \right)$$

and diagrams of electric fields around positive and negative charges.

The inverse square nature of the gravitational field for a mass

$$\left( g = \frac{Gm}{r^2} \right)$$

was examined in Topic 2.2.

**Notes to the Teacher**

When examining the gravitational field of a mass, it is useful to view the mass as a point mass, irrespective of its size. Similar treatment is given to electric charges. The electric and gravitational field diagrams are similar. Both fields exhibit an inverse square relationship with respect to the field strength versus the distance from the centre of the object. However, unlike gravitational fields, which are always attractive, electric fields can be repulsive as well. The formula for the electric field around a point charge

$$\left( E = \frac{kq}{r^2} \right)$$

can be expressed by analogy with gravitational fields. In this learning outcome, it is sufficient to compare and contrast the fields.



**SKILLS AND ATTITUDES OUTCOMES**

**S4P-0-2c:** Formulate operational definitions of major variables or concepts.

**S4P-0-2g:** Develop mathematical models involving linear, power, and/or inverse relationships among variables.

**GENERAL LEARNING OUTCOME CONNECTION**

*Students will...*

Describe and appreciate the similarity and diversity of forms, functions, and patterns within the natural and constructed world (GLO E1)

**SUGGESTIONS FOR INSTRUCTION**

**SUGGESTIONS FOR ASSESSMENT**

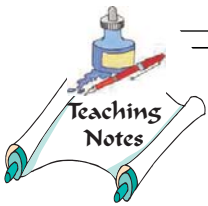

Students use compare and contrast frames (SYSTH) for gravitational and electric fields.



**GENERAL LEARNING OUTCOME CONNECTION**

*Students will...*

Understand the composition of the universe, the interactions within it, and the impacts of humankind's continued attempts to understand and explore it (GLO D6)

**SPECIFIC LEARNING OUTCOME**



**S4P-2-14: State Coulomb's Law and solve problems for more than one electric force acting on a charge.**

Include: one and two dimensions

**SUGGESTIONS FOR INSTRUCTION**

**Entry Level Knowledge**

The inverse square nature of the electric field of a point charge was introduced in the previous learning outcome, and the relationship between force on a charge in an electric field,

$$\left( E = \frac{F}{q} \right),$$

was introduced in Senior 3 Physics.

**Notes to the Teacher**

Coulomb believed that the force between electric charges would follow an inverse square relationship paralleling Newton's Law of Universal Gravitation, and he verified it experimentally. That is, it follows from the Law of Universal

Gravitation that  $F_g \propto q_1 q_2$  and  $F_g \propto \frac{1}{R^2}$ .

**Laboratory Activity**

Students use Coulomb's Law apparatus (a pith sphere that is repelled by a nearby, identical pith

sphere) to demonstrate that  $F_e \propto \frac{1}{R^2}$ .

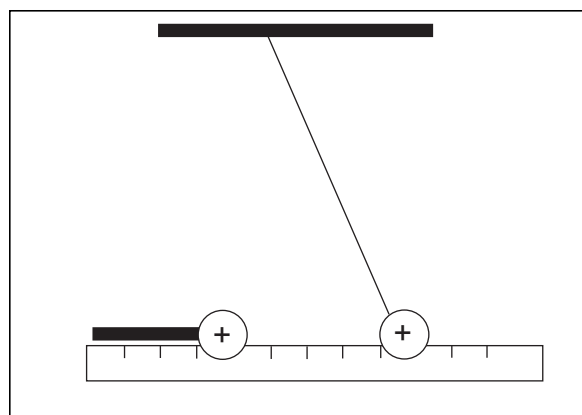

Coulomb's Experiment

**Mathematical Connection**

Another approach is to reason that one can imagine a concentric sphere enclosing the charge at a specified radius. Noting that the number of field lines is constant and equally spread out over the sphere, it follows that the field lines will spread out as one enlarges the sphere to a new radius.

Given that the surface area of a sphere is

$$\text{Surface Area} = 4\pi r^2,$$

it can be reasoned that the field strength will fall off as an inverse square relationship. Incorporating this reasoning and combining it with

$$\left( E = \frac{F}{q} \right), \text{ one can obtain } F = \frac{kq_1 q_2}{r^2}.$$





**SKILLS AND ATTITUDES OUTCOME**

**S4P-0-2h:** Analyze problems using vectors.

Include: Adding and subtracting vectors in straight lines, at right angles, and at non-orthogonal angles

**GENERAL LEARNING OUTCOME CONNECTION**

*Students will...*

Recognize that characteristics of materials and systems can remain constant or change over time, and describe the conditions and processes involved (GLO E3)

**SUGGESTIONS FOR INSTRUCTION**
**SUGGESTIONS FOR ASSESSMENT**
**Class Activity**

When solving problems using Coulomb's Law, vector solutions should include force vectors acting at any angle in a plane.

Illustrative example: Place charges as illustrated below with  $q_A = -4.0$  nC,  $q_B = -10$  nC, and  $q_C = 6.0$  nC. Find the net force exerted on charge B.

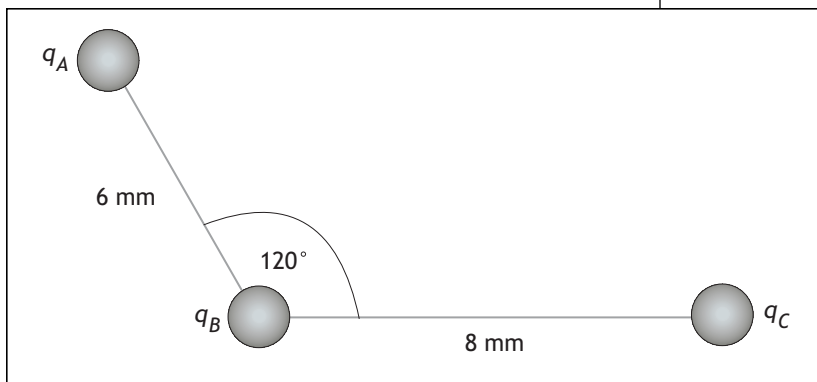
**Pencil-and-Paper Tasks**

Students solve problems using various configurations of charge.

First, we need to recognize that the force  $q_A$  exerts on  $q_C$  does not affect the force exerted on  $q_B$ . Likewise, we don't need to consider the force  $q_C$  exerts on  $q_A$ . Next, the students must make a diagram to illustrate the direction of the forces on charge B. The force between  $q_A$  and  $q_B$  is repulsive (see  $\vec{F}_{AB}$ ) and the force between  $q_C$  and  $q_B$  is attractive (see  $\vec{F}_{CB}$ ).  $\vec{F}_{AB}$  should be resolved into components as shown.



**GENERAL LEARNING OUTCOME CONNECTION**

Students will...

Understand the composition of the universe, the interactions within it, and the impacts of humankind's continued attempts to understand and explore it (GLO D6)

**SPECIFIC LEARNING OUTCOME**

**S4P-2-14: State Coulomb's Law and solve problems for more than one electric force acting on a charge.**

Include: one and two dimensions



**SUGGESTIONS FOR INSTRUCTION**

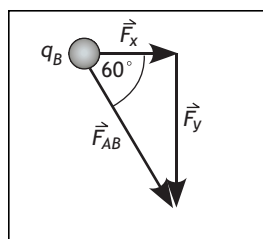
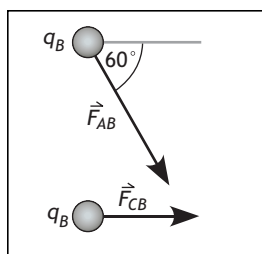

Now, find the forces.

$$F_{AB} = \frac{\left(9.0 \times 10^9 \frac{\text{N} \cdot \text{m}^2}{\text{C}^2}\right)(4.0 \times 10^{-9} \text{ C})(10 \times 10^{-9} \text{ C})}{(6.0 \times 10^{-3} \text{ m})^2}$$

$$F_{AB} = 1.00 \times 10^{-2} \text{ N } 60^\circ \text{ below the horizontal}$$

The two components for  $F_{AB}$  are:

$$\text{x-comp: } +(1.00 \times 10^{-2} \text{ N}) \cos 60 = +5.0 \times 10^{-3} \text{ N}$$

$$\text{y-comp: } +(1.00 \times 10^{-2} \text{ N}) \sin 60 = -8.7 \times 10^{-3} \text{ N}$$

$$F_{CB} = \frac{\left(9.0 \times 10^9 \frac{\text{N} \cdot \text{m}^2}{\text{C}^2}\right)(6.0 \times 10^{-9} \text{ C})(10 \times 10^{-9} \text{ C})}{(8.0 \times 10^{-3} \text{ m})^2}$$

$$= 8.4 \times 10^{-3} \text{ N}$$

$$F_{CB} = \text{only has an x:comp: } +8.4 \times 10^{-3} \text{ N}$$

The vector sum of these three components is  $1.6 \times 10^{-2} \text{ N } 33^\circ$  below the horizontal.



**SKILLS AND ATTITUDES OUTCOME**

**S4P-0-2h:** Analyze problems using vectors.

Include: Adding and subtracting vectors in straight lines, at right angles, and at non-orthogonal angles

**GENERAL LEARNING OUTCOME CONNECTION**

*Students will...*

Recognize that characteristics of materials and systems can remain constant or change over time, and describe the conditions and processes involved (GLO E3)

**SUGGESTIONS FOR INSTRUCTION**

**SUGGESTIONS FOR ASSESSMENT**

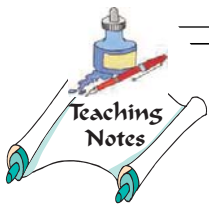

Large empty rectangular box for providing suggestions for instruction.

Large empty rectangular box for providing suggestions for assessment.



**GENERAL LEARNING OUTCOME CONNECTION**

Students will...

Employ effective communication skills and utilize information technology to gather and share scientific and technological ideas and data (GLO C6)

**SPECIFIC LEARNING OUTCOME**

**S4P-2-15: Illustrate, using diagrams, how the charge distribution on two oppositely charged parallel plates results in a uniform field.**



**SUGGESTIONS FOR INSTRUCTION**

**Entry Level Knowledge**

Students have seen the field between oppositely charged plates in Senior 3 Physics. In this learning outcome, students quantitatively determine why the field is uniform. The vector nature of the electric force was covered in the previous learning outcome.

**Notes to the Teacher**

For a parallel plate, picture a plane of positive charges on the top plate. Each charge creates an equal electric field around itself. For an even distribution of charges on a 2-D plate, there would always be an equal magnitude and opposite direction field from neighbouring charges that would cancel. In regions below and above the plane, any components of the fields parallel to the plane will cancel. Any components of the field perpendicular to the plane will increase the electric field perpendicular to the plane. For a positively charged plate, the field will point away from the plates. For a negatively charged plate, the field will point toward the plate. By placing a negative plate in parallel with a positive plate, the field between the plates will be strengthened and the fields outside the plates will experience some amount of cancellation. Note that we are disregarding the fringing effects that occur at the edges of the pair of parallel plates.

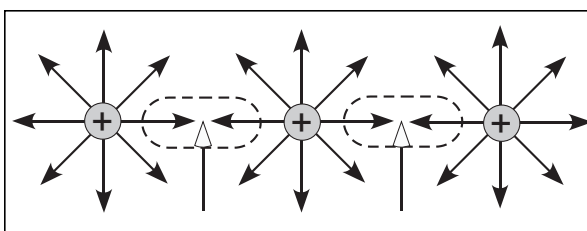

Horizontal Fields Cancel

Using Coulomb's Law and vector addition, it can be shown quantitatively that the resultant force is a constant. A productive approach is to have students complete examples as part of the previous outcome. In this way, the uniform field will be obvious.

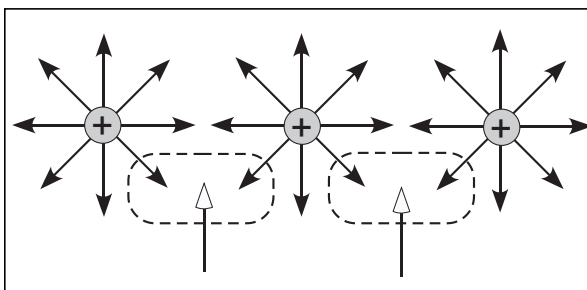

Horizontal Fields Cancel / Vertical Components Add



**SKILLS AND ATTITUDES OUTCOME**

**S4P-0-2f:** Record, organize, and display data using an appropriate format.

Include: labelled diagrams, tables, graphs

**GENERAL LEARNING OUTCOME CONNECTION**

*Students will...*

Employ effective communication skills and utilize information technology to gather and share scientific and technological ideas and data (GLO C6)

**SUGGESTIONS FOR INSTRUCTION**

**SUGGESTIONS FOR ASSESSMENT**

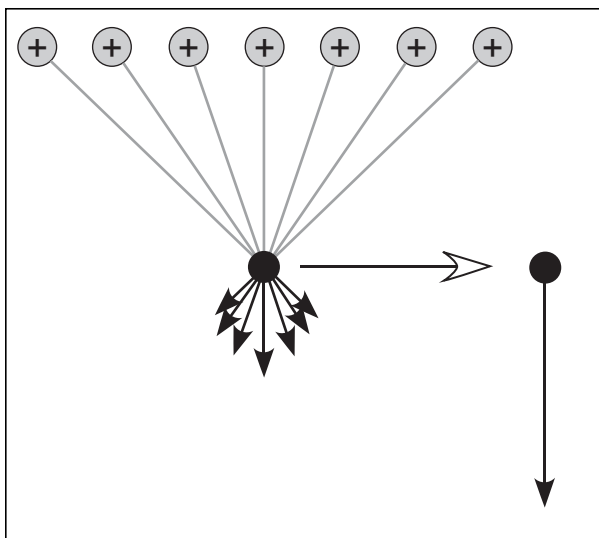

**Visual Displays**

Students sketch and correct field diagrams through a peer-review and commentary format.



**GENERAL LEARNING OUTCOME CONNECTION**

*Students will...*

Recognize that scientific knowledge is based on evidence, models, and explanations, and evolves as new evidence appears and new conceptualizations develop (GLO A2)

**SPECIFIC LEARNING OUTCOMES**

**S4P-2-16: Derive an equation for the electric potential energy between two oppositely charged parallel plates ( $E_e = qE\Delta d$ ).**

**S4P-2-17: Describe electric potential as the electric potential energy per unit charge.**

**S4P-2-18: Identify the unit of electric potential as the volt.**



**S4P-2-19: Define electric potential difference (voltage) and express the electric field between two oppositely charged parallel plates in terms of voltage and the separation between the plates  $\left( \varepsilon = \frac{\Delta V}{d} \right)$ .**

**SUGGESTIONS FOR INSTRUCTION**

**Entry Level Knowledge**

Students know that work done on an object is equal to the change in potential energy.

**Notes to the Teacher**

The field between parallel plates is examined quantitatively to introduce the idea of electric potential difference (voltage) to students. The voltage concept is later used in the analysis of circuits in Topic 3.

**Class Discussion**

If we placed a positive charge between two oppositely charged parallel plates, it would rest comfortably at the negative plate. In order to move the charge to the positive plate, we must do work (apply a force through a distance). The work done moving the charge closer to the positive plate is given by  $W = \vec{F}\Delta\vec{d}$ . Since the force on an electric charge is  $\vec{F} = q\vec{e}$ , we get  $W = (q\vec{e})\Delta\vec{d}$  where  $\vec{e}$  is the electric field vector. The work done on an object always equals the change in energy of the object ( $W = \Delta E$ ). In this case, the work done on the charge is equal to the electric potential energy gained by the charge. This is analogous to raising a mass in a gravitational field. Using  $E_e$  to represent electric potential energy, if we move the charge from a point where the initial energy is zero, the electric potential energy between the plates is  $E_e = q\vec{e}\Delta\vec{d}$ . Note that  $E_e$  is a scalar quantity. If an

outside force moves the charge against the electric force, then work will be positive and potential energy will increase. If electric force moves the charge, work will be negative and electric potential energy will decrease.

The concept of electric potential makes work and energy calculations in electric fields easier. Electric potential ( $V$ ) is the electrical potential energy per unit charge

$$\left( V = \frac{E_e}{q} \right)$$

Electric potential is a unit concept, similar to the gravitational and the electric field constants. Electric potentials are similar to elevations in gravitational fields; it is really only the change in elevation (and not the measurement from the point of zero potential) that interests us. Consequently, we usually use the electric potential difference (voltage) in our calculations.

The language of energy is very tricky and can be summarized as follows:

- Electric potential energy ( $E_e$ )—the energy between two charges
- Electric potential ( $V$ )—the electric potential energy per unit charge
- Electric potential difference ( $\Delta V$ )—the difference in electric potential between two points (as in an electric circuit)



**SKILLS AND ATTITUDES OUTCOMES**

**S4P-0-2c:** Formulate operational definitions of major variables or concepts.

**S4P-0-2d:** Estimate and measure accurately using SI units.

**S4P-0-2g:** Develop mathematical models involving linear, power, and/or inverse relationships among variables.

**GENERAL LEARNING OUTCOME CONNECTION**

*Students will...*

Understand the properties and structures of matter as well as various common manifestations and applications of the actions and interactions of matter (GLO D3)

**SUGGESTIONS FOR INSTRUCTION**

Physicists are sometimes imprecise with this language, commonly using only the term *potential*. Textbooks also often omit the Greek  $\Delta$  sign (delta = “change in”), creating even more confusion.

Since electric potential is defined as the electric potential energy per unit charge, the units would be measured in joules/coulomb. One joule per coulomb is defined as the **volt**.

The diagram illustrates the electric potential at various points between parallel plates in a manner similar to gravitational potential fields.

**SUGGESTIONS FOR ASSESSMENT**

**Observation**

Carefully monitor the correct usage of the energy terms.

**Pencil-and-Paper Tasks**

Students solve various problems to calculate the energy between parallel plates.

Students compare and contrast electric and gravitational potential energy.

Students solve various problems to calculate field between parallel plates.

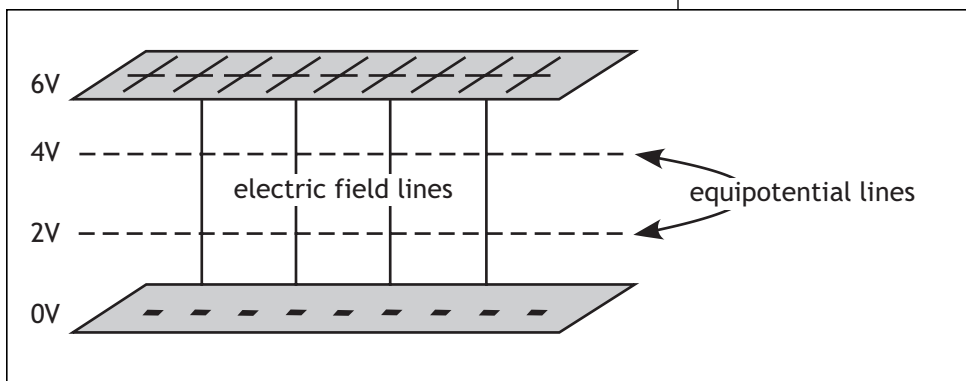

**GENERAL LEARNING OUTCOME CONNECTION**

*Students will...*

Recognize that scientific knowledge is based on evidence, models, and explanations, and evolves as new evidence appears and new conceptualizations develop (GLO A2)

**SPECIFIC LEARNING OUTCOMES**

**S4P-2-16: Derive an equation for the electric potential energy between two oppositely charged parallel plates ( $E_e = qE\Delta d$ ).**

**S4P-2-17: Describe electric potential as the electric potential energy per unit charge.**

**S4P-2-18: Identify the unit of electric potential as the volt.**



**S4P-2-19: Define electric potential difference (voltage) and express the electric field between two oppositely charged parallel plates in terms of voltage and the separation between the plates  $\left(\varepsilon = \frac{\Delta V}{d}\right)$ .**

**SUGGESTIONS FOR INSTRUCTION**

To derive the expression for the field between

parallel plates, we combine  $E_e = q\vec{\varepsilon}\Delta\vec{d}$  and  $V = \frac{E_e}{q}$ .

$$E_e = q\vec{\varepsilon}\Delta\vec{d}$$

$$\frac{E_e}{q} = \vec{\varepsilon}\Delta\vec{d}$$

$$V = \vec{\varepsilon}\Delta\vec{d}$$

$$\vec{\varepsilon} = \frac{V}{\Delta\vec{d}}$$

**Student Activity**

Students complete Three-Point Analysis frames (SYSTH) for the concepts of electric potential energy, electric potential, electric potential difference, and voltage.





**SKILLS AND ATTITUDES OUTCOMES**

**S4P-0-2c:** Formulate operational definitions of major variables or concepts.

**S4P-0-2d:** Estimate and measure accurately using SI units.

**S4P-0-2g:** Develop mathematical models involving linear, power, and/or inverse relationships among variables.

**GENERAL LEARNING OUTCOME CONNECTION**

*Students will...*

Understand the properties and structures of matter as well as various common manifestations and applications of the actions and interactions of matter (GLO D3)

**SUGGESTIONS FOR INSTRUCTION**

**SUGGESTIONS FOR ASSESSMENT**

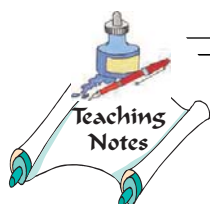

A large, empty rectangular box intended for handwritten notes under the "SUGGESTIONS FOR INSTRUCTION" header.

A large, empty rectangular box intended for handwritten notes under the "SUGGESTIONS FOR ASSESSMENT" header.



**GENERAL LEARNING OUTCOME CONNECTION**

*Students will...*

Recognize that scientific and technological endeavours have been and continue to be influenced by human needs and the societal context of the time (GLO B2)

**SPECIFIC LEARNING OUTCOME**

**S4P-2-20: Solve problems for charges moving between or through parallel plates.**



**SUGGESTIONS FOR INSTRUCTION**

**Entry Level Knowledge**

Students know that  $\Delta V = q\varepsilon\Delta d$  for a charge between parallel plates. Also, the force on a charge in an electric field is  $\vec{F} = q\vec{\varepsilon}$ . The Millikan experiment was also described in Senior 3 Physics.

**Notes to the Teacher**

Parallel plates have a uniform electric field between them and a charged particle in that field will experience a constant force, resulting in a constant acceleration. These conditions allow us to apply the kinematics equations from Topic 1 to analyze the motion.

A charged particle projected horizontally into the field between parallel plates will behave like a projectile in a gravitational field. Consequently, the particle is deflected up or down. Instead of  $g$ , we use the electric field constant for the plates to make our calculations.



**SKILLS AND ATTITUDES OUTCOMES**

**S4P-0-2e:** Evaluate the relevance, reliability, and adequacy of data and data-collection methods.  
Include: discrepancies in data and sources of error

**S4P-0-2g:** Develop mathematical models involving linear, power, and/or inverse relationships among variables.

**GENERAL LEARNING OUTCOME CONNECTION**

*Students will...*

Understand the composition of the universe, the interactions within it, and the impacts of humankind's continued attempts to understand and explore it (GLO D6)

**SUGGESTIONS FOR INSTRUCTION**

**SUGGESTIONS FOR ASSESSMENT**

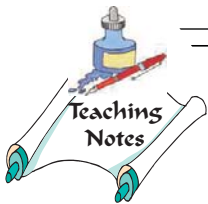

A large, empty rectangular box intended for handwritten or typed notes under the 'SUGGESTIONS FOR INSTRUCTION' header.

**Pencil-and-Paper Tasks**

Students solve problems for the motion of a charged particle in a constant field.



**GENERAL LEARNING OUTCOME CONNECTION**

*Students will...*

Describe scientific and technological developments, past and present, and appreciate their impact on individuals, societies, and the environment, both locally and globally (GLO B1)

**SPECIFIC LEARNING OUTCOMES**

**S4P-2-21: Use hand rules to describe the directional relationships between electric and magnetic fields and moving charges.**

**S4P-2-22: Describe qualitatively various technologies that use electric and magnetic fields.**

*Examples: electromagnetic devices (such as solenoid, motor, bell, or relay), cathode ray tube, mass spectrometer, antenna*

**SKILLS AND ATTITUDES OUTCOMES**

**S4P-0-2a:** Select and use appropriate visual, numeric, graphical, and symbolic modes of representation to identify and represent relationships.



**SUGGESTIONS FOR INSTRUCTION**

**Entry Level Knowledge**

At this time, students have studied electrostatics, electric fields, and magnetic fields. Specifically, understanding the magnetic field around a current carrying wire and the magnetic field of a solenoid were outcomes in Senior 3 Physics.

**Notes to the Teacher**

The right-hand rules are also related to learning outcomes in Topic 3. The right-hand rules are summarized here, but you may introduce the rules as they are needed.

**Class Discussion**

Static electric charges exert forces of repulsion and attraction on each other. In the early 1800s, Hans Christian Ørsted observed the deflection of a compass needle when an electric current flowed in a nearby wire to establish a connection between electricity and magnetism. Magnetic fields act on moving charges. However, there is a significant difference: the magnetic force ( $F_B$ ) is perpendicular to the direction of the motion of the charge. Consequently, no work is done on the charge and there is no change in the magnitude of velocity—only a change in direction occurs. If the force and velocity are constant and at right angles to each other, the particle will go in a circle of radius  $R$ , and the magnetic force  $F_B$  will act as a centripetal force  $F_C$ . To determine the direction of

the force, field, or motion, physicists use a set of right-hand rules (in some texts these are described as left-hand rules). The right-hand rules use a conventional current flow (positive to negative) and the left-hand rules use the electron flow (negative to positive).

**Right-Hand Rules**

**To determine the direction of the magnetic field around a current-carrying wire:**

Point the thumb of the right hand in the direction of the current (positive to negative) and the fingers will curl in the direction of the magnetic field around the wire.

**To determine the direction of the magnetic field of a solenoid:**

Curl the fingers in the direction of the current (positive to negative) and the thumb points in the direction of the magnetic field (inside a solenoid the field points S to N).

**To determine the direction of magnetic force on a moving charge:**

The thumb points in the direction of the positive velocity of the charge, the fingers point in the direction of the field, and the force points in the direction the palm would push. **Note:** The positive velocity of a positive charge moving to the right is right, the positive velocity of a negative charge moving right is left.



**SKILLS AND ATTITUDES OUTCOMES**

**S4P-0-2f:** Record, organize, and display data using an appropriate format.

Include: labelled diagrams, tables, graphs

**S4P-0-3b:** Describe examples of how technology has evolved in response to scientific advances, and how scientific knowledge has evolved as the result of new innovations in technology.

**S4P-0-3c:** Identify social issues related to science and technology, taking into account human and environmental needs and ethical considerations.

**S4P-0-4e:** Demonstrate a continuing and more informed interest in science and science-related issues.

**GENERAL LEARNING OUTCOMES CONNECTION**

*Students will...*

Recognize that scientific and technological endeavours have been and continue to be influenced by human needs and the societal context of the time (GLO B2)

Demonstrate appropriate scientific inquiry skills when seeking answers to questions (GLO C2)

**SUGGESTIONS FOR INSTRUCTION**

**SUGGESTIONS FOR ASSESSMENT**

**Student Research/Report**

Students research and report or display the applications of electric and magnetic fields. In their report, students should provide an explanatory model of how the device works.

Several technologies use electric and magnetic fields to manipulate charges. Many of these technologies, such as the cathode ray tube, are very common and should be of interest to students.

**Math Connection**

Students research the historical development of the particle model of electricity and derive the charge to mass ( $e/m$ ) ratio of Thomson's experiment.

**Visual/Multimedia Display**

Students prepare a visual (poster) or multimedia (PowerPoint or web page) display describing a technology that uses electric and/or magnetic fields.



## NOTES



---

## ***TOPIC 3: ELECTRICITY***

3.1: Electric Circuits

3.2: Electromagnetic Induction

---

---

## **TOPIC 3.1: ELECTRIC CIRCUITS**

- S4P-3-1 Describe the origin of conventional current and relate its direction to the electron flow in a conductor.
- S4P-3-2 Describe the historical development of Ohm's Law.  
Include: contributions of Gray, Ohm, Joule, and Kirchoff
- S4P-3-3 Investigate the relationships among resistance and resistivity, length, cross-section, and temperature.  
Include:  $R = \frac{\rho L}{A}$
- S4P-3-4 Demonstrate the ability to construct circuits from schematic diagrams for series, parallel, and combined networks.  
Include: correct placement of ammeters and voltmeters
- S4P-3-5 Calculate the total resistance for resistors in series and resistors in parallel.
- S4P-3-6 Calculate the resistance, current, voltage, and power for series, parallel, and combined networks.  
Include:  $P = IV$ ,  $P = I^2R$ , and  $P = \frac{V^2}{R}$ .
-



**GENERAL LEARNING OUTCOME CONNECTION**

*Students will...*

Evaluate, from a scientific perspective, information and ideas encountered during investigations and in daily life (GLO C8)

**SPECIFIC LEARNING OUTCOME**

**S4P-3-1: Describe the origin of conventional current and relate its direction to the electron flow in a conductor.**



---

**SUGGESTIONS FOR INSTRUCTION**

**Entry Level Knowledge**

In Senior 1 Science, students studied electrostatics and the particle model of electricity. According to this model, only negative charges move in a conductor.

**Notes to the Teacher**

Benjamin Franklin advocated a one-fluid model of electricity where the electrical “fluid” would move from a region where there was more of it to a region where there was less fluid. He called the more plentiful region *positive* and the less plentiful area *negative*. According to this theory, electricity moves from positive to negative and is called the **conventional current of electricity**. Years later, the actual flow of electricity was determined to be negative electrons moving from a negative region to a positive region (opposite to Franklin’s theory). This movement was called the **electron flow**.

Certain laws of physics depend on the direction of flow of electricity. Many physics texts continue to use a conventional flow of electricity and a corresponding set of “right-hand rules.” Electricians tend to use the electron flow of electricity and a corresponding set of “left-hand rules.” Each system adequately explains the relation between electricity and magnetism. The teacher may decide to use either right-hand or left-hand rules. This learning outcome merely differentiates between conventional and electron flow of electricity.



**SKILLS AND ATTITUDES OUTCOME**

**S4P-0-2c:** Formulate operational definitions of major variables or concepts.

**GENERAL LEARNING OUTCOME CONNECTION**

*Students will...*

Evaluate, from a scientific perspective, information and ideas encountered during investigations and in daily life (GLO C8)

**SUGGESTIONS FOR INSTRUCTION**

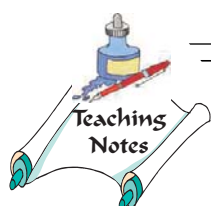

**SUGGESTIONS FOR ASSESSMENT**

Students complete a compare and contrast frame for conventional and electron current (SYSTH).

**SUGGESTED LEARNING RESOURCES**

See Appendix 3.1: The Historical Development of Ohm's Law.



GENERAL LEARNING OUTCOME CONNECTION	SPECIFIC LEARNING OUTCOME	SKILLS AND ATTITUDES OUTCOMES 
<p><i>Students will...</i></p> <p>Identify and appreciate contributions made by women and men from many societies and cultural backgrounds toward increasing our understanding of the world and in bringing about technological innovations (GLO A4)</p>	<p><b>S4P-3-2: Describe the historical development of Ohm’s Law.</b></p> <p>Include: contributions of Gray, Ohm, Joule, and Kirchoff</p>	<p><b>S4P-0-1a:</b> Explain the roles of theory, evidence, and models in the development of scientific knowledge.</p> <p><b>S4P-0-1b:</b> Describe the importance of peer review in the evaluation and acceptance of scientific theories, evidence, and knowledge claims.</p>

### SUGGESTIONS FOR INSTRUCTION

#### Entry Level Knowledge

In Senior 1 Science, students extended the particle model of electricity to electric circuits. In their investigations Ohm’s Law is implied by the inverse relation between current and resistance. That is, students note that as resistance increases, current decreases. Students are also introduced to the concept of voltage; however, this is a very difficult concept and should be revisited.

#### Notes to the Teacher

The typical treatment of Ohm’s Law involves an experiment to graph voltage and current for a resistance. The slope of the line is given as the resistance and Ohm’s Law is established. This method is really just a circular proof of the law, since the voltmeter is calibrated using Ohm’s Law in the first place. A more accurate (and pedagogically rich) representation is the historical approach that begins with Gray’s demonstration of the conduction of electricity; Ohm’s demonstration that current is inversely proportional to resistance; Joule’s connection of power to current and resistance; and Kirchoff’s synthesis of electrostatics, Ohm’s, and Joule’s work. Since textbooks will not use an historical approach, a complete outline is provided for the teacher in Appendix 3.1. Additionally, the historical approach permits a consideration of the Nature of Science skills outcomes.

#### Prior Knowledge Activities

Students learn best when they are able to relate new knowledge to what they already know. Use a KWL chart (SYSTH) to activate and assess students’ prior knowledge of electric circuits.

#### Student Research/Web Quest

Students research the contributions of other scientists to the development of our understanding of voltage, current, and resistance. Some scientists to consider are Volta, Davy, Faraday, and Ampere.

#### Laboratory Activities

Several experiments are described in the appendix. Ohm’s experiment and Joule’s experiment are integral to the historical approach.

The more traditional experiment of measuring voltage and current can be found in most textbooks. Although not a proof of Ohm’s Law, the activity is useful as students learn to build circuits and use electric meters. It serves as a good follow-up to the historical approach.



**SKILLS AND ATTITUDES OUTCOMES**

**S4P-0-1c:** Relate the historical development of scientific ideas and technology to the form and function of scientific knowledge today.

**S4P-0-1d:** Describe how scientific knowledge changes as new evidence emerges and/or new ideas and interpretations are advanced.

**S4P-0-1e:** Differentiate between how scientific theories explain natural phenomena and how scientific laws identify regularities and patterns in nature.

**S4P-0-2e:** Evaluate the relevance, reliability, and adequacy of data and data-collection methods.

Include: discrepancies in data and sources of error

**S4P-0-2g:** Develop mathematical models involving linear, power, and/or inverse relationships among variables.

**GENERAL LEARNING OUTCOME CONNECTION**

*Students will...*

Describe scientific and technological developments, past and present, and appreciate their impact on individuals, societies, and the environment, both locally and globally (GLO B1)

**SUGGESTIONS FOR INSTRUCTION**

**SUGGESTIONS FOR ASSESSMENT**

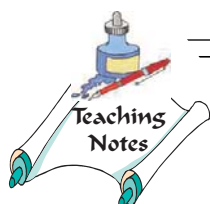

Empty box for teaching notes.

**Laboratory Report**

Students complete a formal laboratory report for Ohm’s Law and Joule’s Law.

**Demonstration of an Understanding of the Major Explanatory Stories in Science**

Students explain their understanding of the particle model of electricity and the relationships among voltage, current, and resistance.

**Observation**

Observe to determine if students have correctly connected electrical circuits.

**SUGGESTED LEARNING RESOURCES**

See Appendix 3.1: The Historical Development of Ohm’s Law.



**GENERAL LEARNING OUTCOME CONNECTION**

*Students will...*

Understand the composition of the universe, the interactions within it, and the impacts of humankind's continued attempts to understand and explore it (GLO D6)

**SPECIFIC LEARNING OUTCOME**

**S4P-3-3: Investigate the relationships among resistance and resistivity, length, cross-section, and temperature.**

Include:  $R = \frac{\rho L}{A}$



**SUGGESTIONS FOR INSTRUCTION**

**Notes to the Teacher**

The resistance of a material depends on several factors including:

- **Resistivity:** Resistivity, represented by the Greek letter *rho* ( $\rho$ ), depends upon properties of the material as well as on temperature. It is an indication of how the material resists the movement of charge through it. Resistivity has units of  $\Omega \cdot m$ . Be careful when consulting tables since the units are not always represented in metres.
- **Length:** A longer conductor offers more resistance than a shorter conductor, since charge must move through more matter. Length is measured in metres.
- **Cross-Sectional Area:** A material with a larger cross-sectional area offers less resistance to charge movement than one with a smaller area. There is more room for charge to move in the wider area. Area must be measured in metres squared to be consistent with resistivity and length.

These factors are combined to determine the resistance of any material, given by the relationship

$$R = \frac{\rho L}{A}$$

Temperature also affects the resistance of materials. Most materials offer more resistance to moving charges at higher temperatures. Most values of resistivity are given at the standard temperature of 20° C.

**Laboratory Activity**

Students perform a laboratory activity to find the relationship between resistance and length of conductor. At this time, the resistance can easily be found by Ohm's Law

$$\left( R = \frac{V}{I} \right)$$

Students can also perform a lab to find the relationship between resistance and cross-sectional area. Use wires of the same length and different gauges for the measurements.



**SKILLS AND ATTITUDES OUTCOMES**

**S4P-0-2g:** Develop mathematical models involving linear, power, and/or inverse relationships among variables.

**S4P-0-2e:** Evaluate the relevance, reliability, and adequacy of data and data-collection methods.

Include: discrepancies in data and sources of error

**GENERAL LEARNING OUTCOME CONNECTION**

*Students will...*

Understand the composition of the universe, the interactions within it, and the impacts of humankind's continued attempts to understand and explore it (GLO D6)

**SUGGESTIONS FOR INSTRUCTION**

**SUGGESTIONS FOR ASSESSMENT**

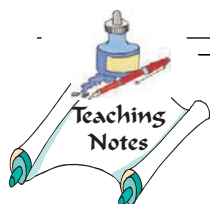

A large empty rectangular box for writing suggestions for instruction.

**Performance Assessment**

Give students three different types of wires (e.g., copper, German silver, nichrome). After appropriate measurements, students calculate resistivity and are required to order them according to their resistivity.

**Laboratory Report**

Students complete a laboratory report on resistivity.

**Pencil-and-Paper Tasks**

Students solve problems using the resistivity formula.



**GENERAL LEARNING OUTCOME CONNECTION**

*Students will...*

Recognize safety symbols and practices related to scientific and technological activities and to their daily lives, and apply this knowledge in appropriate situations (GLO C1)

**SPECIFIC LEARNING OUTCOME**

**S4P-3-4: Demonstrate the ability to construct circuits from schematic diagrams for series, parallel, and combined networks.**

Include: correct placement of ammeters and voltmeters



---

**SUGGESTIONS FOR INSTRUCTION**

**Entry Level Knowledge**

In Senior 1 Science, students constructed simple series and parallel circuits with dry cells, switches, bulbs, and meters.

**Notes to the Teacher**

Series circuits have only one path so all devices are connected end-to-end. The same current passes through each component in the circuit. Ammeters, used to measure current, must always be connected in series. Analogue meters (containing moving needles) must be used very carefully. The meter has an overall low resistance so as not to affect the circuit in which it is placed. An ammeter connected in parallel may draw a large current and be ruined. Also, the meter must be placed with its negative (black) terminal connected to the low-voltage side of the circuit and the positive (red) terminal to the high-voltage side. Finally, a meter should always be set to its highest possible reading when first connected in the circuit. If the needle does not deflect enough to make an accurate measurement, select a lower value in the current range. (Digital multimeters are not as sensitive to incorrect hook-up as are analogue meters.)

Parallel circuits consist of multiple paths called **branches**. They can be recognized by junctions where the current splits or joins. Individual branches may have different values of current but they all have the same potential drop across them. Voltmeters measure voltages or potential differences. Voltmeters contain a high resistance in series with the coil of the meter and they are connected in parallel to the part of the circuit being measured. Therefore, voltmeters draw very little current compared to the original circuit. Proper polarities must also be observed, as well as starting at a high range and working down to a more appropriate level.

Students often have difficulty constructing circuits from schematic diagrams. Take time to allow them to practise circuit construction and the correct placement of meters. It is advisable to have the master power switch off until you have checked all the students' circuits.

**Demonstration**

Suspend a strip of aluminum foil between the poles of a magnet. Connect the ends of the aluminum strip to a power supply. The current in the foil will establish a magnetic field, which interacts with the magnetic field of the magnet. The foil deflects. An electric meter works on the same principle.



**SKILLS AND ATTITUDES OUTCOMES**

- S4P-0-2d:** Estimate and measure accurately using SI units.
- S4P-0-4a:** Demonstrate work habits that ensure personal safety, the safety of others, and consideration of the environment.

**GENERAL LEARNING OUTCOME CONNECTION**

*Students will...*  
 Demonstrate appropriate critical thinking and decision-making skills when choosing a course of action based on scientific and technological information (GLO C4)

**SUGGESTIONS FOR INSTRUCTION**

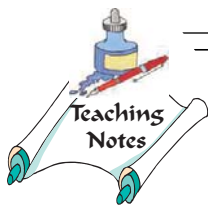

**SUGGESTIONS FOR ASSESSMENT**

**Observation**

Check for correct placement of meters before the student turns on the power supply.

**Science Journal Entries**

Students predict the behaviour of a circuit if the meters are placed incorrectly.

**Pencil-and-Paper Tasks**

Students diagram the correct placement of meters in an electric circuit.





**GENERAL LEARNING OUTCOME CONNECTION**

*Students will...*

Demonstrate appropriate scientific inquiry skills when seeking answers to questions (GLO C2)

**SPECIFIC LEARNING OUTCOME**

**S4P-3-5: Calculate the total resistance for resistors in series and resistors in parallel.**



**SUGGESTIONS FOR INSTRUCTION**

**Entry Level Knowledge**

In Senior 1 Science, students visually noted the decrease in brightness of bulbs that were connected in a series arrangement.

**Notes to the Teacher**

The explanation of series and parallel combinations of resistors can be done conceptually or mathematically.

**SERIES RESISTORS**

**Qualitative Discussion**

Resistors placed in series act like longer resistors so the total resistance must be the sum of the individual resistors:  $R_T = R_1 + R_2 + R_3 \dots$

The total resistance for a series network is always larger than any of the single resistances.

**Mathematical Treatment**

In the series circuit above, the resistors are in series so they must have the same current passing through them:  $I_1 = I_2 = I_3 = I$ . Each resistor gives off energy as heat and has a voltage drop across it. The combined resistance will also draw the same current as all the series resistors.

The sum of the individual voltage drops must equal the source voltage. (This is known as Kirchoff's Voltage Law and is really a consequence of the Law of Conservation of Energy.)

$$V_T = V_1 + V_2 + V_3.$$

Since  $V_{\text{drop}} = IR$ , then

$$IR_T = IR_1 + IR_2 + IR_3.$$

$$\text{So, } R_T = R_1 + R_2 + R_3.$$

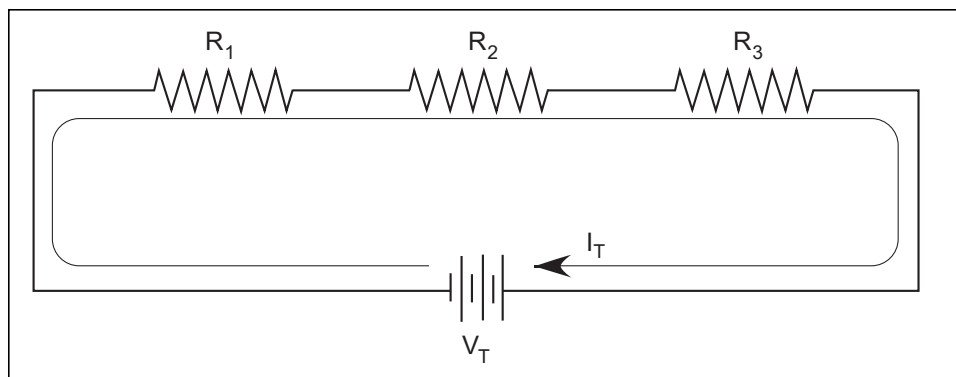

Series Resistors



**SKILLS AND ATTITUDES OUTCOMES**

**S4P-0-2c:** Formulate operational definitions of major variables or concepts.

**S4P-0-2g:** Develop mathematical models involving linear, power, and/or inverse relationships among variables.

**GENERAL LEARNING OUTCOME CONNECTION**

*Students will...*

Evaluate, from a scientific perspective, information and ideas encountered during investigations and in daily life (GLO C8)

**SUGGESTIONS FOR INSTRUCTION****SUGGESTIONS FOR ASSESSMENT****Example**

Find the combined resistance of a series network consisting of  $10\ \Omega$ ,  $12\ \Omega$ ,  $18\ \Omega$ , and  $6\ \Omega$ .

$$\begin{aligned} R_T &= R_1 + R_2 + R_3 + R_4 \\ &= 10\ \Omega + 12\ \Omega + 18\ \Omega + 6\ \Omega \\ &= 46\ \Omega \end{aligned}$$

**PARALLEL RESISTORS****Qualitative Discussion**

Adding a resistance in parallel is the same as increasing the cross-sectional area through which current can flow. We have already established that resistance is inversely proportional to the cross-sectional area. This suggests an inverse relationship between total resistance and the number of resistors in parallel.

$$\frac{1}{R_T} = \frac{1}{R_1} + \frac{1}{R_2} + \frac{1}{R_3} \dots$$

It is important to note that the equivalent resistance for a parallel network is always less than the smallest branch resistance. This is a useful check when analyzing a circuit.

**Pencil-and-Paper Tasks**

Students solve problems for various combinations of electric circuits.



**GENERAL LEARNING OUTCOME CONNECTION**

*Students will...*

Demonstrate appropriate scientific inquiry skills when seeking answers to questions (GLO C2)

**SPECIFIC LEARNING OUTCOME**

**S4P-3-5: Calculate the total resistance for resistors in series and resistors in parallel.**



**SUGGESTIONS FOR INSTRUCTION**

**Mathematical Discussion**

The voltages across resistances in parallel are equal and are the same as the source voltage:  $V_1 = V_2 = V_3 = V_T$ . The total current that leaves the source is determined by the source voltage and the total resistance of the network. This total current breaks up into separate branch currents but then recombines to produce the total current that returns to the source. (This is Kirchoff's Current Law and relates to conservation of electric charge.) Charge does not disappear, nor is it created when it enters the junction. It is merely rearranged with differing amounts of charge passing through different branches. The amount of current in each branch depends upon the resistance of the branch.

$$I_T = I_1 + I_2 + I_3$$

Since current is found from Ohm's Law,  $I = \frac{V}{R}$ :

$$\text{so } \frac{V_T}{R_T} = \frac{V_T}{R_1} + \frac{V_T}{R_2} + \frac{V_T}{R_3}$$

**Example**

Find the equivalent resistance for 12 and 6 hooked in parallel.

$$\frac{1}{R_T} = \frac{1}{R_1} + \frac{1}{R_2}$$

$$\frac{1}{R_T} = \frac{1}{12} + \frac{1}{6} = \frac{1}{12} + \frac{2}{12} = \frac{3}{12} = \frac{1}{4}$$

$$\therefore R_T = \frac{4}{1} = 4 \Omega$$

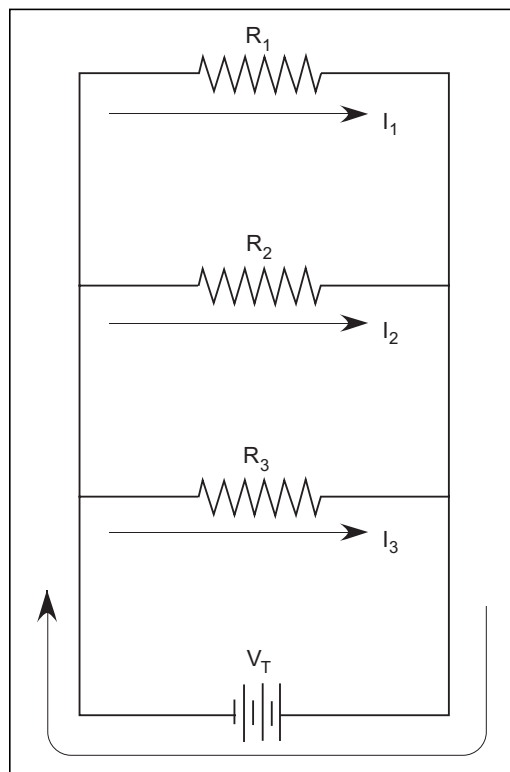

Parallel Resistors



**SKILLS AND ATTITUDES OUTCOMES**

**S4P-0-2c:** Formulate operational definitions of major variables or concepts.

**S4P-0-2g:** Develop mathematical models involving linear, power, and/or inverse relationships among variables.

**GENERAL LEARNING OUTCOME CONNECTION**

*Students will...*

Evaluate, from a scientific perspective, information and ideas encountered during investigations and in daily life (GLO C8)

**SUGGESTIONS FOR INSTRUCTION**

**SUGGESTIONS FOR ASSESSMENT**

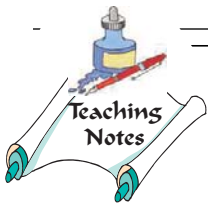

**GENERAL LEARNING OUTCOME CONNECTION**

*Students will...*

Demonstrate appropriate scientific inquiry skills when seeking answers to questions (GLO C2)

**SPECIFIC LEARNING OUTCOME**

**S4P-3-6: Calculate the resistance, current, voltage, and power for series, parallel, and combined networks.**

Include:  $P = IV$ ,  $P = I^2R$ , and  $P = \frac{V^2}{R}$



**SUGGESTIONS FOR INSTRUCTION**

**Entry Level Knowledge**

In Senior 1 Science, students used Watt's Law,  $P = IV$ . Power, measured in watts, is the product of current in amperes and electric potential in volts.

**Notes to the Teacher**

The power law  $P = VI$  can be combined with Ohm's Law to produce two other equations, very useful in circuit analysis.

From  $I = \frac{V}{R}$  and  $P = IV$ ,  $P = I^2R$ , and  $P = \frac{V^2}{R}$ .

**Class Activity**

Circuit analysis would begin with simple series and simple parallel circuits. An illustrative example of the analysis of a combined network or complex circuit is in Appendix 3.3.



**SKILLS AND ATTITUDES OUTCOMES**

**S4P-0-2d:** Estimate and measure accurately using SI units.

**S4P-0-2f:** Record, organize, and display data using an appropriate format.

Include: labelled diagrams, tables, graphs

**GENERAL LEARNING OUTCOME CONNECTION**

*Students will...*

Evaluate, from a scientific perspective, information and ideas encountered during investigations and in daily life (GLO C8)

**SUGGESTIONS FOR INSTRUCTION**

**SUGGESTIONS FOR ASSESSMENT**

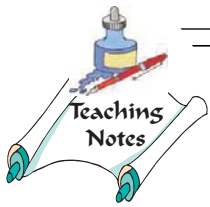

A large, empty rectangular box intended for handwritten or typed notes under the "SUGGESTIONS FOR INSTRUCTION" header.

**Pencil-and-Paper Tasks**

Given a complex network, students reduce the network to its equivalent resistance and calculate the voltage, current, and power in each resistance.



NOTES



---

## **TOPIC 3.2: ELECTROMAGNETIC INDUCTION**

- S4P-3-7 Define magnetic flux ( $\Phi = B_{\perp}A$ ).
- S4P-3-8 Demonstrate how a change in magnetic flux induces voltage.
- S4P-3-9 Calculate the magnitude of the induced voltage in coils using  $V = \frac{N\Delta\Phi}{\Delta t}$ .
- S4P-3-10 Outline Lenz's Law and apply to related problems.
- S4P-3-11 Describe the operation of an AC generator.
- S4P-3-12 Graph voltage versus angle for the AC cycle.
- S4P-3-13 Describe the operation of transformers.
- S4P-3-14 Solve problems using the transformer ratio of  $\frac{V_p}{V_s} = \frac{N_p}{N_s}$ .
- S4P-3-15 Describe the generation, transmission, and distribution of electricity in Manitoba.  
Include: step-up and step-down transformers, power transfer, High Voltage Direct Current
-



**GENERAL LEARNING OUTCOME CONNECTION**

Students will...

Understand the properties and structures of matter as well as various common manifestations and applications of the actions and interactions of matter (GLO D3)

**SPECIFIC LEARNING OUTCOME**

**S4P-3-7: Define magnetic flux ( $\Phi = B_{\perp}A$ ).**



**SUGGESTIONS FOR INSTRUCTION**

**Entry Level Knowledge**

Students diagrammed magnetic fields using lines of force in Senior 3 Physics.

**Notes to the Teacher**

Magnetic flux,  $\Phi$ , represents a quantity of magnetic force lines passing through a given area. The number of magnetic force lines increases if we have a stronger field or if the area enclosed is larger. Therefore,  $\Phi = B_{\perp}A$ . In SI units, flux is measured in webers ( $Wb$ ) and is calculated from  $\Phi = B_{\perp}A$  with  $B$  measured in Tesla and  $A$  in metres squared. It is important to note that only the component of the magnetic field perpendicular to the area is used in the calculation. Thus, in general,  $\Phi = BA\cos\theta$  where  $\theta$  is the angle between the magnetic field and the normal to the area.

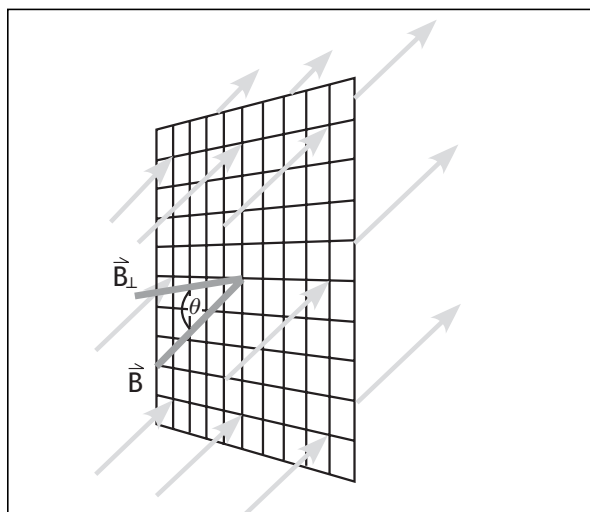

**Example**

A magnetic induction of  $4.5 \times 10^{-5} \text{ T}$  passes through a circular coil of diameter 16.4 cm at an angle of  $41^{\circ}$ .

The perpendicular component of the magnetic field,  $B_{\perp}$ , is equal to:

$$B \cos\theta = (4.5 \times 10^{-5} \text{ T}) \cos 41^{\circ} = 3.40 \times 10^{-5} \text{ T}$$

$$A = \pi r^2 = \pi \left( \frac{0.164 \text{ m}}{2} \right)^2 = 2.11 \times 10^{-2} \text{ m}^2$$

$$\Phi = B_{\perp}A = (3.40 \times 10^{-5} \text{ T})(2.11 \times 10^{-2} \text{ m}^2) = 7.2 \times 10^{-7} \text{ Wb}$$

**Demonstration**

Students perform a two-dimensional simulation of flux lines entering a coil by using a sheet of lined paper and a strip of construction paper 15 cm by 0.5 cm. The strip of construction paper represents the end view of a coil, and the blue lines on the lined paper represent magnetic flux lines. Hold the strip at  $90^{\circ}$  to the lines on the paper and count the number of lines the strip covers. The normal to the coil is parallel to the lines in this position and  $\theta = 0^{\circ}$ .



**SKILLS AND ATTITUDES OUTCOMES**

**S4P-0-1e:** Differentiate between how scientific theories explain natural phenomena and how scientific laws identify regularities and patterns in nature.

**S4P-9-2c:** Formulate operational definitions of major variables or concepts.

**GENERAL LEARNING OUTCOME CONNECTION**

*Students will...*

Understand the properties and structures of matter as well as various common manifestations and applications of the actions and interactions of matter (GLO D3)

**SUGGESTIONS FOR INSTRUCTION**

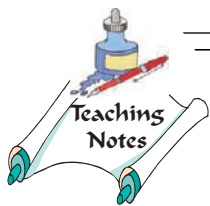

**SUGGESTIONS FOR ASSESSMENT**

**Paper-and-Pencil Tasks**

Students solve problems using the definition of flux.



**GENERAL LEARNING OUTCOME CONNECTION**

*Students will...*

Understand how stability, motion, forces, and energy transfers and transformations play a role in a wide range of natural and constructed contexts (GLO D4)

**SPECIFIC LEARNING OUTCOME**

**S4P-3-8: Demonstrate how a change in magnetic flux induces voltage.**



**SUGGESTIONS FOR INSTRUCTION**

**Entry Level Knowledge**

Students have studied that a charge moving through a magnetic field experiences a deflecting force.

**Notes to the Teacher**

A changing magnetic field exerts a deflecting force on a charge. This results in a charge separation that produces a voltage.

**Demonstration**

Induced voltage can be demonstrated by connecting a solenoid to a galvanometer and moving a bar magnet in and out of the solenoid. The induced voltages result in currents that can be detected by the galvanometer. Note the results of different actions of the magnet. When the magnet is pushed into or pulled out of the solenoid, a current is induced. When the magnet is moved one way (e.g., into the coil), the needle deflects one way; when the magnet is moved the other way (out of the coil), the needle deflects the other way. Not only can a moving magnet cause a current to flow in the coil, the direction of the current depends on how the magnet is moved. However, if the magnet is at rest inside the solenoid, no current is produced in the coil. Consequently, only changing magnetic fields will induce currents.

**Class Discussion**

You can conclude from these observations that a changing magnetic field will induce a voltage in the coil, causing a current to flow. It follows that if the magnetic flux through a coil is changed, a voltage will be produced. This voltage is commonly referred to as the **induced voltage**. The term **voltage**, although common, is an historical term, and students say that a voltage is induced.

There are three possible ways to change magnetic flux (remember that magnetic flux is defined as  $\Phi = BA\cos\theta$ ):

1. change the magnetic field
2. change the area of the loop
3. change the angle between the field and the loop



**SKILLS AND ATTITUDES OUTCOME**

**S4P-0-1d:** Describe how scientific knowledge changes as new evidence emerges and/or new ideas and interpretations are advanced.

**GENERAL LEARNING OUTCOME CONNECTION**

*Students will...*

Understand how stability, motion, forces, and energy transfers and transformations play a role in a wide range of natural and constructed contexts (GLO D4)

**SUGGESTIONS FOR INSTRUCTION**

**SUGGESTIONS FOR ASSESSMENT**

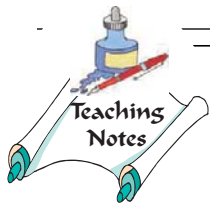

A large, empty rectangular box intended for handwritten or typed notes under the 'SUGGESTIONS FOR INSTRUCTION' header.

**Observation**

Students demonstrate the ability to induce a current in a coil with a moving magnet.



**GENERAL LEARNING OUTCOME CONNECTION**

*Students will...*

Recognize that scientific knowledge is based on evidence, models, and explanations, and evolves as new evidence appears and new conceptualizations develop (GLO A2)

**SPECIFIC LEARNING OUTCOMES**

**S4P-3-9: Calculate the magnitude of the induced voltage in coils using**

$$V = \frac{N\Delta\Phi}{\Delta t}$$

**S4P-3-10: Outline Lenz's Law and apply to related problems.**



**SUGGESTIONS FOR INSTRUCTION**

**Entry Level Knowledge**

Students have been introduced to basic magnetic fields, and the interaction of magnetic fields and a current carrying conductor, in Senior 3 Physics.

**Notes to the Teacher**

Faraday's Law is a fundamental relationship that states that the induced voltage in a coil is proportional to the rate of change of magnetic flux. For a single loop,

$$V = \frac{\Delta\Phi}{\Delta t},$$

it follows that if a coil contains N loops, then

$$V = \frac{N\Delta\Phi}{\Delta t}.$$

If the rate of change of flux is in webers/second, then the voltage will be in volts.

The induced current in a circuit is such that the direction of the magnetic field it produces always opposes the original change in flux. This is a consequence of the Law of Conservation of Energy and basically means that external work must be done in order to produce electrical energy in the circuit. Thus, Faraday's Law requires a minus sign to account for the direction of the induced voltage

$$\left( V = \frac{N\Delta\Phi}{\Delta t} \right).$$

Normally, the minus sign is ignored and the direction of the induced voltage is found by the right-hand rule (or in some texts, the left-hand rule). For a coil, the right-hand rule is:

“If the thumb points in the direction of the magnetic field, the fingers will curl in the direction of the induced current.”

To apply the hand rules, a diagram is required.

**Demonstration**

Allow a moving magnet to induce a current in a coil of wire. Connect the coil to a galvanometer and move a bar magnet in and out of the centre of the coil. Note the deflection of the galvanometer needle. Describe what happens when you move the magnet more or less quickly, and when you put the North or South pole into the coil first. Then, try other relative motions and positions, including some where the axes of the magnet and the coil are perpendicular. Does it make a difference if you move the coil, rather than the magnet, in the same relative motion?



**SKILLS AND ATTITUDES OUTCOMES**

**S4P-0-1e:** Differentiate between how scientific theories explain natural phenomena and how scientific laws identify regularities and patterns in nature.

**S4P-0-2c:** Formulate operational definitions of major variables or concepts.

**GENERAL LEARNING OUTCOME CONNECTION**

*Students will...*

Understand the properties and structures of matter as well as various common manifestations and applications of the actions and interactions of matter (GLO D3)

**SUGGESTIONS FOR INSTRUCTION**

**SUGGESTIONS FOR ASSESSMENT**

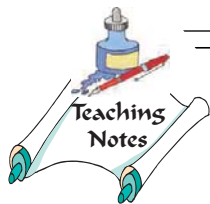

**Laboratory Report**

In their reports, students describe the motions they used, what flux changes they should produce, and how the observed current can be explained by using Faraday's Law and/or Lenz's Law. Some sketches will probably help their explanation.

**Visual Display**

Students prepare diagrams of different scenarios for induced currents and the application of right-hand rules to determine the direction of the current.

**Pencil-and-Paper Tasks**

Students solve problems using the laws of Faraday and Lenz together.



**GENERAL LEARNING OUTCOME CONNECTION**

Students will...

Describe scientific and technological developments, past and present, and appreciate their impact on individuals, societies, and the environment, both locally and globally (GLO B1)

**SPECIFIC LEARNING OUTCOMES**

**S4P-3-11: Describe the operation of an AC generator.**

**S4P-3-12: Graph voltage versus angle for the AC cycle.**



**SUGGESTIONS FOR INSTRUCTION**

**Entry Level Knowledge**

The definition of flux,  $\Phi = BA\cos\theta$ , was covered in a previous learning outcome.

**Notes to the Teacher**

Generally, as a loop rotates in a constant magnetic field, it “cuts” the field lines at different angles and experiences a changing flux. Since the coil is rotating, the circular motion of the coil will result in an induced voltage. In the following diagram, the armature of an AC generator is represented by a rectangular loop ABCD, with side AB connected to slip ring 1 and side CD connected to slip ring 2. The slip rings make contact with brushes. The external circuit is connected to the brushes. The generation of the AC waveform can be explained in terms of the motion of the sides of the loop as it is rotated through the magnetic field.

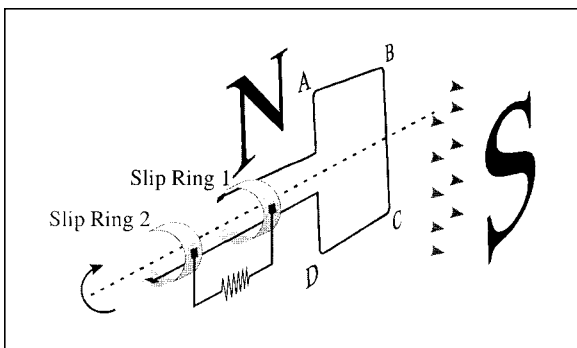

Voltage induced in the loop produces a current that passes from one slip ring, through its brush, through the external circuit, and back to the other brush and to its slip ring. A complete circuit exists.

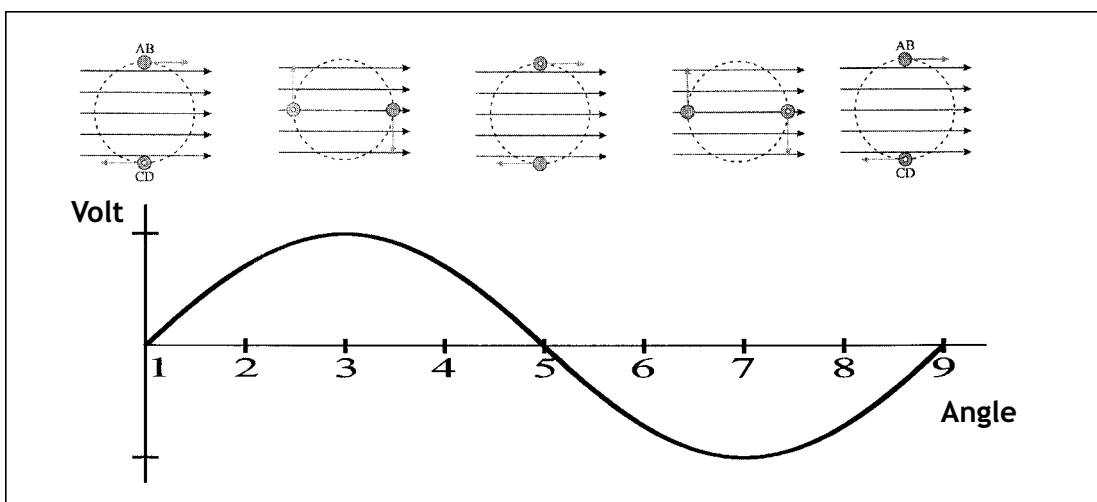

**SKILLS AND ATTITUDES OUTCOME**

**S4P-0-3b:** Describe examples of how technology has evolved in response to scientific advances, and how scientific knowledge has evolved as the result of new innovations in technology.

**GENERAL LEARNING OUTCOMES CONNECTION**

*Students will...*

Describe and appreciate how the natural and constructed worlds are made up of systems and how interactions take place within and among these systems (GLO E2)

Recognize that characteristics of materials and systems can remain constant or change over time, and describe the conditions and processes involved (GLO E3)

**SUGGESTIONS FOR INSTRUCTION**

As the loop rotates, segments AB and CD cut the magnetic field lines and a voltage is induced in the loop. Since the angle at which the segments interact with the field lines changes, so does the induced voltage. In other words, it is not constant and changes direction every half rotation. The previous diagrams are cross-sections of the rotating loop as it corresponds to the changing voltage. Initially, AB and CD are moving parallel to the field lines and the induced voltage is zero (recall that flux is proportional to the sine of the angle that the field lines are “cut”). The induced voltage will be proportional to the sine of the angle and will reach a maximum at  $90^\circ$ . The voltage then decreases to zero and reverses direction in the second half of the rotation.

See Appendix 3.4 for a template to make an overhead of the above graphic.

**SUGGESTIONS FOR ASSESSMENT**

**Pencil-and-Paper Tasks**

Students are given a series of angles for a rotating loop (e.g.,  $0^\circ$ ,  $30^\circ$ ,  $90^\circ$ ,  $225^\circ$ ). The student marks on the sine curve the value of the induced voltage.





**GENERAL LEARNING OUTCOME CONNECTION**

Students will...

Recognize that science and technology interact with and advance one another (GLO A5)

**SPECIFIC LEARNING OUTCOMES**



**S4P-3-13: Describe the operation of transformers.**

**S4P-3-14: Solve problems using the transformer ratio of**

$$\frac{V_p}{V_s} = \frac{N_p}{N_s}$$

**SUGGESTIONS FOR INSTRUCTION**

**Entry Level Knowledge**

In Senior 3 Physics, students diagrammed and described qualitatively the magnetic field around a current-carrying wire. Students also qualitatively described the magnetic field produced in a current-carrying solenoid.

**Notes to the Teacher**

A current in a wire creates a magnetic field around the wire. If this wire is wrapped into a coil, the magnetic field in the centre of the coil will arrange itself such that the field is parallel with the axis of the loop. The direction of the magnetic field in the centre can be found using your right hand. Place your thumb in the direction of conventional current and wrap your fingers around the coil. The direction the fingers point is the direction of the magnetic field. The intensity of the magnetic field in the centre can be varied by either varying the current in the coil or increasing the number of turns in the coil. This principle is used in creating transformers.

The basic transformer consists of two separate (not connected) coils of wire, each wrapped around one side of a rectangular iron core.

As current passes through the primary (input side) coil, it creates a magnetic field inside the iron core. The iron core allows the magnetic field to flow through the secondary coil. This change of magnetic field in the secondary coil induces a voltage across it, which results in a temporary secondary voltage and current in the output coil. If the current in the primary coil is now reversed, the magnetic field it creates will also reverse. The magnetic field through the secondary coil is now reversed, which again induces a temporary secondary voltage and resulting output current. In order to achieve a continuous output voltage in the secondary coil, a continuously changing current in the primary coil is required. Thus, transformers require alternating current to be operational. The output current will be alternating as well.

In order to obtain a voltage in the secondary coil that is different from the voltage in the primary coil, the number of turns for each coil can be varied. A small number of turns in the primary coil will result in a weak magnetic field being produced. However, if this weak magnetic field links a secondary coil with a large number of turns, the voltage induced will be large. Thus, the output

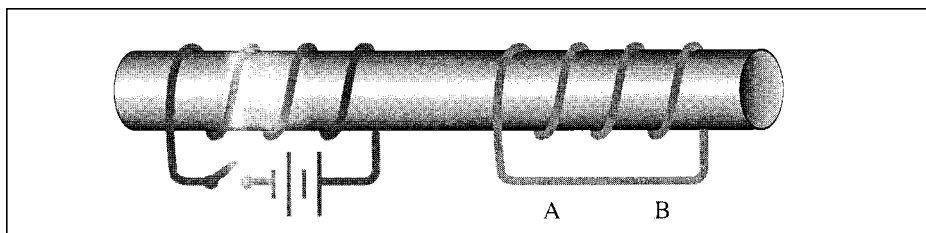

**SKILLS AND ATTITUDES OUTCOMES**

**S4P-0-2i:** Select and integrate information obtained from a variety of sources.

Include: print, electronic, specialists, or other resource people

**S4P-0-3b:** Describe examples of how technology has evolved in response to scientific advances, and how scientific knowledge has evolved as the result of new innovations in technology.

**S4P-0-4e:** Demonstrate a continuing and more informed interest in science and science-related issues.

**GENERAL LEARNING OUTCOME CONNECTION**

*Students will...*

Understand the properties and structures of matter as well as various common manifestations and applications of the actions and interactions of matter (GLO D3)

**SUGGESTIONS FOR INSTRUCTION**

voltage will be larger than the input voltage. A transformer of this nature is called a **step-up transformer**. The same principle is also used when the primary coil has a large number of turns and the secondary coil has a small number of turns. This is called a **step-down transformer** and results in the output voltage being smaller than the input voltage. Transformers are classified in terms of the relative sizes of output (secondary) and input (primary) voltages.

In summary, transformers utilize alternating current to raise or lower voltages of a source by linking magnetic field through two non-connected wires.

It can be reasoned that the voltage induced in the secondary coil is proportional to the number of turns in the coil. As well, the flux created in the primary coil is directly proportional to the number of turns in the primary coil and directly proportional to the voltage of the coil. As a result,

$$\frac{V_p}{V_s} = \frac{N_p}{N_s}$$

**SUGGESTIONS FOR ASSESSMENT**

**Student Research/Report**

Students research the use of transformers by Manitoba Hydro. The research should include the concept of how the transformers work, the actual physical layout of transformers built by Manitoba Hydro, and the varying points at which transformers are positioned by Manitoba Hydro.

Students can locate “broken” 12 V (or any voltage) adapters that can be taken apart and examined. They can submit a report that explains the details of each component in the adapter. Before disassembling any electrical equipment, it is necessary to remove wires so that the apparatus can never be plugged in.

**Student Demonstration**

Students can build transformers using a large nail and wire. Have them try to create a transformer of a specified output, given the value of the input source.

**Pencil-and-Paper Tasks**

Students solve questions using the transformer relation.



**GENERAL LEARNING OUTCOME CONNECTION**

Students will...

Recognize that science and technology interact with and advance one another (GLO A5)

**SPECIFIC LEARNING OUTCOMES**



**S4P-3-13: Describe the operation of transformers.**

**S4P-3-14: Solve problems using the transformer ratio of**

$$\frac{V_p}{V_s} = \frac{N_p}{N_s}$$

**SUGGESTIONS FOR INSTRUCTION**

Students may be tempted to think that since the voltage output of a transformer can be higher than the voltage input, the transformer can increase the amount of power output. This would be like obtaining energy from nothing. However, since energy is always conserved, the power output cannot exceed the power input. In fact, since a transformer will warm up, it is evident that the power output will be less than the power input. Assuming the ideal:

Power into primary = Power out of secondary

$$P_p = P_s$$

$$V_p I_p = V_s I_s$$

$$\frac{V_p}{V_s} = \frac{I_s}{I_p}$$

Note from the above relation that a coil with a high voltage will have a low current (and a high effective resistance), and a coil with a low voltage will have a high current (and a low effective resistance).

**Illustrative Example**

What is the ratio of turns for a transformer that requires a 4-volt output from a 120-volt input source?

**Solution:**

Utilizing  $\frac{V_p}{V_s} = \frac{N_p}{N_s}$ ,  $\frac{120V}{4V} = 30$ .

Thus, the ratio of turns for  $N_p$  to  $N_s$  is 30. An example of a transformer like this might have 300 turns in the primary coil and 10 turns in the secondary coil.



**SKILLS AND ATTITUDES OUTCOMES**

**S4P-0-2i:** Select and integrate information obtained from a variety of sources.

Include: print, electronic, specialists, or other resource people

**S4P-0-3b:** Describe examples of how technology has evolved in response to scientific advances, and how scientific knowledge has evolved as the result of new innovations in technology.

**S4P-0-4e:** Demonstrate a continuing and more informed interest in science and science-related issues.

**GENERAL LEARNING OUTCOME CONNECTION**

*Students will...*

Understand the properties and structures of matter as well as various common manifestations and applications of the actions and interactions of matter (GLO D3)

**SUGGESTIONS FOR INSTRUCTION**

**SUGGESTIONS FOR ASSESSMENT**

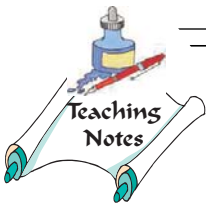

A large, empty rectangular box intended for handwritten notes under the 'SUGGESTIONS FOR INSTRUCTION' header.

A large, empty rectangular box intended for handwritten notes under the 'SUGGESTIONS FOR ASSESSMENT' header.



GENERAL LEARNING OUTCOME CONNECTION	SPECIFIC LEARNING OUTCOME	SKILLS AND ATTITUDES OUTCOMES
<p><i>Students will...</i></p> <p>Distinguish critically between science and technology in terms of their respective contexts, goals, methods, products, and values (GLO A3)</p>	<p><b>S4P-3-15: Describe the generation, transmission, and distribution of electricity in Manitoba.</b></p> <p>Include: step-up and step-down transformers, power transfer, High Voltage Direct Current</p>	<p><b>S3P-0-1c:</b> Relate the historical development of scientific ideas and technology to the form and function of scientific knowledge today.</p> 

### SUGGESTIONS FOR INSTRUCTION

#### Entry Level Knowledge

Students were introduced to the generation and transmission of hydroelectric power in Senior 1 Science.

#### Notes to the Teacher

Manitoba holds tremendous resource potential to supply electricity from a renewable energy source: hydroelectric power. Several generating stations are located throughout the province, with more being considered in northern regions. To transmit the power efficiently, the output from a generating station is stepped up to high-voltage levels (500 kV). This reduces the current, which results in less heat developed in the wires. The heat is wasted energy so it is far more economical to transmit at higher voltage and lower current.

As well, the high-voltage/low-current lines can be produced lighter, since the magnitude of current for the same power distribution is smaller. However, due to arcing, the wires must be very high off the ground and the insulators used are very large. To distribute electricity to major regions, the voltage is stepped down to 115 kV. This allows the towers and insulators to be smaller. Each region then distributes the power to communities at an even lower voltage (66 kV or 33 kV), and again the towers and insulators can be made smaller. The community then distributes the power to neighbourhood substations, where it is reduced again by five to ten times.

At this stage, the power is distributed by the familiar hydro poles and is finally reduced at pole-top transformers to 220 V, which is then distributed to three or four of the neighbouring houses. The lower voltage is much safer within a community and requires smaller poles.

Although alternating current is preferred due to the ease in transforming it to various voltages and currents, Manitoba Hydro is also a pioneer in the development of High Voltage Direct Current (HVDC). It is more economical to transmit power from long distances (over 300 km) as direct current rather than alternating current. DC requires only two conductors per circuit, whereas the AC lines use three conductors (3-phase AC). The AC towers must be structurally stronger to support the extra cable. The costs associated with the materials, and their construction, are much lower for long-distance DC lines than for AC lines. To transmit the power as DC, the AC from the generating station is rectified to DC in a converter station. Once transmitted to southern areas, the DC is changed back to AC in an inverter station. All remaining lines carry alternating current and simply use step-down transformers.



**SKILLS AND ATTITUDES OUTCOMES**

**S4P-0-3a:** Analyze, from a variety of perspectives, the risks and benefits to society and the environment when applying scientific knowledge or introducing technology.

**S4P-0-3c:** Identify social issues related to science and technology, taking into account human and environmental needs and ethical considerations.

**S4P-0-4d:** Develop a sense of personal and shared responsibility for the impact of humans on the environment, and demonstrate concern for social and environmental consequences of proposed actions.

**GENERAL LEARNING OUTCOME CONNECTION**

*Students will...*

Identify and demonstrate actions that promote a sustainable environment, society, and economy, both locally and globally (GLO B5)

**SUGGESTIONS FOR INSTRUCTION**

**SUGGESTIONS FOR ASSESSMENT**

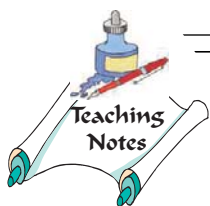

A large empty rectangular box intended for handwritten or typed notes under the 'SUGGESTIONS FOR INSTRUCTION' header.

**Research/Report**

Students research the development of the Manitoba Hydro network.

**Debate**

Students research and debate the works of Thomas Edison and Nicola Tesla in the battle of alternating current versus direct current.

**SUGGESTED LEARNING RESOURCES**

Energy and economic development website of the government of Manitoba:

<<http://www.gov.mb.ca/est/energy/power/statistics.html>>



NOTES



---

# ***TOPIC 4: MEDICAL PHYSICS***

4.1: Medical Physics

---



---

## **TOPIC 4.1: MEDICAL PHYSICS**

- S4P-4-1 Describe the nuclear model of the atom.  
Include: proton, neutron, nucleus, nuclear forces, stability, isotope, mass number, electron, ion
- S4P-4-2 Define radioactivity as a nuclear change that releases energy.  
Include: Becquerel units, radioactive decay, half life
- S4P-4-3 Perform decay calculations using integer numbers of half life.
- S4P-4-4 Describe the following types of radiation: alpha, beta, and electromagnetic radiation.  
Include: particle radiation, wave radiation, electromagnetic spectrum, linear energy transfer
- S4P-4-5 Compare and contrast sources and characteristics of ionizing radiation and non-ionizing radiation.  
Include: NORM (Naturally Occurring Radioactive Materials), radon, background radiation, incandescent light bulb, hot objects
- S4P-4-6 Describe various applications of non-ionizing radiation.  
*Examples: communications, microwave oven, laser, tanning bed*
- S4P-4-7 Describe various applications of ionizing radiation.  
*Examples: food irradiation, sterilization, smoke alarm*
- S4P-4-8 Describe the effects of non-ionizing and ionizing radiation on the human body.  
Include: equivalency of sievert (Sv) and rem units, solar erythema (sunburn)
- S4P-4-9 Research, identify, and examine the application of radiation to diagnostic imaging and treatment techniques.  
*Examples: nuclear medicine imagery techniques such as MRI, ultrasound, endoscopy, X-ray, CT scanning, PET, heavy isotopes such as Ba; nuclear medicine therapies such as brachithery, external beam, gamma knife*
-

**GENERAL LEARNING OUTCOME CONNECTION**

*Students will...*

Recognize that scientific knowledge is based on evidence, models, and explanations, and evolves as new evidence appears and new conceptualizations develop (GLO A2)

**SPECIFIC LEARNING OUTCOME**



**S4P-4-1: Describe the nuclear model of the atom.**

Include: proton, neutron, nucleus, nuclear forces, stability, isotope, mass number, electron, ion

---

**SUGGESTIONS FOR INSTRUCTION**

**Entry Level Knowledge**

The Bohr model of the atom was introduced in Senior 1 Science. In addition, the four fundamental forces were introduced in Senior 3 Physics.

**Notes to the Teacher**

**Atoms** can be described as the building blocks of matter. Atoms contain a central region known as the **nucleus**, which contains most of the atom's mass, and all its positive charge. **Electrons** surround the nucleus, and carry a negative charge; each electron has a negative charge that exactly balances the positive charge of a proton in the nucleus. **Neutral atoms** contain a balance of protons and electrons, and so have no net charge. The term **ion** is used for an atom that is not neutral. Ions may be positive or negative, depending on which is greater, the number of protons or electrons.

The basic building blocks of the nucleus are two different types of particles: **protons** and **neutrons**, which are collectively referred to as **nucleons**. Protons and neutrons have masses that are nearly equal, but have different charge states: protons are positively charged and neutrons are uncharged. It is the number of protons in the nucleus that provide the nucleus with its elemental identity. This is referred to as the **atomic number**. As an example, any atom with 6 protons in the nucleus is identified as carbon.

The number of nucleons in an atom determines its **mass number**. It is important to note that elements generally have more than one possible mass number, as the number of neutrons can vary, even for atoms of the same element. Such variations of an element are referred to as **isotopes**. As an example, most carbon atoms have 6 neutrons. These atoms therefore have 12 nucleons, and make up one isotope of carbon: Carbon-12. A small number of naturally occurring carbon atoms have 5 neutrons, and so 11 nucleons. This is another isotope of carbon: Carbon-11.



**SKILLS AND ATTITUDES OUTCOME**

**S4P-0-1c:** Relate the historical development of scientific ideas and technology to the form and function of scientific knowledge today.

**GENERAL LEARNING OUTCOME CONNECTION**

*Students will...*

Understand the properties and structures of matter as well as various common manifestations and applications of the actions and interactions of matter (GLO D3)

**SUGGESTIONS FOR INSTRUCTION**

**SUGGESTIONS FOR ASSESSMENT**

The particles within a nucleus continually exert forces on each other. The protons are all positive, and so repel each other by the electromagnetic force. The neutrons are neutral, and so are not affected by the electromagnetic force. Both protons and neutrons are subjected to another force: the strong nuclear force. This force is attractive, and stronger than the electromagnetic force, but has a very short effective range. The protons within a nucleus repel each other within one force, while they attract each other with another. These forces may result in an equilibrium state, in which case the particles remain in the nucleus. A nucleus that contains nucleons in a sustained equilibrium state is said to be **stable**.

**Class Discussion**

A brief historical review of the model of the atom will help set the context for the study of medical physics.

**Demonstration**

Students build models of different atoms using Styrofoam spheres and toothpicks.

**Visual Display**

Students draw Bohr atoms of various elements using neutral atoms with atomic numbers from 1 to 20.

Students draw the Bohr model of an ion formed by the element.

Students draw the Bohr model of an isotope of the element.



**GENERAL LEARNING OUTCOME CONNECTION**

*Students will...*

Describe scientific and technological developments, past and present, and appreciate their impact on individuals, societies, and the environment, both locally and globally (GLO B1)

**SPECIFIC LEARNING OUTCOMES**



**S4P-4-2: Define radioactivity as a nuclear change that releases energy.**

Include: Becquerel units, radioactive decay, half life

**S4P-4-3: Perform decay calculations using integer numbers of half life.**

**SUGGESTIONS FOR INSTRUCTION**

**Entry Level Knowledge**

Although this learning outcome limits the analysis to integer numbers of half life, students who have completed Senior 4 Pre-Calculus Mathematics or Senior 4 Applied Mathematics will have seen exponential functions, including radioactive decay.

**Notes to the Teacher**

The forces acting on the particles of the nucleus can result in a loss of equilibrium. A nucleus in such a state will undergo a change, which is referred to as **radioactive decay**. Nuclei that undergo radioactive decay spontaneously are said to be unstable. Radioactive decay releases energy, and may also change the composition of the nucleus. A sample of unstable nuclei is said to have an activity, measured in the unit of Becquerel (Bq), which is one decay per second. Although unstable nuclei will certainly decay, the timing of the decay cannot be predicted and so it is said to be random. As an example, a sample of material that undergoes 100 decays per second would be said to have an activity of 100 Becquerels.

As with the toss of a coin, the outcome of a single event is unknown, but large numbers of events can be described accurately. One measure of the longevity of an unstable isotope is that of a half life, which is the length of time needed for half of the nuclei in a large sample to decay. As an example, the half life of Iodine-131 is about 8 days. This means that if a sample consisted of 1 kg of Iodine-131, then after 8 days, only 0.5 kg of Iodine-131 would remain (note that the sample would still be nearly 1 kg, but the remaining 0.5 kg would no longer be Iodine-131). After 16 days (two half lives), the sample would contain about 0.25 kg of Iodine-131. Note that 1 kg of Iodine-131 consists of approximately  $4.6 \times 10^{24}$  atoms, which makes the statistical predictions quite accurate.



**SKILLS AND ATTITUDES OUTCOMES**

**S4P-0-2c:** Formulate operational definitions of major variables or concepts.

**S4P-0-2d:** Estimate and measure accurately using SI units.

**GENERAL LEARNING OUTCOME CONNECTION**

*Students will...*

Understand the composition of the universe, the interactions within it, and the impacts of humankind’s continued attempts to understand and explore it (GLO D6)

**SUGGESTIONS FOR INSTRUCTION**

**Class Activity**

Obtain about 200 (or more) pennies and distribute them among the students. Initially, each penny represents an unstable nucleus. Have the students each shake their pennies in a cup and then invert the cup so that each penny lies flat. A penny that comes up heads represents a nucleus that has decayed (and assumed to now be stable), and a penny that comes up tails represents a nucleus that has not yet decayed—it is still unstable. Obtain the total number of pennies that come up tails—this is the number of unstable nuclei—and place them back inside the cups. (Set aside the pennies that have come up heads. They have decayed, and so are “out of the game.”) Repeat this several times until the number of pennies that remains in the game is less than 20, and graph the results: Number of unstable nuclei versus toss number. Statistically, we expect approximately half of the coins to “decay” each toss. The “half life” for the pennies is the amount of time to go through the process described above.

**Student Activity**

See “Get a Half Life” activity in Appendix 4.1.

**SUGGESTIONS FOR ASSESSMENT**

**Pencil-and-Paper Tasks**

Students graph sample data for radioactive decay.

Students solve a variety of half-life problems.

**Laboratory Report**

Students report on the penny simulation lab as if it were a radioactive example. Include safety considerations for radioactive materials.

**SUGGESTED LEARNING RESOURCES**

BLM 39-1: Conceptual-Development Practice, Radioactive Half Life, *Conceptual Physics*, Pearson, 2002

Appendix 4.1: “Get a Half Life”

*The Best From Conceptual Physics Alive!* DVD Series: Episode 33—Radioactivity, Call #6017



**GENERAL LEARNING OUTCOME CONNECTION**

*Students will...*

Understand the composition of the universe, the interactions within it, and the impacts of humankind's continued attempts to understand and explore it (GLO D6)

**SPECIFIC LEARNING OUTCOME**



**S4P-4-4: Describe the following types of radiation: alpha, beta, and electromagnetic radiation.**

Include: particle radiation, wave radiation, electromagnetic spectrum, linear energy transfer

**SUGGESTIONS FOR INSTRUCTION**

**Entry Level Knowledge**

The Bohr model of the atom was introduced in Senior 1 Science. In addition, the four fundamental forces were introduced in Senior 3 Physics.

**Notes to the Teacher**

When a nucleus decays, it releases energy. This energy may be in the form of particles (which possess kinetic energy) or waves. Alpha particles are literally fragments of the nucleus, being made of two protons and two neutrons (they are, in fact, identical to the nucleus of a Helium-4 atom). An isotope that releases alpha particles is described as an **alpha emitter**, and the process of ejecting an alpha particle from the nucleus is **alpha decay**. The remainder of the original nucleus is referred to as the **daughter nucleus**, which has two fewer protons and two fewer neutrons (its elemental identity is therefore changed) compared to the parent nucleus, and may itself be unstable. As an example, Uranium-238 undergoes alpha decay, resulting in a daughter nucleus, which is Thorium-234.

**Beta decay** is the name given to the process of the nucleus ejecting a beta particle. Beta particles are identical to electrons. The complication that arises is that there were no electrons in the nucleus to begin with. The ejected beta particle is in fact created in the process in which a neutron in the nucleus is converted into a proton. This process

may suggest that a neutron is merely a proton and an electron merged together, but this is not the case. In the subatomic realm, particle creation and particle annihilation are commonplace. As an example, Carbon-14 undergoes beta decay, resulting in a daughter nucleus, which is Nitrogen-14.

Another possibility is that the particles of the nucleus do not change in terms of their actual makeup, but rather settle into a lower energy state, releasing the energy as electromagnetic radiation (i.e., **gamma rays**). Gamma rays are essentially a higher energy form of visible light, and are parts of what is generally referred to as **electromagnetic waves**. The electromagnetic spectrum is the family of all electromagnetic waves, which are identified by frequency and wavelength. The constituents of the electromagnetic spectrum in order of increasing energy, increasing frequency, and decreasing wavelength, are: radio waves, microwaves, infrared, visible light, ultraviolet light, X-rays, and gamma rays.

At this point, inclusion of a diagram of the electromagnetic spectrum, followed by a discussion with students, would be appropriate.



**SKILLS AND ATTITUDES OUTCOMES**

**S4P-0-2c:** Formulate operational definitions of major variables or concepts.

**S4P-0-4b:** Work co-operatively with a group to identify prior knowledge, initiate and exchange ideas, propose problems and their solution, and carry out investigations.

**GENERAL LEARNING OUTCOME CONNECTION**

*Students will...*

Understand the composition of the universe, the interactions within it, and the impacts of humankind's continued attempts to understand and explore it (GLO D6)

**SUGGESTIONS FOR INSTRUCTION**

**SUGGESTIONS FOR ASSESSMENT**

**Prior Knowledge Activity**

Students collaborate and enter into their science journal real-life stories of medical treatments using radiation.

**Student Activity**

Students use Three-Point Approach concept frames (SYSTH) to detail the characteristics of alpha, beta, and gamma radiation.

Students use compare/contrast frames (SYSTH) to compare different forms of radiation.

**SUGGESTED LEARNING RESOURCES**

BLM 68-1: The Bohr Atom, *Physics: Concepts and Connections*, Irwin Publishing Ltd., 2003

BLM 39-2: Conceptual-Development Practice, Nuclear Reactions, *Conceptual Physics*, Pearson, 2002

Appendix 4.2: Alpha Decay

Appendix 4.3: Beta Decay

Appendix 4.4: Gamma Radiation



**GENERAL LEARNING OUTCOME CONNECTION**

*Students will...*

Understand the properties and structures of matter as well as various common manifestations and applications of the actions and interactions of matter (GLO D3)

**SPECIFIC LEARNING OUTCOME**



**S4P-4-5: Compare and contrast sources and characteristics of ionizing radiation and non-ionizing radiation.**

Include: NORM (Naturally Occurring Radioactive Materials), radon, background radiation, incandescent light bulb, hot objects

**SUGGESTIONS FOR INSTRUCTION**

**Entry Level Knowledge**

None.

**Notes to the Teacher**

Some students may have the belief that “radiation” is dangerous and should be avoided. While radiation can be dangerous, it is impossible to avoid and is not necessarily dangerous. Many common materials in our environment are naturally radioactive—they contain isotopes that are unstable. Everything from the air we breathe, to the foods we eat, to the Earth we live on is radioactive. In addition to these terrestrial sources, we are constantly bathed in radiation that comes from space, including from our own Sun.

Radiation of all forms can be generally described as ionizing or non-ionizing. After it has been released from the nucleus, the various forms of radiation can interact with matter. In particular, the radiation can interact with the electrons that surround a neutral atom. If the radiation has sufficient energy, it can remove the electron from its parent nucleus, leaving a charged ion and a free electron—in which case the radiation is identified as **ionizing**. If the radiation does not have sufficient energy to cause the ionizing, it is identified as **non-ionizing**.

If the term **radiation** is used in the most general sense, virtually everything is a source of radiation. In particular, all objects emit electromagnetic radiation of a type and amount that depend on the temperature of the object. At room temperature, objects mostly emit infrared (non-ionizing) radiation. At higher temperatures, they additionally emit visible light

(non-ionizing) radiation. For example, the filament of an incandescent light bulb is designed to emit visible light by reaching a sufficiently high temperature.

One source of radiation of particular concern is that of radon. Uranium is found in very small amounts in virtually all soil. Uranium undergoes a series of decay events, with one of the eventual isotopes produced being Radon-222. Radon is a noble gas, and so does not react chemically. Being a gas, it seeps out of the soil and enters the atmosphere, at which point it can be inhaled. While in the lungs, it may decay (it is an alpha emitter), subjecting the lungs to alpha radiation. Furthermore, the daughter products of this decay are also radioactive, not inert, and can interact with the lining of the lung, where they will remain.

**Demonstration**

Thomas A. Walkiewicz, Collection of Radon Daughter Products, *Physics Teacher* 33 (1995): 345.

**Summary**

Ionizing radiation is radiation consisting of particles (such as  $\alpha$  or  $\beta$  particles, fast-moving neutrons) or high-energy electromagnetic waves (such as  $\gamma$ -rays, X-rays, high-energy UV rays) that have sufficient energy to knock electrons out of atoms and molecules, and create ions.

There are several sources of radiation in our environment. These include background radiation from cosmic rays, radioactive nuclei in our own bodies, radioactive particles in the Earth and in the air around us, and radon found in the soil and rocks.





**SKILLS AND ATTITUDES OUTCOMES**

**S4P-0-2i:** Select and integrate information obtained from a variety of sources.

Include: print, electronic, specialists, or other resource people

**S4P-0-4e:** Demonstrate a continuing and more informed interest in science and science-related issues.

**GENERAL LEARNING OUTCOME CONNECTION**

*Students will...*

Understand the properties and structures of matter as well as various common manifestations and applications of the actions and interactions of matter (GLO D3)

**SUGGESTIONS FOR INSTRUCTION**

There are several man-made sources of radiation. Examples are radioactive sources in consumer products like the mantle of gas lanterns, smoke detectors, and the radiation we may be exposed to through medical procedures.

Radiation can damage the cells of biological organisms. The ions produced during ionization can interfere with chemical reactions in the cell. Ionization can break apart molecules in the cell so it cannot function in a normal way, or it may be completely destroyed. If the DNA of a cell is damaged, the materials of the cell cannot be properly produced. This may cause the cell to die or defective cells may be produced, leading to cancer. High doses of radiation may lead to radiation sickness (nausea, fever, loss of body hair, etc.). Damage to the DNA in reproductive cells may lead to mutations that are transmitted to future generations.

Non-ionizing electromagnetic radiation has several uses: low-frequency radio and television waves are used in communication; microwaves are used in satellite communication, radio astronomy, microwave ovens, and diathermy machines; and infrared radiation is used in remote control units, motion detectors, heat lamps, satellites for examining crop diseases and detecting missile launchers, thermographs for the detection of brain tumours and cancers, and infrared telescopes.

**SUGGESTIONS FOR ASSESSMENT**

Students use compare/contrast frames (SYSTH) to compare ionizing and non-ionizing forms of radiation.

**SUGGESTED LEARNING RESOURCES**

<[www.eco-usa.net/toxics/index.shtml](http://www.eco-usa.net/toxics/index.shtml)> (Look under “Other compounds” for Radon)

Visible light is used to expose photographic film and to treat premature infants who may have developed jaundice. It is needed for photosynthesis to occur. Because visible light may be energetic enough to break apart some delicate chemical bonds, some substances are stored in dark bottles.

Ultraviolet light causes tanning and sunburn, and prolonged exposure can cause wrinkles, liver spots, actinic keratosis, and cancer. It can inhibit the immune system and can kill micro-organisms. Ultraviolet light is largely filtered out as it passes through our atmosphere.



**GENERAL LEARNING OUTCOME CONNECTION**

*Students will...*

Recognize both the power and limitations of science as a way of answering questions about the world and explaining natural phenomena (GLO A1)

**SPECIFIC LEARNING OUTCOME**



**S4P-4-6: Describe various applications of non-ionizing radiation.**

*Examples: communications, microwave oven, laser, tanning bed*

**SUGGESTIONS FOR INSTRUCTION**

**Notes to the Teacher**

Radiation plays an important and varied role in our everyday lives. Some applications of radiation, such as communications and microwave ovens, are perceived as useful. Other applications, such as food irradiation, are controversial, and others, such as sunburn and radiation therapy, have major medical consequences. These outcomes are ideal for independent student research. Students should be able to explain the basic physics from their research, identify both sides of controversial issues, and address societal concerns.

**Non-ionizing Radiation: Radio Waves to Infrared Waves**

Electromagnetic (EM) radiation with a high energy ( $\gamma$ -rays, X-rays, high-energy UV rays) has the ability to ionize atoms and molecules, but EM waves with a low energy do not. The electromagnetic spectrum has traditionally been divided into seven or so regions that tend to overlap. The EM waves with the longest wavelength, the lowest frequency, and the lowest energy are the radio waves. In order of increasing energy, the spectrum continues with microwaves, infrared, visible light, ultraviolet light, X-rays, and finally  $\gamma$ -rays. The low-energy EM waves have various applications.

The lowest-frequency electromagnetic waves of practical importance are radio and television waves. The radios we listen to are most often either AM (amplitude modulation) or FM

(frequency modulation). The frequency range for AM waves is 545 kHz to 1605 kHz. The frequencies of FM radio waves lie between 88 MHz and 108 MHz. Television channels 2 to 6 utilize electromagnetic waves with frequencies between 54 and 88 MHz, while channels 7 to 13 use frequencies between 174 and 216 MHz.

The frequency region from about 109 Hz, 1 gigahertz (1 GHz) up to roughly  $3 \times 10^{11}$  Hz is in the domain of microwaves. Microwaves can penetrate the Earth's atmosphere and this makes them especially useful for space-vehicle communications and radio astronomy. Microwaves are used to communicate through the use of satellites, and therefore are useful in telephone or cell phone technology. Airplanes communicate with each other and with ground stations using microwaves. Television stations that communicate with each other do so through microwaves.

Water molecules absorb microwave radiation, causing them to vibrate back and forth. This vibrational energy is rapidly converted to thermal energy, and the water heats up. This is what happens in a microwave oven. The object to be heated must contain water, so a dry paper plate will remain quite cool. In a similar way, the diathermy machine can be used to warm muscles and joints to relieve soreness.



**SKILLS AND ATTITUDES OUTCOMES**

**S4P-0-2d:** Estimate and measure accurately using SI units.

**S4P-0-2i:** Select and integrate information obtained from a variety of sources.

Include: print, electronic, specialists, or other resource people

**S4P-0-3a:** Analyze, from a variety of perspectives, the risks and benefits to society and the environment when applying scientific knowledge or introducing technology.

**GENERAL LEARNING OUTCOME CONNECTION**

*Students will...*

Recognize that scientific and technological endeavours have been and continue to be influenced by human needs and the societal context of the time (GLO B2)

**SUGGESTIONS FOR INSTRUCTION**

The infrared band merges with microwaves at around 300 GHz ( $10^9$  Hz, 1.0 mm wavelength) and extends to about 385 THz ( $10^{12}$  Hz, 780 mm wavelength). Infrared radiation is really heat radiation. One application of infrared radiation in the communications field is its use as a television remote control unit. Infrared devices can also be used as motion detectors and therefore as security devices. Another application of infrared radiation is in the use of heat lamps that can be used in physical therapy to treat sore muscles. Photographic films that are sensitive to infrared radiation can produce pictures, known as thermographs, which show temperature distribution in a part of the body and therefore any abnormal blood flow. They can help in the detection of brain tumours and breast cancer. Satellites that can detect infrared radiation can look out for crop diseases and rocket launchers. Infrared telescopes are used to scan the sky.

**Student Research**

Students use a jigsaw approach to investigate the applications and effects of radiation. Divide the class into “expert” groups. The expert groups each research a different topic. Groups are re-formed with an “expert” from each of the groups. The “expert” presents his or her research to the rest of the group in a collaborative exchange of ideas.

Students interview medical technologists, doctors, dentists, and research scientists about the use of radiation in their careers.

**SUGGESTIONS FOR ASSESSMENT**

**Visual Display**

Students create posters on the applications and effects of radiation. Students prepare a Gallery Walk for other students, teachers, and parents.

**Research Report/Presentation**

Students can work in small groups to prepare a report on the applications of non-ionizing and ionizing radiation. Students can include an analysis of the benefits to, and possible harmful effects on, humans.

Students can research and report on each type of medical technology (imaging and/or treatment).

**Rubrics/Checklists**

Develop a rubric/checklist in collaboration with the students to guide students during the research and presentation of their reports.

**SUGGESTED LEARNING RESOURCES**

Appendix 4.5: Radioisotopes and Their Use in the Diagnosis or Treatment of Illness



**GENERAL LEARNING OUTCOME CONNECTION**

*Students will...*

Describe scientific and technological developments, past and present, and appreciate their impact on individuals, societies, and the environment, both locally and globally (GLO B1)

**SPECIFIC LEARNING OUTCOME**

**S4P-4-7: Describe various applications of ionizing radiation.**

*Examples: food irradiation, sterilization, smoke alarm*



**SUGGESTIONS FOR INSTRUCTION**

**Notes to the Teacher**

**Applications of Ionizing Radiation**

One of the practical applications of the use of ionizing radiation is in a smoke detector. The detector makes use of the alpha decay of the artificial radioactive isotope  $^{241}_{95}\text{Am}$ . In this type of smoke detector, a minute quantity of  $^{241}_{95}\text{Am}$  is placed between two metal plates connected to a battery or other source of emf. The  $\alpha$  particles emitted by the source ionize the air, allowing a measurable electric current to flow between the plates. As long as this current flows, the smoke detector remains silent. When smoke enters the detector, however, the ionized air molecules tend to stick to the smoke particles and become neutralized. This reduces the current and triggers the alarm. These “ionization” smoke detectors are more sensitive than the “photoelectric” detectors that rely on the thickness of smoke to dim a beam of light.

Ionizing radiation can also be used to irradiate food. The radiation can destroy insects and parasites in grains, dried beans, dried fruits and vegetables, and meat and seafood. It can decrease the numbers of micro-organisms in foods. Hence, the incidence of food-borne illness and disease can be decreased. The radiation can also be used to increase the shelf life of food by inhibiting sprouting in crops such as potatoes and onions, and delay the ripening of fresh fruits and vegetables. The sources of the radiation can be isotopes of cobalt,  $^{60}_{27}\text{Co}$ , or cesium  $^{137}_{55}\text{Cs}$ , or from particle accelerators that produce controlled amounts of beta rays or X-rays on food.

Because ionizing radiation can destroy micro-organisms, it can also be used to sterilize medical equipment. Cobalt or cesium isotopes or particle accelerators are used for this purpose.



**SKILLS AND ATTITUDES OUTCOMES**

**S4P-0-3b:** Describe examples of how technology has evolved in response to scientific advances and how scientific knowledge has evolved as the result of new innovations in technology.

**S4P-0-3c:** Identify social issues related to science and technology, taking into account human and environmental needs and ethical considerations.

**GENERAL LEARNING OUTCOME CONNECTION**

*Students will...*

Recognize safety symbols and practices related to scientific and technological activities and to their daily lives, and apply this knowledge in appropriate situations (GLO C1)

**SUGGESTIONS FOR INSTRUCTION**

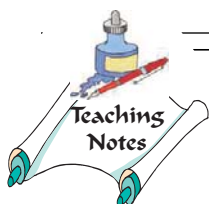

**SUGGESTIONS FOR ASSESSMENT**

Students use compare/contrast frames (SYSTH) to compare ionizing and non-ionizing forms of radiation.

**SUGGESTED LEARNING RESOURCES**

<[www.eco-usa.net/toxics/index.shtml](http://www.eco-usa.net/toxics/index.shtml)> (Look under “Other compounds” for Radon)



**GENERAL LEARNING OUTCOME CONNECTION**

*Students will...*

Identify the factors that affect health and explain the relationships among personal habits, lifestyle choices, and human health, both individual and social (GLO B3)

**SPECIFIC LEARNING OUTCOME**



**S4P-4-8: Describe the effects of non-ionizing and ionizing radiation on the human body.**

Include: equivalency of sievert (Sv) and rem units, solar erythema (sunburn)

**SUGGESTIONS FOR INSTRUCTION**

**Notes to the Teacher**

**Radiation Damage in Biological Organisms**

Radiation can damage the cells of biological organisms. There are various ways in which this damage can occur.

When the atoms and molecules are ionized, ions (also called radicals) are produced. These ions are highly reactive and take part in chemical reactions that interfere with the normal operation of the cell. Also, when electrons are knocked out of molecules, it may cause the molecule to break apart. The structure of the molecule may be altered so that it does not perform its normal function, or it may perform a harmful function. In the case of proteins, the loss of one molecule is not serious if there are other copies of that particular one in the cell, and the cell can make additional ones. However, large doses of radiation may damage so many molecules that new copies cannot be made quickly enough and the cell dies.

Ionizing radiation may also damage the DNA in the cell. It is the DNA that provides a code that allows the production of proteins and other materials for the cell. If the DNA is damaged, these materials may not be made at all and the cell may die. In most cases, the death of a single cell is not a problem, since the body can replace it with a new one. (There are some exceptions, such as neurons, which may not be replaceable, so their loss is serious.) But if many cells die, the organism may not be able to recover. On the other hand, the cell may survive but be defective. It may go on dividing and produce more defective cells

to the detriment of the whole organism. Cancer is caused when defective cells are rapidly produced.

Radiation damage to biological organisms is often divided into categories according to its location in the body: “somatic” and “genetic.” Somatic damage refers to any part of the body except the reproductive organs. Somatic damage affects that organism and may cause cancer. At high doses, radiation may cause radiation sickness. Nausea, vomiting, fever, diarrhea, fatigue, a loss of body hair, or even death characterize radiation sickness. The severity of radiation sickness is related to the dose received. Genetic damage refers to damage to reproductive cells and so affects the individual’s offspring. Damage to the DNA and the genetics of the reproductive cells results in mutations, the majority of which are harmful. These mutations are transmitted to future generations.

**Visible Light to Ultraviolet Light: Non-ionizing and Ionizing Effects in Humans**

Visible light ranges in wavelength from approximately 400 nm for violet light to 700 nm for red light. Some white light is energetic enough to produce chemical reactions. Light can break up delicate chemical bonds, so dark bottles protect substances like aspirin and wine. Light-sensitive photographic films are commonplace. Premature infants may develop jaundice, due to an excess of bilirubin in the blood. This condition can be successfully treated by exposing them to light, since blue-light has enough energy to dissociate the bilirubin molecule. The process of photosynthesis requires light. Photosynthesis removes 200 thousand



**SKILLS AND ATTITUDES OUTCOMES**

**S4P-0-4b:** Work co-operatively with a group to identify prior knowledge, initiate and exchange ideas, propose problems and their solution, and carry out investigations.

**S4P-0-4c:** Demonstrate confidence in their ability to carry out investigations in science and to address STSE issues.

**GENERAL LEARNING OUTCOME CONNECTION**

*Students will...*

Recognize safety symbols and practices related to scientific and technological activities and to their daily lives, and apply this knowledge in appropriate situations (GLO C1)

**SUGGESTIONS FOR INSTRUCTION**

**SUGGESTIONS FOR ASSESSMENT**

million tons of carbon yearly from the atmosphere and produces many complex organic molecules.

Ultraviolet rays have a wavelength range of approximately 400 nm to 12.5 nm. UV light controls some dermatological conditions, such as tanning, activating the synthesis of Vitamin D. At wavelengths of approximately 300 nm and below, UV rays can cause sunburn as well as tanning. Interestingly, UV rays at this wavelength have the energy needed to break carbon-carbon bonds. Much of this radiation is filtered out as it passes through the atmosphere, especially in the higher latitudes and at low-sun angles that occur in winter and in the early and late parts of the day. The ozone layer (O<sub>3</sub> molecules) helps to absorb some of the UV radiation. UV radiation below 300 nm can damage or destroy nucleic acids and proteins, both of which are strong absorbers of UV rays. Extended exposure to UV rays can, in time, cause wrinkles, liver spots, actinic keratosis (pre-cancerous dark blotches), and finally cancer. UV rays can also inhibit the immune system, which may explain why some viral diseases, such as fever blisters and chicken pox, get more severe when the person is exposed to sunshine. Some materials reflect UV light as much as they reflect visible light, so long exposure while near snow or water can be hazardous. The same is true for lying about on a beach on a totally overcast summer day, since water vapour passes a good deal of UV rays. In contrast, ordinary window glass can stop the passage of UV rays. For UV rays at wavelengths less than 290 nm, the energy can ionize an atom or break apart a chemical bond. These kinds of UV rays are germicidal—that is, they kill microorganisms.

Students use compare/contrast frames (SYSTH) to compare ionizing and non-ionizing forms of radiation.

**SUGGESTED LEARNING RESOURCES**

<[www.eco-usa.net/toxics/index.shtml](http://www.eco-usa.net/toxics/index.shtml)> (Look under “Other compounds” for Radon)



**GENERAL LEARNING OUTCOME CONNECTION**

*Students will...*

Identify and appreciate contributions made by women and men from many societies and cultural backgrounds toward increasing our understanding of the world and in bringing about technological innovations (GLO A4)

**SPECIFIC LEARNING OUTCOME**

**S4P-4-9: Research, identify, and examine the application of radiation to diagnostic imaging and treatment techniques.**

*Examples: nuclear medicine imagery techniques such as MRI, ultrasound, endoscopy, X-ray, CT scanning, PET, heavy isotopes such as Ba; nuclear medicine therapies such as brachithery, external beam, gamma knife*



**SUGGESTIONS FOR INSTRUCTION**

**Notes to the Teacher**

**Ultrasound and Medical Imaging**

Ultrasonic sound waves (frequency range from 1 megahertz to 10 megahertz) can be used in medicine for both diagnosis and treatment. In diagnosis, the technique works as follows. A transducer emits a brief pulse of ultrasound. A transducer is a device that transforms an electrical pulse into a mechanical vibration that produces the sound wave. Part of the pulse is reflected at various interface surfaces in the body, and most continue on through the body. The detection of the pulse is done by the same transducer, which transforms the sound pulses into electrical pulses. These pulses can then be displayed on the screen of a cathode-ray tube, such as a display terminal or TV monitor. As an example, consider a sound pulse passing through the abdomen. At various interfaces in the body, part of the pulse is reflected. The time elapsed from when the pulse is emitted to when its reflection (echo) is received is proportional to the distance from the reflecting surface. The strength of a reflected pulse depends mainly on the difference in density of the two materials on either side of the interface. At interfaces involving bones or the lungs, most of the sound pulse is reflected so ultrasound cannot be used as a probe beyond such surfaces.

In the diagnostic use of ultrasound a **pulse-echo technique** is applied. A high-frequency sound pulse is directed into the body, and its reflections

from boundaries or interfaces between organs and other structures and lesions in the body are then detected. By using this technique, tumours and other abnormal growths, or pockets of fluid, can be distinguished. The action of heart valves and the development of a foetus can be examined. Information about various organs of the body, such as the brain, heart, liver, and kidneys can be obtained. Although ultrasound does not replace X-rays, for certain kinds of diagnoses, it is more helpful. Some kinds of tissue or fluid are not detected in X-ray photographs, but ultrasound waves are reflected from their boundaries. It is also possible to produce “real-time” ultrasound images as if one were watching a movie of a section of the interior of the body. Furthermore, at low levels of intensity, no adverse effects have been reported, so ultrasound is considered a non-invasive method for probing the body.

Another use of ultrasound in medical diagnosis involves the **Doppler effect**, the change observed in the frequency with which a wave from a given source reaches an observer when the source and the observer are in relative motion. For example, ultrasonic waves reflected from red blood cells can be used to determine the velocity of blood flow. The Doppler flow meter can be used to locate regions where blood vessels have narrowed. The Doppler effect can also be used to determine the movement of the chest of a young foetus and to monitor its heartbeat.





**SKILLS AND ATTITUDES OUTCOMES**

**S4P-0-4d:** Develop a sense of personal and shared responsibility for the impact of humans on the environment, and demonstrate concern for social and environmental consequences of proposed actions.

**S4P-0-4e:** Demonstrate continuing and more informed interest in science and science-related issues.

**GENERAL LEARNING OUTCOMES CONNECTION**

*Students will...*

Describe scientific and technological developments, past and present, and appreciate their impact on individuals, societies, and the environment, both locally and globally (GLO B1)

Demonstrate a knowledge of, and personal consideration for, a range of possible science- and technology-related interests, hobbies, and careers (GLO B4)

**SUGGESTIONS FOR INSTRUCTION**

**SUGGESTIONS FOR ASSESSMENT**

**Endoscopy and Arthroscopic Surgery**

An **endoscope** is a device used to peer the inside of the body, and **endoscopy** is the practice of using such a device. To understand how an endoscope functions, let us briefly review what total internal reflection is. When light passes from a medium with a larger index of refraction into a smaller index of refraction (such as water to air), the refracted light bends away from the normal. The angle of refraction,  $\theta_r$  is greater than the angle of incidence,  $\theta_i$ . As the angle of incidence increases, the angle of refraction also increases. When the angle of incidence reaches a certain angle called the **critical angle**,  $\theta_c$ , the angle of refraction is  $90^\circ$ . Then the refracted angle points along the surface. When the angle of incidence exceeds the critical angle, there is no refracted light. All the incident light is reflected back into the medium from which it came, a phenomenon called **total internal reflection**.

Students use compare/contrast frames (SYSTH) to compare ionizing and non-ionizing forms of radiation.

**SUGGESTED LEARNING RESOURCES**

<[www.eco-usa.net/toxics/index.shtml](http://www.eco-usa.net/toxics/index.shtml)> (Look under “Other compounds” for Radon)

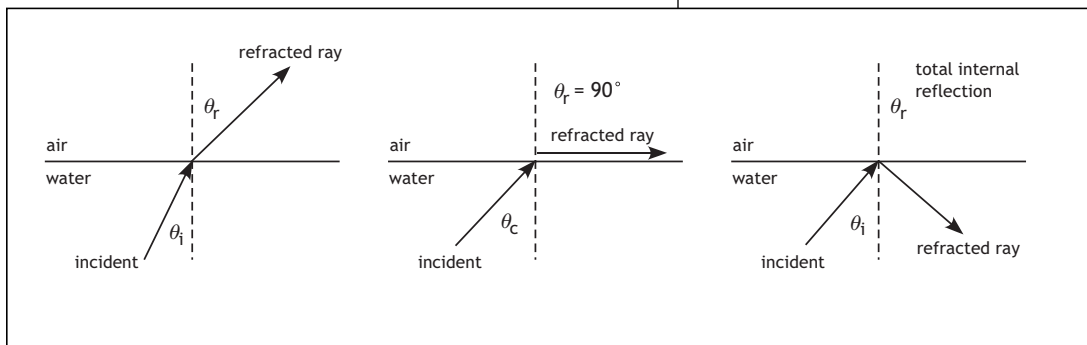

**GENERAL LEARNING OUTCOME CONNECTION**

*Students will...*

Identify and appreciate contributions made by women and men from many societies and cultural backgrounds toward increasing our understanding of the world and in bringing about technological innovations (GLO A4)

**SPECIFIC LEARNING OUTCOME**

**S4P-4-9: Research, identify, and examine the application of radiation to diagnostic imaging and treatment techniques.**

*Examples: nuclear medicine imagery techniques such as MRI, ultrasound, endoscopy, X-ray, CT scanning, PET, heavy isotopes such as Ba; nuclear medicine therapies such as brachithrapy, external beam, gamma knife*



**SUGGESTIONS FOR INSTRUCTION**

An important application of total internal reflection occurs in fibre optics, where hair-thin threads of glass or plastic, called optical fibres, “pipe” light from one place to another. An optical fibre consists of a cylindrical optical *core* that carries the light, and an outer concentric shell, the *cladding*. The core is made from transparent glass or plastic that has a relatively high index of refraction. The cladding is also made of glass, but of a type that has a relatively low index of refraction. Light enters one end of the core, strikes the core/cladding interface at an angle of incidence greater than the critical angle, and therefore, is reflected back into the core. Light, then, travels inside the optical fibre along a zigzag path.

**Summary of Imaging Techniques**

Ultrasound is a high-frequency sound wave produced when a transducer transforms an electrical pulse into a mechanical vibration and then detects the same wave after it has been reflected from interfaces between organs and other structures in the body. In the **pulse-echo technique**, several forms of diagnosis can take place, including the detection of tumours and abnormal growths, pockets of fluid, the action of heart valves, the development of a foetus, and information about various organs in the body. Ultrasound can detect some kinds of tissue and fluid that X-rays cannot. Ultrasound is a non-invasive form of probing the body and has no adverse effects. By using the **Doppler effect**, it is possible to locate regions where blood vessels have

narrowed, and to monitor a foetus. Ultrasonic waves of high intensity can be used to destroy tumours and kidney stones.

**Endoscopy** is the practice of using an **endoscope**, a device used to peer inside the body. The endoscope consists of very thin threads of glass and plastic called **optical fibres**. The fibres are able to pipe light from one place to another through the process of **total internal reflection** which occurs when incident light is reflected back into the medium it came from when the angle of incidence exceeds the **critical angle**. Endoscopes such as the bronchoscope or colonoscope can be inserted into the body to diagnose disease. Optical fibres can also be used in arthroscopic surgery where only a tiny incision is needed, resulting in minimal damage to surrounding tissue.

A **laser** light is produced when excited atoms give off photons that in turn excite other atoms. For every one photon absorbed by an atom, two are emitted. The emitted photons travel in the same direction as the incident photon, and the light waves produced are in phase with each other and the output beam is monochromatic. One of the uses of laser light is a process called **photorefractive keratectomy (PRK)**, where tissues can be removed from the cornea to correct nearsightedness or farsightedness. A **pulsed dye laser** can be used in the treatment of congenital capillary malformations. **Photodynamic therapy** uses lasers to activate drugs that kill cancer cells.



**SKILLS AND ATTITUDES OUTCOMES**

**S4P-0-4d:** Develop a sense of personal and shared responsibility for the impact of humans on the environment, and demonstrate concern for social and environmental consequences of proposed actions.

**S4P-0-4e:** Demonstrate continuing and more informed interest, in science and science-related issues.

**GENERAL LEARNING OUTCOMES CONNECTION**

*Students will...*

Describe scientific and technological developments, past and present, and appreciate their impact on individuals, societies, and the environment, both locally and globally (GLO B1)

Demonstrate a knowledge of, and personal consideration for, a range of possible science- and technology-related interests, hobbies, and careers (GLO B4)

**SUGGESTIONS FOR INSTRUCTION**

**SUGGESTIONS FOR ASSESSMENT**

**X-rays** are a form of electromagnetic radiation produced when electrons are accelerated through a large potential difference and then made to collide with a metal target. When X-rays are directed toward a body, the denser tissue, like bones, absorb more of the radiation, leaving a lighter image on a photographic film or fluorescent screen.

**Computerized axial tomography (CAT)**, also called **computerized tomography (CT)** uses collimated X-rays, detectors, and computer analysis to produce images of body structures and lesions that have a higher resolution than X-rays. Two-dimensional slices or three-dimensional images may be produced.

**Magnetic resonance imaging (MRI)** uses a strong magnetic field to align the nuclei of hydrogen atoms inside the body. Radiofrequency coils produce RF waves that excite the hydrogen nuclei. When the nuclei fall back down to ground state, the RF coils detect the energy and a computer analyzes the signals to produce remarkably detailed images of the human body that can be used in medical diagnosis.



NOTES



---

# ***APPENDICES***

Appendix 1: Mechanics

Appendix 2: Fields

Appendix 3: Electricity

Appendix 4: Medical Physics

Appendix 5: Developing Assessment Rubrics in Science

Appendix 6: Assessment Rubrics

Appendix 7: General Learning Outcomes

Appendix 8: Specific Learning Outcomes

---

# APPENDIX 1: MECHANICS

## Appendix 1.1: Derivations for Constant Motion

### Derivations for Constant Motion

The *position-time* graph for constant motion is a straight oblique line.

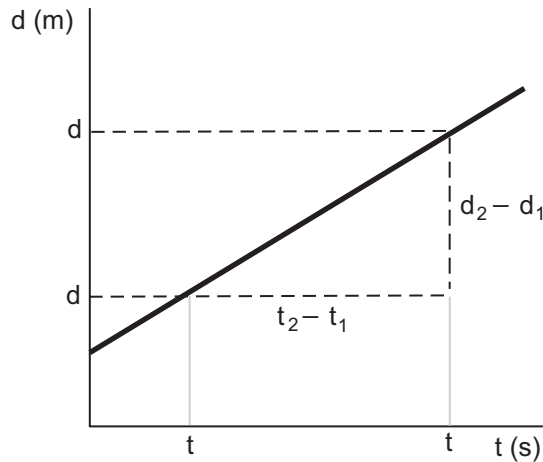

As demonstrated in Senior 3 Physics, to derive average velocity,  $\bar{v} = \frac{\Delta \vec{d}}{\Delta t}$ , find the slope of the position-time graph by the slope formula.

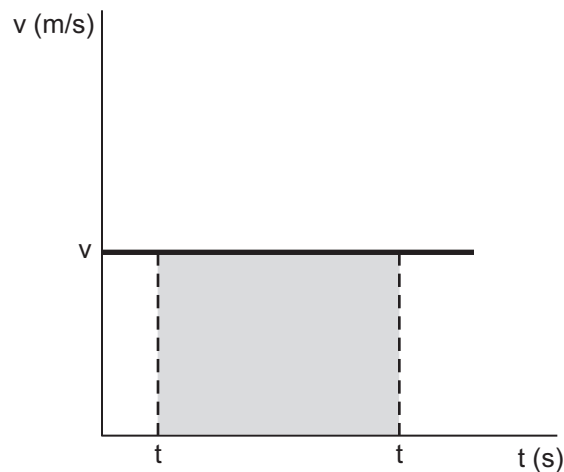

The velocity-time graph for constant motion is a horizontal line. The area between the line and the horizontal axis is a rectangle (Area = length  $\times$  width) and corresponds to the displacement  $\Delta \vec{d} = \vec{v} \Delta t$ .



### Derivations for Accelerated Motion

The *velocity-time* graph for accelerated motion is a straight oblique line.

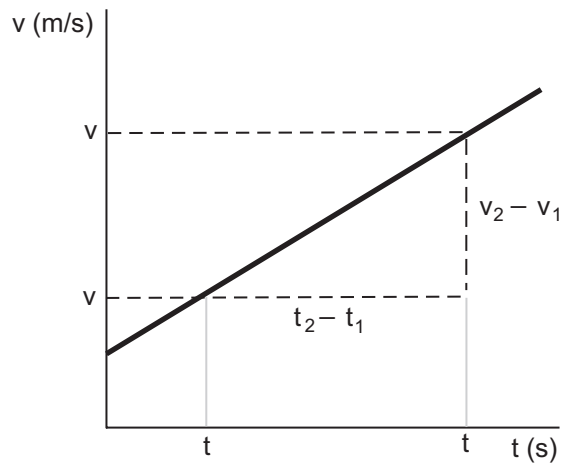

As demonstrated in Senior 3 Physics, to derive average acceleration,  $\bar{a}_{ave} = \frac{\Delta v}{\Delta t}$ , find the slope of the velocity-time graph by the slope formula. The slope of the velocity-time graph

gives  $\bar{a} = \frac{\Delta v}{\Delta t} = \frac{v_2 - v_1}{\Delta t}$ .

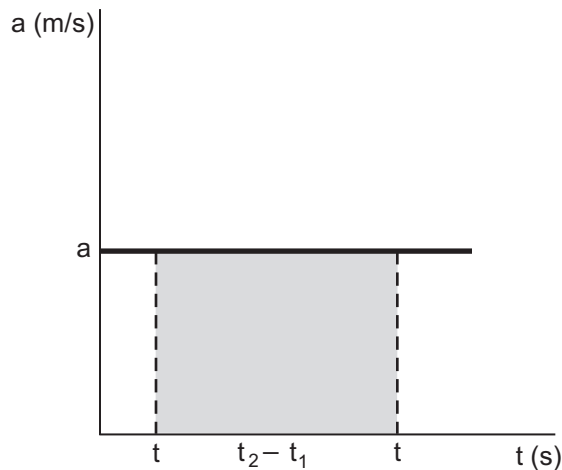

The area between the line and the horizontal axis of the velocity-time graph is a trapezoid and corresponds to the displacement of the object for that time interval. The trapezoid can be divided into a rectangle and a triangle.



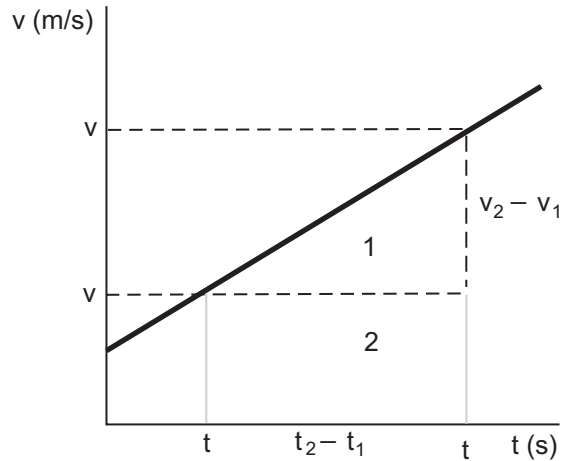

Then the total area and displacement is the sum of these areas.

$\Delta \vec{d} = \text{area of triangle} + \text{area of rectangle}$

$$\Delta \vec{d} = \vec{v}_1 \Delta t + \frac{1}{2} (\vec{v}_2 - \vec{v}_1) \Delta t$$

But  $\vec{v}_2 - \vec{v}_1 = \vec{a} \Delta t$ , so substitute  $\vec{a} \Delta t$  for  $\vec{v}_2 - \vec{v}_1$ , giving

$$\Delta \vec{d} = \vec{v}_1 \Delta t + \frac{1}{2} (\vec{a} \Delta t) \Delta t$$

and

$$\Delta \vec{d} = \vec{v}_1 \Delta t + \frac{1}{2} \vec{a} \Delta t^2$$

The final equation is derived by eliminating  $\Delta t$  from two equations.

The displacement can be found using the average velocity for the interval ( $\Delta d = v_{\text{ave}} \Delta t$ ).

Therefore:

$$1. \Delta \vec{d} = \left( \frac{\vec{v}_1 + \vec{v}_2}{2} \right) \Delta t$$

and

$$2. \vec{v}_2 - \vec{v}_1 = \vec{a} \Delta t$$

Ignore vector notation, since the equations involve the products of vectors.





Solve (1) for  $\Delta t$  to obtain

$$3. \Delta t = \frac{2\Delta d}{v_1 + v_2}$$

Substitute this expression for  $\Delta t$  in (2)

$$a \frac{2\Delta d}{v_1 + v_2} = v_2 - v_1$$

Multiply across and

$$2a\Delta d = (v_2 - v_1)(v_2 + v_1)$$

Therefore,  $2a\Delta d = v_2^2 - v_1^2$

$$\text{Or, } v_2^2 - v_1^2 = 2a\Delta d$$



## Appendix 1.2: Category Concept Map

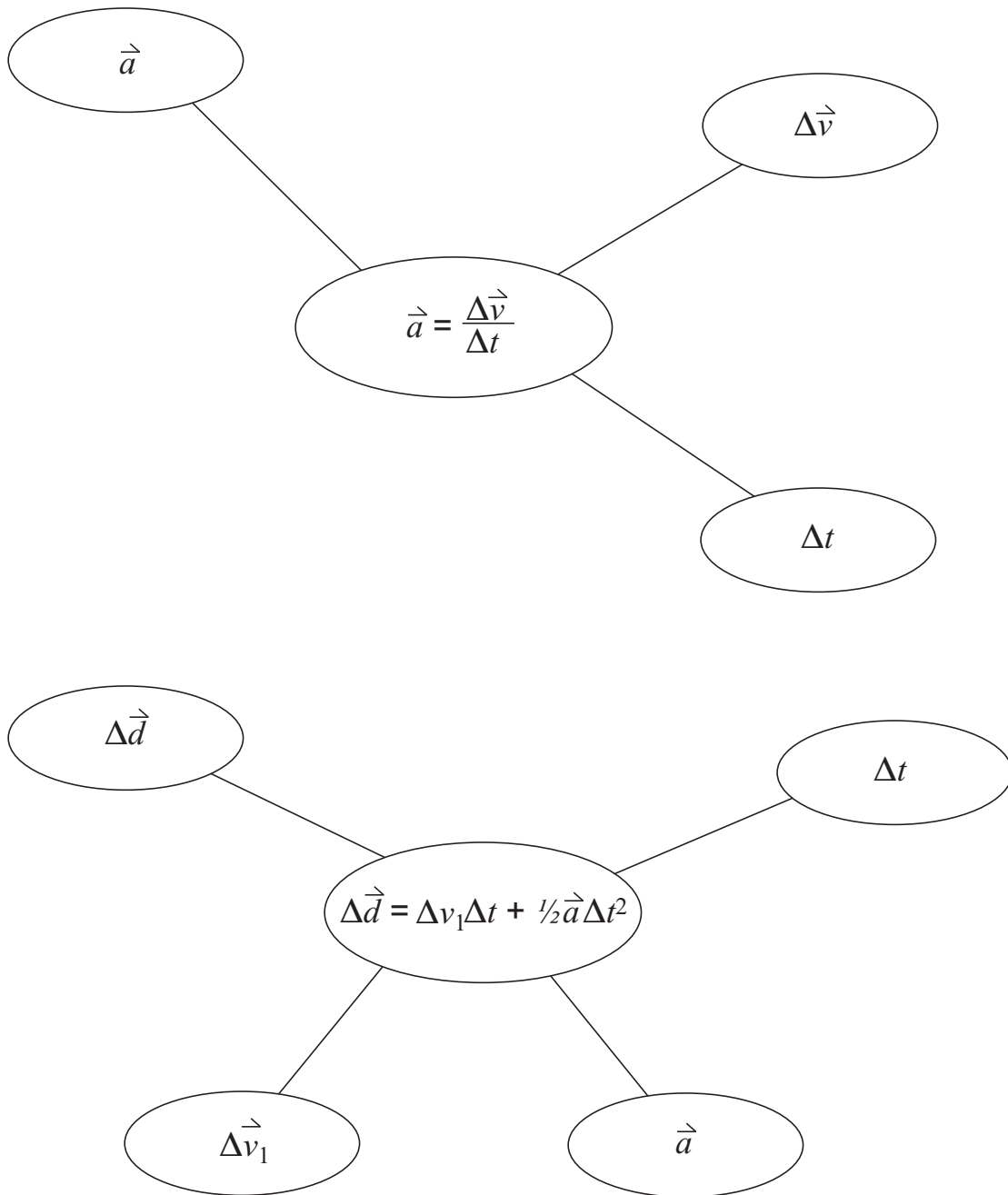

## Appendix 1.3: Kinematics Problem Set

### Sample Problems

**Problem 1:** A dragster accelerates from rest, covering a 400.0 m distance in 8.00 seconds. (The acceleration is constant.)

- Calculate the average acceleration during this time.
- Calculate the final velocity of the dragster.
- Calculate the average velocity of the dragster.
- Calculate the velocity 4.00 seconds after the dragster began to move.
- Compare the displacement of the dragster during the first 4.00 seconds and the last 4.00 seconds of the trip. Account for the difference.

*Solution:*

Identify:

$$\vec{v}_1 = 0 \text{ m/s}$$

$$\Delta \vec{d} = 400.0 \text{ m [right]}$$

$$\Delta t = 8.00 \text{ s}$$

$$\vec{a}_{\text{ave}} = ?$$

The average acceleration can be found by relating the displacement, initial velocity, and the time interval.

$$\Delta \vec{d} = \vec{v}_1 \Delta t + \frac{1}{2} \vec{a} \Delta t^2$$

*Answer:*

$$400 \text{ m [right]} = (0 \text{ m/s})(8.00 \text{ s}) + \frac{1}{2} \left( \vec{a} \text{ m/s}^2 \right) (8.00 \text{ s})^2$$

$$400 \text{ m [right]} = 0 \text{ m} + 32.0 \vec{a} \text{ m/s}^2 (\text{s}^2)$$

$$\vec{a} = 12.5 \text{ m/s}^2 \text{ [right]}$$

$$\vec{v}_1 = 0 \text{ m/s}$$

$$\Delta \vec{d} = 400.0 \text{ m [right]}$$

$$\Delta t = 8.00 \text{ s}$$

$$\vec{a}_{\text{ave}} = 12.5 \text{ m/s}^2 \text{ [right]}$$



Since errors due to significant figures propagate to the next calculations, the given information should be used wherever possible. In this case, relate displacement, time interval, and the initial velocity with the final velocity.

$$\Delta \vec{d} = \left( \frac{\vec{v}_1 + \vec{v}_2}{2} \right) \Delta t$$

Answer:

$$400.0 \text{ m [right]} = \left( \frac{0 + \vec{v}_2}{2} \right) 8.00 \text{ s}$$

$$\frac{400.0 \text{ m [right]}}{8.00 \text{ s}} = \frac{\vec{v}_2}{2}$$

$$50.0 \text{ m/s [right]} = \frac{\vec{v}_2}{2}$$

$$\vec{v}_2 = 100 \text{ m/s [right]}$$

Look back and check. Check your answer with  $\vec{v}_2 = \vec{v}_1 + \vec{a} \Delta t$ .

$$\vec{v}_1 = 0 \text{ m/s}$$

$$\Delta \vec{d} = 400.0 \text{ m [right]}$$

$$\Delta t = 8.00 \text{ s}$$

$$\vec{a}_{\text{ave}} = 12.5 \text{ m/s}^2 \text{ [right]}$$

$$\vec{a}_{\text{ave}} = ?$$

Since the acceleration is constant, the initial and final velocities can simply be averaged.

$$\left( \frac{\vec{v}_1 + \vec{v}_2}{2} \right) = \vec{v}_{\text{ave}}$$

Answer:

$$\left( \frac{0 \text{ m/s} + 100 \text{ m/s [right]}}{2} \right) = \vec{v}_{\text{ave}}$$

$$\vec{v}_{\text{ave}} = 50.0 \text{ m/s [right]}$$

Look back and check. Check your answer using  $\Delta \vec{d} = \left( \frac{\vec{v}_1 + \vec{v}_2}{2} \right) \Delta t$ .



$$\begin{aligned} \vec{v}_1 &= 0 \text{ m/s} \\ \Delta \vec{d} &= 400.0 \text{ m [right]} \\ \Delta t &= 4.00 \text{ s} \\ \vec{a}_{\text{ave}} &= 12.5 \text{ m/s}^2 \text{ [right]} \\ \vec{v}_2 \text{ at } 4.00 \text{ s} &=? \end{aligned}$$

In this case, relate acceleration, time interval, and the initial velocity with the final velocity.

$$\vec{v}_2 = \vec{v}_1 + \vec{a} \Delta t$$

*Answer:*

$$\begin{aligned} \vec{v}_2 &= 0 \text{ m/s} + (12.5 \text{ m/s}^2 \text{ [right]}) 4.00 \text{ s} \\ \vec{v}_2 &= 50.0 \text{ m/s [right]} \end{aligned}$$

Look back and check. Double check the calculations.

$$\vec{v}_1 = 0 \text{ m/s}$$

### Part I

Time interval 0 s to 4 s

$$\begin{aligned} \Delta t &= 4.00 \text{ s} \\ \vec{a}_{\text{ave}} &= 12.5 \text{ m/s}^2 \text{ [right]} \\ \vec{v}_2 \text{ at } 4.00 \text{ s} &= 50.0 \text{ m/s [right]} \\ \Delta \vec{d} \text{ at } 4.00 \text{ s} &=? \end{aligned}$$

The displacement can be determined using initial velocity, final velocity, and the time interval.

$$\Delta \vec{d} = \left( \frac{\vec{v}_1 + \vec{v}_2}{2} \right) \Delta t$$

*Answer:*

$$\begin{aligned} \Delta \vec{d} &= \left( \frac{0 \text{ m/s} + 50.0 \text{ m/s [right]}}{2} \right) 4.00 \text{ s} \\ \Delta \vec{d} &= (25.0 \text{ m/s [right]}) (4.00 \text{ s}) \\ \Delta \vec{d} &= 100 \text{ m [right]} \end{aligned}$$

Look back and check using  $\Delta \vec{d} = \vec{v}_1 \Delta t + \frac{1}{2} \vec{a} \Delta t^2$ .



**Part II**

Time interval 4.00 s to 8.00 s

During the interval between 4.00 s and 8.00 s, the dragster travels from a position of 100 m [right] to a position 400 m [right] from the starting line. The dragster has travelled 300 m [right] during the last 4.00 s of the trip.

The dragster travelled 100 m [right] during the first 4.00 s. During these 4.00 s, the dragster was accelerating from rest and was moving with a small average velocity. During the second 4.00 s interval, the dragster was travelling at a much larger average velocity. Thus, for equal time intervals, the dragster will travel a greater distance during the time interval with the larger average velocity. Students have a tendency to assume the velocity is constant.

**Problem 2:** A car is travelling along a street. It accelerates from rest at  $3.00 \text{ m/s}^2$  for 4.50 seconds. The car then travels at constant velocity for 12.0 seconds. At this time, the driver spies an amber light at the next intersection, steps on the brake, and brings the car to rest in 3.00 seconds.

- Calculate the final velocity for the first interval.
- Calculate the displacement for the first interval.
- Calculate the displacement for the second interval.
- Calculate the acceleration during the third interval.
- Calculate the displacement for the third interval.
- Determine the total displacement for the entire time interval.

Problem 2 requires that the student separate the motion into appropriate intervals for which the acceleration is constant. Each section is treated separately. The final velocity for one interval becomes the initial velocity of the next interval.

Students are often intimidated by problems that require many steps in their solution. Problems can be presented separated into smaller steps at the beginning of this section. As the students become more proficient at solving problems, more sophisticated questions can be asked.



## Appendix 1.4: Inclined Planes

### Illustrative Example 1

Students should solve problems for objects on inclined planes. For example:

A person in a wheelchair is travelling up an inclined sidewalk. The coefficient of friction is 0.11, and the mass of the person and the wheelchair is 65.0 kg. The degree of incline is  $7^\circ$ . Can the person rest comfortably on the inclined sidewalk, or will this person roll down the incline? Calculate the acceleration if the person cannot rest comfortably on the inclined sidewalk. Support your answer mathematically.

*Solution:*

**Step 1:** Draw a free-body diagram of the situation.

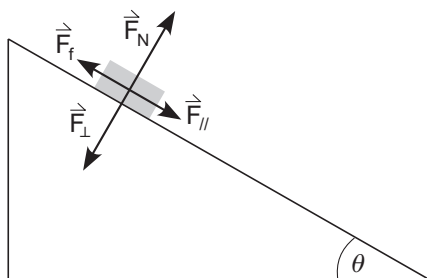

**Step 2:** Calculate the components of  $\vec{F}_g$ .

$$\vec{F}_{gx} = m g \sin \theta$$

$$\vec{F}_{gx} = (65.0 \text{ kg})(9.8 \text{ m/s}^2) \sin 7.0^\circ$$

$$\vec{F}_{gx} = 77.63 \text{ N [down the incline]}$$

$$\vec{F}_{gy} = m g \cos \theta$$

$$\vec{F}_{gy} = (65.0 \text{ kg})(9.8 \text{ m/s}^2) \cos 7.0^\circ$$

$$\vec{F}_{gy} = 632.3 \text{ N [perpendicular to the incline]} = \vec{F}_N \text{ (normal force)}$$

**Step 3:** Calculate the friction.

$$\vec{F}_f = \mu \vec{F}_N$$

$$\vec{F}_f = (0.11)(632.3 \text{ N})$$

$$\vec{F}_f = 69.5 \text{ N}$$



**Step 4:** Calculate the net force.

$$\begin{aligned}\vec{F}_{\text{net}} &= \vec{F}_{\text{gx}} + \vec{F}_f \\ \vec{F}_{\text{net}} &= 77.63 \text{ N} + (-69.5 \text{ N}) \\ \vec{F}_{\text{net}} &= 8.08 \text{ N [down the incline]}\end{aligned}$$

Therefore, the person will not rest comfortably and will start moving down the inclined sidewalk.

**Step 5:** Substitute in the equation,

$$\begin{aligned}a &= \frac{\vec{F}_{\text{net}}}{m} \\ a &= \frac{8.08 \text{ N}}{65.0 \text{ kg}} \\ a &= 0.124 \text{ m/s}^2\end{aligned}$$

### Illustrative Example 2

A skier of mass 75.0 kg is skiing down a ski run that is inclined at an angle of  $30.0^\circ$ . The coefficient of kinetic friction between the skis and the snow is 0.150. Calculate  $\vec{F}_{\text{net}}$ , the acceleration of the skier, the speed the skier obtains after 8.00 s, and the distance traveled during the 8.00 s.

*Solution*

**Step 1:** Draw a picture of the situation and label the diagram.

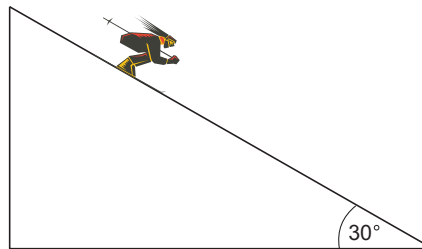



**Step 2:** List the quantities needed for the Dynamics section and the quantities needed for the Kinematics section.

Dynamics	Kinematics
mass = 75.0 kg	$\vec{v}_1 = 0 \text{ m/s}$
$\theta = 30.0^\circ$	$\Delta t = 8.00 \text{ s}$
$\vec{F}_g = m \vec{g}$	
components of $\vec{F}_g$ : $\vec{F}_N$ , $\vec{F}_\parallel$	

### Free-body Diagram

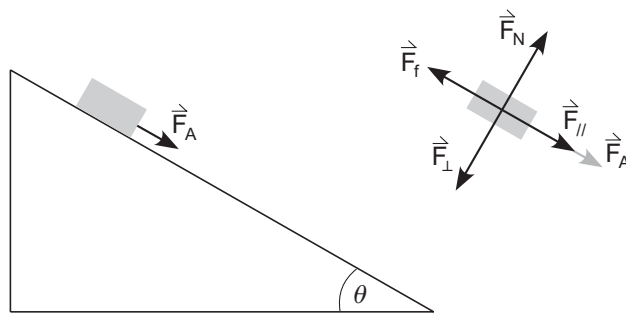

**Step 3:** Solve for various forces.

$$\vec{F}_N = m \vec{g} \cos \theta = (75.0 \text{ kg})(9.8 \text{ m/s}^2)$$

$$\vec{F}_N = 636.5 \text{ N [perpendicular to the incline]}$$

$$\vec{F}_\parallel = m \vec{g} \sin \theta = (75.0 \text{ kg})(9.8 \text{ m/s}^2) \sin 30.0^\circ$$

$$\vec{F}_\parallel = 367.5 \text{ N [down the incline]}$$

$$\vec{F}_f = \mu \vec{F}_N$$

$$\vec{F}_f = 0.150(636.5 \text{ N})$$

$$\vec{F}_f = 95.45 \text{ N}$$

$$\vec{F}_{\text{net}} = \vec{F}_{\text{parallel}} + \vec{F}_N + \vec{F}_\perp + \vec{F}_f$$

$$\vec{F}_{\text{net}} = 367.5 \text{ N [down the incline]} + 636.5 \text{ N [out of surface]} + 636.5 \text{ N [into surface]} + 95.45 \text{ N [up the incline]}$$

$$\vec{F}_{\text{net}} = 272 \text{ N [down the incline]}$$



This answers part (a). To solve for the acceleration, part (b), use:

$$\begin{aligned}\vec{F}_{\text{net}} &= m \vec{a} \\ \vec{a} &= \frac{\vec{F}_{\text{net}}}{m = 272 \text{ N} / 75.0 \text{ kg}} \\ \vec{a} &= 3.63 \text{ m/s}^2 \text{ [down the incline]}\end{aligned}$$

**Step 4:** Now that we know the acceleration, we can now solve for

$$\begin{aligned}\vec{v}_f &= \vec{v}_i + \vec{a} \Delta t \\ \vec{v}_f &= 0 \text{ m/s} + (3.63)(8.00) \\ \vec{v}_f &= 29.0 \text{ m/s [down the incline]}\end{aligned}$$

This solves for part (c).

**Step 5:** Solve for the distance travelled.

$$\begin{aligned}\Delta \vec{d} &= \left( \frac{\vec{v}_1 + \vec{v}_2}{2} \right) \Delta t \\ \Delta \vec{d} &= \frac{0 \text{ m/s} + 29.0 \text{ m/s}}{2} (8.00 \text{ s}) \\ \Delta \vec{d} &= 116 \text{ m [down the incline]}\end{aligned}$$



## Appendix 1.5: Momentum and Impulse

### Illustrative Example

Bullet being fired from a rifle: A gun of mass 3.00 kg fires a bullet with a mass of 19.4 g with a muzzle velocity of 549 m/s. Calculate:

1. the recoil velocity of the gun
2. the impulse applied to the bullet
3. the impulse applied to the gun
4. the average force acting on the bullet if it travelled the length of the barrel distance during  $3.60 \times 10^{-3}$  s.

*Solution:*

1. Draw a set of coordinates and show the initial and final states.

Initial	Final
$m_g = 3.00 \text{ kg}$	$\vec{v}_{2g} = ?$
$m_b = 19.4 \text{ g} = 1.94 \times 10^{-2} \text{ kg}$	$\vec{v}_{2b} = 549 \text{ m/s [right]}$
$\vec{v}_{1g} = 0 \text{ m/s}$	

Since this example illustrates conservation of momentum in one dimension, the vector directions can be labelled right/left or using +/- signs.

$$\begin{aligned} \vec{P}_{\text{total initial}} &= \vec{P}_{\text{total final}} \\ \vec{P}_{1g} + \vec{P}_{1b} &= \vec{P}_{2g} + \vec{P}_{2b} \\ m_g \vec{v}_{1g} + m_b \vec{v}_{1b} &= m_b \vec{v}_{2g} + m_b \vec{v}_{2b} \end{aligned}$$

So, substituting the values into the above equation, we get

$$\begin{aligned} (3.00 \text{ kg})(0 \text{ m/s}) + (1.94 \times 10^{-2} \text{ kg})(0 \text{ m/s}) &= (3.00 \text{ kg}) \vec{v}_{2g} + (1.94 \times 10^{-2} \text{ kg})(549 \text{ m/s [ri} \\ 0 \text{ kg} \cdot \text{m/s} &= (3.00 \text{ kg}) \vec{v}_{2g} + 10.6 \text{ kg} \cdot \text{m/s [right]} \\ (3.00 \text{ kg}) \vec{v}_{2g} &= 10.6 \text{ kg} \cdot \text{m/s [right]} \\ \vec{v}_{2g} &= 3.53 \text{ kg} \cdot \text{m/s [right]} \\ \text{or } \vec{v}_{2g} &= 3.53 \text{ kg} \cdot \text{m/s [left]} \end{aligned}$$



2. Impulse applied to the bullet equals the change in momentum of the bullet.

$$\begin{aligned}\text{Impulse on bullet} &= m_b \Delta \vec{v}_b = m_b \left( \vec{v}_{2b} - \vec{v}_{1b} \right) \\ &= (1.94 \times 10^{-2} \text{ kg})(549 \text{ m/s} - 0 \text{ m/s}) \\ &= 10.6 \text{ kg} \cdot \text{m/s} \text{ [right]} \\ &= 10.6 \text{ N} \cdot \text{s} \text{ [right]}\end{aligned}$$

3. Impulse applied to the gun is equal to, but opposite in direction to, the impulse of the bullet.

$$\begin{aligned}\text{Impulse on gun} &= 10.6 \text{ kg m/s [left]} \\ &= 10.6 \text{ N s [left]}\end{aligned}$$

- d) To calculate the average force, substitute the values into

$$\begin{aligned}\vec{F}_{\text{ave}} &= \frac{\Delta \vec{p}_b}{\Delta t} \\ \vec{F}_{\text{ave}} &= \frac{10.6 \text{ kg} \cdot \text{m/s} \text{ [right]}}{3.60 \times 10^{-3} \text{ s}} \\ \vec{F}_{\text{ave}} &= 2.94 \times 10^3 \text{ N [right]}\end{aligned}$$



## Appendix 1.6: Collisions in Two Dimensions

### Illustrative Example

A curling rock of 18.8 kg is sliding at 1.45 m/s [E]. It collides with a stationary target rock in a glancing fashion. The final velocity of the target rock is 1.00 m/s [30.0 S of E].

Calculate:

1. the total initial momentum and the total final momentum
2. the final momentum of the first rock
3. the final velocity of the first rock (the shooter)
4. the change in momentum of the first rock
5. describe the motion of the centre of mass
6. calculate the impulse applied to the first rock (the shooter)

*Solution:*

- a) Draw a set of coordinate axes and draw a diagram of the situation.

Before collision

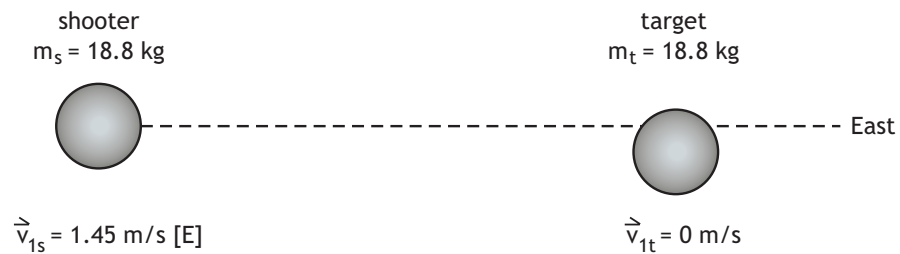

After collision

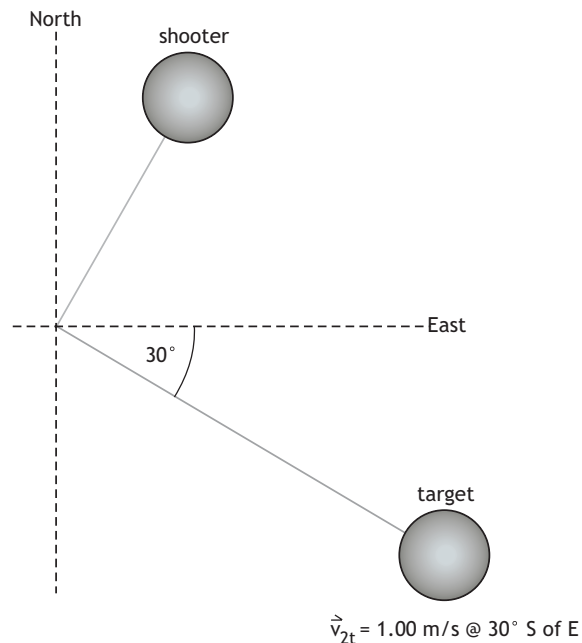

$$\begin{aligned}
 \vec{P}_{\text{initial total}} &= \vec{P}_{\text{initial shooter}} + \vec{P}_{\text{initial target}} \\
 &= m_S \vec{v}_{1S} + m_T \vec{v}_{1T} \\
 &= (18.8 \text{ kg})(1.45 \text{ m/s [E]}) + (18.8 \text{ kg})(0 \text{ m/s}) \\
 &= 27.3 \text{ kg} \cdot \text{m/s [E]}
 \end{aligned}$$

Since momentum is conserved, the total final momentum is the same.

- b) To calculate the final momentum of the first rock, we substitute the values obtained in Part (a) into the following equation:

$$\begin{aligned}
 \vec{P}_{\text{initial total}} &= \vec{P}_{\text{final total}} \\
 \vec{P}_{\text{initial shooter}} + \vec{P}_{\text{initial target}} &= \vec{P}_{\text{final shooter}} + \vec{P}_{\text{final target}} \\
 27.3 \text{ kg} \cdot \text{m/s [E]} &= \vec{P}_{\text{final shooter}} + m_{\text{target}} \vec{v}_{\text{final target}} \\
 27.3 \text{ kg} \cdot \text{m/s [E]} &= \vec{P}_{\text{final shooter}} + (18.8 \text{ m/s})(1.00 \text{ m/s})[30.0^\circ \text{ S of E}] \\
 27.3 \text{ kg} \cdot \text{m/s [E]} &= \vec{P}_{\text{final shooter}} + 18.8 \text{ kg} \cdot \text{m/s [30.0}^\circ \text{ S of E]} \\
 27.3 \text{ kg} \cdot \text{m/s [E]} - 18.8 \text{ kg} \cdot \text{m/s [30.0}^\circ \text{ S of E]} &= \vec{P}_{\text{final shooter}} \\
 27.3 \text{ kg} \cdot \text{m/s [E]} + 18.8 \text{ kg} \cdot \text{m/s [30.0}^\circ \text{ N of W]} &= \vec{P}_{\text{final shooter}}
 \end{aligned}$$

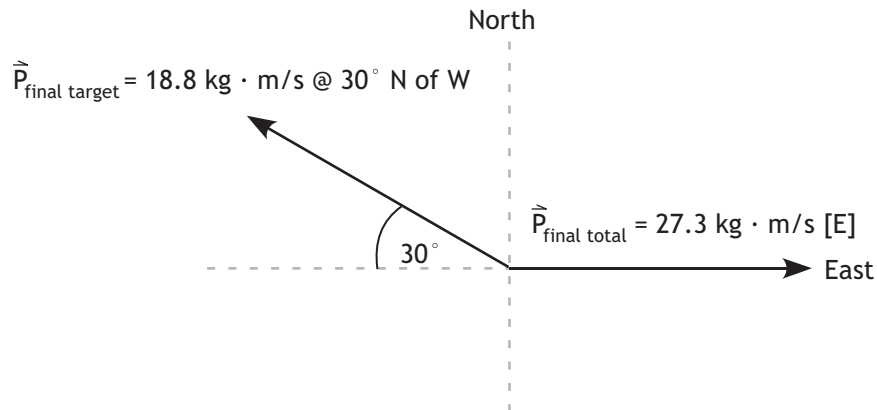

Adding the vector components of the vector diagram shown, we obtain the following data:

	E – W	N – S
$\vec{P}_{\text{final total}}$	27.3 kg · m/s [E]	0 kg · m/s
$\vec{P}_{\text{final T1}}$	16.3 kg · m/s [W]	9.4 kg · m/s [N]
$\vec{P}_{\text{final s}}$	11.0 kg · m/s [E]	9.4 kg · m/s [N]

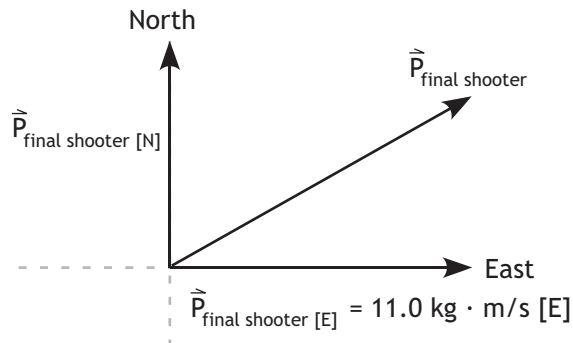

To solve for  $\vec{P}_{\text{final s}}$ , we combine the components from the diagram.

The resultant vector is 14.5 kg · m/s [40.5° N of E].

- c) To solve for the velocity of the shooter rock, substitute values into the following equation:

$$\vec{P}_{\text{final s}} = m_s \vec{v}_{2s}$$

$$14.5 \text{ kg} \cdot \text{m/s} [40.5^\circ \text{ N of E}] = 18.8 \text{ kg} \vec{v}_{2s}$$

$$\vec{v}_{2s} = 0.771 \text{ m/s } 40.5^\circ \text{ N of E}$$

- d) The change in momentum of the shooter can be found by taking the difference between the final momentum and the initial momentum for the shooter. In this case, it would require a subtraction of vector quantities. However, the change in momentum of the shooter is equal but opposite to the change in momentum of the target. This can be easily calculated since the initial momentum of the target stone is 0 kg · m/s.

$$\Delta \vec{p}_s = -\Delta \vec{p}_t = -\left(\vec{p}_{2t} - \vec{p}_{1T}\right)$$

$$= -\left[18.8 \text{ kg} \cdot \text{m/s} (30.0^\circ \text{ S of E}) - 0\right]$$

$$= 18.8 \text{ kg} \cdot \text{m/s} [30.0^\circ \text{ N of W}]$$



- e) The system of the two rocks has a centre of mass midway between them. As the rocks move, so does this centre of mass. The total momentum of the system can be thought of as the momentum of the centre of mass. The relationship for momentum can be expressed as

$$\vec{P}_{\text{total}} = m_{\text{total}} \vec{v}_{\text{centre of mass}}$$
$$27.3 \text{ kg} \cdot \text{m/s} [\text{E}] = (18.8 \text{ kg} + 18.8 \text{ kg}) \left( \vec{v}_{\text{centre of mass}} \right)$$
$$\vec{v}_{\text{centre of mass}} = 0.726 \text{ m/s} [\text{E}]$$

- f) Again, the impulse applied to the shooter rock causes a change in its momentum. We have already calculated the change in momentum for the shooter, so impulse equals  $18.8 \text{ N} \cdot \text{s}$  [30.0 N of E].





## Appendix 1.7: Projectiles

### Illustrative Examples

1. An object is launched horizontally off a 100 m cliff at a speed of 10 m/s. Determine the range of the projectile from the base of the cliff.

*Solution:*

Determine the time in air using  $d_y = v_y t + \frac{1}{2} g t^2$  where

$$d = -100 \text{ m}$$

$$v_y = 0 \text{ m/s, and}$$

$$g = -9.81 \text{ m/s}^2 \text{ (Time} = 4.52 \text{ s)}$$

Determine the range using  $d_x = v_x t$ . (Range = 42.5 m).

2. An object is launched at  $30^\circ$  above the horizontal with a speed of 15 m/s. Determine:
  - a) total time in air
  - b) maximum height
  - c) range

*Solution:*

Calculate the components  $v_{1y}$  (+7.5 m/s) and  $v_{1x}$  (+13.0). Determine the time in air using  $d_y = v_{1y} t + \frac{1}{2} a t^2$  where  $d = 0$  m ( $t = 1.53$  s). Determine the maximum height using  $d_y = v_{\text{avg}} t$  where  $t$  is half the total time ( $d_y = 2.87$  m). Determine the range using  $d_x = v_x t$  where  $t$  is the total time in the air ( $d_x = 19.9$  m).

**Note:** The above solution is only a suggested method to resolve the problem. Various textbooks may have alternative approaches.



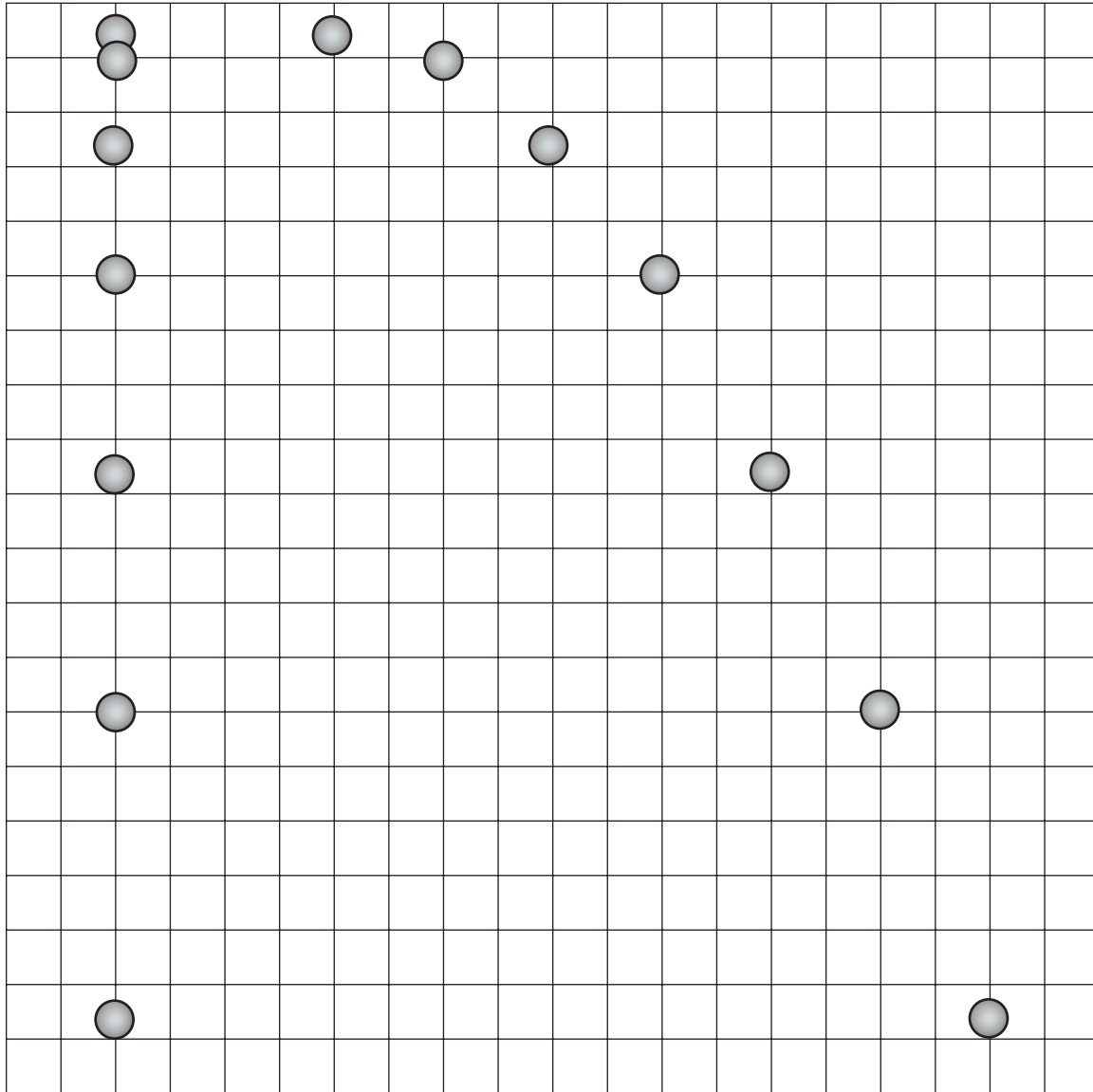

## Appendix 1.8: Force-Work Relationships

### Illustrative Examples

- A 20.0 kg crate is pulled 50.0 m along a horizontal floor by a constant force exerted by a person,  $F = 1.00 \times 10^2$  N, which acts at a  $20.0^\circ$  angle to the horizontal. The floor is rough and exerts a friction force  $F_f = 15.0$  N. Determine the work done by each force acting on the crate, and the net work done on the crate.

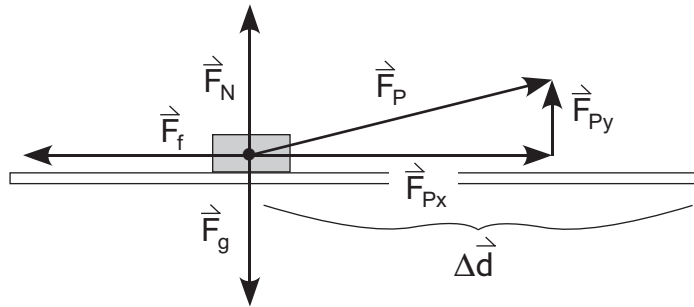

In this case, the force of gravity and the normal force do no work since the crate is not displaced in their direction.

*Solution A:*

Add up the work done by each object.

Work done by the Person ( $W_p$ )

$$\text{Work} = F_p \Delta d \cos \theta$$

$$W_p = (1.00 \times 10^2 \text{ N})(50.0 \text{ m})(\cos 20.0^\circ) = +4.70 \times 10^3 \text{ J}$$

Work done by Friction ( $W_f$ )

$$\text{Work} = F_f \Delta d \cos \theta$$

$$W_f = (15.0 \text{ N})(50.0 \text{ m})(\cos 180.0^\circ) = -7.50 \times 10^2 \text{ J}$$

(The negative sign means work is done, which opposes the motion, and energy is lost by the crate.)

Net Work Done:

Since work is a scalar, we can take the algebraic sum of the work done by each force.

$$W_{\text{net}} = W_p + W_f = (+4.70 \times 10^3 \text{ J}) + (-7.50 \times 10^2 \text{ J}) = +3950 \text{ J}$$



*Solution B:*

Find the net force on the object in the direction of motion and multiply by the displacement.

$$W_{\text{net}} = F_{\text{net}} \Delta d \cos \theta$$

$$\text{where } F_{\text{net}} = F_p \cos \theta + F_f = 100 \cos 20 + -15 = 79 \text{ N}$$

$$W_{\text{net}} = (50 \text{ m}) 79$$

$$W_{\text{net}} = +3950 \text{ J}$$



## Appendix 1.9: Centrifuge Demonstration

This demonstration consists of two water-filled bottles containing ping pong balls and golf balls sitting on a rotating platform. The ping pong balls are hollow and float, and the golf balls are solid and sink. Each ball is attached by a thread to either the top or the bottom of the jar. When the apparatus is rotated, the ping pong balls tilt in toward the centre of rotation and the golf balls tilt outwards away from the centre of rotation.



## APPENDIX 2: FIELDS

### Appendix 2.1: Charges Moving Between or Through Parallel Plates

#### Illustrative Example 1

Two plates are 0.050 m apart and have an electric field of 0.025 N/C with the upper plate being positive. If an electron is placed on the negative plate between the two plates, what is the final velocity of the charge as it hits the positive plate?

*Solution:*

Find the force acting on the charge.

$$F_E = qE = (-1.6 \times 10^{-19} \text{ C})(0.025 \text{ N/C}) = 4 \times 10^{-21} \text{ N}$$

$F_{\text{net}} = F_E$ , therefore,  $ma = qE$  or

$$a = \frac{qE}{m} = \frac{4.0 \times 10^{-21} \text{ N}}{9.11 \times 10^{-31} \text{ kg}} = 4.4 \times 10^9 \text{ m/s}^2$$

Then the final velocity is:

$$\begin{aligned} v_f^2 &= v_i^2 + 2a\Delta d \\ &= 0 + 2(4.4 \times 10^9 \text{ m/s}^2)(0.050 \text{ m}) \\ &= 4.4 \times 10^8 \text{ m}^2/\text{s}^2 \\ \therefore v_f &= 2.1 \times 10^4 \text{ m/s} \end{aligned}$$



### Illustrative Example 2

An alpha particle (mass =  $6.65 \times 10^{-27}$  kg, charge = +2) with a velocity of  $1.2 \times 10^6$  m/s enters the region between horizontal parallel plates that are 0.040 m apart and 0.10 m long. The potential difference between the two plates is 4500 V with the upper plate positive. When the alpha particle exits the plates, how far has it dropped and what is its new velocity?

First, list and organize the kinematic information (answers in parentheses are solved below):

$$\begin{array}{ll}
 v_{1x} = 1.2 \times 10^6 \text{ m/s} & v_{1y} = 0 \text{ m/s} \\
 v_{2x} = 1.2 \times 10^6 \text{ m/s} & v_{2y} = \\
 a_x = 0 & a_y = (-5.41 \times 10^{12} \text{ m/s}^2) \\
 d_x = 0.10 \text{ m} & d_y = (1.88 \times 10^{-2} \text{ m}) \\
 t = (8.33 \times 10^{-8} \text{ s}) & t = (8.33 \times 10^{-8} \text{ s})
 \end{array}$$

$$t = \frac{d_x}{v_x} = \frac{0.10 \text{ m}}{1.2 \times 10^6 \text{ m/s}} = 8.33 \times 10^{-8} \text{ s}$$

$$a = \frac{F_e}{m} = \frac{qE}{m} = \frac{q \left( \frac{V}{\Delta d_y} \right)}{m} = \frac{qV}{m\Delta d_y} = \frac{(2 \times 1.6 \times 10^{-19} \text{ C})(4500 \text{ V})}{(6.65 \times 10^{-27} \text{ kg})(0.040 \text{ m})} = 5.41 \times 10^{12} \text{ m/s}^2$$

$$d_y = v_{1y}t + \frac{1}{2}a_y t^2 = 0 + \frac{1}{2}at^2 = \frac{1}{2}(5.41 \times 10^{12} \text{ m/s}^2)(8.33 \times 10^{-8} \text{ s})^2 = 1.88 \times 10^{-2} \text{ m}$$

$$v_{2y} = v_{1y} + a\Delta t = 0 + (5.41 \times 10^{12} \text{ m/s}^2)(8.33 \times 10^{-8} \text{ s}) = 4.51 \times 10^5 \text{ m/s}$$



## Appendix 2.2: Space Exploration Issues

### Identify and Discuss Issues Pertaining to Space Exploration

#### Historical Perspective

- <<http://www.solarviews.com/eng/history.htm>>
- <[http://calspace.ucsd.edu/spacegrant/california/new/kids/history\\_space.html](http://calspace.ucsd.edu/spacegrant/california/new/kids/history_space.html)>

#### Issues

##### 1. Technological advancement

This relates to the drive to spread genetic material and ensure the success of not just the species, but of one type of genetic material. The wider the distribution of a species, the better the chance of survival. Perhaps the best reason for exploring space is the built-in genetic predisposition to expand into all possible niches.

<[http://adc.gsfc.nasa.gov/adc/education/space\\_ex/essay1.html](http://adc.gsfc.nasa.gov/adc/education/space_ex/essay1.html)>

##### 2. Promotion of global co-operation

##### 3. Social and economic benefits

- Exploration also allows resources to be located. Resources translate into power and success at survival. Whether the success be financial, political, or genetic, additional resources are always a boon when used wisely.

<[http://adc.gsfc.nasa.gov/adc/education/space\\_ex/essay1.html](http://adc.gsfc.nasa.gov/adc/education/space_ex/essay1.html)>

- <<http://www.maxwell.af.mil/au/aul/school/pmcs/nq13econ.htm>>

##### 4. Allocation of resources shifted away from other pursuits

- <<http://www.sepp.org/space/mars.html>>

##### 5. Possibility of disaster

- <<http://www.sepp.org/space/riskmross.html>>
- <<http://www.house.gov/beauprez/issues/nasa.htm>>
- <[http://news.bbc.co.uk/1/hi/talking\\_point/2718035.stm](http://news.bbc.co.uk/1/hi/talking_point/2718035.stm)>





## NOTES



## APPENDIX 3: ELECTRICITY

### Appendix 3.1: The Historical Development of Ohm's Law

#### Tapping into Prior Knowledge

What are some characteristics of this new phenomena we call electricity?

- The forces of attraction and repulsion depend on separation.
- Energy is dissipated as heat and shock.
- It can be conducted from one place to another.
- In Senior 1 Science, a particle model electricity was extended to a qualitative study of electric circuits. More particles, more current; more current, more brightness in the bulbs.

Some points to consider:

1. Now we want to develop a quantitative model of current electricity.
2. Note, at this time, Ohm had no model of electricity in mind. His interest was in formulating a mathematical law. This is a form of induction.
3. Ohm knew that electricity could be conducted from one place to another through a wire (see Gray's experiment below).
4. Ohm did not have electrical meters as we know them today. What did he do?

#### Demonstration: Gray's Experiment

Figure 1 is Gray's initial experiment. He used thread, feathers, and an electroscope. Figure 2 is a classroom demonstration using a tinfoil bit and ordinary copper wire. You can demonstrate that electricity can be conducted over large distances through the wire.

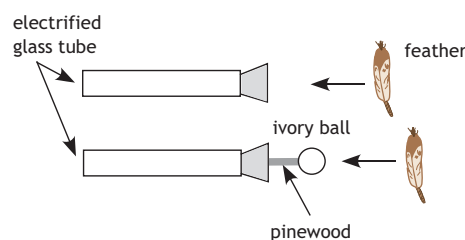

Figure 1

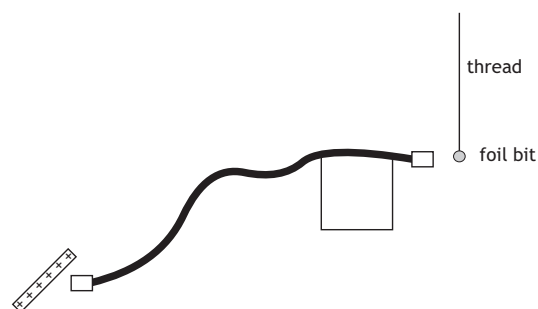

Figure 2



## Henry Cavendish and the First Electric Meter

In 1799, Cavendish designed an investigation to qualitatively describe the conductivity of different metals. He used a very simple technique by discharging an electrical apparatus through a wire to his own body. Cavendish rotated a frictional generator with a fixed number of turns to produce the same amount of charge for each trial, and he was able to correctly order the conductivity of the metals by the intensity of shock he received from the generator. Cavendish, whose results were never published in his time, was qualitatively comparing the resistance of different materials to the effects of current.

This type of qualitative analysis was an entertaining pastime in some 18th-century kitchens and parlours—small boys and women have been depicted in paintings passing shocks from electrostatic machines through the familiar “human chain” of resistance. In addition to the obvious risk, resistance, from the earliest times, was demonstrated to be dependent on the length of the conductor. In addition, the spark gap and physiological shock could be related to the intensity of the charge distribution. For example, consider a sphere charged by a fixed number of turns. When discharged, it could produce a spark across a measurable gap. If we use a smaller sphere charged with the same number of turns, we observe that the spark jumps a larger gap. In other words, the same quantity of charge in a smaller volume has a greater “intensity.”

This intensity, or “tension,” could be more accurately measured by an electroscope and, after Volta’s invention of the electric pile in 1800, attempts were made to relate static electricity with other types of electricity. Volta’s battery marks a significant conceptual change in our understanding of the electrical phenomenon. The battery remains inactive until an external conductor provides a path through which the electricity is conveyed. Thus, it became imperative to reveal the characteristics and influence of the external conductor. However, at this time, no instrument (other than human sensation) existed that could measure or ascertain the phenomena associated with the conductor.

Fortunately, Cavendish’s role as a human meter was no longer necessary by 1820 with Oersted’s discovery of the deflection of a compass needle by an electric current. Shortly afterwards, Schweigger used a coil to pass a current repeatedly over a compass to fabricate a more sensitive instrument to detect and compare the electromagnetic effects of various currents.

## The Tangent Galvanometer



The first reference to a tangent galvanometer appeared in an 1837 paper by Claude Servais Mathias Pouillet (1790–1868). Pouillet used the tangent galvanometer to investigate Ohm’s Law and later, James Joule, in 1841, immersed different lengths of wire into cylinders of water to investigate the relationship between the rate of heat dissipation and current.

The tangent galvanometer was modified by Hermann von Helmholtz (1821–94) in 1849. He suggested that two, identical, current-carrying coils be placed parallel to each other to form the arrangement now known as Helmholtz coils. In this arrangement the magnetic field is essentially uniform. The instrument at the left is in the collection at Wesleyan University.



To measure current, Joule used a tangent galvanometer, which was aligned with the North-South meridian such that the magnetic field of the coil was perpendicular to the magnetic field of the Earth. The deflection of the compass needle is the vector sum of the magnetic effects of the Earth and the field of the loop. Therefore,

$$\tan \theta = \frac{B_{loop}}{B_{earth}}$$

Since  $B_{earth}$  is constant, it follows that  $\tan \theta \propto B_{loop}$ . By increasing the number of loops, and therefore the current past any given point, we can also establish that  $I \propto B_{loop}$ , and therefore  $\tan \theta \propto I$  and  $\tan \theta$  can be used as a measure of current. Joule's tangent galvanometer proved to be a reliable measure of current, which we can still use today. The use of a tangent galvanometer has the additional advantage of providing an evidential base for the modern galvanometer and ammeter.

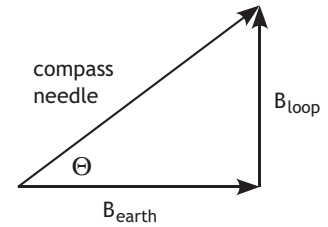

### Ohm's Experiment

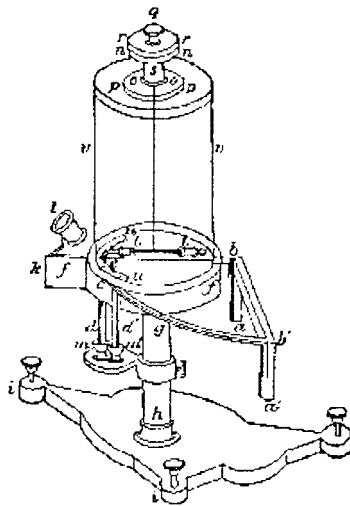

A reliable tangent galvanometer can easily be constructed by looping a wire around a platform that supports a compass. Different lengths of resistance wire are connected to the tangent galvanometer in a manner similar to Ohm's actual experiments. For convenience, a nichrome resistance wire can be laid across a meter stick, and using a sliding contact, different lengths of wire can easily be obtained. The magnetic field of the loop is aligned in a North-South direction and the tangents of the deflections of the compass needle (current) are graphed versus the resistance (measured by length) to confirm that the current is inversely proportional to the resistance of the circuit.

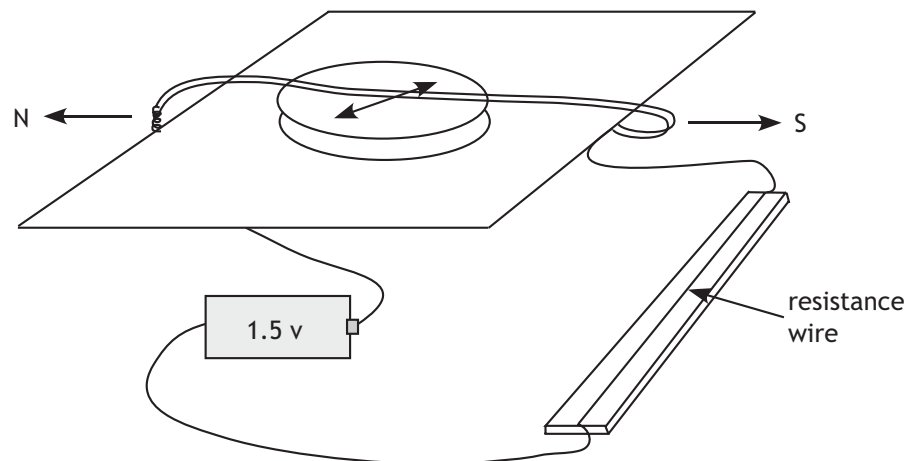

## Ohm's Experiment

1. Set up the apparatus as shown. Leave one connection at the battery open (or use a switch to turn the current on and off).
2. Prepare several lengths of resistance wire or use a sliding connection to a resistance wire 1 metre long.
3. Beginning with the longest wire first, connect the circuit and measure the deflection of the compass. Be sure your compass needle moves freely (you may lightly tap the platform to check). Note: disconnect the battery as soon as you record the deflection of the compass needle. Leaving the battery connected could heat the wires and change the resistance.

### Data Table

<b>Resistance Length (m)</b>	0.20	0.40	0.60	0.80	1.00
$\theta$ (degrees)					
$\tan \theta$					

4. Graph Current ( $\tan^2$ ) versus Resistance (length of wire).
5. "Straighten" the curve to determine the relationship between current and resistance.
6. What does the constant represent?
7. Repeat the experiment using an ammeter instead of a tangent galvanometer.

## Conclusion

We have demonstrated that

$$I = \frac{a}{R},$$

where  $I$  is current,  $R$  is the total resistance, and  $a$  is a constant.  $R_T = b + x$ , where  $x$  is the resistance wire and  $b$  is the fixed resistance of the circuit. Can you calculate  $b$  in terms of length? Proportion of total resistance?

Ohm repeated the experiment with a different temperature difference and found a different value for  $a$ . The constant  $a$  must be associated with the battery, but what it meant was left for Kirchoff to determine 25 years later. Kirchoff synthesized Coulomb's law, electric potential energy between two charges, Joule's experiment, and Ohm's experiments into a coherent mathematical theory.



## Appendix 3.2: Power, Resistance, and Current

### Introduction

James Prescott Joule first explored the relationships among power, resistance, and electric current in 1841. We shall attempt to duplicate his efforts with this experiment.

As current passes through a coil of wire, it generates heat. The heat is transferred to water in a simple calorimeter (Styrofoam™ cup). You will calculate the heat gained by the water and the power of the heating coil. You may then determine the relationships graphically.

### Part 1: Power and Resistance

#### Apparatus

- 6V or 12V battery
- nichrome heating coils
- Styrofoam™ cups and lids
- thermometers
- watch
- plastic straws
- 100 mL graduate
- patch cords
- ohmmeter

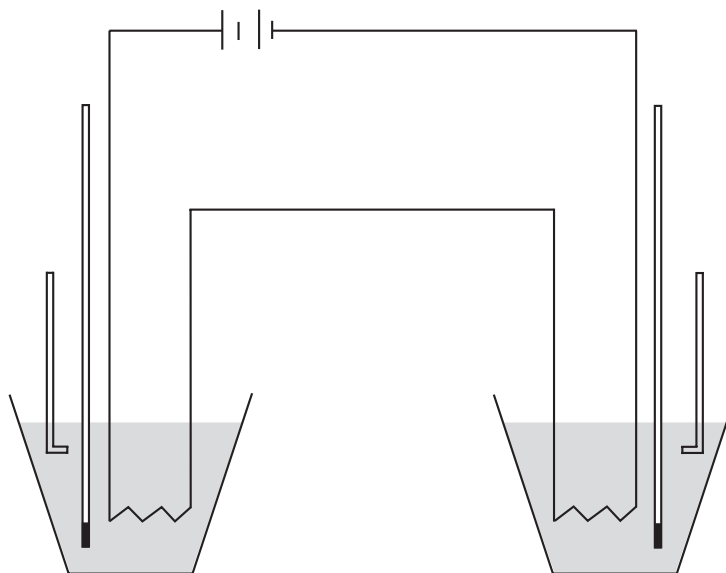

**Procedure**

1. Prior to the experiment, allow sufficient water to reach room temperature.
2. Pour exactly 100 mL of water into each Styrofoam™ cup. This will provide 100 g of water to be heated.
3. Measure the resistance of each coil. Record in the data table.
4. Assemble the battery and heating coils in series to provide an identical current through each coil. Leave one connection open until you are ready to begin the experiment.
5. Record the initial temperature, to the nearest 0.1° C, for each water sample. Record in the table.
6. Complete the circuit to allow current to pass through the coils. At one-minute intervals, gently stir the water samples with their straws. Observe the temperatures.
7. After sufficient heating has occurred, record the time elapsed and the final temperatures of each sample.
8. Calculate the heat developed from:  
 Heat = mass (g) x specific heat x temperature difference (°C)  
 $H = mc\Delta T$   
 Water has a specific heat of 4.2 J/g°C  
 Determine power:  
 Power = Energy (heat)/time  
 (Time must be measured in seconds.)
9. Plot a graph of power vs. resistance and graphically determine the relationship.

Resistance (Ω)	Mass of Water (g)	Time (s)	Temperature (°C)			Heat (J)	Power (W)
			T <sub>i</sub>	T <sub>f</sub>	ΔT		



## Part 2: Power and Current

### Apparatus

- 6V battery
- heating coils of identical resistance
- resistance coil
- patch cords
- ammeter
- thermometer
- watch (or digital thermometer and LabPro)
- 100 mL graduated cylinder
- Styrofoam™ cups and lids

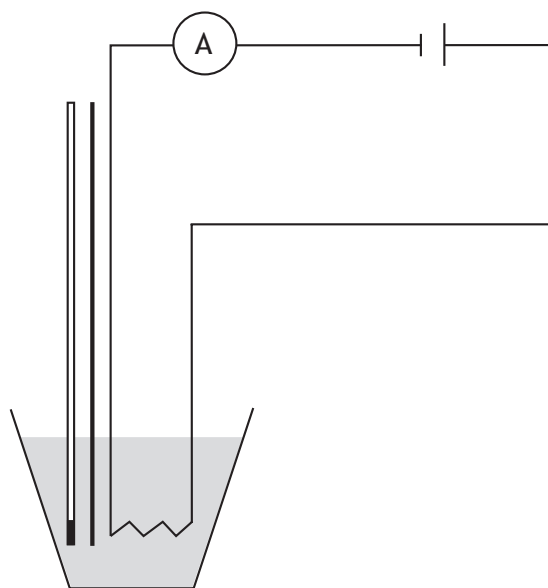

### Procedure

1. Prior to the experiment, allow about one litre of water to reach room temperature.
2. Pour exactly 100 mL of water into each Styrofoam™ cup. Place the heating coil and thermometer arrangement into the water and obtain an initial temperature reading to the nearest 0.1° C.
3. Prepare the circuit to deliver current to the heating coil and resistance coil in parallel. Be sure to connect the ammeter in series with the heating coil only.
4. Connect the D cell and begin recording time, current, and temperature readings every minute. Gently stir the water for a few seconds prior to reading the thermometer. Collect data until a temperature rise of at least a few degrees is noticed. Record in the data table.





5. Use a fresh sample of water and another heating coil. Adjust the resistance coil to a different value so a different current will pass through the heating coil. Repeat Step 4 above. Perform several different trials, using very different currents in identical heating coils.
6. Calculate the heat developed from:
 

Heat = mass (g) x specific x temperature heat difference (°C)

$H = mc\Delta T$

Water has a specific heat of 4.2 J/g °C
7. Determine power:
 

Power = Energy (heat)/time (Time must be measured in seconds.)
8. Plot a graph of power vs current. Perform graphical manipulations as required to determine the relationship between power and current.

**Data Table: Power and Current**

Current (A)	Mass (g)	Temperature (°C)			Heat (J)	Time (s)	Power (W)
		T <sub>i</sub>	T <sub>f</sub>	ΔT			



### Appendix 3.3: Kirchoff's Contribution

By experimentation Ohm found that in an electric circuit

$$I = \frac{a}{R},$$

where  $a$  is a constant of proportionality. Later, Joule demonstrated that  $P = I^2R$ . Both experiments are examples of scientific laws developed inductively from observations of the behaviour of electric circuits. Additionally, both experiments are concerned with charges in motion. Kirchoff started with the energy considerations of static charges and showed the following.

#### Electric Potential

Electric potential is the electric potential energy *per unit charge*.

$$V = \frac{E_e}{Q}$$

Therefore,  $E_e = QV$

We also know that the work done moving a charge in a field is the change in energy.

$$W = \Delta E_e$$

Therefore, the change in energy between points  $a$  and  $b$

$$E_b - E_a = QV_b - QV_a$$

or

$$\Delta E_e = QV_b - QV_a$$

$$\Delta E_e = Q(V_b - V_a)$$

$$\Delta E_e = Q\Delta V$$

where  $\Delta V$  is called **Electric Potential Difference (voltage)**. Since we only deal with changes in energy, this is the most important term. Now, if we divide both sides of the equation by time

$$\frac{\Delta E_e}{t} = \frac{Q}{t} \Delta V$$

$$P = I\Delta V$$

That is, the power delivered (dissipated) in a circuit is the current times the voltage. (In terms of charged particles, why does this make sense?) Recall Joule,

$$P = I^2R$$

Therefore,  $I^2R = I\Delta V$ , and

$$I = \frac{\Delta V}{R}$$



Thus, Kirchoff demonstrated that if the constant in Ohm's Law was voltage, that everything we knew about in terms of static and dynamic electricity fit together in a coherent theoretical and practical system (in other words, it is a good theory).

**Determine the resistance, current, voltage, and power for series, parallel, and combined networks.**

Circuit analysis would begin with simple series and simple parallel circuits. The following is an example of the analysis of a combined network or complex circuit.

In the circuit below, determine the current, the voltage drop, and the power consumed by each resistor.

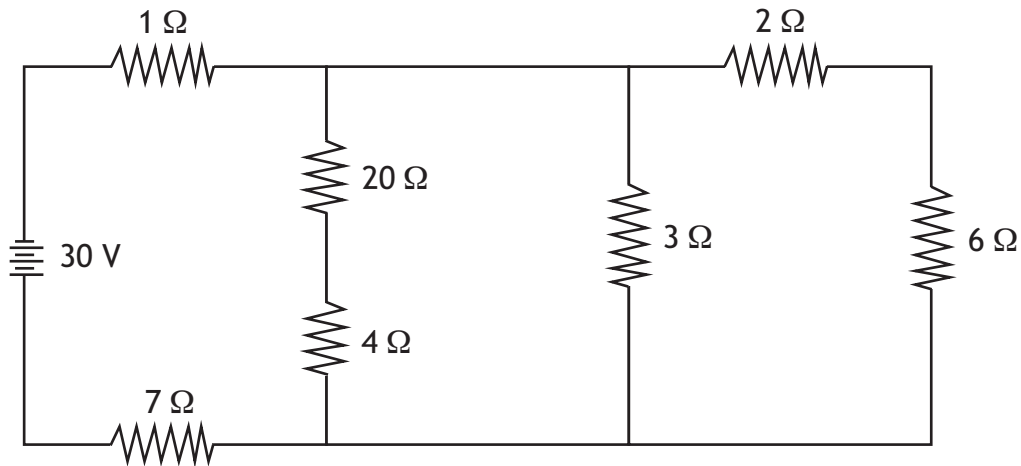

The circuit is neither a simple series nor a simple parallel connection of resistors. It contains both groupings, so it is an example of a complex circuit.

Generally, it is necessary to determine the total or equivalent resistance of the circuit before other electrical quantities can be calculated. In such a complex circuit, it is necessary to identify the resistors that are in series with each other and those that are in parallel with each other. These groups of resistors can be added together to reduce the number of resistors in the circuit. This process continues until the circuit is reduced to a single resistor.

Usually, begin by looking at resistors furthest from the source. In this case, the 2 Ω and 6 Ω resistor are in series and may be combined to a single value of 8 Ω. At the same time, 20 Ω and 4 Ω may be combined to give 24 Ω.



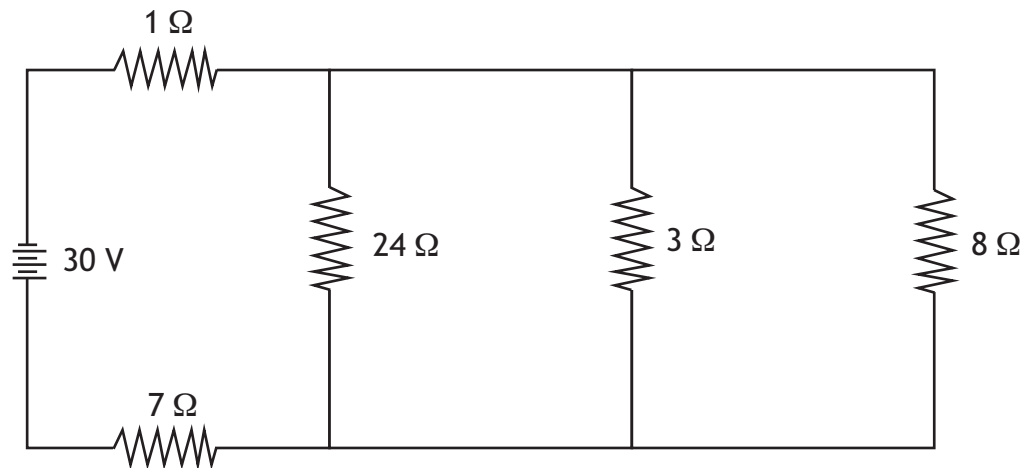
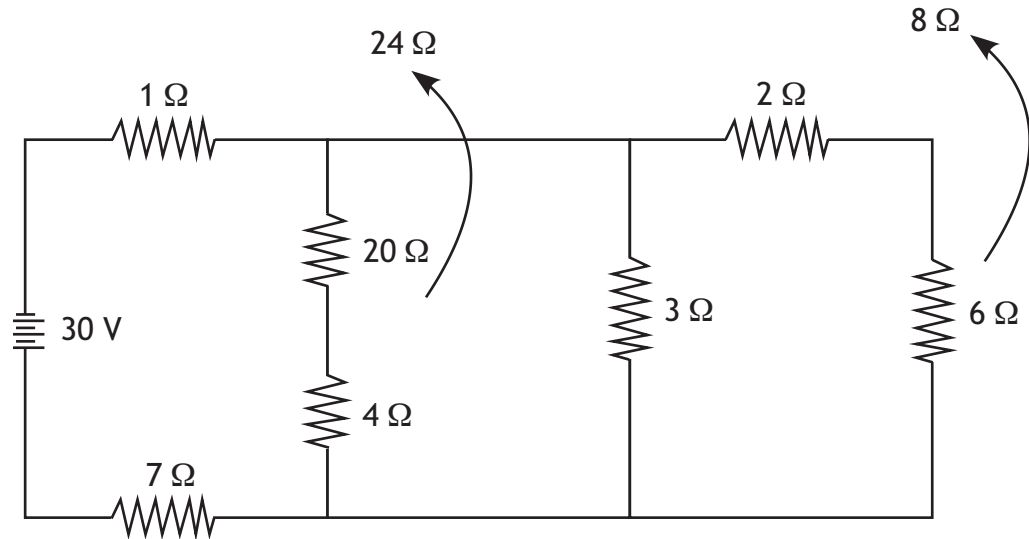

This results in three resistors of  $24\ \Omega$ ,  $3\ \Omega$ , and  $8\ \Omega$  in parallel. Combining these in parallel:

$$\frac{1}{R_T} = \frac{1}{R_1} + \frac{1}{R_2} + \frac{1}{R_3} = \frac{1}{24} + \frac{1}{3} + \frac{1}{8} = \frac{1}{24} + \frac{8}{24} + \frac{3}{24} = \frac{12}{24}$$

$$\therefore R_T = \frac{24}{12} = 2\ \Omega$$



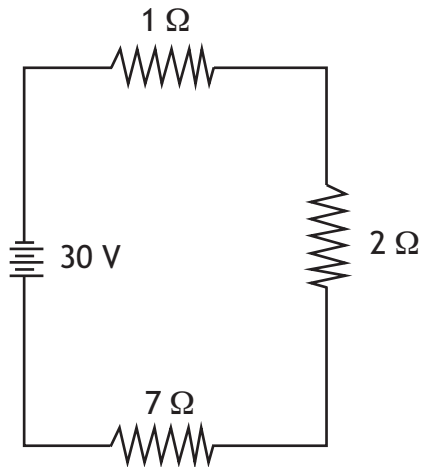
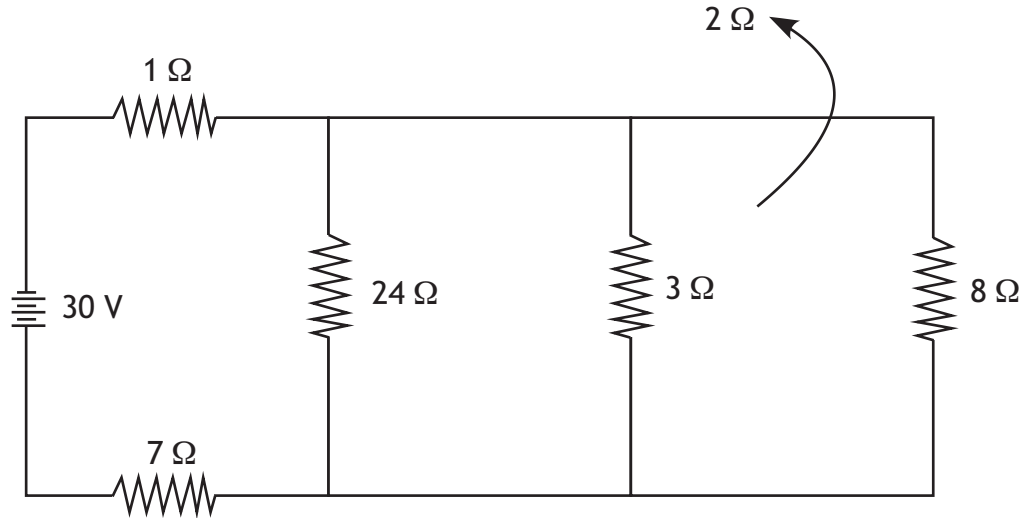

The circuit now consists of three resistors in series. The total resistance for the entire circuit is  $R_T = 1 + 2 + 7 = 10 \Omega$ .

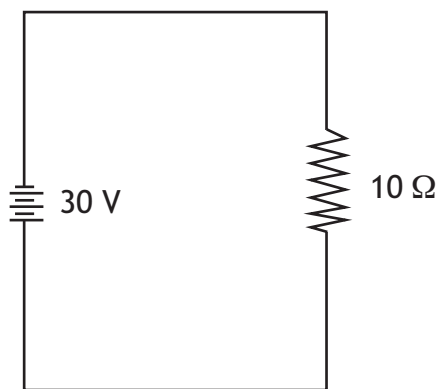

This is often called the equivalent resistance, and this simple circuit, consisting of a single source and a single resistor, is known as the equivalent circuit.

The equivalent resistance of  $10 \Omega$  draws the same amount of current from the power supply as the original complex network.



To complete the analysis, we work backwards to the original circuit, applying Kirchoff's laws:

- Kirchoff's Current Law: The sum of currents entering a junction must equal the sum of currents leaving that junction.
- Kirchoff's Voltage Law: The sum of potential drops around a circuit must equal the sum of potential rises around the circuit.

Once the total resistance is calculated, find the total current that leaves and returns to the

$$\text{source } I = \frac{V}{R} = \frac{30 \text{ V}}{10 \Omega}.$$

This is called the main line of the circuit since it has the total current in it. It is helpful to draw this in the circuit.

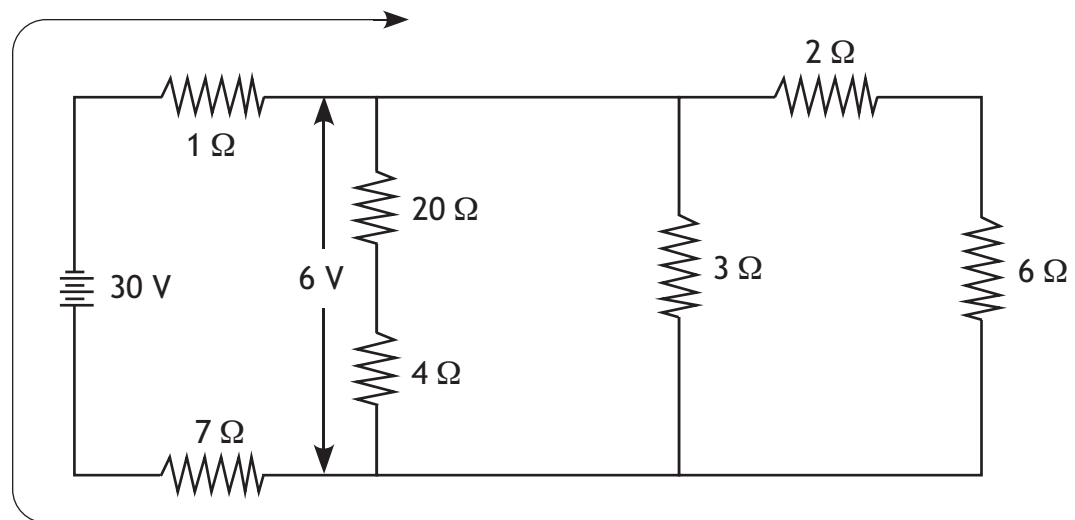

This total current passes through the  $1 \Omega$  and  $7 \Omega$  resistors. This results in a voltage drop across each of them.

$$V_{\text{drop}} = IR = (3 \text{ A})(1 \Omega) = 3 \text{ V and}$$

$$V_{\text{drop}} = (3 \text{ A})(7 \Omega) = 21 \text{ V}$$

The voltage drop left for the remainder of the circuit is  $30 \text{ V} - 24 \text{ V} = 6 \text{ V}$ .

This  $6 \text{ V}$  appears across the three parallel branches so the current in each branch can be determined. Since voltages across parallel resistances are the same:

$$I = \frac{V}{R} = \frac{6 \text{ V}}{24 \Omega} = 0.25 \text{ A}$$

$$I = \frac{V}{R} = \frac{6 \text{ V}}{3 \Omega} = 2 \text{ A}$$

$$I = \frac{V}{R} = \frac{6 \text{ V}}{8 \Omega} = 0.75 \text{ A}$$



The voltage drop across the 20  $\Omega$  and 4  $\Omega$  resistors may be calculated.

$$V_{\text{drop}} = IR = (0.25 \text{ A})(20 \Omega) = 5 \text{ V} \text{ across the } 20 \Omega \text{ resistor}$$

The voltage drop across the 4  $\Omega$  resistor can be found the same way or by using Kirchoff's Voltage Law. Since 6 V appears across both resistors and the 20  $\Omega$  resistor has a drop of 5 V across it, then the 4  $\Omega$  resistor has a drop of  $6 \text{ V} - 5 \text{ V} = 1 \text{ V}$ .

A similar method can be used to find the voltage drops across the 2  $\Omega$  and 6  $\Omega$  resistors. For the 2  $\Omega$  resistor:  $V_{\text{drop}} = IR = (0.75 \text{ A})(2 \Omega) = 1.5 \text{ V}$ . The voltage drop across the 6  $\Omega$  resistor is  $6 \text{ V} - 1.5 \text{ V} = 4.5 \text{ V}$ .

Use Watt's Law or its two variations to find the power consumed by each resistor:

For the 1  $\Omega$  and 7  $\Omega$  series resistors in the main line of the circuit:

$$P = IV = (3 \text{ A})(1 \Omega) = 3 \text{ W}$$

$$P = IV = (3 \text{ A})(7 \Omega) = 21 \text{ W}$$

For the 20  $\Omega$  and 4  $\Omega$  resistors that are in series with each other, but part of the parallel group:

$$P = I^2R = (0.25 \text{ A})^2(20 \Omega) = 1.25 \text{ W}$$

$$P = I^2R = (0.25 \text{ A})^2 (4 \Omega) = 0.25 \text{ W}$$

The 3  $\Omega$  resistor has a voltage drop of 6 V across it.

$$P = \frac{V^2}{R} = \frac{(6 \text{ V})^2}{3 \Omega} = 12 \text{ W}$$

The 2  $\Omega$  and 6  $\Omega$  resistors are in series and have the same current through them.

$$P = I^2R = (0.75 \text{ A})^2(2 \Omega) = 1.125 \text{ W}$$

$$P = I^2R = (0.75 \text{ A})^2 (6 \Omega) = 3.375 \text{ W}$$

Note that these values may be obtained in different ways by using different variations of Watt's Law, Ohm's Law, or Kirchoff's Laws. This provides the students with excellent problem-solving practice.

Also note that conventions regarding significant figures have not been adhered to in this example. This allows one to verify results obtained by different methods of calculation.



### Appendix 3.4: Electromagnetic Induction

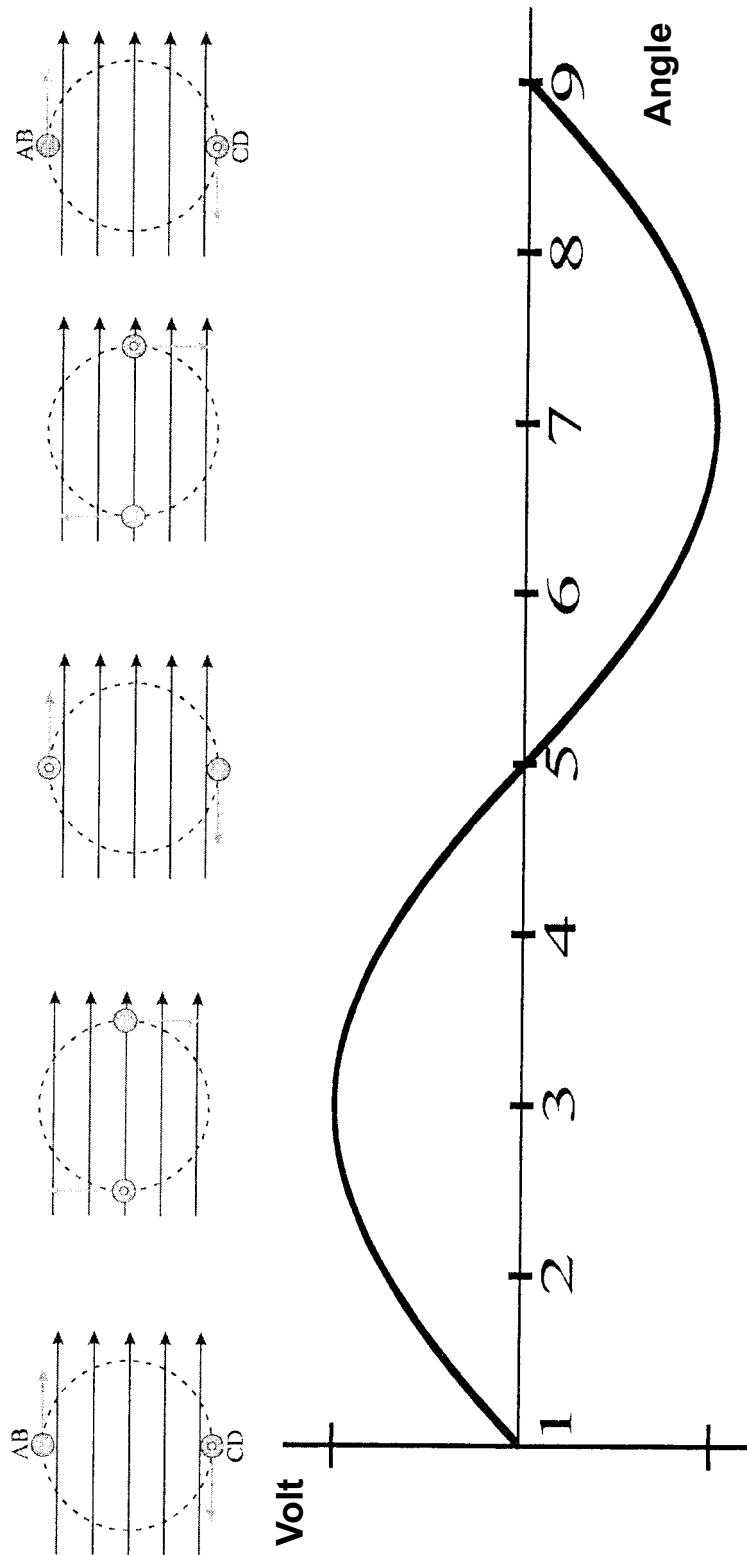



## Appendix 3.5: Faraday's Law

$$V = \frac{N\Delta\Phi}{\Delta t}$$

### Illustrative Example 1

The magnetic flux through a flat coil of 20 turns changes by  $9 \times 10^{-4}$  webers in 3 milliseconds. Determine the magnitude of the voltage induced in the coil.

$$V = \frac{N\Delta\Phi}{\Delta t} = \frac{(20)(9 \times 10^{-4} \text{ Wb})}{3 \times 10^{-3} \text{ s}} = 6 \text{ V}$$

### Illustrative Example 2

A coil of 120 turns and radius 12 cm is rotating in a 0.055 T magnetic field at 3200 revolutions per minute. What is the magnitude of the voltage produced during the quarter turn of the coil from B being parallel to the normal of the coil to B being perpendicular to the normal of the coil?

For B being parallel to the normal, then  $\sin \theta = 1$  and  $B_{\perp} = 0.055 \text{ T}$ . For B being perpendicular to the normal,  $\sin \theta = 0$  and  $B_{\perp} = 0$ . So, for this quarter turn,  $|\Delta B_{\perp}| = 0.055 \text{ T}$ .

The area of the loop is:  $A = \pi r^2 = \pi(0.12)^2 = 0.0452 \text{ m}^2$

The time for a quarter revolution is:  $\frac{1 \text{ min}}{3200 \text{ rev}} \times \frac{60 \text{ s}}{1 \text{ min}} \times 0.25 \text{ rev} = 0.00469 \text{ s}$

$$\text{Finally, } V = \frac{N\Delta\Phi}{\Delta t} = \frac{N(\Delta B)A}{\Delta t} = \frac{(120)(0.055 \text{ T})(0.0452 \text{ m}^2)}{0.00469 \text{ s}} = 64 \text{ V}$$



**Illustrative Example 3**

1. A bar magnet is thrust into a solenoid as shown below. Find the direction of current between points A and B.

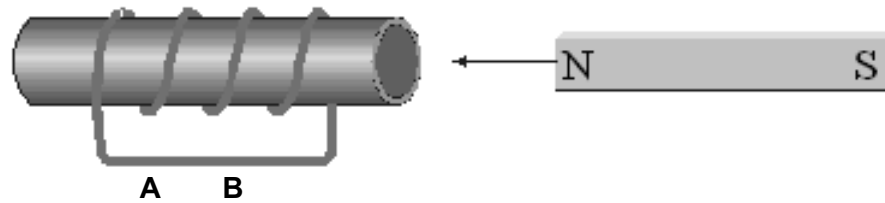

From Lenz's Law, the induced current in the solenoid establishes a magnetic field that opposes the original changing flux. Therefore, a North pole is induced at the right side of the solenoid and South will be on the left side. Using the right-hand rule for coils, extend the thumb of the right hand in the direction of the magnetic field (remember that inside a solenoid, the magnetic field points from South to North). Point the thumb right and your fingers will curl out of the page on top of the coil and into the page on the bottom of the coil. Therefore, the current will flow from A to B.

2. The switch in solenoid circuit 1 is closed. Find the direction of current between A and B in solenoid 2.

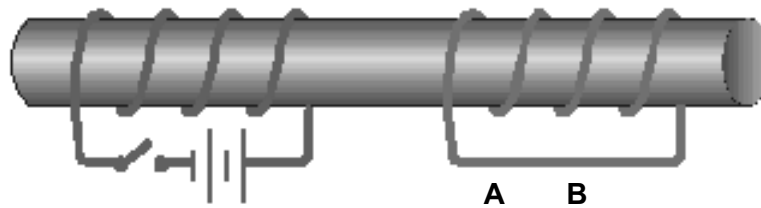

When the switch is closed, the current in solenoid 1 causes a magnetic field to be created with force lines pointing to the right (use the right-hand rule). This field (momentarily changing from 0 to B) induces a current in solenoid 2 such that the magnetic field created by that current opposes the field in solenoid 1. Therefore, solenoid 2 must have field lines that point to the left and the current in solenoid 2 must flow from B to A.

**Note:** The examples shown use conventional current and right-hand rules. The electron current is actually in the opposite direction.



## NOTES



## APPENDIX 4: MEDICAL PHYSICS

### Appendix 4.1: “Get a Half Life”

Complete the chart below to determine how long it would take for each fraction of the atoms in each element to decay.

Element	Half Life	50% Remains	25% Remains	12.5% Remains
Americium — 241	475 years			
Bismuth — 212	60.5 minutes			
Carbon — 14	5730 years			
Hydrogen — 3	12.26 years			
Iron — 59	45.6 days			
Polonium — 216	0.16 seconds			
Sodium — 24	15 hours			
Uranium — 235	710 000 000 years			
Uranium — 238	4.5 billion years			



**Answer Key: “Get a Half Life”**

<b>Element</b>	<b>Half Life</b>	<b>50% Remains</b>	<b>25% Remains</b>	<b>12.5% Remains</b>
Americium — 241	475 years	475 years	950 years	1425 years
Bismuth — 212	60.5 minutes	60.5 minutes	121 minutes	181.5 minutes
Carbon — 14	5730 years	5730 years	11 460 years	17 190 years
Hydrogen — 3	12.26 years	12.26 years	24.52 years	36.78 years
Iron — 59	45.6 days	45.6 days	91.2 days	136.8 days
Polonium — 216	0.16 seconds	0.16 seconds	0.32 seconds	0.48 seconds
Sodium — 24	15 hours	15 hours	30 hours	45 hours
Uranium — 235	710 000 000 years	710 000 000 years	1 420 000 000 years	2 130 000 000 years
Uranium — 238	4.5 billion years	4.5 billion years	9 billion years	13.5 billion years



## Appendix 4.2: Alpha Decay

The following is an example of the emission of an alpha particle (helium nucleus):

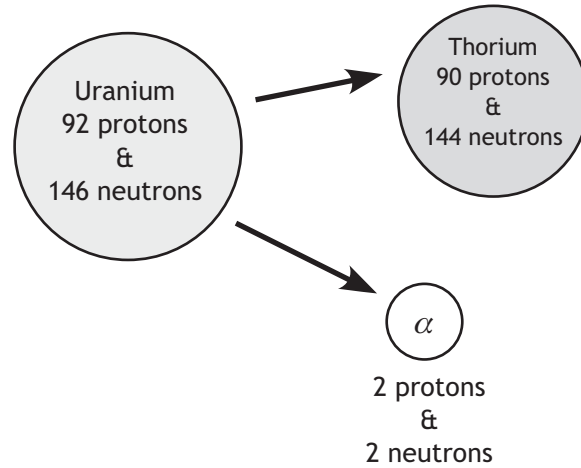
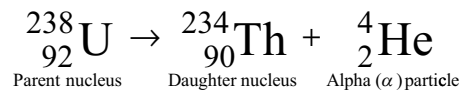

In general, gamma decay can be summed up with the following equation:

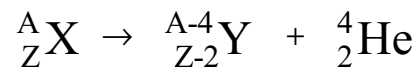

### Appendix 4.3: Beta Decay

The following represents an example of the emission of a beta particle (electron):

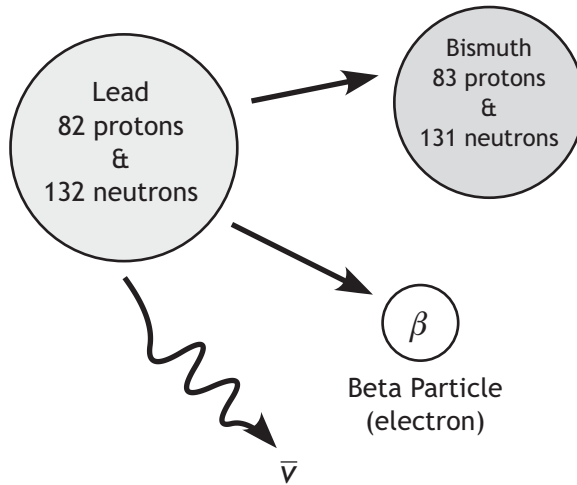
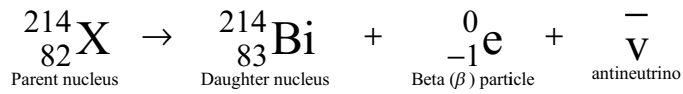

What happens in the nucleus? In general, beta decay can be summed up with the following equation:



## Appendix 4.4: Gamma Radiation

The following is an example of the emission of gamma radiation:

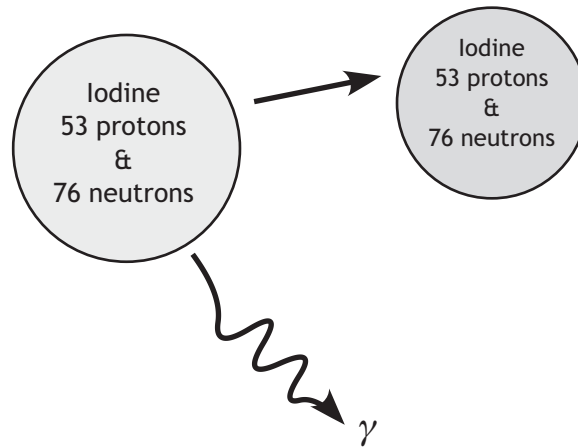
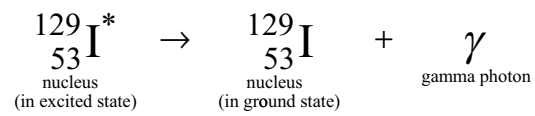

In general, gamma decay can be summed up with the following equation:

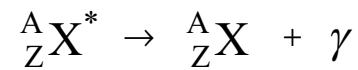



**Appendix 4.5: Radioisotopes and Their Use in the Diagnosis or Treatment of Illness**

<b>Isotope</b>	<b>Half Life</b>	<b>Uses</b>
Arsenic-74	17.9 days	locate brain tumours
Barium-131	12.0 days	detect bone tumours
Carbon-14	5730 days	treat brain tumours
Chromium-51	27.8 days	determine blood volume
Cobalt-60	5.26 years	treat brain tumours
Gold-198	64.8 hours	test kidney activity
Iodine-131	8.05 days	treat thyroid problems; find blood clots
Iron-59	45.6 days	test rate of red blood cell production
Mercury-197	65.0 hours	find brain tumours; test spleen function
Technetium-99	6.0 hours	detect brain tumours; detect blood clots



## APPENDIX 5: DEVELOPING ASSESSMENT RUBRICS IN SCIENCE

---

### The Nature, Purposes, and Sources of Assessment Rubrics for Science

#### What Assessment Rubrics Are

Rubrics are assessment tools that identify criteria by which student processes, performances, or products will be assessed. They also describe the qualities of work at various levels of proficiency for each criterion.

The following types of assessment rubrics may be used in classroom assessment:

- **General rubrics** provide descriptions of proficiency levels that can be applied to a range of student performance processes, performances, or products. Using the same rubric for similar tasks helps teachers manage marking assignments based on student choice, and helps students internalize the common qualities of effective processes, performances, and products.
- **Task-specific rubrics** describe the criteria used in assessing specific forms such as the use of a balance, writing a laboratory report, or calibrating CBL probes. Complex student projects may require a different rubric for each phase (for example, a group inquiry project may require a rubric for collaborative work, information-gathering processes, oral presentations, and written reports).
- **Holistic rubrics** are used to assign a single mark to a process, performance, or product on the basis of its adequacy in meeting identified criteria.
- **Analytic rubrics** are used to assign individual scores to different aspects of a process, performance, or product, based on their specific strengths and weaknesses according to identified criteria. See the Rubric for the Assessment of a Decision-Making Process Activity in Appendix 6.
- **Checklists** are lists of criteria that do not distinguish among levels of performance. They are used to assess the presence or absence of certain behaviours, and are most suitable for assessing processes (for example, “Did the student perform all the necessary steps?”). Because they require “Yes/No” judgements from the assessor, checklists are easy for students to use in peer assessment.
- **Rating scales** ask assessors to rate various elements of a process, performance, or product on a numerical scale. They do not provide complete descriptions of performance at various levels.

## Why Teachers Use Assessment Rubrics

The best assessment tasks ask students to perform the sorts of scientific literacy tasks they will be called upon to perform in real-world situations. They allow students to demonstrate not only the declarative knowledge they have gained, but also the interplay of attitudes, skills, and strategies that constitute their learning. Authentic assessment tasks invite a range of responses and allow students to express their individuality. For all these reasons, assessing scientific literacy is a complex matter.

Assessment rubrics

- help teachers clarify the qualities they are looking for in student work;
- ensure that all students are assessed by the same criteria;
- help teachers communicate the goals of each assignment in specific terms;
- allow teachers within schools, school divisions/districts, and the province to collaborate in assessment; and
- play an important part in instruction.

## How Assessment Rubrics Enhance Instruction

The best assessment tools do not simply sort and score student work; instead, they describe it in specific terms. This assessment information

- helps teachers adjust instruction to meet student learning requirements;
- tells students what teachers expect and will look for in their work, and helps them to focus their efforts;
- allows students to assess their own work using the criteria teachers will use to set goals and to monitor their progress; and
- aids in the development of metacognition by giving students a vocabulary for talking about particular aspects of their work.

## Sources of Assessment Rubrics

Teachers develop assessment rubrics in collaboration with students, on their own, and/or with other teachers—or obtain them through published sources.

- ***Classroom Development***

Developing assessment rubrics in collaboration with students can be a time-consuming process, but one that has many benefits in instruction and learning. (Both the benefits and the process are explored on the following pages.) Although it may not be possible to involve students in the process in every instance, some experience in developing rubrics will help students to use ready-made rubrics with more understanding.

- ***Teacher-Developed***

Teachers develop general performance and product rubrics individually, in collaboration within a school or school division. Rubrics must be adapted regularly to accurately reflect student performance levels.

It is important that teacher-developed rubrics use language that students understand, and that teachers provide an example of work at each level of proficiency. These examples (called anchors or exemplars) illustrate for students the descriptive phrases used in the rubrics.

- ***Published Sources***

High-quality assessment rubrics are available in various educational resources. The disadvantage of ready-made rubrics is that they may not be congruent with the learning outcomes targeted in a particular assignment, and may not accurately describe Senior 4 performance levels and criteria.

## Developing Rubrics in Collaboration with Students

### Student Benefits

Developing rubrics in collaboration with students requires students to look at work samples, and to identify the attributes that make some samples successful and others unsuccessful. Teachers assist students by providing them with the vocabulary to articulate the various elements they see, and by ensuring the criteria are comprehensive and consistent with learning outcomes. This process

- requires students to make judgements about the work they see, and identify the qualities of effective writing, speaking, and representing of science concepts; and
- results in an assessment tool that students understand and feel they own—assessment criteria are not perceived as arbitrary or imposed, but rather express students' own observations about what constitutes quality work.

### The Development Process

For their first experience in designing a rubric, ask students to articulate the criteria they use in making judgements about something in everyday life—the quality of a restaurant, for example. The model rubric that they develop for assessing restaurants may help students grasp how the parts of a rubric work.

Students may also find it helpful to develop rubrics after they have done some preliminary work on the assessment task, and so are familiar with the demands of the particular assignment.

The process of developing assessment rubrics in collaboration with students involves numerous steps:

#### 1. *Look at samples.*

Develop assessment rubrics by analyzing genuine samples of student work that illustrate the learning outcomes that the assessment task in question addresses. Samples are usually drawn from student work from previous years, used with permission and with names removed. Beginning teachers who do not have files of samples may need to borrow from colleagues.

Select samples that are clear and characteristic of student work at various levels. Streamline the process by distributing examples at only three levels of proficiency: excellent, adequate, and inadequate. Provide two or three examples of each level. Allow students time to read the examples and to talk about them in groups.

**2. Describe the samples.**

Suggest that students focus on the examples of excellent work first. Pose the question: “What makes this piece successful?” Then ask students to brainstorm attributes of, or criteria for, success. Some of the attributes students list will describe behaviours that are useful in meeting the goals of the work (for example, the topic is stated at the beginning, there are few spelling errors, a graph is used to represent statistical findings).

What rubrics must attempt to articulate, beyond identifying these behaviours, is the essence of a good product or performance. As Wiggins (1995) points out, eye contact may be important in the performance of an oral report, but it is possible to deliver a dreary talk while maintaining eye contact (V1-5: 6). Together with students, identify the salient qualities of works related to science that are engaging and effective. These may be qualities that are harder to define and illustrate (for example, the speaker has moved beyond a superficial understanding of the subject, the producer of a video is aware of the audience, the writer’s voice is discernible in a science journalism piece).

**3. Develop criteria categories.**

From the brainstormed list of attributes, select the criteria categories that will make up the assessment rubric. Most rubrics are limited to three to five criteria categories. A greater number makes the rubrics difficult for assessors to use, especially in assessing live performances. Listing too many criteria can also overwhelm or confuse students who use the rubrics for self-assessment and setting goals.

Develop criteria categories by combining related attributes, and selecting three to five that are considered most important. Label the criteria categories in general terms (organization, style, content) and expand them by listing the specific elements to be examined in assessing quality in these criteria (for example, in the “organization” category, the elements may be “statement of purpose, topic sentences, transition words and phrases, paragraph breaks, order of ideas”).

Ensure that no essential attribute that defines good performance is left out. This means including elements considered hard to assess (such as style or creativity). Ignoring elements such as these signals that they are not important. Addressing them helps students grasp the things they can do to improve their own work in these areas. If graphical analysis is identified as one criteria category, for example, the rubric may list elements that convey the details of such an analysis (for example, placement of dependent and independent variables, placement of data points, line of “best fit”). It may also provide definitions.

As students collaborate to develop criteria categories, monitor whether the criteria chosen are related to the intended learning outcomes.

**4. Decide how many performance levels the rubric will contain.**

The first rubric students develop will have three performance levels, based on identifying student work samples as excellent, adequate, or inadequate. In later rubrics, students may move to finer distinctions between levels. The number of levels needed to make meaningful judgements regarding the full range of proficiency is best decided by the teacher. If the scale is large (seven levels, for example), finer distinctions can be made, but it may be difficult to differentiate clearly one level from the next. In science, assessment rubrics designed to be used by students as well as teachers generally use three, four, or five performance levels.\*

Using the same number of performance levels for various tasks throughout the course has the advantage of giving students and the teacher a common vocabulary in talking about ways to improve performance (for example, “This piece does not have the concrete detail of level 4 writing”). Once the number of criteria categories and performance levels has been determined, a rubric template such as the following can be used in developing rubrics.

		Criteria Categories			
Performance Levels	1				
	2				
	3				
	4				
	5				

---

\* Many designers of rubrics advocate a five-level scale. Levels 1, 3, and 5 are developed from an initial sorting of student work into excellent, adequate, and inadequate samples. Levels 2 and 4 describe work that is between these anchor points. Other educators argue that an even-point scale (four or six levels) forces more care in judging than an odd number does; it prevents assessors from overusing a middle category for work that is difficult to assess.

**5. Describe the performance levels.**

In developing the assessment criteria (Step 3), students analyzed successful pieces of work. They now fill in descriptions of excellent, adequate, and inadequate performance in each criteria category.

There are two ways of describing performance levels:

- Evaluative rubrics use comparative adjectives (for example, “weak organization”).
- Descriptive rubrics specify the qualities of work at each performance level with respect to the criteria (for example, “unconnected ideas appear in the same paragraph”). The attributes listed may be negative (for example, “subscripts and coefficients are incorrectly applied”), for sometimes the most telling characteristic of certain levels is their failure to do what they should be doing.

Descriptive rubrics have many advantages over evaluative rubrics. They are more helpful to students, because they spell out the behaviours and qualities students encounter in assessing their own and others’ work, and the things they can address in their own work in order to improve.

When beginning to write descriptive rubrics, students may suggest generally descriptive adjectives (such as “interesting,” “boring”), which may not convey information about what an interesting piece looks like, and how they can improve their work in this area. The description needs to state the attributes that make a work interesting, and be in an acceptable style for scientific communication. Classes may need to begin by using comparative language or general descriptions. As the students and teacher collect examples, they can then fine-tune the rubric with specific descriptions.

By the end of this step, students will have a description of performance at three levels. If the class has decided to create a rubric with four, five, or six performance levels, it may be most efficient for the teacher to draft gradations of quality for the middle levels, and present them to the class for revision. These middle levels are the most difficult to write, and call on more experience and expertise in developing a smooth continuum of proficiency.

**6. Use the rubric for student self-assessment, for teacher assessment, and for instruction.**

Before using the rubric on an actual assignment, students and teachers may want to test it against unsorted samples of work from previous years. Applying the rubric to student work helps the class determine whether the rubric accurately describes the qualities of the work they see, and helps students make meaningful distinctions between work at different levels of proficiency. As students become more adept at using the rubric, and when they have internalized the performance levels, present them with more diverse samples and assessment challenges.

Rubrics make it possible for students to assess their own work on the basis of the criteria that the teacher will use. Any differences in scores between a student’s and a teacher’s assessment can be the subject of profitable and focussed discussion in student conferences.



If numerical scores are required, point values assigned to each level can be totalled. If the teacher and students decide that certain criteria categories should be more heavily weighted than others, the points assigned to these categories can be multiplied by a factor.

A rubric developed collaboratively can also become a valuable instructional tool, encouraging students to look closely at the specific things they can do to improve a piece of work. If students decide that a writing sample in science is at level 3, they can be asked to work together in groups to improve it so that it fits the description for level 4 work.

**7. *Continue to revise the rubric.***

Any assessment rubric can be considered a work in progress, especially if it is stored on the computer. Both teacher and students should carefully review the rubric each time they use it, asking, “Do these criteria capture the most important qualities of excellence in this work?” “What other words and phrases can we use to describe work at this level?” In keeping with this, the rubrics appearing in Appendix 6 are intended as templates, open to situational revisions.

# APPENDIX 6: ASSESSMENT RUBRICS

## Rubric for the Assessment of Class Presentations

Student Name(s) _____ Topic/Title _____		Performance Levels			
		Level 1	Level 2	Level 3	Level 4
Criteria	Content	<input type="checkbox"/> No understanding of the topic was evident. <input type="checkbox"/> Student(s) did not relate the material presented to their own experiences.	<input type="checkbox"/> Basic understanding of the topic was evident. <input type="checkbox"/> Student(s) attempted to relate the material presented to their own experiences.	<input type="checkbox"/> Good understanding of the topic. <input type="checkbox"/> Knowledge is thorough and detailed. <input type="checkbox"/> Student(s) attempted to relate the material presented to their own experiences.	<input type="checkbox"/> Excellent depth of understanding is evident. <input type="checkbox"/> Student(s) presented material that was additional to what was required. Excellent research. <input type="checkbox"/> Student(s) showed how the material presented relates to their own experiences.
	Interest and Enthusiasm	<input type="checkbox"/> Little interest and enthusiasm for the topic was displayed in the presentation.	<input type="checkbox"/> Some interest and enthusiasm was evident in the presentation. <input type="checkbox"/> The class was not very interested or enthusiastic.	<input type="checkbox"/> The presenters were clearly interested in their topic and their enthusiasm was quite evident. <input type="checkbox"/> The class was noticeably attentive during the presentation.	<input type="checkbox"/> The interest and enthusiasm of the presenter(s) were exceptional. <input type="checkbox"/> The class was keenly attentive during the presentation.
	Clarity and Organization of Material	<input type="checkbox"/> The information presented was confusing.	<input type="checkbox"/> The information was somewhat vague. <input type="checkbox"/> There was some organization.	<input type="checkbox"/> The information was clearly presented. <input type="checkbox"/> The presentation was well organized.	<input type="checkbox"/> All information was relevant and clearly presented. <input type="checkbox"/> The presentation was extremely well organized. <input type="checkbox"/> Main points were emphasized and reinforced with appropriate examples.
	Use of Visual Aids	<input type="checkbox"/> Visual aids were not used.	<input type="checkbox"/> Visual aids were used. <input type="checkbox"/> Visual aids were not well done. <input type="checkbox"/> Visual aids used were somewhat relevant to the presentation.	<input type="checkbox"/> Visual aids were used. <input type="checkbox"/> Visual aids were quite well done. <input type="checkbox"/> Visual aids were relevant to the presentation.	<input type="checkbox"/> Strong visual aids were used. <input type="checkbox"/> Visual aids were extremely well done with colour, clarity, and care. <input type="checkbox"/> Visual aids were designed to emphasize and strengthen the presentation and were successful.

\* Teachers are reminded that this rubric would vary with the assignment and format of the presentation.

# Rubric for the Assessment of a Research Project

Student Name(s) \_\_\_\_\_ Topic/Title \_\_\_\_\_

Criteria	Performance Levels			
	Level 1	Level 2	Level 3	Level 4
Source of Information	<input type="checkbox"/> Student(s) used only one source of information.	<input type="checkbox"/> Student(s) used two sources of information.	<input type="checkbox"/> Student(s) used a variety of sources.	<input type="checkbox"/> Student(s) used a wide variety of sources in a unique manner.
Information Collected	<input type="checkbox"/> The information collected was not relevant.	<input type="checkbox"/> The information collected was relevant to the topic but was not blended into a cohesive piece.	<input type="checkbox"/> The information collected was relevant to the topic and was somewhat organized into a cohesive piece.	<input type="checkbox"/> The information collected was relevant to the topic and was carefully organized into a cohesive piece of research.
Organization of Material	<input type="checkbox"/> The information collected was not organized.	<input type="checkbox"/> The information was somewhat organized.	<input type="checkbox"/> The information was organized and contained recognizable sections.	<input type="checkbox"/> The information was organized and contained recognizable sections that included an introduction, a main body with supporting evidence, and a conclusion that summarized the report.
Presentation of Material	<input type="checkbox"/> The report was handwritten, contrary to established guidelines.	<input type="checkbox"/> The report was neatly handwritten. <input type="checkbox"/> The report contained a bibliography that was not correctly formatted.	<input type="checkbox"/> The report was typed. <input type="checkbox"/> The report contained graphics. <input type="checkbox"/> The report contained a bibliography that was not correctly formatted.	<input type="checkbox"/> The report was typed and appropriately formatted. <input type="checkbox"/> The report contained a title page. <input type="checkbox"/> The report contained relevant graphics. <input type="checkbox"/> The report contained a complete, correctly formatted bibliography.

# Rubric for the Assessment of a Decision-Making Process Activity

Student Name(s) \_\_\_\_\_ Topic/Title \_\_\_\_\_

Criteria	Performance Levels			
	Level 1	Level 2	Level 3	Level 4
Identification of STSE Issue	<ul style="list-style-type: none"> <li><input type="checkbox"/> Student(s) cannot identify an STSE issue without assistance.</li> </ul>	<ul style="list-style-type: none"> <li><input type="checkbox"/> Student(s) have a basic understanding that an issue could have STSE implications, not necessarily differentiating among the four areas.</li> </ul>	<ul style="list-style-type: none"> <li><input type="checkbox"/> Student(s) have a good understanding of a connection between an issue and its STSE applications.</li> <li><input type="checkbox"/> Some evidence of awareness of an individual response.</li> </ul>	<ul style="list-style-type: none"> <li><input type="checkbox"/> Student(s) have excellent depth and sensitivity in connecting an issue with its STSE implications.</li> <li><input type="checkbox"/> A level of social responsibility is demonstrated.</li> </ul>
Evaluates Current Research on Issue	<ul style="list-style-type: none"> <li><input type="checkbox"/> Student(s) are able to access a small amount of current research, with no evaluation of that research evident.</li> </ul>	<ul style="list-style-type: none"> <li><input type="checkbox"/> Student(s) demonstrate some ability to recognize the positions taken in the research data, with no clear evaluative statements.</li> </ul>	<ul style="list-style-type: none"> <li><input type="checkbox"/> Student(s) have secured an array of research, narrow in its scope, but clearly identify the positions taken.</li> <li><input type="checkbox"/> Student(s) can offer personal opinions on issue, not necessarily evaluation.</li> </ul>	<ul style="list-style-type: none"> <li><input type="checkbox"/> All acquired research of student(s) is current, relevant, and from a variety of perspectives.</li> <li><input type="checkbox"/> Student(s) demonstrate insight into the stated positions, and can frame an evaluation.</li> </ul>
Formulates Possible Options	<ul style="list-style-type: none"> <li><input type="checkbox"/> Student(s) are unable to clearly identify the possible options.</li> <li><input type="checkbox"/> Student(s) can form options that are not clearly connected to the problem to be solved.</li> </ul>	<ul style="list-style-type: none"> <li><input type="checkbox"/> Student(s) can offer at least one feasible option connected to the problem.</li> <li><input type="checkbox"/> Student(s) can offer other options that may be more or less related directly to the problem.</li> </ul>	<ul style="list-style-type: none"> <li><input type="checkbox"/> Student(s) develop at least two feasible options that are internally consistent, and directly address the problem.</li> <li><input type="checkbox"/> Student(s) recognize that some options will fail.</li> </ul>	<ul style="list-style-type: none"> <li><input type="checkbox"/> Student(s) display a level of sophistication of feasible options that is beyond expectations.</li> <li><input type="checkbox"/> All options demonstrate a reasonable chance of succeeding at being chosen.</li> </ul>
Identifies Projected Impacts	<ul style="list-style-type: none"> <li><input type="checkbox"/> Student(s) are not able to foresee the possible consequences of the options selected.</li> <li><input type="checkbox"/> There appears to be a naïve awareness of consequences.</li> </ul>	<ul style="list-style-type: none"> <li><input type="checkbox"/> Student(s) identify potential impacts of decisions taken in a vague or insubstantial way.</li> <li><input type="checkbox"/> Most of the feasible options are viewed as having projected impacts.</li> </ul>	<ul style="list-style-type: none"> <li><input type="checkbox"/> Student(s) can identify potential impacts of decisions taken in an organized way.</li> <li><input type="checkbox"/> All the feasible options are viewed as having projected impacts: some beneficial, some not.</li> </ul>	<ul style="list-style-type: none"> <li><input type="checkbox"/> Student(s) are capable of offering a cost/benefits/risks analysis of each feasible solution.</li> <li><input type="checkbox"/> Student(s) can construct an organized report that clearly outlines the impacts of each option.</li> </ul>

\* Teachers are reminded that the above criteria are suggestions only, and will be adapted according to the needs of the assignment. It is preferable if this rubric is modified in consultation with the students, leading to clarity of purpose.

# Rubric for the Assessment of a Decision-Making Process Activity (continued)

Student Name(s) _____ Topic/Title _____		Performance Levels			
		Level 1	Level 2	Level 3	Level 4
Criteria					
Selects an Option and Makes a Decision	<ul style="list-style-type: none"> <li><input type="checkbox"/> Student(s) are unable to come to a decision that clearly connects with the problem to be solved.</li> <li><input type="checkbox"/> Student(s) require direction from the outside to make a choice.</li> </ul>	<ul style="list-style-type: none"> <li><input type="checkbox"/> Student(s) can identify a feasible option, but are faced with the inability to clearly decide on a plan.</li> <li><input type="checkbox"/> Student(s) still require outside influences to stand by a decision to proceed.</li> </ul>	<ul style="list-style-type: none"> <li><input type="checkbox"/> Student(s) clearly select an option, decide on a course of action, but others can identify that a better course of action remains untried.</li> <li><input type="checkbox"/> Student(s) recognize potential safety concerns.</li> </ul>	<ul style="list-style-type: none"> <li><input type="checkbox"/> Student(s) collaboratively perform a thorough analysis of all options.</li> <li><input type="checkbox"/> Student(s) make a firm decision that is justified by the research base and recognize most of the safety concerns.</li> </ul>	
Implements the Decision	<ul style="list-style-type: none"> <li><input type="checkbox"/> Student(s) are unable to fully implement the decision, but the opportunity to modify it remains.</li> <li><input type="checkbox"/> Student(s) show a lack of clarity in their decisions to proceed.</li> </ul>	<ul style="list-style-type: none"> <li><input type="checkbox"/> Student(s) implement the decision with a recognition that not all details are laid out in advance.</li> <li><input type="checkbox"/> Student(s) demonstrate some lack of clarity in having a plan for implementation.</li> </ul>	<ul style="list-style-type: none"> <li><input type="checkbox"/> Student(s) implement with some visible clarity of purpose.</li> <li><input type="checkbox"/> Student(s) demonstrate confidence that the plan will be one that can be of a scientific inquiry approach.</li> </ul>	<ul style="list-style-type: none"> <li><input type="checkbox"/> Student(s) implement a plan with visible clarity of purpose, backed by the research base.</li> <li><input type="checkbox"/> Student(s) clearly demonstrate that the plan will be one that can be carried to completion as inquiry.</li> </ul>	
Identifies and Evaluates Actual Impacts of Decision	<ul style="list-style-type: none"> <li><input type="checkbox"/> Student(s) are unable to clearly recognize more than one possible actual impact.</li> <li><input type="checkbox"/> Student(s) cannot effectively evaluate the effects of the decision(s) taken.</li> </ul>	<ul style="list-style-type: none"> <li><input type="checkbox"/> Student(s) can clearly recognize more than one possible actual impact for the decision taken.</li> <li><input type="checkbox"/> Student(s) cannot effectively evaluate the effects of the decision(s) taken in most instances.</li> </ul>	<ul style="list-style-type: none"> <li><input type="checkbox"/> Student(s) are able to recognize and comment upon the actual impacts observed.</li> <li><input type="checkbox"/> Student(s) exhibit some ability in evaluating the impacts of the decision.</li> </ul>	<ul style="list-style-type: none"> <li><input type="checkbox"/> Student(s) are able to recognize and comment deeply upon the actual impacts observed, noting unforeseen or unique outcomes.</li> <li><input type="checkbox"/> Student(s) exhibit facility in evaluating the impacts of the decision.</li> </ul>	
Reflects on the Decision Making and Implementation of a Plan	<ul style="list-style-type: none"> <li><input type="checkbox"/> Student(s) begin to demonstrate an awareness of the need to review the plan.</li> <li><input type="checkbox"/> Student(s) demonstrate a reluctance to consider a re-evaluation of the plan.</li> </ul>	<ul style="list-style-type: none"> <li><input type="checkbox"/> Student(s) reflect and intend to communicate the results of the implementation plan.</li> <li><input type="checkbox"/> Student(s) have some difficulty in how to proceed with a re-evaluation of the problem-solving plan.</li> </ul>	<ul style="list-style-type: none"> <li><input type="checkbox"/> Student(s) reflect upon and communicate the results of the implementation plan.</li> <li><input type="checkbox"/> Student(s) recognize how to proceed with a re-evaluation of the problem-solving plan.</li> </ul>	<ul style="list-style-type: none"> <li><input type="checkbox"/> Student(s) demonstrate that a higher order synthesis was visible in the reflection process.</li> <li><input type="checkbox"/> Student(s) exhibit evidence of a sophisticated environmental awareness that informs this post-implementation period.</li> </ul>	

\* Teachers are reminded that the above criteria are suggestions only and will be adapted according to the needs of the assignment. It is preferable if this rubric is modified in consultation with the students, leading to clarity of purpose.

## Lab Report Assessment

Project Title \_\_\_\_\_ Date \_\_\_\_\_

Team Members \_\_\_\_\_

Area of Interest	Possible Points	Self	Teacher
<p><b>Formulates Testable Questions:</b> Question is testable and focussed with cause-and-effect relationship identified.</p>			
<p><b>Formulates a Prediction/Hypothesis:</b> Independent and dependent variables are identified and the prediction/hypothesis clearly identifies a cause-and-effect relationship between these two variables.</p>			
<p><b>Creates a Plan:</b> All steps are included and clearly described in a logical sequence. All required materials/equipment are identified. Safety considerations are addressed; major intervening variables are controlled.</p>			
<p><b>Conducts a Fair Test and Records Observations:</b> There is evidence of repeated trials and the inclusion of all data. Detailed data are recorded, and appropriate units are used; data are recorded in a clear/well-structured/appropriate format for later reference.</p>			
<p><b>Interprets and Evaluates Results:</b> Patterns/trends/discrepancies are identified. Strengths and weaknesses of approach and potential sources of error are identified. Changes to the original plan are identified and justified.</p>			
<p><b>Draws a Conclusion:</b> Conclusion explains cause-and-effect relationship between dependent and independent variables; alternative explanations are identified; hypothesis is supported or rejected.</p>			
<p><b>Makes Connections:</b> Potential applications are identified and/or links to area of study are made.</p>			
<p><b>Total Points</b></p>			



# Rubric for Student Presentation

Student Name(s) _____ Topic/Title _____		Performance Levels			
		Level 1	Level 2	Level 3	Level 4
<b>Criteria</b>					
<b>Organization</b>	<input type="checkbox"/> Presentation shows poor organization and lack of preparation.	<input type="checkbox"/> Presentation shows signs of organization but some parts do not seem to fit the topic.	<input type="checkbox"/> Presentation is organized, logical, and interesting.	<input type="checkbox"/> Presentation is very well organized, logical, interesting, and lively.	
<b>Preparation</b>	<input type="checkbox"/> Some student preparation is shown.	<input type="checkbox"/> A fair amount of student preparation is shown.	<input type="checkbox"/> An adequate amount of student preparation is shown.	<input type="checkbox"/> A great deal of student preparation is shown.	
<b>Content</b>	<input type="checkbox"/> Small amount of material presented is related to the topic.	<input type="checkbox"/> Some material presented is not related to the topic.	<input type="checkbox"/> Almost all material presented is related to the topic.	<input type="checkbox"/> All material in the presentation is related to the topic.	
<b>Language</b>	<input type="checkbox"/> Language used is hard to follow and understand.	<input type="checkbox"/> Some language used is hard to follow and understand.	<input type="checkbox"/> Most language used is easy to follow and understand.	<input type="checkbox"/> Language used is well chosen and easy to follow and understand.	
<b>Format</b>	<input type="checkbox"/> Poor use of aids and support materials (diagrams, overheads, maps, pictures); does not support the topic.	<input type="checkbox"/> Adequate use of aids and support materials; most support the topic.	<input type="checkbox"/> Good use of aids and support materials; almost all support the topic.	<input type="checkbox"/> Excellent use of aids and support materials; all aids support the topic.	
<b>Delivery</b>	<input type="checkbox"/> Many words are unclear; voice is monotonous; spoken too quickly or slowly; no pausing for emphasis; voice is too low to be heard easily.	<input type="checkbox"/> Some words are unclear; voice is somewhat varied; spoken too quickly at times; some pausing for emphasis; voice is sometimes too low to be heard easily.	<input type="checkbox"/> Most words are clear; voice is often varied, interesting, generally spoken at the correct speed; frequent pausing for emphasis; voice is loud enough to be heard easily.	<input type="checkbox"/> Words are clear; voice is frequently varied, interesting, generally spoken at the correct speed; effective pausing for emphasis; voice is loud enough to be heard easily.	
<b>Audience</b>	<input type="checkbox"/> Audience is not involved or interested.	<input type="checkbox"/> Audience is somewhat involved, sometimes interested.	<input type="checkbox"/> Audience is involved and interested.	<input type="checkbox"/> Audience is very involved and interested.	

\* Teachers are reminded that the above criteria are suggestions only, and will be adapted according to the needs of the assignment. It is preferable if this rubric is modified in consultation with the students, leading to clarity of purpose.



# Rubric for Research Skills

Student Name(s) \_\_\_\_\_ Topic/Title \_\_\_\_\_

Research Skills	Performance Levels			
	Level 1	Level 2	Level 3	Level 4
Ability to formulate questions to identify problems for research purposes	<input type="checkbox"/> Shows limited ability	<input type="checkbox"/> Shows some ability	<input type="checkbox"/> Shows general ability	<input type="checkbox"/> Shows consistent and thorough ability
Ability to locate relevant primary and secondary sources of information	<input type="checkbox"/> Unable to locate	<input type="checkbox"/> Somewhat able to locate	<input type="checkbox"/> Generally able to locate	<input type="checkbox"/> Always or almost always able to locate
Ability to locate and record relevant information from a variety of sources	<input type="checkbox"/> Unable to locate and record	<input type="checkbox"/> Somewhat able to locate	<input type="checkbox"/> Generally able to locate and record	<input type="checkbox"/> Always or almost always able to locate and record
Ability to organize information related to identified problem(s)	<input type="checkbox"/> Shows limited ability	<input type="checkbox"/> Shows some ability	<input type="checkbox"/> Shows general ability	<input type="checkbox"/> Shows consistent and thorough ability
Ability to analyze and synthesize information related to identified problems	<input type="checkbox"/> Shows limited ability	<input type="checkbox"/> Shows some ability	<input type="checkbox"/> Shows general ability	<input type="checkbox"/> Shows consistent and thorough ability
Ability to communicate results of inquiries using a variety of appropriate presentation forms (oral, media, written, graphic, pictorial, other)	<input type="checkbox"/> Unable to communicate	<input type="checkbox"/> Somewhat able to communicate	<input type="checkbox"/> Generally able to communicate	<input type="checkbox"/> Always or almost always able to communicate

\*Teachers are reminded that this rubric would vary with the assignment and format of the presentation.

---

## **APPENDIX 7: GENERAL LEARNING OUTCOMES**

### **Nature of Science and Technology**

- A1. recognize both the power and limitations of science as a way of answering questions about the world and explaining natural phenomena
- A2. recognize that scientific knowledge is based on evidence, models, and explanations, and evolves as new evidence appears and new conceptualizations develop
- A3. distinguish critically between science and technology in terms of their respective contexts, goals, methods, products, and values
- A4. identify and appreciate contributions made by women and men from many societies and cultural backgrounds toward increasing our understanding of the world and in bringing about technological innovations
- A5. recognize that science and technology interact with and advance one another

### **Science, Technology, Society, and the Environment (STSE)**

- B1. describe scientific and technological developments, past and present, and appreciate their impact on individuals, societies, and the environment, both locally and globally
- B2. recognize that scientific and technological endeavours have been and continue to be influenced by human needs and the societal context of the time
- B3. identify the factors that affect health and explain the relationships among personal habits, lifestyle choices, and human health, both individual and social
- B4. demonstrate a knowledge of, and personal consideration for, a range of possible science- and technology-related interests, hobbies, and careers
- B5. identify and demonstrate actions that promote a sustainable environment, society, and economy, both locally and globally

### **Scientific and Technological Skills and Attitudes**

- C1. recognize safety symbols and practices related to scientific and technological activities and to their daily lives, and apply this knowledge in appropriate situations
- C2. demonstrate appropriate scientific inquiry skills when seeking answers to questions
- C3. demonstrate appropriate problem-solving skills while seeking solutions to technological challenges
- C4. demonstrate appropriate critical thinking and decision-making skills when choosing a course of action based on scientific and technological information
- C5. demonstrate curiosity, skepticism, creativity, open-mindedness, accuracy, precision, honesty, and persistence, and appreciate their importance as scientific and technological habits of mind
- C6. employ effective communication skills and utilize information technology to gather and share scientific and technological ideas and data

- C7. work co-operatively and value the ideas and contributions of others while carrying out scientific and technological activities
- C8. evaluate, from a scientific perspective, information and ideas encountered during investigations and in daily life

### **Essential Science Knowledge**

- D1. understand essential life structures and processes pertaining to a wide variety of organisms, including humans
- D2. understand various biotic and abiotic components of ecosystems, as well as their interaction and interdependence within ecosystems and within the biosphere as a whole
- D3. understand the properties and structures of matter as well as various common manifestations and applications of the actions and interactions of matter
- D4. understand how stability, motion, forces, and energy transfers and transformations play a role in a wide range of natural and constructed contexts
- D5. understand the composition of the Earth's atmosphere, hydrosphere, and lithosphere, as well as the processes involved within and among them
- D6. understand the composition of the universe, the interactions within it, and the impacts of humankind's continued attempts to understand and explore it

### **Unifying Concepts**

- E1. describe and appreciate the similarity and diversity of forms, functions, and patterns within the natural and constructed world
- E2. describe and appreciate how the natural and constructed worlds are made up of systems and how interactions take place within and among these systems
- E3. recognize that characteristics of materials and systems can remain constant or change over time, and describe the conditions and processes involved
- E4. recognize that energy, whether transmitted or transformed, is the driving force of both movement and change, and is inherent within materials and in the interactions among them

## APPENDIX 8: SPECIFIC LEARNING OUTCOMES

### Cluster “0”—Skills and Attitudes Outcomes

#### Nature of Science

- S4P-0-1a Explain the roles of theory, evidence, and models in the development of scientific knowledge.
- S4P-0-1b Describe the importance of peer review in the evaluation and acceptance of scientific theories, evidence, and knowledge claims.
- S4P-0-1c Relate the historical development of scientific ideas and technology to the form and function of scientific knowledge today.
- S4P-0-1d Describe how scientific knowledge changes as new evidence emerges and/or new ideas and interpretations are advanced.
- S4P-0-1e Differentiate between how scientific theories explain natural phenomena and how scientific laws identify regularities and patterns in nature.

#### Inquiry Skills

- S4P-0-2a Select and use appropriate visual, numeric, graphical, and symbolic modes of representation to identify and represent relationships.
- S4P-0-2b Propose problems, state hypotheses, and plan, implement, adapt, or extend procedures to carry out an investigation where required.
- S4P-0-2c Formulate operational definitions of major variables or concepts.
- S4P-0-2d Estimate and measure accurately using SI units.
- S4P-0-2e Evaluate the relevance, reliability, and adequacy of data and data-collection methods.  
Include: discrepancies in data and sources of error
- S4P-0-2f Record, organize, and display data using an appropriate format.  
Include: labelled diagrams, tables, graphs
- S4P-0-2g Develop mathematical models involving linear, power, and/or inverse relationships among variables.
- S4P-0-2h Analyze problems using vectors.  
Include: Adding and subtracting vectors in straight lines, at right angles, and at non-orthogonal angles
- S4P-0-2i Select and integrate information obtained from a variety of sources.  
Include: print, electronic, specialists, or other resource people

### Science, Technology, Society, and the Environment (STSE)

- S4P-0-3a Analyze, from a variety of perspectives, the risks and benefits to society and the environment when applying scientific knowledge or introducing technology.
- S4P-0-3b Describe examples of how technology has evolved in response to scientific advances, and how scientific knowledge has evolved as the result of new innovations in technology.
- S4P-0-3c Identify social issues related to science and technology, taking into account human and environmental needs and ethical considerations.
- S4P-0-3d Use the decision-making process to address an STSE issue.
- S4P-0-3e Identify a problem, initiate research, and design a technological or other solution to address the problem.

### Attitudes

- S4P-0-4a Demonstrate work habits that ensure personal safety, the safety of others, and consideration of the environment.
- S4P-0-4b Work co-operatively with a group to identify prior knowledge, initiate and exchange ideas, propose problems and their solution, and carry out investigations.
- S4P-0-4c Demonstrate confidence in their ability to carry out investigations in science and to address STSE issues.
- S4P-0-4d Develop a sense of personal and shared responsibility for the impact of humans on the environment, and demonstrate concern for social and environmental consequences of proposed actions.
- S4P-0-4e Demonstrate a continuing and more informed interest in science and science-related issues.
- S4P-0-4f Value skepticism, honesty, accuracy, precision, perseverance, and open-mindedness as scientific and technological habits of mind.

## Topic One: Mechanics

### Topic 1.1: Kinematics

- S4P-1-1 Derive the special equations for constant acceleration.

Include:  $\vec{a} = \frac{\Delta \vec{v}}{\Delta t}$ ;  $\Delta \vec{d} = \vec{v}_1 \Delta t + \frac{1}{2} \vec{a} \Delta t^2$ ;  $v_2^2 = v_1^2 + 2a\Delta d$

- S4P-1-2 Solve problems for objects moving in a straight line with a constant acceleration.

Include:  $\vec{v}_2 = \vec{v}_1 + \vec{a} \Delta t$ ;  $\Delta \vec{d} = \vec{v}_1 \Delta t + \frac{1}{2} \vec{a} \Delta t^2$ ;  $v_2^2 = v_1^2 + 2a\Delta d$ ;  $\Delta \vec{d} = \left( \frac{\vec{v}_1 + \vec{v}_2}{2} \right) \Delta t$

- S4P-1-3 Solve relative motion problems for constant velocities using vectors.

**Topic 1.2: Dynamics**

- S4P-1-4 Solve vector problems for objects in equilibrium.
- S4P-1-5 Calculate the forces acting on an object resting on an inclined plane.  
Include: normal force, friction, components of the gravitational force ( $mg$ )
- S4P-1-6 Calculate the components of  $\vec{F}_{\text{gravity}}$  exerted on an object resting on an inclined plane.
- S4P-1-7 Solve problems with  $\vec{F}_{\text{friction}}$  for objects on a horizontal surface and on an inclined plane.  
Include: coefficient of friction
- S4P-1-8 Solve problems using  $\vec{F}_{\text{net}} = m\vec{a}$  where  $\vec{F}_{\text{net}} = \vec{F}_{\text{applied}} + \vec{F}_{\text{friction}}$  and using kinematics equations from above.  
Include:  $\vec{F}_{\text{applied}}$  at an angle to horizontal motion; combined mass systems;  $\vec{F}_{\text{applied}}$  on an inclined plane; forces acting at various angles on a body
- S4P-1-9 Perform an experiment to investigate forces acting on an object.

**Topic 1.3: Momentum**

- S4P-1-10 Derive the impulse-momentum equation from Newton's second law.
- S4P-1-11 Determine impulse from the area under a force-time graph.  
Include: constant positive and negative force, uniformly changing force
- S4P-1-12 Experiment to illustrate the Law of Conservation of Momentum in one and two dimensions.
- S4P-1-13 Solve problems using the impulse-momentum equation and the Law of Conservation of Momentum.
- S4P-1-14 Relate the impulse-momentum equation to real-life situations.  
*Examples: hitting a ball, catching a ball*

**Topic 1.4: Projectile Motion**

- S4P-1-15 Solve simple free-fall problems using the special equations for constant acceleration.  
Include: horizontal and vertical components of motion of the curved path of a projectile (without air resistance)
- S4P-1-16 Draw free-body diagrams for a projectile at various points along its path (with or without air resistance).
- S4P-1-17 Calculate the horizontal and vertical components with respect to velocity and position of a projectile at various points along its path.
- S4P-1-18 Solve problems for projectiles launched horizontally and at various angles to the horizontal to calculate maximum height, range, and overall time of flight of the projectile.

### Topic 1.5: Circular Motion

- S4P-1-19 Explain qualitatively why an object moving at a constant speed in a circle is accelerating toward the centre of the circle.
- S4P-1-20 Discuss the centrifugal effects with respect to Newton's laws.
- S4P-1-21 Draw free-body diagrams of an object moving in uniform circular motion.
- S4P-1-22 Experiment to determine the mathematical relationship between period and frequency and one or more of the following: centripetal force, mass, and radius.
- S4P-1-23 Derive an equation for the constant speed and acceleration of an object moving in a circle  $\left( \vec{v} = \frac{2\pi r}{T}, a = \frac{v^2}{R} \right)$ .
- S4P-1-24 Solve problems for an object moving with a constant speed in a circle using  $a = \frac{v^2}{R}$ ,  $\vec{v} = \frac{2\pi r}{T}$ , and  $\vec{F}_{\text{net}} = m\vec{a}$ .

### Topic 1.6: Work and Energy

- S4P-1-25 Define work as the product of displacement and the component of force parallel to the displacement when the force is constant.
- S4P-1-26 Determine work from the area under the force-position graph for any force.  
Include: positive or negative force, uniformly changing force
- S4P-1-27 Describe work as a transfer of energy.  
Include: positive and negative work, kinetic energy, conservation of energy
- S4P-1-28 Give examples of various forms of energy and describe qualitatively the means by which they can perform work.
- S4P-1-29 Derive the equation for kinetic energy using  $W = \vec{F} \cdot \Delta \vec{d} \cos \theta$  and kinematics equations.
- S4P-1-30 Derive the equation for gravitational potential energy near the surface of the Earth ( $E_p = mgh$ ).
- S4P-1-31 Experiment to determine Hooke's Law  $\left( \vec{F} = -k \vec{x} \right)$ .
- S4P-1-32 Derive an equation for the potential energy of a spring, using Hooke's law and a force-displacement graph.
- S4P-1-33 Solve problems related to the conservation of energy.  
Include: gravitational and spring potential, and kinetic energy

## Topic 2: Fields

### Topic 2.1: Exploration of Space

S4P-2-1 Identify and analyze issues pertaining to space exploration.

*Examples: scale of the universe, technological advancement, promotion of global co-operation, social and economic benefits, allocation of resources shifted away from other pursuits, possibility of disaster*

S4P-2-2 Describe planetary motion using Kepler's three laws.

*Examples: relate Kepler's Third Law to objects other than planets, such as comets, satellites, and spacecraft*

S4P-2-3 Outline Newton's Law of Universal Gravitation and solve problems using

$$F_g = \frac{Gm_1m_2}{r^2}.$$

S4P-2-4 State the gravitational potential energy as the area under the force-separation curve and solve problems using  $E_g = \frac{-Gm_1m_2}{r}$ .

S4P-2-5 Solve problems for the escape velocity of a spacecraft.

Include: Law of Conservation of Energy, binding energy

### Topic 2.2: Low Earth Orbit

S4P-2-6 Compare the Law of Universal Gravitation with the weight (mg) of an object at various distances from the surface of the Earth and describe the gravitational

field as  $g = \frac{Gm_{\text{Earth}}}{r^2}$ .

S4P-2-7 Outline Newton's thought experiment regarding how an artificial satellite can be made to orbit the Earth.

S4P-2-8 Use the Law of Universal Gravitation and circular motion to calculate the characteristics of the motion of a satellite.

Include: orbital period, speed, altitude above a planetary surface, mass of the central body, and the location of geosynchronous satellites

S4P-2-9 Define microgravity as an environment in which the apparent weight of a system is smaller than its actual weight.

S4P-2-10 Describe conditions under which microgravity can be produced.

*Examples: jumping off a diving board, roller-coaster, free fall, parabolic flight, orbiting spacecraft*

S4P-2-11 Outline the factors involved in the re-entry of an object into Earth's atmosphere.

Include: friction and g-forces

S4P-2-12 Describe qualitatively some of the technological challenges to exploring deep space.

*Examples: communication, flyby and the "slingshot" effect, Hohmann Transfer orbits (least-energy orbits)*



### Topic 2.3: Electric and Magnetic Fields

- S4P-2-13 Compare and contrast the inverse square nature of gravitational and electric fields.
- S4P-2-14 State Coulomb’s Law and solve problems for more than one electric force acting on a charge.  
Include: one and two dimensions
- S4P-2-15 Illustrate, using diagrams, how the charge distribution on two oppositely charged parallel plates results in a uniform field.
- S4P-2-16 Derive an equation for the electric potential energy between two oppositely charged parallel plates ( $E_e = qE\Delta d$ ).
- S4P-2-17 Describe electric potential as the electric potential energy per unit charge.
- S4P-2-18 Identify the unit of electric potential as the volt.
- S4P-2-19 Define electric potential difference (voltage) and express the electric field between two oppositely charged parallel plates in terms of voltage and the separation between the plates  $\left( \varepsilon = \frac{\Delta V}{d} \right)$ .
- S4P-2-20 Solve problems for charges moving between or through parallel plates.
- S4P-2-21 Use hand rules to describe the directional relationships between electric and magnetic fields and moving charges.
- S4P-2-22 Describe qualitatively various technologies that use electric and magnetic fields.  
*Examples: electromagnetic devices (such as a solenoid, motor, bell, or relay), cathode ray tube, mass spectrometer, antenna*

### Topic 3: Electricity

#### Topic 3.1: Electric Circuits

- S4P-3-1 Describe the origin of conventional current and relate its direction to the electron flow in a conductor.
- S4P-3-2 Describe the historical development of Ohm’s Law.  
Include: contributions of Gray, Ohm, Joule, and Kirchoff
- S4P-3-3 Investigate the relationships among resistance and resistivity, length, cross-section, and temperature.  
Include:  $R = \frac{\rho L}{A}$
- S4P-3-4 Demonstrate the ability to construct circuits from schematic diagrams for series, parallel, and combined networks.  
Include: correct placement of ammeters and voltmeters

- S4P-3-5 Calculate the total resistance for resistors in series and resistors in parallel.
- S4P-3-6 Calculate the resistance, current, voltage, and power for series, parallel, and combined networks.

Include:  $P = IV$ ,  $P = I^2R$ , and  $P = \frac{V^2}{R}$

### Topic 3.2: Electromagnetic Induction

- S4P-3-7 Define magnetic flux ( $\Phi = B_{\perp}A$ ).
- S4P-3-8 Demonstrate how a change in magnetic flux induces voltage.
- S4P-3-9 Calculate the magnitude of the induced voltage in coils using  $V = \frac{N\Delta\Phi}{\Delta t}$ .
- S4P-3-10 Outline Lenz's Law and apply to related problems.
- S4P-3-11 Describe the operation of an AC generator.
- S4P-3-12 Graph voltage versus angle for the AC cycle.
- S4P-3-13 Describe the operation of transformers.
- S4P-3-14 Solve problems using the transformer ratio of  $\frac{V_p}{V_s} = \frac{N_p}{N_s}$ .
- S4P-3-15 Describe the generation, transmission, and distribution of electricity in Manitoba.

Include: step-up and step-down transformers, power transfer, High Voltage Direct Current

### Topic 4: Medical Physics

- S4P-4-1 Describe the nuclear model of the atom.  
Include: proton, neutron, nucleus, nuclear forces, stability, isotope, mass number, electron, ion
- S4P-4-2 Define radioactivity as a nuclear change that releases energy.  
Include: Becquerel units, radioactive decay, half life
- S4P-4-3 Perform decay calculations using integer numbers of half life.
- S4P-4-4 Describe the following types of radiation: alpha, beta, and electromagnetic radiation.  
Include: particle radiation, wave radiation, electromagnetic spectrum, linear energy transfer
- S4P-4-5 Compare and contrast sources and characteristics of ionizing radiation and non-ionizing radiation.  
Include: NORM (Naturally Occurring Radioactive Materials), radon, background radiation, incandescent light bulb, hot objects
- S4P-4-6 Describe various applications of non-ionizing radiation.  
*Examples: communications, microwave oven, laser, tanning bed*

- S4P-4-7 Describe various applications of ionizing radiation.  
*Examples: food irradiation, sterilization, smoke alarm*
- S4P-4-8 Describe the effects of non-ionizing and ionizing radiation on the human body.  
Include: equivalency of sievert (Sv) and rem units, solar erythema (sunburn)
- S4P-4-9 Research, identify, and examine the application of radiation to diagnostic imaging and treatment techniques.  
*Examples: nuclear medicine imaging techniques such as MRI, ultrasound, endoscopy, X-ray, CT scanning, PET, heavy isotopes such as Ba; nuclear medicine therapies such as brachithery, external beam, gamma knife*

---

## ***BIBLIOGRAPHY***

---

## BIBLIOGRAPHY

- Alberta Education. *Workshop Materials*. Alberta Education. Edmonton, AB: 1989.
- Arons, Arnold B. *A Guide to Introductory Physics Teaching*. New York, NY: Wiley, 1990.
- Bonham, S. "Using Physlets to Teach Electrostatics." *The Physics Teacher* 37.5 (May 1999): 276.
- Bransford, John D., Ann L. Brown, and Rodney R. Cocking, eds. *How People Learn: Brain, Mind, Experience, and School: Expanded Edition: A National Research Council Report*. Washington, DC: National Academy Press, 2000.
- Brush, Steven. "Whole Earth History." *Historical Studies in the Physical Sciences* 17.2 (1997): 345-355. Available online at: <http://punsterproductions.com/~sciencehistory/WEH.htm>
- Bybee, Rodger W., C. Edward Buchwald, Sally Crissman, David R. Heil, Paul J. Kuerbis, Carolee Matsumoto, and Joseph P. McInerney. In *Science and Technology Education for the Elementary Years: Frameworks for Curriculum and Instruction*. Rowley, MA: The NETWORK Inc., 1989.
- Champagne, A.B., R.F. Gunstone, and L.E. Klopfer. "Instructional Consequences of Students' Knowledge about Physical Phenomena." *Cognitive Structure and Conceptual Change*. ed. L.H.T. West and A.L. Pines. New York, NY: Academic Press, 1985.
- Clement, John. "A Conceptual Model Discussed by Galileo and Used Intuitively by Physics Students." In *Mental Models*. Ed. Dedre Gentner and Albert L. Stevens. London, UK: Lawrence Erlbaum Associates, 1983.
- Corno, Lyn, and Judi Randi. "Motivation, Volition, and Collaborative Innovation in Classroom Literacy." In *Reading Engagement: Motivating Readers through Integrated Sources*. Ed. John T. Guthrie, and Allan Wigfield. Newark, DE: International Reading Association, 1997.
- Council of Ministers of Education, Canada. *Common Framework of Science Learning Outcomes K to 12: Pan-Canadian Protocol for Collaboration on School Curriculum*. Toronto, ON: Council of Ministers of Education, Canada, 1997.
- Court, J. "Free Body Diagrams." *The Physics Teacher* 31.2 (1993): 104.
- . "Free Body Diagrams." *The Physics Teacher* 37.7 (1999): 427.
- Dick, Greg, et al. *Physics 12*. Toronto, ON: McGraw-Hill Ryerson, 2003.
- Drake, Susan M. *Planning Integrated Curriculum: The Call to Adventure*. Alexandria VI: Association for Supervision and Curriculum Development, 1993.
- Ellis, Edwin S., Donald D. Deshler, B. Keith Lenz, Jean B. Shumaker, and Francis L. Clark. "An Instructional Model for Teaching Learning Strategies." *Focus on Exceptional Children* 23.6 (Feb. 1991): 1-22.
- Evans, L., and J. Stevens. "Which Way Is Up?" *The Physics Teacher* 16.8 (1978): 561.

- Fisher, K. "Exercise in Drawing and Utilizing Free-Body Diagrams." *The Physics Teacher* 37.7 (1999): 434.
- Foster, Graham. *Student Self-Assessment: A Powerful Process for Helping Students Revise Their Writing*. Markham, ON: Pembroke, 1996.
- Glatthorn, Allan A. *Learning Twice: An Introduction to the Methods of Teaching*. New York, NY: HarperCollins College, 1993.
- Good, Thomas L., and Jero E. Brophy. *Looking in Classrooms*. New York, NY: Harper and Row, 1987.
- Haber-Schaim, Uri, John H. Dodge, and James A. Walter. *PSSC Physics*. 8th ed. New York, NY: D.C. Heath and Company, 1991.
- Hake, R.R. "Interactive Engagement Versus Traditional Methods: A Six-Thousand-Student Survey of Mechanics Test Data for Introductory Physics Courses." *American Journal of Physics* 66.1 (1998): 64-74.
- Halloun, I. "Views about Science and Physics Achievement. The VASS Story." In *Proceedings of the International Conference on Undergraduate Physics Education*. Ed. E.F. Redish and J.S. Rigden. Washington, DC: American Institute of Physics, 1998.
- Hammer, D. "Epistemological Considerations in Teaching Introductory Physics." *Science Education* 79.4 (1995): 393-413.
- . "Discovery Learning and Discovery Teaching." *Cognition and Instruction* 15.4 (1997): 485-529.
- Heimbecker, Brian, et al. *Physics: Concepts and Connections*. Scarborough, ON: Irwin Publishing Ltd., 2003.
- Herreman, W., and R. Huysentruyt. "Measuring the Magnetic Force on a Current Carrying Conductor." *The Physics Teacher* 33.5 (1995): 288.
- Hestenes, David, and Malcolm Wells. "A Mechanics Baseline Test." *The Physics Teacher* 30.3 (1992): 159-166.
- Hestenes, David, Malcolm Wells, and Gregg Swackhamer. "Force Concept Inventory." *The Physics Teacher* 30 (1992): 141-151.
- Hewitt, Paul. *Conceptual Physics*. Upper Saddle River, NJ: Pearson Prentice-Hall, 2002.
- Hewson, P.W. "Epistemological Commitments in the Learning of Science: Examples from Dynamics." *European Journal of Science Education* 7.2 (1985): 163-172.
- Hirsch, Alan. *Physics for a Modern World*. Toronto, ON: John Wiley & Sons, 1986.
- Hirsch, Alan J., et al. *Nelson Physics 12*. Scarborough, ON: Thomson Learning, 2003.
- Hoy, R.R. "A 'Model Minority' Speaks Out on Cultural Shyness." *Science* 262 (1993): 1117-1118.
- Iona, M. "Weight—An Official Definition." *The Physics Teacher* 37.4 (1999): 238.

- Jensen, L. "Apparent Weight Changes in an Elevator." In *A Potpourri of Physics Teaching Ideas*. Ed. Donna Berry Conner. College Park, MD: American Association of Physics Teachers Publications Department, 1986.
- Kagan, D. "Building a Magnetic Levitation Toy." *The Physics Teacher* 31 (1993): 432.
- Kolodny, A. "Colleges Must Recognize Students' Cognitive Styles and Cultural Backgrounds." *Chronicle of Higher Education* 37.21 (1991): A44.
- Kuhn, Thomas. "Objectivity, Value Judgement, and Theory Choice." In *The Essential Tension: Selected Studies in Scientific Tradition and Change*. Chicago, IL: University of Chicago Press, 1977.
- . *The Structure of Scientific Revolutions*. Chicago, IL: University of Chicago Press, 1962.
- Lapp, D. R. "Field Lines Flying Fur." *The Physics Teacher* 34.4 (1996): 252.
- Larochele, Marie, et Jacques Désautels. *Autour de l'idée de science: itinéraires cognitifs d'étudiants et d'étudiantes*. Laval, QC: Presse de l'université Laval, 1992.
- Lederman, Norm G., Fouad Abd-El-Khalick, Randy L. Bell, and Renée S. Schwartz. "Views of Nature of Science Questionnaire: Toward Valid and Meaningful Assessment of Learners' Conceptions of the Nature of Science." *Journal of Research in Science Teaching* 39.6 (2002): 497-521.
- Locke, E.A., and G.P. Latham. *A Theory of Goal Setting and Task Performance*. Englewood Cliffs, NJ: Prentice Hall, 1990.
- Manitoba Education and Training. *A Foundation for Excellence*. Renewing Education: New Directions series. Winnipeg, MB: Manitoba Education and Training, 1995.
- . *Education for a Sustainable Future: A Resource for Curriculum Developers, Teachers, and Administrators*. Winnipeg, MB: Manitoba Education and Training, 2000.
- . *Reporting on Student Progress and Achievement: A Policy Handbook for Teachers, Administrators, and Parents*. Renewing Education: New Directions series. Winnipeg, MB: Manitoba Education and Training, 1997.
- . *Science Safety: A Kindergarten to Senior 4 Resource Manual for Teachers, Schools, and School Divisions*. Renewing Education: New Directions series. Winnipeg, MB: Manitoba Education and Training, 1997.
- . *Senior 2 English Language Arts: A Foundation for Implementation*. Renewing Education: New Directions series. Winnipeg, MB: Manitoba Education and Training, 1998.
- . *Senior 3 English Language Arts: A Foundation for Implementation*. Renewing Education: New Directions series. Winnipeg, MB: Manitoba Education and Training, 1999.
- . *Senior Years Science Teachers' Handbook*. Renewing Education: New Directions series. Winnipeg, MB: Manitoba Education and Training, 1997.

- . *Success for All Learners: A Handbook on Differentiating Instruction: A Resource for Kindergarten to Senior 4*. Renewing Education: New Directions series. Winnipeg, MB: Manitoba Education and Training, 1996.
- . *Technology As a Foundation Skill Area: A Journey Toward Information Technology Literacy: A Resource for Curriculum Developers, Teachers, and Administrators*. Renewing Education: New Directions series. Winnipeg, MB: Manitoba Education and Training, 1998.
- Maxwell, Rhoda J., and Mary J. Meiser. *Teaching English in Middle and Secondary Schools*. 2nd ed. Upper Saddle River, NJ: Prentice Hall, 1997.
- McComas, W.F. "Ten Myths of Science: Reexamining What We Think We Know about the Nature of Science." *School Science and Mathematics* 96 (1996): 10-16.
- McDermott, L.C. "What We Teach and What Is Learned—Closing the Gap." *American Journal of Physics* 59.4 (1991): 301-315.
- McDermott, L.C., and E.F. Redish. "Resource Letter PER-1: Physics Education Research." *American Journal of Physics* 67 (1999): 755-767.
- McDermott, L., and P. Schaffer. "Research as a Guide for Curriculum Development: Part I: An Example from Introductory Electricity." *American Journal of Physics* 60.11 (1992): 994-1003.
- Millar, Robin, and Jonathan Osborne, eds. *Beyond 2000, Science Education for the Future*. London, UK: King's College, 1998. Available online at <http://www.kcl.ac.uk/depsta/education/be2000/be2000.pdf>.
- Minstrell, J. "Teaching Science for Understanding." In *Toward the Thinking Curriculum: Current Cognitive Research*. Ed. L.B. Resnick and I.E. Klopfer. Alexandria, VA: American Society for Curriculum Development, 1989. 129-149.
- Murray, John James. "Historical and Philosophical Perspectives on Teaching the New Global Tectonics." M.Sc.Ed. thesis. Winnipeg, MB: The University of Manitoba, 2002.
- National Academy of Sciences. *Changing Emphases in Assessment of Student Learning*. Washington, DC: National Academy Press, 1996.
- National Research Council. *National Science Education Standards*. Washington, DC: National Academy Press, 1996.
- . *Science Teaching Reconsidered*. Washington, DC: Committee on Undergraduate Science Education. Division on Behavioral and Social Sciences and Education. National Academy Press, 1997.
- Nelson, J. "Kinematics of a Student." *The Physics Teacher* 21.6 (1983): 386.
- Probst, Robert E. *Response and Analysis: Teaching Literature in Junior and Senior High School*. Don Mills, ON: Heinemann, 1988.



- Purcell-Gates, Victoria. "Process Teaching With Direct Instruction and Feedback in a University-Based Clinic." In *Balanced Instruction: Strategies and Skills in Whole Language*. Ed. Ellen McIntyre and Michael Pressley. Norwood, MA: Christopher-Gordon, 1996.
- Redish, E.F., R.N. Steinberg, and J.M. Saul. "The Distribution and Change of Student Expectations in Introductory Physics." In *Proceedings of the International Conference on Undergraduate Physics Education (1996)*. Ed. E.F. Redish and J.S. Rigden. Washington, DC: American Institute of Physics, 1998.
- Reif, F., and J.H. Larkin. "Cognition in Scientific and Everyday Domains: Comparison and Learning Implications." *Journal of Research in Science Teaching* 28 (1991): 733-760.
- Rossing, Thomas. *The Science of Sound*. 2nd ed. New York, NY: Addison Wesley, 1990.
- Roth, W.M., and K.B. Lucas. "From 'Truth' to 'Invented Reality': A Discourse Analysis of High School Physics Students' Talk About Scientific Knowledge." *Journal of Research in Science Teaching* 34.2 (1997): 145-179.
- Ryan, Richard M., James P. Connell, and Edward L. Deci. "A Motivational Analysis of Self-Determination and Self-Regulation in Education." In *Research and Motivation in Education: The Classroom Milieu*. Vol. 2. Ed. Russell Ames and Carole Ames. New York, NY: Academia Press, 1985.
- Saskatchewan Education. *Instructional Approaches: A Framework for Professional Practice*. Regina, SK: Saskatchewan Education, 1991.
- Schunk, Dale H., and Barry Zimmerman. "Developing Self-Efficacious Readers and Writers: The Role of the Social and Self-Regulatory Processes." In *Reading Engagement: Motivating Readers through Integrated Sources*. Ed. John T. Guthrie and Allan Wigfield. Newark, DE: International Reading Association, 1997.
- Silver, E.A., and S.P. Marshall. "Mathematical and Scientific Problem Solving: Findings, Issues, and Educational Implications." In *Dimensions of Thinking and Cognitive Instruction*. Ed. B.J. Jones and L. Idol. Hillsdale, NJ: Lawrence, 1990.
- Spivey, J., "A Versatile Mount for Slinky Wave Demonstrator." In *AAPT Potpourri of Physics Teaching Ideas*. Ed. Donna Berry Conner. College Park, MD: American Association of Physics Teachers Publications Department, 1986.
- Stinner, A. "Contextual Settings, Science Stories, and Large Context Problems: Toward a More Humanistic Science Education." *Science Education* 79.5 (1995): 555-581.
- . "Providing a Contextual Base and a Theoretical Structure to Guide the Teaching of High School Physics." *Physics Education* 29 (1994a): 75.
- . "Science Textbooks and Science Teaching: From Logic to Evidence." *Science Education* 76.1 (1992): 1-16.
- . "The Story of Force: From Aristotle to Einstein." *Physics Education* 29 (1994b): 77-85.
- Stinner, A., and H. Williams. "Conceptual Change, History, and Science Stories." *Interchange* 24.1 (1993): 87-103.

- Strickland, Dorothy S., and Michael R. Strickland. "Language and Literacy: The Poetry Connection." *Language Arts* 74 (March 1997): 201-205.
- Sustainability Manitoba. *Sustainable Development Strategy for Manitoba*. Winnipeg, MB: Sustainability Manitoba, 1998.
- Turner, Julianne C. "Starting Right: Strategies for Engaging Young Literacy Learners." In *Reading Engagement: Motivating Readers through Integrated Sources*. Ed. John T. Guthrie and Allan Wigfield. Newark, DE: International Reading Association, 1997.
- United Nations Educational, Scientific and Cultural Organization (UNESCO). *Le développement durable grace a l'éducation relative a l'environnement, Connexion* 13.2. Paris, France: UNESCO, June 1988.
- van Zee, E.H., and J.A. Minstrell. "Reflective Discourse: Developing Shared Understandings in a Physics Classroom." *International Journal of Science Education* 19 (1997): 209-228.
- Weinberg, Steven. "A Unified Physics by 2050?" *Scientific American* (Dec. 1999): 68-73.
- White, B.Y., and J.R. Frederiksen. "Inquiry, Modeling, and Metacognition: Making Science Accessible to All Students." *Cognition and Instruction* 16.1 (1998): 3-118.
- Wiggins, Grant. "What Is a Rubric? A Dialogue on Design and Use." In *Student Performance Assessment in the Era of Restructuring*. Ed. Robert E. Blum and Judith A. Arter. Alexandria, VA: ASCD Vi. 5, 1995.
- Williams, Robin. *The Non-Designer's Design Book: Design and Typographic Principles for the Visual Novice*. Berkeley, CA: Peachpit Press, 1994.
- Willis, Scott. *Interdisciplinary Learning: Movement to Link the Disciplines Gains Momentum, Curriculum Update*. Alexandria, VA: Association for Supervision and Curriculum Development, November 1992.
- Wood, D., J. Bruner, and G. Ross. "The Role of Tutoring in Problem Solving." *Journal of Child Psychology and Psychiatry* 17 (1976): 89-100.
- Zitzewitz, Paul W. *Physics: Principles and Problems*. New York, NY: Glencoe/McGraw-Hill, 2002.