



# Senior 3 Physics

A Foundation for  
Implementation

---

# ***SENIOR 3 PHYSICS***

*A Foundation for Implementation*

**2003**

Manitoba Education and Youth

---

---

## Manitoba Education and Youth Cataloguing in Publication Data

510           Senior 3 physics : a foundation  
                  for implementation

ISBN 0-7711-2489-9

1. Physics—Study and teaching (Secondary) —  
Manitoba. 2. Physics—Curricula. 3. Physics  
education—Science. I. Manitoba Dept. of  
Education and Youth.

Copyright © 2003, the Crown in Right of Manitoba as represented by the Minister of Education and Youth. Manitoba Education and Youth, School Programs Division, 1970 Ness Avenue, Winnipeg, Manitoba R3J 0Y9.

Every effort has been made to acknowledge original sources and to comply with copyright law. If cases are identified where this has not been done, please notify Manitoba Education and Youth. Errors or omissions will be corrected in a future edition. Sincere thanks to the authors and publishers who allowed their original material to be adapted or reproduced.

---

# ACKNOWLEDGEMENTS

Manitoba Education and Youth gratefully acknowledges the contributions of the following individuals in the development of *Senior 3 Physics (30S): A Foundation for Implementation*.

## Principal Writer

Don Metz, Ph.D.                      Education Program                      University of Winnipeg

## Physics Education and Curriculum Advisor

Prof. Arthur O. Stinner      Faculty of Education                      University of Manitoba

## Contributing Writers

Steven Boyko                      St. Boniface Diocesan H.S.                      Catholic Schools Commission  
 Heidi Holst                      Math/Science Lead Teacher                      Lord Selkirk S.D.  
 John Murray                      Science Consultant                      Manitoba Education and Youth

## Members of the Manitoba Development Team for *Senior 3 Physics: A Foundation for Implementation*

Jeff Anderson                      Collège Jeanne Sauvé                      Division scolaire Louis-Riel  
 Alphonse Bernard                      Collège Louis Riel                      Division scolaire franco-manitobaine  
  
 Steven Boyko                      St. Boniface Diocesan H.S.                      Catholic Schools Commission  
 Jason Braun                      John Taylor Collegiate                      St. James-Assiniboia S.D.  
 Elizabeth Kozoriz                      Daniel MacIntyre Collegiate                      Winnipeg S.D.  
 Gary Myden                      Hapnot Collegiate Institute                      Flin Flon S.D.  
 Barry Panas                      River East Collegiate                      River East-Transcona S.D.  
 Bryan Reimer                      Arthur Meighen Collegiate                      Portage la Prairie S.D.  
 Rodelyn Stoeber                      Institut collégial Vincent Massey                      Division scolaire Pembina Trails

## Graphics Design

Barry Panas                      River East Collegiate                      River East-Transcona S.D.

## Kindergarten to Senior 4 Science Steering Committee

Ron Banister                      Manitoba Teachers' Society                      Winnipeg S.D.  
 Sharon Burns                      Manitoba Association of Parent Councils  
 Randy Cielen                      Science Teachers' Association of Manitoba                      Transcona-Springfield S.D. (until September 2002)  
 Terry DeRoo                      Trades Department                      Assiniboine Community College (until September 2002)  
 David Graham                                           Red River College

Kay Harvey	Manitoba Association of School Trustees	Whiteshell S.D.
Ron Hildebrand	Manitoba Association of School Superintendents	River East-Transcona S.D.
Veronica Klassen	Eastwood Elementary School	Mystery Lake S.D.
Jan Pazdzierski	McIsaac School	Flin Flon S.D.
Rick Pokrant	Science Teachers' Association of Manitoba	River East-Transcona S.D. (since October 2002)
Dr. G. Gordon Robinson	Faculty of Science	University of Manitoba (until September 2002)
Rick Skarban	Councils for School Leadership	Mystery Lake S.D.
Deb Spelchak	Glenlawn Collegiate	Division scolaire Louis-Riel
Dr. Dawn L. Sutherland	Education Program	University of Winnipeg

**School Programs Division Staff**

Lee-Ila Bothe	Coordinator	Production Support Unit Program Development Branch
Diane Cooley	Project Manager	Curriculum Unit Program Development Branch
Lynn Harrison	Desktop Publisher	Production Support Unit Program Development Branch
Grant Moore	Publications Editor	Production Support Unit Program Development Branch
John Murray	Project Leader	Curriculum Unit Program Development Branch

**Bureau de l'éducation française Division Staff**

Jean-Vianney Auclair	Director	Bureau de l'éducation française
Daniele Dubois-Jacques	Consultant	Bureau de l'éducation française

# CONTENTS

## Acknowledgements *iii*

## Introduction 1

Background	1
Vision for Scientific Literacy	1
The Vision of <i>Senior 3 Physics: A Foundation for Implementation</i>	2
Goals for Canadian Science Education	2
Beliefs about Learning, Teaching, and Assessing Science	2
Changing Emphases in Science Education Content Delivery	3
Changing Emphases to Promote Inquiry	3

## Section 1: Manitoba Foundations for Scientific Literacy

The Five Foundations	3
Nature of Science and Technology	4
Science, Technology, Society, and the Environment (STSE)	6
Scientific and Technological Skills and Attitudes	9
Essential Science Knowledge	12
The Unifying Concepts	14
Kindergarten to Senior 2 Topic Chart	16

## Section 2: Implementation

The Senior Years Student and the Science Learning Environment	3
Characteristics of Senior 3 Learners	3
Effective Teaching in Physics: What the Research Says to Teachers	14
Unit Development in Physics	16
A View of Physics Education: Toward Modes of Representation	17
The Modes of Representation	18
The Importance of the Modes of Representation	21
Toward an Instructional Philosophy in Physics	23

## Section 3: Assessment in Senior 3 Physics

Characteristics of Effective Assessment	4
Types of Assessment	10
Assessment Strategies	11

## Section 4: Document Organization

- Guide to Reading Specific Learning Outcomes and Document Format 3
- Document Format 4
- Guide to Reading Specific Learning Outcomes 6
- Overview 7

## Topic 1: Waves

## Topic 2: The Nature of Light

## Topic 3: Mechanics

## Topic 4: Fields

## Appendices

### Appendix 1: Waves

- 1.1: Strobe Template 3
- 1.2: Concept Map for Wave Equation Variables 4
- 1.3: Superposition of Waves 5
- 1.4: Waves in One Dimension 7
- 1.5: Derivation of Snell's Law 11
- 1.6: Circular Wave Patterns 14
- 1.7: Interference Pattern from Two Point Sources 16
- 1.8: Moiré Patterns 17
- 1.9: Data Table for Speed of Sound 19
- 1.10 Sound Intensity Levels Table 20

### Appendix 2: The Nature of Light

- 2.1: Wave-Particle Model of Light—Models, Laws, and Theories 21
- 2.2: The Mystery Container 24
- 2.3: Astronomy with a Stick 26
- 2.4: Chart for Evaluating the Models of Light 27
- 2.5: Jupiter and Its Moon Io 28
- 2.6: Ole Christensen Rømer: The First Determination of the Finite Nature of the Speed of Light 29
- 2.7: Ole Rømer and the Determination of the Speed of Light 32
- 2.8: Why Were Eclipse Events at Jupiter Important to 17th-Century Science? 42
- 2.9: Becoming Familiar with Ionian Eclipses 43
- 2.10: Simulating Rømer's Eclipse Timings Using *Starry Night Backyard* 47
- 2.11: Contributions to the Determination of the Speed of Light 55

**Appendix 3: Mechanics**

- 3.1: Working with the Modes of Representation 57
- 3.2: A Vector Journey 59
- 3.3: Journal Entry on Vectors 61
- 3.4: A Vector Sampler 62
- 3.5: Analysis of Data Using *Microsoft Excel* 63
- 3.6: Describing Motion in Various Ways 66
- 3.7: Introducing Motion: Position, Time, Distance and Speed, Displacement, and Velocity 68
- 3.8: Motion: Interpreting Position-Time Graphs 78
- 3.9: Journal Entry: Kinematics (Position and Velocity) 84
- 3.10: Kinematics: Position, Velocity, and Acceleration Graphs 87
- 3.11: Kinematics and Graphing Skills Builder 89
- 3.12: Kinematics: Position, Velocity, and Acceleration Graphs, and Their Equations 91
- 3.13: Kinematics Sampler: Graphs, Equations, and Problem Solving 93
- 3.14: Kinematics Graphs Transformation Organizer 98
- 3.15: Journal Entry: Dynamics and Diagrams 99
- 3.16: Free-Body Diagrams: Linear Motion 101
- 3.17: Free-Body Diagrams 2: Linear Motion 102

**Appendix 4: Fields**

- 4.1: Vertical Motion at the Earth's Surface 103
- 4.2: Journal Entry: Gravitational Fields 105
- 4.3: Student Sampler: Magnetic Fields 106
- 4.4: Student Article Analysis—Scientific Fraud? 108
- 4.5: William Gilbert and the Earth's Magnetic Field 114

**Appendix 5: Developing Assessment Rubrics in Science**

- The Nature, Purpose, and Sources of Assessment Rubrics for Science 121
- Developing Rubrics in Collaboration with Students 124



**Appendix 6: Assessment Rubrics**

Rubric for the Assessment of Class Presentations	129
Rubric for the Assessment of a Research Project	130
Rubric for the Assessment of a Decision-Making Process Activity	131
Lab Report Assessment	133
Observation Checklist—Scientific Inquiry: Conducting a Fair Test	134
Rubric for Student Presentation	135
Rubric for Research Skills	136

**Appendix 7: General Learning Outcomes 137**

**Bibliography**

---

# INTRODUCTION

---

## Background

*Senior 3 Physics: A Foundation for Implementation (2003)* presents student learning outcomes for Senior 3 Physics. These learning outcomes are the same for students in English, French Immersion, Français, and Senior Years Technology Education programs, and result from a partnership involving two divisions of Manitoba Education and Youth: School Programs Division and Bureau de l'éducation française. Manitoba's science student learning outcomes for Senior 3 Physics are based, in part, on those found within the *Common Framework of Science Learning Outcomes K to 12* (Council of Ministers of Education, Canada) and on those developed as components of the 1998 Transitional Curricula. The former, commonly referred to as the *Pan-Canadian Science Framework*, was initiated under the Pan-Canadian Protocol for Collaboration on School Curriculum (1997), and was developed by educators from Manitoba, Saskatchewan, Alberta, British Columbia, the Northwest Territories, the Yukon Territory, Ontario, and the Atlantic provinces.

*Senior 3 Physics: A Foundation for Implementation* provides the basis for learning, teaching, and assessing physics in Manitoba. It also serves as a starting point for future development of curriculum support documents, related teacher support materials, learning resources, assessment tools, and professional learning for teachers. This document also complements the *Pan-Canadian Science Framework* by providing support for its implementation, including suggestions for instruction and assessment.

## Vision for Scientific Literacy

Global interdependence; rapid scientific and technological innovation; the need for a sustainable environment, economy, and society; and the pervasiveness of science and technology in daily life reinforce the importance of scientific literacy. Scientifically literate individuals can more effectively interpret information, solve problems, make informed decisions, accommodate change, and achieve new understandings. Science education makes possible the development of the foundations necessary to develop a functional **scientific literacy**, and assists in building stronger futures for Canada's young people.

The *Pan-Canadian Science Framework* and *Senior 3 Physics: A Foundation for Implementation* are designed to support and promote an attainable and realistic vision for scientific literacy. Student learning outcomes are concise descriptions of the knowledge and skills (and attitudes) that students are expected to learn in a course or grade level in a subject area (Manitoba Education and Training, *A Foundation for Excellence*, 1995).

### **The Vision of Senior 3 Physics: A Foundation for Implementation**

The *Pan-Canadian Science Framework* was guided by the vision that all Canadian students, irrespective of gender or cultural background, will have an opportunity to develop their own individual approaches to scientific literacy. Scientific literacy is an ever-evolving combination of the science-related attitudes, skills, and knowledge students need to develop inquiry, problem-solving, and decision-making abilities to become lifelong learners. No less important, scientific literacy should maintain in students a sense of curiosity, wonder, awe, and abiding respect for the world around them.

Diverse learning experiences based on the *Pan-Canadian Science Framework* will provide students with many opportunities to explore, analyze, evaluate, synthesize, appreciate, and understand the interrelationships among science, technology, society, and the environment that will affect their personal lives, careers, and their future (Council of Ministers of Education, Canada, 1997).

### **Goals for Canadian Science Education**

Several goals promoting the achievement of scientific literacy within Canadian science education were developed as part of the *Pan-Canadian Science Framework*. These goals are addressed through the Manitoba science curricula. It is hoped that science education will:

- encourage students at all levels to develop a rational sense of wonder and curiosity about scientific and technological endeavours;
- enable students to use science and technology to acquire new knowledge and solve problems, so they may improve the quality of their own lives and the lives of others;
- prepare students to critically address science-related societal, economic, ethical, and environmental issues;
- provide students with a proficiency in science that creates opportunities for them to pursue progressively higher levels of advanced study, preparing them for science-related occupations, and engaging them in science-related activities appropriate to their interests and abilities; and
- develop in students of varying aptitudes and interests a knowledge of the wide variety of careers related to science, technology, and support for the natural and human environments.

### **Beliefs about Learning, Teaching, and Assessing Science**

To promote a rational, achievable approach to developing scientific literacy among future citizens, it is crucial to recognize how students learn, how science can best be taught, and how learning can be assessed. Students are curious, active learners who have individual interests, abilities, and needs. They come to school with various personal and cultural experiences and prior knowledge that generate a range of attitudes and beliefs about science and life, and connections between these realms.

Students learn most effectively—in a Piagetian sense—when their study of science is rooted in concrete learning experiences related to a particular context or situation, and applied to their world of experiences where appropriate. Ideas and understandings that students develop should be progressively extended and reconstructed as students grow in their experiences and in their ability to conceptualize more deeply. Learning involves the process of linking newly constructed understandings *with* prior knowledge, and then adding new contexts and experiences to current understandings. It is increasingly important that physics educators draw professional attention to how fundamental research in learning theory will affect their efforts in the science classroom.

#### Changing Emphases in Science Education Content Delivery\*

The *National Science Education Standards* envision change throughout the system. The science content standards [or student learning outcomes] encompass the following changes in emphases:

##### LESS EMPHASIS ON

Knowing scientific facts and information

Studying subject matter disciplines (physical, life, earth sciences) for their own sake

Separating science knowledge and science process

Covering many science topics

Implementing inquiry as a set of processes

##### MORE EMPHASIS ON

Understanding scientific concepts and developing abilities of inquiry

Learning subject matter disciplines in the context of inquiry, technology, science in personal and social perspectives, and history and nature of science

Integrating all aspects of science content

Studying a few fundamental science concepts

Implementing inquiry as instructional strategies, abilities, and ideas to be learned

#### Changing Emphases to Promote Inquiry

##### LESS EMPHASIS ON

Activities that demonstrate and verify science content

Investigations confined to one class period

Process skills out of context

Individual process skills such as observation or inference

Getting an answer

Science as exploration and experiment

Providing answers to questions about science content

Individuals and groups of students analyzing and synthesizing data without defending a conclusion

Doing a few investigations in order to leave time to cover large amounts of content

Concluding inquiries with the result of the experiment

Management of materials and equipment

Private communication of student ideas and conclusions to teacher

##### MORE EMPHASIS ON

Activities that investigate and analyze science questions

Investigations over extended periods of time

Process skills in context

Using multiple process skills—manipulation, cognitive, procedural

Using evidence and strategies for developing or revising an explanation

Science as argument and explanation

Communicating science explanations

Groups of students often analyzing and synthesizing data after defending conclusions

Doing more investigations in order to develop understanding, ability, values of inquiry, and knowledge of science content

Applying the results of experiments to scientific arguments and explanations

Management of ideas and information

Public communication of student ideas and work to classmates

\* Reprinted with permission from *National Science Education Standards*. Copyright © 1996 by the National Academy of Sciences. Courtesy of the National Academies Press. Washington, DC.

Development of increased scientific literacy is supported by instructional environments that engage students in the following:

- **SCIENCE INQUIRY:** Students are encouraged to converse, ask penetrating questions, and then seek to explore their own constructed explanations alongside scientific explanations through guided research, writing, and planned investigations.
- **PROBLEM SOLVING:** Students apply their acquired expertise and knowledge in novel, oftentimes unforeseeable, ways.
- **DECISION MAKING:** As students identify rich, large-context problems, questions, or issues related to the human and robotic exploration of the universe, they pursue new knowledge that will assist them in making informed, rational, defensible decisions that are rooted in the societal and humanistic domains within which science practice operates.
- **THE NATURE OF SCIENCE:** Students appreciate and value the understanding that science operates with the consent of personal, social, political, environmental, and multicultural orientations of the global society. Moreover, there are consequences when science circumvents its responsibilities among these societal contexts.
- **SCIENCE-RELATED SKILLS:** Examples of these skills include initiating, planning, performing, recording, analyzing, interpreting, communicating, and team building. All these skills have central importance in learning the dimensions of science. It is important that science students of today not be taught the myth of a single, specifiable “scientific method” that leads to a superior “truth” about the material world. If there is indeed an objective “reality,” philosophers of science often agree that it may be difficult to define, or perhaps be unknowable. Nevertheless, the methods of science systematically permit new knowledge domains to be constructed, and that knowledge is often robust and durable.
- **SCIENCE CONTENT KNOWLEDGE:** Transmission of science content is no longer considered to be the primary outcome of science teaching. In addition, science knowledge is actively constructed from existing and emerging personal and social knowledge. Creative, integrative, and interdisciplinary linkages should be balanced with the traditional “disciplinary focus” of teaching and learning in physics. Unifying concepts among traditional, bounded, restricted disciplines now give way to, and add form and substance to, new views of exploration among the sciences that are holistic and interdisciplinary.

It is through these processes that students discover the significance of science in their lives and come to appreciate the interrelatedness of science, technology, society, and the environment. Each of these processes can be a starting point for science learning, and may encompass the exploration of new ideas, the development of specific investigations, and the application of ideas that are learned.

To achieve the vision of a scientific literacy for all according to personal interests and inclinations, students could become increasingly more engaged in the planning, development, and evaluation of their own learning experiences. They should have the opportunity to work cooperatively with other students, to initiate investigations, to communicate their findings, and to complete projects that demonstrate their learning in a personal, though peer-reviewed, manner. At the beginning of instructional design, teachers and students should identify expected student learning outcomes and establish performance criteria. It is important that these criteria correspond with provincial student learning outcomes. This communication between students and teachers helps to identify clearly what needs to be accomplished, thereby assisting in the learning process (see the rubrics in Appendix 5).

When students are aware of expected outcomes, they will be more focussed on their learning, and may be more likely to assess their own progress. Furthermore, they can participate in creating appropriate assessment and evaluation criteria. Assessment methods must be valid, reliable, and fair to students.

## NOTES

---

## ***SECTION 1***

The Five Foundations	3
Nature of Science and Technology	4
Science, Technology, Society, and the Environment (STSE)	6
Scientific and Technological Skills and Attitudes	9
Essential Science Knowledge	12
The Unifying Concepts	14
Kindergarten to Senior 2 Topic Chart	16

---



# MANITOBA FOUNDATIONS FOR SCIENTIFIC LITERACY

## The Five Foundations

To develop scientifically literate students, Manitoba science curricula are built upon five foundations for scientific literacy (Figure 1) that have been adapted from the *Pan-Canadian Science Framework* to address the needs of Manitoba students. These include:

- Nature of Science and Technology
- Science, Technology, Society, and the Environment (STSE)
- Scientific and Technological Skills and Attitudes
- Essential Science Knowledge
- Unifying Concepts

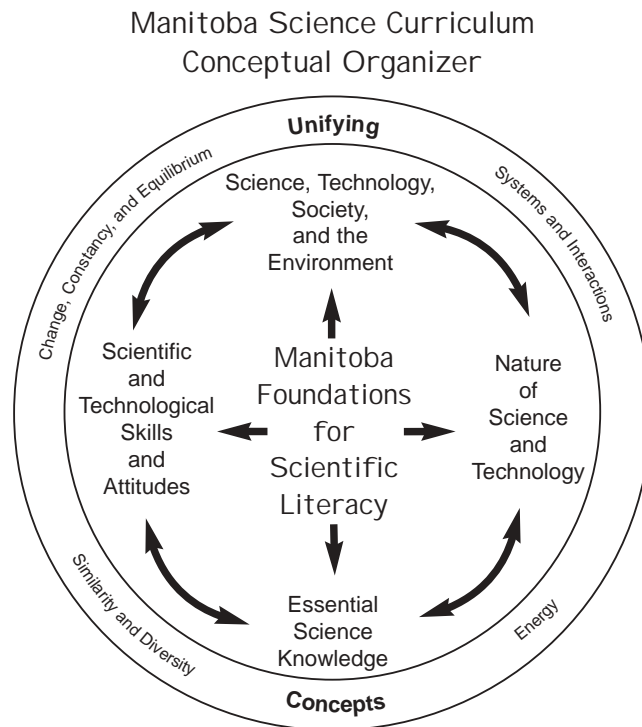

**Figure 1:** Manitoba Science Curriculum Conceptual Organizer

In the following pages, each foundation is described, representing the goals of science learning in Kindergarten to Senior 4. These foundations led to the development of the general learning outcomes contained in *Senior 3 Physics: A Foundation for Implementation* (2003).

## Nature of Science and Technology

Students learn that science and technology are creative human activities with long histories in all cultures. Science is a way of learning about the universe. This learning stems from curiosity, creativity, imagination, intuition, exploration, observation, replication of experiments, interpretation of evidence, and debate over that evidence and its interpretations. Scientific activity involves predicting, interpreting, and explaining natural and human-made phenomena. Many historians, sociologists, and philosophers of science presently argue that there is no definable, set procedure for conducting a scientific investigation. Rather, they see science as driven by a combination of theoretical concerns, knowledge, experiments, and processes anchored in the physical world.

Producing science knowledge is an intrinsically collective endeavour. There is no such thing as stand-alone science done in isolation. Scientists submit models and solutions for the assessment of their peers, who judge their logical, rational and experimental soundness through reference to the body of existing knowledge and modes of representation (Larochelle and Désautels, 1992).

Scientific theories are being tested, modified, and refined continually as new knowledge and theories supersede existing knowledge bases. Scientific debate, both on new observations and on hypotheses that challenge accepted knowledge, involves many participants with diverse backgrounds. This highly complex interplay, which has occurred throughout history, is animated by theoretical discussions; experimentation; social, cultural, economic, and political influences; personal biases; and the need for peer recognition and acceptance. Students will realize that while some of our understandings about how the world works are due to revolutionary scientific developments, many of our understandings result from the steady and gradual accumulation of knowledge. History demonstrates, however, that great advances in scientific thought have completely uprooted certain disciplines, transplanting practitioners and theoreticians alike into an entirely new set of guiding assumptions. Such *scientific revolutions*, as discussed by Thomas S. Kuhn in his influential *The Structure of Scientific Revolutions* (Kuhn, 1962), constitute exemplars that can energize the science teaching enterprise—particularly in physics education.

Technology results mainly from proposing solutions to problems arising from human attempts to adapt to the external environment. Technology may be regarded as "... a tool or machine; a process, system, environment, epistemology, and ethic; the systematic application of knowledge, materials, tools, and skills to extend human capabilities..." (Manitoba Education and Training, *Technology As a Foundation Skill Area: A Journey Toward Information Technology Literacy*, 1998). "Technology" refers to much more than the knowledge and skills related to computers and their applications. Technology is based on the knowledge of concepts and skills from other disciplines (including science), and is the application of this knowledge to meet

an identified need or to solve a problem using materials, energy, and tools (including computers). Technology also has an influence on processes and systems, on society, and on the ways people think, perceive, and define their world.

*Senior 3 Physics* is designed to emphasize both the distinctions and relationships between science and technology. Figure 2 illustrates how science and technology differ in purpose, procedure, and product, while at the same time relate to each other.

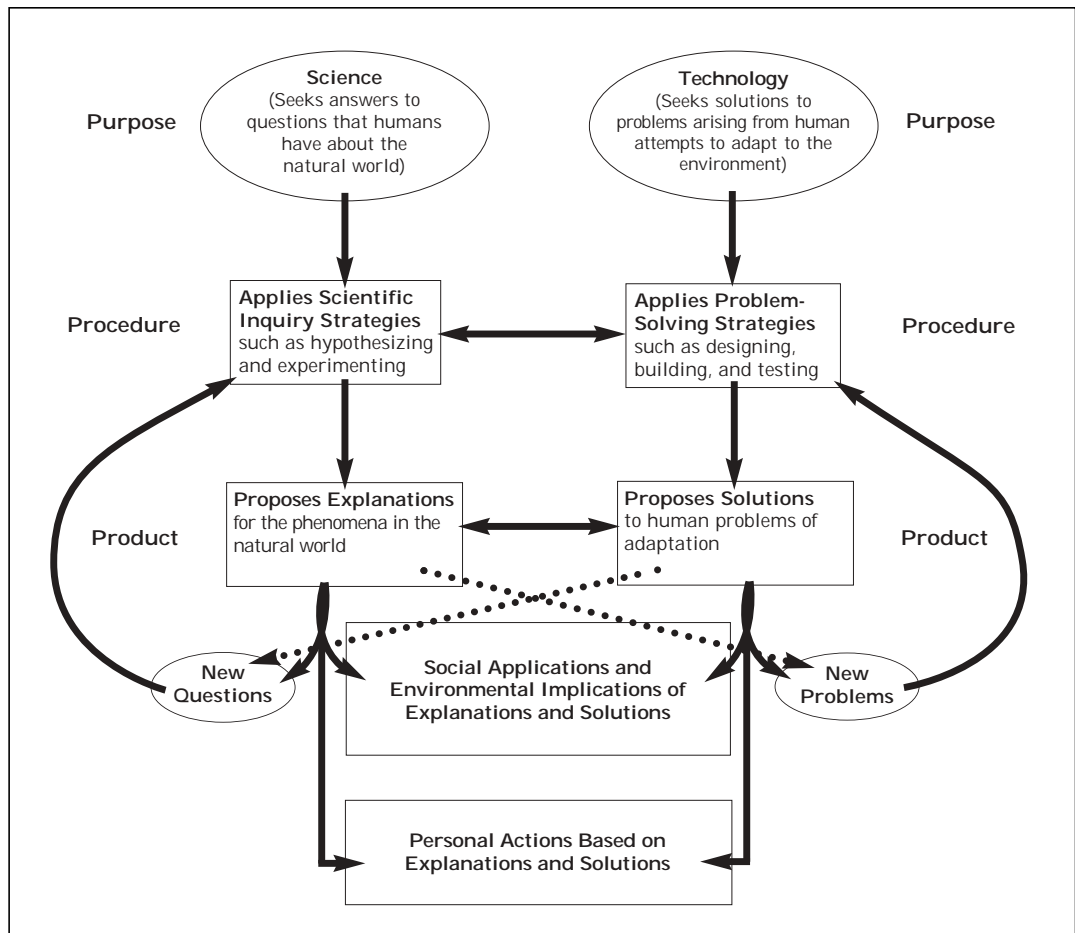

Figure 2: Science and Technology: Their Nature and Interrelationships\*

\* Adapted from Bybee, Rodger W. et al., *Science and Technology Education for the Elementary Years: Frameworks for Curriculum and Instruction*. Copyright © 1989 The NETWORK Inc.

The following General Learning Outcomes (GLOs) have been developed to further define expectations related to this foundation area (for a complete listing of Science GLOs, see Appendix 7).

### **Nature of Science and Technology General Learning Outcomes**

As a result of their Senior Years science education, students will

- A1. recognize both the power and limitations of science as a way of answering questions about the world and explaining natural phenomena
- A2. recognize that scientific knowledge is based on evidence, models, and explanations, and evolves as new evidence appears and new conceptualizations develop
- A3. distinguish critically between science and technology in terms of their respective contexts, goals, methods, products, and values
- A4. identify and appreciate contributions made by women and men from many societies and cultural backgrounds that have increased our understanding of the world and brought about technological innovations
- A5. recognize that science and technology interact with and advance one another

### **Science, Technology, Society, and the Environment (STSE)**

Understanding the complex interrelationships among STSE is an essential component of fostering increased scientific literacy. By studying the historical context, students come to appreciate ways in which cultural and intellectual traditions have influenced the questions and methodologies of science, and how science, in turn, has influenced the wider world of ideas.

Today, most scientists work in industry, where projects are more often driven by societal and environmental needs than by pure research. Many technological solutions have evoked complex social and environmental issues. Students recognize the potential of scientific literacy to inform and empower decision making of individuals, communities, and society as a whole.

Scientific knowledge is necessary, but not sufficient, for understanding the relationships among science, technology, society, and the environment. To understand these relationships fully, it is essential that students consider the values related to science, technology, society, and the environment.

As a component of achieving scientific literacy, students must also develop an appreciation for the importance of sustainable development. Sustainable development is a decision-making model that considers the needs of both present and future generations, and integrates and balances the impact of economic activities, the environment, and the health and well-being of the community (see Figure 3). Educators are encouraged to consult *Education for a Sustainable Future* (Manitoba Education and Training, 2000), which outlines ways of incorporating precepts, principles, and practices to foster appropriate

learning environments that would help direct students toward a sustainable future. The document can be accessed online at:

<<http://www.edu.gov.mb.ca/ks4/docs/support/future/sustainededucation.pdf>>.

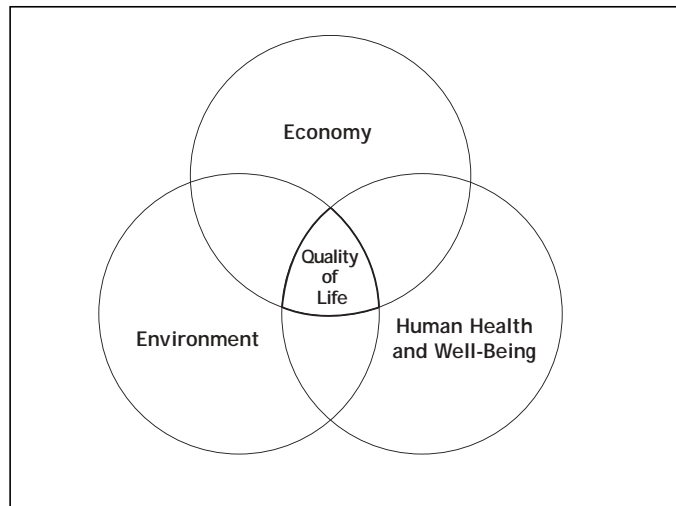

Figure 3: Sustainable Development

**Sustainable human health and well-being** is characterized by people coexisting harmoniously within local, national, and global communities, and with nature. A sustainable society is one that is physically, psychologically, spiritually, and socially healthy. The well-being of individuals, families, and communities is of considerable importance.

A **sustainable environment** is one in which the life-sustaining processes and natural resources of the Earth are conserved and regenerated.

A **sustainable economy** is one that provides equitable access to resources and opportunities. It is characterized by development decisions, policies, and practices that respect cultural realities and differences, and do not exhaust the Earth's resources. A sustainable economy is evident when decisions, policies, and practices are carried out to minimize their impact on the Earth's resources and to maximize the regeneration of the natural environment.

Decisions or changes related to any one of the three components—human health and well-being, the environment, or the economy—have a significant impact on the other two components and, consequently, on our quality of life. Decision making must take into account all three components to ensure an equitable, reasonable, and sustainable quality of life for all.

### **Sustainable Development, Social Responsibility, and Equity**

Sustainable development supports principles of social responsibility and equity. Williams (1994) believes that the concept of equity is essential to the attainment of sustainability. This includes equity among nations, within nations, between humans and other species, as well as between present and future generations.

Sustainable development is, at the same time, a decision-making process, a way of thinking, a philosophy, and an ethic. Compromise is an important idea that underlies the decision-making process within a sustainable development approach. In order to achieve the necessary balance among human health and well-being, the environment, and the economy, some compromises will be necessary.

There can be no greater contribution or more essential element to long-term environmental strategies leading to sustainable development that respects the environment ... than the education of future generations in matters relating to the environment (UNESCO, 1988).

Public awareness and understanding of the concept of sustainable development and its practices are essential. If we are to change our way of life we must equip present and future generations with the knowledge and training to put sustainable development into effect (Sustainability Manitoba, 1994).

As students advance from grade to grade, they identify STSE interrelationships and apply decision-making skills in increasingly demanding contexts, as outlined in the following ways:

- **complexity of understanding**—from simple, concrete ideas to abstract ideas; from limited knowledge of science to more in-depth and broader knowledge of science and the world;
- **applications in context**—from contexts that are local and personal to those that are societal and global;
- **consideration of variables and perspectives**—from one or two that are simple to many that are complex;
- **critical judgement**—from simple right or wrong assessments to complex evaluations; and
- **decision making**—from decisions based on limited knowledge, made with the teacher's guidance, to decisions based on extensive research that are made independently and involve personal judgement.

This foundation area has led to the development of the following GLOs in *Senior 3 Physics: A Foundation for Implementation*.

### **Science, Technology, Society, and the Environment (STSE) General Learning Outcomes**

As a result of their Senior Years science education, students will

- B1. describe scientific and technological developments—past and present—and appreciate their impact on individuals, societies, and the environment, both locally and globally
- B2. recognize that scientific and technological endeavours have been and continue to be influenced by human needs and the societal context of the time

- B3. identify the factors that affect health, and explain the relationships among personal habits, lifestyle choices, and human health, both individual and social
- B4. demonstrate a knowledge of and personal consideration for a range of possible science- and technology-related interests, hobbies, and careers
- B5. identify and demonstrate actions that promote a sustainable environment, society, and economy, both locally and globally

### Scientific and Technological Skills and Attitudes

A science education that strives for developing scientific literacy must engage students in answering questions, solving problems, and making decisions. These processes are referred to as scientific inquiry, technological problem solving (the design process), and decision making (see Figure 4). While the skills and attitudes involved in these processes are not unique to science, they play an important role in the development of scientific understandings and in the application of science and technology to new situations.

	Scientific Inquiry	Technological Problem Solving (Design Process)	Decision Making
<b>Purpose:</b>	Satisfying curiosity about events and phenomena in the natural world.	Coping with everyday life, practices, and human needs.	Identifying different views or perspectives based on varying information.
<b>Procedure:</b>	What do we know? What do we want to know?	How can we do it? Will it work?	What are the alternatives or consequences? Which choice is best at this time?
<b>Product:</b>	Knowledge about events and phenomena in the natural world.	An effective and efficient way to accomplish a task or meet a need.	A defensible decision in a particular circumstance.

	Scientific Question	Technological Problem	STSE Issue
<b>Example:</b>	Why does my coffee cool so quickly?  <i>An Answer:</i> Heat energy is transferred by conduction, convection, and radiation to the surrounding environment.	How can I keep my coffee hot?  <i>A Solution:</i> A foam cup will keep liquids warm for a long time. So will an insulated cup.	Should we use foam cups or ceramic mugs for our meeting?  <i>A Decision:</i> Since we must use disposable cups for the meeting, a biodegradable type will be chosen.

Figure 4: Processes for Science Education\*

\*Adapted with permission of the Minister of Education, Province of Alberta, Canada, 1999.

Each of these **processes** is described on the following page. **Attitudes**, an important element of each process, are also examined, and are treated as indicators along the pathway of student achievement. Hence, attitudes are to be modelled by teachers and students, but are not formally assessed in the same manner as other specific learning outcomes.

### **Scientific Inquiry**

Scientific inquiry is a way of learning about the universe. It involves posing questions and searching for explanations of phenomena. Although no single “scientific method” exists, students require certain skills to participate in science-related experiences using a variety of appropriate methods.

Skills such as questioning, observing, inferring, predicting, measuring, hypothesizing, classifying, designing experiments, and collecting, analyzing, and interpreting data are fundamental to scientific inquiry—as are attitudes such as curiosity, skepticism, and creativity. These skills are often represented as a cycle. This cycle involves posing questions, generating possible explanations, and collecting and analyzing evidence to determine which of these explanations is most useful and accurate in accounting for the phenomena under investigation. New questions may arise to reignite the cycle. It must be noted, however, that many scientific inquiries (past and present) do not necessarily follow a set sequence of steps, nor do they always start at the “beginning” of the cycle; scientists can be creative and responsive to scientific challenges as they arise.

### **Technological Problem Solving**

Technological problem solving seeks solutions to problems arising from human attempts to adapt to or change the environment. In Kindergarten to Grade 8 science, students have been developing these skills using a cycle of steps called the design process. This design process includes the proposing, creating, and testing of prototypes, products, and techniques in an attempt to reach an optimal solution to a given problem. Feedback and evaluation are built into this cycle. In Senior Years science, these technological problem-solving skills are incorporated into a decision-making process.

### **STSE Issues and Decision Making**

Students, as individuals and global citizens, are required to make decisions. Increasingly, the types of issues they face demand an ability to apply scientific and technological knowledge, processes, and products to the decisions they make related to STSE. The decision-making process involves a series of steps, which may include:

- clarification of the issue;
- critical evaluation of all available research;
- generating possible courses of action;
- making a thoughtful decision;
- examining the impact of the decision; and
- reflecting on the process.



Students should be actively involved in decision-making situations as they progress through their science education. Not only are decision-making situations important in their own right, but they also provide a relevant context for engaging in scientific inquiry, problem solving, and the study of STSE relationships (see Figure 5).

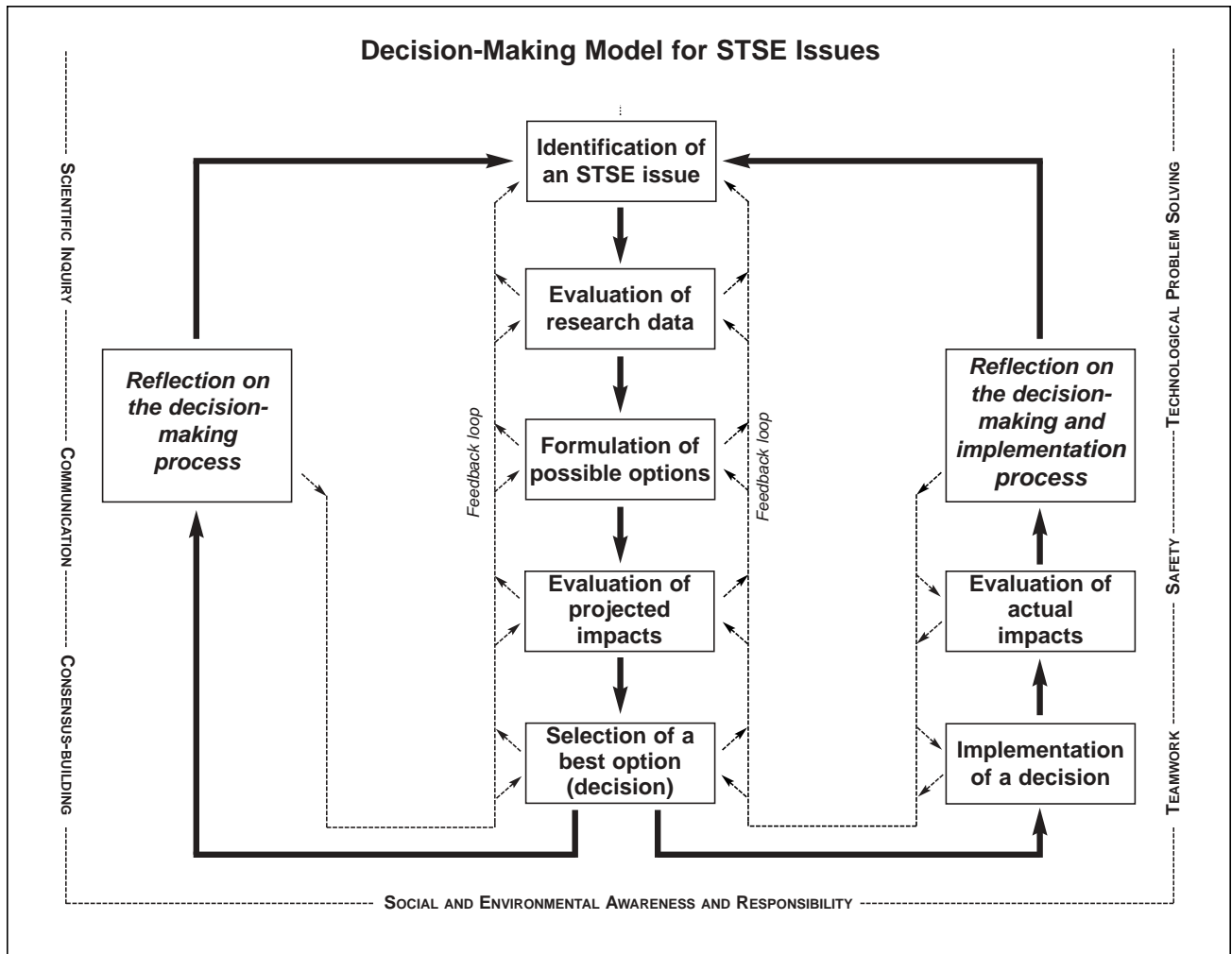

Figure 5: Decision-Making Model for STSE Issues

### Attitudes

Attitudes refer to generalized aspects of behaviour that are modelled for students. Attitudes are not acquired in the same way as skills and knowledge. They cannot be observed at any particular moment, but are evidenced by regular, unprompted manifestations over time. Development of attitudes is a lifelong process that involves the home, the school, the community, and society at large. The development of positive attitudes plays an important role in students' growth, affecting their intellectual development and creating a readiness for responsible application of what they learn.

The following **General Learning Outcomes** (GLOs) have been developed to further define expectations related to this foundation area, and provide the basis for the set of Skills and Attitudes that are identified as unique to Senior 3 Physics.

### **Scientific and Technological Skills and Attitudes General Learning Outcomes**

As a result of their Senior Years science education, students will

- C1. recognize safety symbols and practices related to scientific and technological activities and to their daily lives, and apply this knowledge in appropriate situations
- C2. demonstrate appropriate scientific inquiry skills when seeking answers to questions
- C3. demonstrate appropriate problem-solving skills when seeking solutions to technological challenges
- C4. demonstrate appropriate critical thinking and decision-making skills when choosing a course of action based on scientific and technological information
- C5. demonstrate curiosity, skepticism, creativity, open-mindedness, accuracy, precision, honesty, and persistence, and appreciate their importance as scientific and technological habits of mind
- C6. employ effective communication skills and use information technology to gather and share scientific and technological ideas and data
- C7. work cooperatively and value the ideas and contributions of others while carrying out scientific and technological activities
- C8. evaluate, from a scientific perspective, information and ideas encountered during investigations and in daily life

### **Essential Science Knowledge**

The subject matter of science includes theories, models, concepts, and principles that are essential to an understanding of life science, physical science, and Earth and space science. Content is a vehicle for essential learnings (Drake, 1993), and it will be increasingly important for students of physics to make interdisciplinary connections among the following.

**LIFE SCIENCES:** This involves the study of the growth and interactions of life forms within their environment in ways that reflect their uniqueness, diversity, genetic continuity, and changing nature. Life science includes the study of organisms (including humans and cells), ecosystems, biodiversity, biochemistry, and biotechnology.

**PHYSICAL SCIENCES:** Primarily associated with chemistry and physics, the physical sciences deal with matter, energy, and forces. Matter has structure, and interactions exist among its components. Energy links matter to gravitational, electromagnetic, and nuclear forces of the universe. The laws of conservation of mass and energy, momentum, and charge are addressed by physical science.

**GEOSCIENCES AND THE SPACE SCIENCES:** These studies provide students with local, global, and universal perspectives. Earth exhibits form, structure, and patterns of change, as does our surrounding solar system and the physical universe beyond. Earth and space science includes fields of study such as geology, hydrology, meteorology, and astronomy.

The following GLOs have been developed to further define expectations related to this foundation area.

### **Essential Science Knowledge General Learning Outcomes**

As a result of their Senior Years science education, students will

- D1. understand essential life structures and processes pertaining to a wide variety of organisms, including humans
- D2. understand various biotic and abiotic components of ecosystems, as well as their interaction and interdependence within ecosystems and within the biosphere as a whole
- D3. understand the properties and structures of matter as well as various common manifestations and applications of the actions and interactions of matter
- D4. understand how stability, motion, forces, and energy transfers and transformations play a role in a wide range of natural and constructed contexts
- D5. understand the composition of the Earth's atmosphere, hydrosphere, and lithosphere, as well as the processes involved within and among them
- D6. understand the composition of the universe, the interactions within it, and the implications of humankind's continued attempts to understand and explore it

## **The Unifying Concepts**

An effective way to create linkages within and among science disciplines is to use unifying concepts—the key ideas that underlie and integrate all science knowledge and extend into areas such as mathematics and social studies. Unifying concepts help students construct a more holistic, systems-related understanding of science and its role in society.

The following four unifying concepts were used in the development of *Senior 3 Physics: A Foundation for Implementation*.

### **Similarity and Diversity**

The concepts of similarity and diversity provide tools for organizing our experiences with the world. Beginning with informal experiences, students learn to recognize attributes of materials, organisms, and events that help to make useful distinctions between and among them. Over time, students adopt accepted procedures and protocols for describing and classifying objects, organisms, and events they encounter, thus enabling them to share ideas with others and to reflect on their own experiences.

### **Systems and Interactions**

An important part of understanding and interpreting the world is the ability to think about the whole in terms of its parts and, alternately, about parts in terms of how they relate to one another and to the whole. A system is a collection of components that interact with one another so that the overall effect is often different from that of the individual parts, even when these are considered together. Students will study both natural and technological systems.

### **Change, Constancy, and Equilibrium**

The concepts of constancy and change underlie most understandings of the natural and technological world. Through observations, students learn that some characteristics of living things, materials, and systems remain constant over time, whereas others change. Through formal and informal studies, students develop an understanding of the processes and conditions in which change, constancy, and equilibrium take place.

### **Energy**

The concept of energy provides a conceptual understanding that brings together many aspects of natural phenomena, materials, and the processes of change. Energy, whether transmitted or transformed, is the driving force of both movement and change. Students learn to describe energy in terms of its effects and, over time, develop a concept of energy as something inherent within the interactions of materials, the processes of life, and the functions of systems.

The following GLOs have been developed to further define expectations related to this foundation area.

**Unifying Concepts General Learning Outcomes**

As a result of their Senior Years science education, students will

- E1. describe and appreciate the similarity and diversity of forms, functions, and patterns within the natural and constructed world
- E2. describe and appreciate how the natural and constructed world is made up of systems and how interactions take place within and among these systems
- E3. recognize that characteristics of materials and systems can remain constant or change over time, and describe the conditions and processes involved
- E4. recognize that energy, whether transmitted or transformed, is the driving force of both movement and change, and is inherent within materials and in the interactions among them

## Kindergarten to Senior 2 Topic Chart

The following table provides a quick reference to the different thematic clusters from Kindergarten to Senior 2. This allows teachers to examine, at a glance, students' previous exposure to scientific knowledge in different areas.

	Cluster 0	Cluster 1	Cluster 2	Cluster 3	Cluster 4
Kindergarten	<b>Overall Skills and Attitudes</b>	Trees	Colours	Paper	—
Grade 1		Characteristics and Needs of Living Things	The Senses	Characteristics of Objects and Materials	Daily and Seasonal Changes
Grade 2		Growth and Changes in Animals	Properties of Solids, Liquids, and Gases	Position and Motion	Air and Water in the Environment
Grade 3		Growth and Changes in Plants	Materials and Structures	Forces that Attract or Repel	Soils in the Environment
Grade 4		Habitats and Communities	Light	Sound	Rocks, Minerals, and Erosion
Grade 5		Maintaining a Healthy Body	Properties of and Changes in Substances	Forces and Simple Machines	Weather
Grade 6		Diversity of Living Things	Flight	Electricity	Exploring the Solar System
Grade 7		Interactions within Ecosystems	Particle Theory of Matter	Forces and Structures	Earth's Crust
Grade 8		Cells and Systems	Optics	Fluids	Water Systems
Senior 1		Reproduction	Atoms and Elements	Nature of Electricity	Exploring the Universe
Senior 2		Dynamics of Ecosystems	Chemistry in Action	In Motion	Weather Dynamics

**Figure 6:** Kindergarten to Senior 2 Topic Chart

---

## **SECTION 2**

The Senior Years Student and the Science Learning Environment	3
Characteristics of Senior 3 Learners	3
Effective Teaching in Physics: What the Research Says to Teachers	14
Unit Development in Physics	16
A View of Physics Education: Toward Modes of Representation	17
The Modes of Representation	18
The Importance of the Modes of Representation	21
Toward an Instructional Philosophy in Physics	23

---

## IMPLEMENTATION

### **The Senior Years Student and the Science Learning Environment**

Each year, teachers are called upon to make a myriad of decisions regarding course content, learning materials and resources, and instructional and assessment methods. Successful learning is more likely to occur if these decisions are informed by teachers' understanding of their students and the ways they learn.

Teachers seeking to learn about their students need to be knowledgeable in various areas, including the following:

- **How people learn:** In recent decades, cognitive psychology, brain-imaging technology, and multiple intelligences theory have transformed our understanding of learning. Ongoing professional development is important to teachers as they seek to update their knowledge of the processes of learning.
- **The ways in which student populations are changing:** The students whom teachers encounter today are different in many respects from students a generation ago. Students are more likely to be living with a single parent or stepfamily. More have part-time jobs. Students are more sophisticated in their knowledge and use of information technology, and much of their understanding of the world comes from television. Classrooms are more likely to be ethnically diverse.
- **The developmental characteristics of Senior 3 students:** The characteristics of adolescent learners have many implications for teachers.
- **The unique qualities of each student:** Family relationships, academic and life experiences, personality, interests, learning approaches, socio-economic status, and rate of development all influence a student's ability to learn. Teachers can gain an understanding of the unique qualities of each student only through daily interaction, observation, and assessment.

### **Characteristics of Senior 3 Learners**

For many students, Senior 3 is a stable and productive year. Many Senior 3 students have developed a degree of security within their peer group and a sense of belonging in school. They show increasing maturity in dealing with the freedoms and responsibilities of late adolescence: romantic relationships, part-time jobs, a driver's licence. In Senior 3, most students have a great deal of energy and a growing capacity for abstract and critical thinking. Many are prepared to express themselves with confidence and to take creative and intellectual risks. The stresses and preoccupations of preparing for graduation, post-secondary education, or full-time jobs are still a year away. For many students, Senior 3 may be the most profitable academic year of the Senior Years.



Although many Senior 3 students handle their new responsibilities and the demands on their time with ease, others experience difficulty. External interests may seem more important than school. Because of their increased autonomy, students who previously had problems managing their behaviour at school may now express their difficulties through poor attendance, alcohol and drug use, or other behaviours that place them at risk.

Students struggling to control their lives and circumstances may make choices that seem to teachers to be contrary to their best interests. Communication with the home and awareness of what their students are experiencing outside school continue to be important for Senior 3 teachers. Although the developmental variance evident in Grade 6 through Senior 2 has narrowed, students in Senior 3 can still change a great deal in the course of one year or even one semester. Senior 3 teachers need to be sensitive to the dynamic classroom atmosphere and recognize when shifts in interests, capabilities, and needs are occurring, so they can adjust learning experiences for their students.

The chart on the following pages identifies some common characteristics of late adolescence observed in educational studies (Glatthorn, 1993; Maxwell and Meiser, 1997; Probst, 1988) and by Manitoba teachers, and discusses the implications of these characteristics for teachers.

Senior 3 Learners: Implications for Teachers*	
Characteristics of Senior 3 Learners	Significance for Senior 3 Teachers
<p><b>Cognitive Characteristics</b></p> <ul style="list-style-type: none"> <li>• Most Senior 3 learners are capable of abstract thought and are in the process of revising their former concrete thinking into fuller understanding of principles.</li> <li>• Students are less absolute in their reasoning, more able to consider diverse points of view. They recognize that knowledge may be relative to context.</li> <li>• Many basic learning processes have become automatic by Senior 3, freeing students to concentrate on complex learning.</li> <li>• Students have a clearer self-understanding and have developed specialized interests and expertise. They need to connect what they are learning to the world outside the school. Physics must be seen as <i>valuable and necessary</i>.</li> </ul>	<ul style="list-style-type: none"> <li>• Teach to the big picture. Help students forge links between what they already know and what they are learning. Be cognizant of individual differences and build bridges for students who think concretely.</li> <li>• Focus on developing problem-solving and critical thinking skills, particularly those related to STSE and decision making.</li> <li>• Identify the knowledge, skills, and strategies that students already possess, and build the course around new challenges. Through assessment, identify students who have not mastered learning processes at Senior 3 levels and provide additional assistance and support.</li> <li>• Use strategies that enhance students' metacognition. Encourage students to develop scientific skills through exploring areas of interest. Cultivate classroom experts and invite students with individual interests to enrich the learning experience of the class.</li> </ul>

(continued)

\* Senior 3 Learners: Implications for Teachers: Adapted from *Senior 3 English Language Arts: A Foundation for Implementation*. Copyright © 1999 by Manitoba Education and Training. All rights reserved.

<b>Senior 3 Learners: Implications for Teachers (continued)</b>	
<b>Characteristics of Senior 3 Learners</b>	<b>Significance for Senior 3 Teachers</b>
<p><b>Psychological and Emotional Characteristics</b></p> <ul style="list-style-type: none"> <li>• It is important for Senior 3 students to see that their autonomy and emerging independence are respected. They need a measure of control over what happens to them in school.</li> <li>• Students are preparing for senior leadership roles within the school and may be more involved with leadership in their communities.</li> <li>• Students need to understand the purpose and relevance of practices, policies, and processes. They may express their growing independence through a general cynicism about authority and institutions.</li> <li>• Senior 3 students have a clearer sense of identity than they had previously and are capable of being more reflective and self-aware. Some students are more willing to express themselves and disclose their thoughts and ideas.</li> </ul>	<ul style="list-style-type: none"> <li>• Provide choice. Allow students to select many of the resources they will explore and the forms they will use to demonstrate their learning. Collaborate with students in assessment. Teach students to be independent learners. Gradually release responsibility to students.</li> <li>• Provide students with leadership opportunities within the classroom and with a forum to practise skills in public speaking and group facilitation.</li> <li>• Use students' tendency to question social mores to help them develop critical thinking. Negotiate policies and demonstrate a willingness to make compromises. Use students' questions to fuel classroom inquiry.</li> <li>• Provide optional and gradual opportunities for self-disclosure. Invite students to explore and express themselves through their work. Celebrate student differences.</li> </ul>
<p><b>Physical Characteristics</b></p> <ul style="list-style-type: none"> <li>• Many Senior 3 students have reached adult physical stature. Others, particularly males, are still in a stage of extremely rapid growth and experience a changing body image and self-consciousness.</li> <li>• By Senior 3, students are better able to sit still and concentrate on one learning task for longer periods, but they still need interaction and variety. They have a great deal of energy.</li> <li>• Senior 3 students still need more sleep than adults, and may come to school tired as a result of part-time jobs or activity overload.</li> </ul>	<ul style="list-style-type: none"> <li>• Be sensitive to the risk students may feel in public performances and increase expectations gradually. Provide students with positive information about themselves.</li> <li>• Put physical energy to the service of active learning instead of trying to contain it. Provide variety; change the pace frequently; use kinesthetic learning experiences.</li> <li>• Be aware that inertia or indifference may be the result of fatigue. Work with students and families to set goals and plan activities realistically so that school work assumes a higher priority.</li> </ul>

*(continued)*

<b>Senior 3 Learners: Implications for Teachers (continued)</b>	
<b>Characteristics of Senior 3 Learners</b>	<b>Significance for Senior 3 Teachers</b>
<p><b>Moral and Ethical Characteristics</b></p> <ul style="list-style-type: none"> <li>• Senior 3 students are working at developing a personal ethic, rather than following a prescribed set of values and code of behaviour.</li> <li>• Students are sensitive to personal or systemic injustice but are increasingly realistic about the factors affecting social change.</li> <li>• Students are shifting from an egocentric view of the world to one centred in relationships and community. They are able to recognize different points of view and adapt to difficult situations.</li> <li>• Students are becoming realistic about the complexities of adult responsibilities but resist arbitrary authority.</li> </ul>	<ul style="list-style-type: none"> <li>• Explore the ethical meaning of situations in life and in scientific contexts. Provide opportunities for students to reflect on their thoughts in discussion, writing, or representation.</li> <li>• Explore ways decision-making activities can effect social change, and link to the continuum of science, technology, society, and the environment.</li> <li>• Provide opportunities for students to make and follow through on commitments and to refine their interactive skills.</li> <li>• Explain the purpose of every learning experience. Enlist student collaboration in developing classroom policies. Strive to be consistent.</li> </ul>
<p><b>Social Characteristics</b></p> <ul style="list-style-type: none"> <li>• By Senior 3, certain individuals will take risks in asserting an individual identity. Many students, however, continue to be intensely concerned with how peers view their appearance and behaviour. Much of their sense of self is drawn from peers, with whom they may adopt a “group consciousness” rather than making autonomous decisions.</li> <li>• Adolescents frequently express identification with peer groups through slang, musical choices, clothing, body decoration, and behaviour.</li> <li>• Crises of friendship and romance, and a preoccupation with relationships, can distract students from academics.</li> <li>• Students begin to recognize teachers as individuals and welcome a personal connection.</li> </ul>	<ul style="list-style-type: none"> <li>• Ensure that the classroom has an accepting climate. Model respect for each student. Use learning experiences that foster student self-understanding and self-reflection. Challenge students to make personal judgements about situations in life and in their natural environment.</li> <li>• Foster a classroom identity and culture. Ensure that every student is included and valued. Structure learning so that students can interact with peers, and teach strategies for effective interaction.</li> <li>• Open doors for students to study personal relationships in science (for example, through biographies of scientists). Respect confidentiality, except where a student’s safety is at risk.</li> <li>• Nurture and enjoy a relationship with each student. Try to find areas of common interest with each one. Respond with openness, empathy, and warmth.</li> </ul>

## Fostering a Will to Learn: Creating Links between Language and Science

Experiences of intense involvement are optimal opportunities to teach engagement in learning, and teachers should try to ensure they happen frequently in the classroom. Not every learning task, however, can be intrinsically rewarding to every learner. Being a successful learner also requires a high degree of what Corno and Randi (1997) call “sustained voluntary effort”—an attitude expressed in committing oneself to less interesting tasks, persisting in solving problems, paying conscientious attention to detail, managing time, self-monitoring, and making choices between competing values, such as the desire to do well on a homework assignment and the desire to spend the evening with friends. The willingness to make this sustained effort constitutes motivation.

Motivation is a concern of teachers, not only because it is essential to classroom learning, but also because volition and self-direction are central to lifelong learning. Science courses seek to teach students how to interpret and analyze science concepts, and to foster the desire to do so. Motivation is not a single factor that students either bring or do not bring to the classroom. It is multi-dimensional, and individual, and often comprises both intrinsic and extrinsic elements. Students hold certain presuppositions about science learning that affect the way they learn. Teachers can promote certain attitudes and skills to facilitate students’ engagement in each learning task, while recognizing and affirming entry-level abilities.

In considering how they can foster motivation, teachers may explore students’ appreciation of the value (intrinsic and extrinsic) of learning experiences and their belief about their likelihood of success. Good and Brophy (1987) suggest that these two elements can be expressed as an equation; the effort students are willing to expend on a task is a product of their expectation of success and of the value they ascribe to success.

<b>Expectancy</b>	<b>x</b>	<b>Value</b>	<b>=</b>	<b>Motivation</b>
(the degree to which students expect to be able to perform the task successfully if they apply themselves)		(the degree to which students value the rewards of performing a task successfully)		

Teachers may, therefore, want to focus on ensuring students are able to succeed if they apply reasonable effort, and on helping students recognize the value of classroom learning experiences. The following chart provides teachers with suggestions for fostering motivation.

<b>Fostering Motivation*</b>	
<b>Ways to Foster Expectations of Success</b>	<b>Best Practice and Research</b>
<ul style="list-style-type: none"> <li>• Help students to develop a sense of self-efficacy.</li> </ul>	<ul style="list-style-type: none"> <li>• Schunk and Zimmerman (1997) found that students who have a sense of self-efficacy are more willing to participate, work harder, persist longer when they encounter difficulties, and achieve at a higher level than students who doubt their learning capabilities.  Teachers foster student self-efficacy by recognizing that each student can succeed, and communicating that belief to the student. Silver and Marshall (1990) found that a student's perception that he or she is a poor learner is a strong predictor of poor performance, overriding natural ability and previous learning. All students benefit from knowing that the teacher believes they can succeed and will provide the necessary supports to ensure that learning takes place.  Teachers also foster a sense of self-efficacy by teaching students that they can learn how to learn. Students who experience difficulty often view the learning process as mysterious and outside their control. They believe that others who succeed in school do so entirely because of natural, superior abilities. It is highly motivating for these students to discover that they, too, can learn and apply the strategies that successful students use when learning.</li> </ul>
<ul style="list-style-type: none"> <li>• Help students to learn about and monitor their own learning processes.</li> </ul>	<ul style="list-style-type: none"> <li>• Research shows that students with high metacognition (students who understand how they learn) learn more efficiently, are more adept at transferring what they know to other situations, and are more autonomous than students who have little awareness of how they learn. Teachers enhance metacognition by embedding, into all aspects of the curriculum, instruction in the importance of planning, monitoring, and self-assessing. Turner (1997) found that teachers foster a will to learn when they support "the cognitive curriculum with a metacognitive and motivational one" (p. 199).</li> </ul>
<ul style="list-style-type: none"> <li>• Assign tasks of appropriate difficulty, communicating assessment criteria clearly, and ensuring that students have clear instruction, modelling, and practice so they can complete the tasks successfully.</li> </ul>	<ul style="list-style-type: none"> <li>• Ellis et al. (1991) found that systemic instruction helps students learn strategies they can apply independently (see <i>Instructional Strategies</i>, Section 2, p. 33).</li> </ul>

*(continued)*

\* **Fostering Motivation:** Adapted from *Senior 3 English Language Arts: A Foundation for Implementation*. Copyright © 1999 by Manitoba Education and Training. All rights reserved.

<b>Fostering Motivation (continued)</b>	
<b>Ways to Foster Expectations of Success</b>	<b>Best Practice and Research</b>
<ul style="list-style-type: none"> <li>• Help students to set specific and realistic personal goals and to learn from situations where they do not attain their goals, and celebrate student achievements.</li> <li>• Offer choices.</li> <li>• Set worthwhile academic objectives.</li> <li>• Help students to learn about and monitor their own learning processes.</li> <li>• Ensure that scientific experiences are interactive.</li> </ul>	<ul style="list-style-type: none"> <li>• Research shows that learning is enhanced when students set goals that incorporate specific criteria and performance standards (Foster, 1996; Locke and Latham, 1990).</li> <li>• Teachers promote this by working in collaboration with students in developing assessment (see <i>Assessment in Senior 3 Physics</i> [Section 3]; and Appendix 5).</li> <li>• Intrinsic motivation is closely tied to students' self-selection of topics, texts, activities, and creative forms. Teachers may involve the students in the choice of a topic for thematic development. Support students in the search for learning resources that are developmentally appropriate and of high interest, and encourage students to bring the world views they value into the classroom. Self-selection allows students to build their learning on the foundation of their personal interests and enthusiasm.</li> <li>• Rather than asking students to execute isolated skills or perform exercises that are without context, embed instruction in meaningful events and activities that simulate real-world settings, and ensure that students share performances and products with a peer audience.</li> <li>• In teaching specific learning strategies, focus on the usefulness of each strategy for making information meaningful, or for expressing ideas of importance to students. Emphasize the importance of science to the richness and effectiveness of students' lives, and de-emphasize external rewards and consequences such as marks.</li> <li>• A community that encourages students to share their learning with each other values science. Teachers who model curiosity, enthusiasm, and pleasure in learning science-related concepts, and who share their experiences, foster motivation for scientific literacy.</li> </ul>

### **Creating a Stimulating Learning Environment**

A vital science class grows out of, and is reflected in, a stimulating and inviting physical environment. While the resources and physical realities of classrooms vary, a well-equipped science classroom offers or contains a variety of resources that help stimulate learning. It is helpful to involve students in the classroom design.

Ways to create a stimulating learning environment include the following:

- **FLEXIBLE SEATING ARRANGEMENTS:** Use moveable desks or tables to design seating arrangements that reflect a student-centred philosophy and that allow students to interact in various configurations.

- **A MEDIA-RICH ENVIRONMENT:** Have a classroom library of books for self-selected reading. The classroom library may include science periodicals, newspaper articles, newsletters, Internet articles, science-fiction literature, and students' published work. It may also include a binder of student reviews and recommendations, and may be decorated by student-designed posters or book jackets. Classroom reference materials could include dictionaries/encyclopedias of science, books of facts, software and CD-ROM titles, past exams collated into binders, and manuals.
- **ACCESS TO ELECTRONIC EQUIPMENT:** Provide access to a computer, television, video cassette recorder/DVD-Rom, and video camera, if possible.
- **WALL DISPLAYS:** Exhibit posters, Hall of Fame displays, murals, banners, and collages that celebrate student accomplishments. Change these regularly to reflect student interests and active involvement in the science classroom.
- **DISPLAY ITEMS AND ARTIFACTS:** Have models, plants, photographs, art reproductions, maps, newspaper and magazine clippings, fossils, musical instruments, et cetera, in your classroom to stimulate inquiry and to express the link between the science classroom and the larger world.
- **COMMUNICATION:** Post checklists, processes, and strategies to facilitate and encourage students' independent learning. Provide a bulletin board for administrative announcements and schedules.

### **Language Learning Connected to Science**

Science curricula involve all aspects of language and literacy development. Halliday suggests that as students actively use the language arts, they engage in three kinds of language learning, which can be linked to broader scientific literacy (Strickland and Strickland, 1997).

- **STUDENTS LEARN LANGUAGE:** Language learning is a social process that begins at infancy and continues throughout life. Language-rich environments enhance and accelerate the process. Terminology-rich science has a role in new language development.
- **STUDENTS LEARN THROUGH LANGUAGE:** As students listen, read, or view, they focus primarily on making meaning from the text at hand. Students use language to increase their knowledge of the world.
- **STUDENTS LEARN ABOUT LANGUAGE:** Knowledge of language and how it works is a subject in and of itself; nevertheless, science as a discipline of inquiry relies on a particular use of language for effective communication. Consequently, students also focus on language arts and its role when applied to science. Scientific literacy learning is dynamic and involves many processes. The following graphic identifies some of the dynamic processes that form the foundation for effective literacy learning in science classrooms.

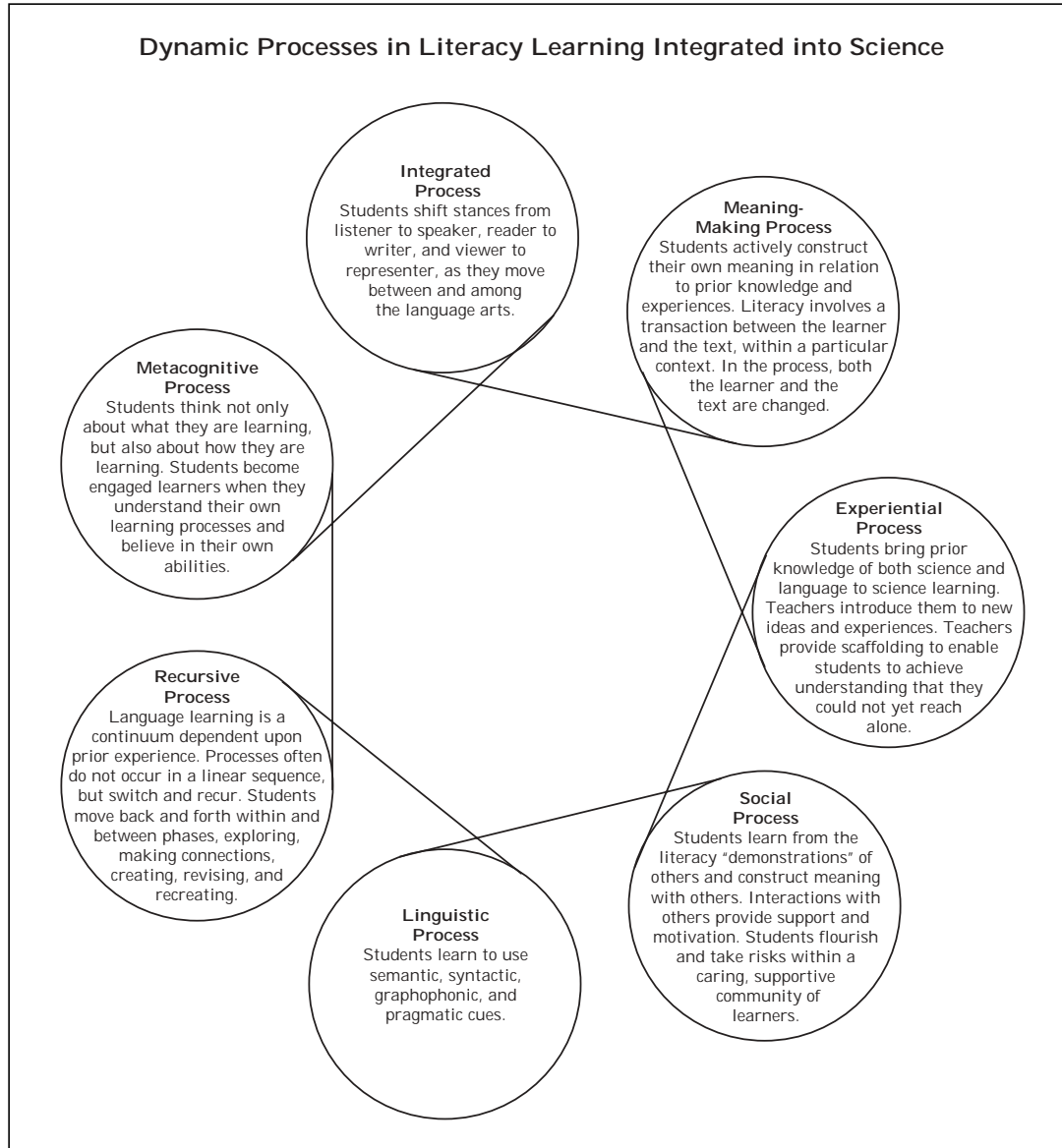

### Ethical Issues

The development of topics within Senior 3 Physics should lead to issues and questions that go beyond the traditional curriculum. For example, medical biophysics, or the implementation of international protocols related to the prospects of global climate change, raise questions of ethics, values, and responsible use of the products of the physical sciences. The environmental consequences of the industrial applications of chemistry, or the atmospheric physics of climate change, raise issues of considerable importance, as do the topics of nuclear waste disposal and weapons procurement. These are among the important issues that science is often called upon for advice. As students and teachers address these issues, they will naturally be drawn to the study of the underlying scientific concepts. Students should realize that science only provides the background for informed personal and social decisions, and that, as



informed decision makers, they may have an impact on society and the world. Students of physics are not immune to the importance of these aspects of science in a modern, post-industrial world.

Some students and parent(s) may express concern because the perspectives of current science conflict with personal systems of belief. These individuals have a right to expect that science and the public educational system will respect those beliefs, though this does not preclude such issues arising in the classroom. Teachers should explain to students that science is one way of learning about the universe and our unique place embedded in it, and that other explanations, in addition to those of the traditional western sciences, have been put forth—particularly in the realm of cosmogony.

### **Diversity in the Classroom**

Students come from a variety of backgrounds and have distinct learning requirements, learning and thinking approaches, and prior knowledge and experiences. Their depth of prior knowledge varies, reflecting their experiences inside and outside the classroom. Some entry-level knowledge held by students may be limited or incorrect, impeding new learning. For new learning to occur, it is important for teachers to activate prior knowledge, correct misconceptions, and encourage students to relate new information to prior experiences. Manitoba's cultural diversity provides opportunities for embracing a wealth of culturally significant references and learning resources in the Senior Years science classroom. Students from various backgrounds bring socially constructed meanings, references, and values to science learning experiences, as well as their unique learning approaches. As noted in *Senior Years Science Teachers' Handbook*, "To be effective, the classroom must reflect, accommodate, and embrace the cultural diversity of its students" (Manitoba Education and Training, 1997).

In addition, cultural influences can affect how students think about science: reasoning by analogy or by strict linear logic; memorization of specific correct responses or generalization; problem solving by induction or by deduction; or needing to learn through hands-on apprenticeship to gain one aspect of a skill before moving on to the next step (Kolodny, 1991). Cultural prohibitions permeate some societies; for example, values that discourage assertiveness, outspokenness, and competitiveness in some cultures can result in behaviour that can be interpreted as being indifferent, having nothing to say, or being unable to act decisively (Hoy, 1993; NRC, 1997). The problems engendered by these cultural differences are often beyond the ability of teachers of advanced courses to handle on their own. In many such cases, support from other members of the school staff is essential.

## Learning Resources

Traditionally, the teaching of science in Senior Years has largely been a textbook-centred enterprise. The use of a single textbook as the sole resource for the teaching and learning of science severely restricts the development of knowledge, skills, and attitudes that are critical for today's students. Furthermore, it promotes the idea that all answers are enshrined in a textbook. The successful implementation of Senior 3 Physics depends on a resource-based learning approach, in which textbooks are used only as one of many reference sources. Research suggests that we should provide a wide range of learning resources for structuring teaching and learning experiences. These include human resources, textbooks, magazines/journals, films, audio and video recordings, computer-based multimedia resources, the Internet, and other materials.

Resources referenced in this curriculum include print reference material such as *Senior Years Science Teachers' Handbook: A Teaching Resource* (Manitoba Education and Training, 1997) and *Science Safety: A Kindergarten to Senior 4 Resource Manual for Teachers, Schools, and School Divisions* (Manitoba Education and Training, 1997). In addition, numerous articles from the physics education research community are recommended to teachers.

The choice of learning resources, such as text(s), multimedia learning resources (including video, software, CD-ROMs, microcomputer-based laboratory [MBL] probeware, calculator-based laboratory [CBL] probeware), and websites, will depend on the topic, the local situation, reading level of the students, background of the teacher, community resources, and availability of other materials. A concerted effort should be made to use appropriate learning resources from a wide variety of sources, as not all curricular outcomes can be achieved by using any one resource in the study of a particular topic.

To help teachers and principals select learning resources for Senior 3 and Senior 4 physics, Manitoba Education and Youth has recently published *Physics 30S and Physics 40S Learning Resources: Annotated Bibliography: A Reference for Selecting Learning Resources (2003)*. This annotated bibliography is published online at:

<<http://www.edu.gov.mb.ca/ks4/learnres/bibliographies.html>>.

## Using This Curriculum Document

Physics curricula in the past have been primarily focussed on presenting a breadth of knowledge (that is, a large amount of content) deemed essential, and with a focus on the mathematical manipulation of algorithms. While this curriculum continues to be concerned with students acquiring relevant knowledge and appropriate mathematical treatment of concepts, it is also concerned both with fostering the development of various skills (context-based process skills, decision-making skills, problem-solving skills, laboratory experimental skills, critical thinking skills, independent learning skills), and with effecting a change of viewpoint. A strong focus of Senior 3 Physics is to link science to the experiential life of the students.

By offering a multidisciplinary focus where appropriate, Senior 3 Physics provides a new set of foundations for fostering increased scientific literacy. The curriculum, consisting of 29 General Learning Outcomes (GLOs), each with a number of Specific Learning Outcomes (SLOs) linked to them, will build upon what students know and are able to do as a result of their studies in Kindergarten to Senior 2 Science (see Figure 6: *Kindergarten to Senior 2 Topic Chart*, Section 1, page 16).

Senior 3 Physics assumes 110 hours of instructional time, and is designed to include formal assessments, field excursions, and related co-curricular efforts.

## **Effective Teaching in Physics: What the Research Says to Teachers**

### **Findings of Research on How Students Learn**

A number of summaries of the instructional implications of recent research on learning have been prepared. The National Research Council report *How People Learn: Brain, Mind, Experience, and School: Expanded Edition* (Bransford et al., 2000) can be adapted and elaborated specifically for the study of physics. That report leads to the following implications for effective physics instruction.

- 1. Effective teachers draw out and work with students' current understandings, including those understandings students bring with them to the course and those they develop as the course progresses.**

There is an emerging consensus in science education research, including a substantial body of work specific to introductory physics, that, to be effective, instruction must elicit, engage, and respond substantively to student understandings (Champagne, Gunstone, and Klopfer, 1985; Clement, 1983; Hake, 1998; Hestenes, Wells, and Swackhamer, 1992; McDermott and Redish, 1999). There are now a number of examples of curricula and materials designed to support interaction with students' prior understandings, and there is evidence that these approaches can achieve progress in understanding that is not possible for most students with traditional methods.

- 2. Effective teachers address students' metacognitive skills, habits, and epistemologies.**

Students need to understand not only the concepts of physics, but also the nature of knowledge and learning (Hammer, 1995; Hewson, 1985; McDermott, 1991; Reif and Larkin, 1991; White and Frederiksen, 1998). Many students arrive at physics courses, including advanced-treatment courses such as Physics AP, expecting to learn by memorizing formulas disconnected from each other, as well as from the students' experiences of the physical world. Effective instruction challenges these expectations, helping students to see physics learning as a matter of identifying, applying, and refining their current understanding. Students learn to examine assumptions hidden in their reasoning; to monitor the quality and consistency of their understanding; to formulate, implement, critique, and refine models of physical phenomena; and to make use of a spectrum of appropriate representational tools. By the end of a physics course, students develop a rich

sense of the coherent, principled structure of physics and are both able and inclined to apply those principles in unfamiliar situations. In short, effective instruction should work toward the objectives identified in the *Manitoba Foundations for Science Literacy*.

**3. Effective teachers are sophisticated diagnosticians of student knowledge, reasoning, and participation.**

How teachers respond to student thinking depends critically on what they perceive in that thinking, on what they interpret to be the strengths and weaknesses of the students' understanding and approach. Effective teachers continually gather information to support this ongoing assessment from several different sources: written work on assignments, tests, and quizzes; classroom discussions; and contact with students outside the classroom. They ask students to explain their reasoning throughout their work, particularly through the appropriate and measured use of differentiated instruction techniques. Upon gaining new insights into student understanding, effective teachers adapt their instructional strategies and assessments.

**4. Effective teachers teach a smaller number of topics in greater depth, providing many examples in which the same concept is at work.**

This is a common refrain in findings from education research, often expressed in the slogan "less is more." In part, this finding is an implication of the previous two: drawing out and working with student understandings and addressing metacognitive skills and habits all take time, and this necessitates a reduction in the breadth of coverage. Education research also suggests that coming to understand a concept requires multiple encounters in multiple contexts. This finding is reflected across innovations in this physics curriculum that have drawn on the "spiralling" approach fostered throughout all Kindergarten to Senior Years science in Manitoba.

**Making Interdisciplinary Connections in the Physics Classroom**

An important issue for a field as ancient as physics is how it adapts to the needs of society in a given place and time. The field of physics today faces a period of transition.

- A period in which technology and knowledge-based industries are the primary drivers of the national economy has begun.
- A period in which other areas of science, such as microbiology and genetics, will undergo rapid progress has also begun.
- The increasing availability, power, and sophistication of computational hardware and software will make possible novel quantitative descriptions of the physical universe. Society in general appears to be rapidly becoming more and more knowledge based. Enormous quantities of information are instantly available on ubiquitous computers.

Physicists will need to be able to apply the body of knowledge developed within physics to totally new areas. In other words, physicists will be asked to become more interdisciplinary; they will have to apply their special knowledge and methods to problems that cross the boundaries of traditional disciplines.

On the other hand, the topics that possess several features that naturally allow students to begin to confront interdisciplinary issues are welcome, and align more closely to the new emphases outlined in the *Manitoba Foundations for Science Literacy*. First, there is the provision for interdisciplinary options (biomedical physics, historical physics, the nature of science as seen through physics, et cetera) that teachers may choose to create. Collaborative group work of students creates its interdisciplinary dimension through ownership of a collaborative scientific investigation. Such projects can easily involve applying knowledge and methods from several different scientific fields. Increased interdisciplinary content could be added to physics courses by developing more contexts such as the biomedical physics unit mentioned above. Alternatively, the enriched physics course might choose to explore examples illustrating how fundamental physical principles apply to a wide variety of areas. For example, the elastic properties of DNA molecules might be used to discuss the range of validity of Hooke's law for spring forces. Biological cell membranes could be used to construct interesting examples of electrical potential differences and electric fields. In agreement with the National Research Council's *National Science Education Standards (NSES)* (1996), Manitoba Education and Youth encourages teachers to include some experiences with the interdisciplinary applications of physics when implementing the physics curriculum.

### **Unit Development in Physics**

Senior 3 Physics is driven by specific learning outcomes that can be arranged in a variety of groupings. This design empowers teachers to plan appropriate learning experiences based on the nature of their students, school, and community. Teachers are encouraged to seek their own instructional design with the new curriculum, to share approaches and experiences with colleagues, and to use it to develop and extend student experiences and understandings in new ways.

Working with bigger ideas can allow for a more in-depth inquiry. Organizing around a problem or theme will generally present information in the context of real-world applications (Willis, 1992). For instance, the treatment of vector analysis or free-body diagrams—usually taught in isolation as discrete mastery skills—could be better served by presenting these concepts at the time when the context will demand their use. Throughout the year, provide students with opportunities to uncover concepts from among the sciences in a substantial way, and to make coherent connections among them to physics.

Science deals with major themes in which people are already interested or can readily be interested: life and living things, matter, the universe, information, the 'made-world'. A primary reason, therefore, for teaching science to young people is to pass on to them some of this knowledge about the material world, simply because it is both interesting and important—and to convey the sense of excitement that scientific knowledge brings (Millar and Osborne, 1998).

For teachers adopting a “thematic” or “big ideas from physics” approach to organizing the course, choosing an effective theme is critical to the success of such a pathway. Involving students in the selection of a theme (or the important subcomponents of a compulsory topic) will encourage and motivate them by recognizing their interests.

A theme should:

- be broad enough for students to find personal areas of interest;
- promote learning;
- have substance and apply to the real world;
- have relevant materials readily available;
- be meaningful and age-appropriate;
- have depth;
- integrate across the disciplines of physics, biology, chemistry, and geosciences; and
- fascinate students (Willis, 1992).

### **A View of Physics Education: Toward Modes of Representation**

Ask your students to respond, in one sentence, to the question “What is physics?” Responses tend to describe previous experiences with physics content: “physics is motion” or “physics is the study of energy and matter.” Other responses are more global: “physics is the study of the universe” or “physics is the science of all things.” The relationship of mathematics to physics is predominant; a common lament is “physics is math” or “physics is figuring out the simple things in everyday life in a mathematically complex way.” These responses indicate that students see mathematics as *the* process of physics. Many see physics as an important aspect of their preparation for an uncertain future, but with a varying sense of what physics really is and what it could do for them.

What is physics? Although answers vary, if you consider the various branches of physics and the underlying principles, a common theme exists. Physics is the study of *relationships* in the world we perceive around us. However, those relationships are embedded in a social and historical context—a set of lenses through which the relationships are perceived and acted upon. For instance, we contemplate “something interesting,” then build models to identify fundamental characteristics to determine how they interact and influence each other. From these relationships we are able to predict the behaviour of other “interesting things” that have the same or similar parameters. A major component of physics, then, is the study of relationships in a variety of different forms. What makes the study of physics so difficult for so many is that relationships can be represented in many different ways—and too often in just one manifestation, the mathematical symbolic relationship. To facilitate teaching and learning, it is important to understand these modes of representation and their relationship to each other.

## The Modes of Representation

### The Visual Mode

To illustrate these modes of representation, consider an example. A 0.5-kg mass is suspended from a spring (Figure 1). If we suspend a 1.0-kg mass and a 1.5-kg mass from identical springs, we perceive the relationship between the force that acts on the spring and the stretch of the spring. This is what we would call the *visual* mode of representing a relationship. Its basis is in the “real” world and our perceptions of this world.

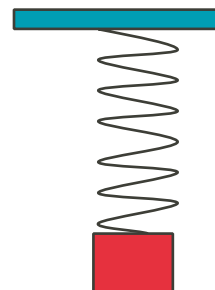

In the visual mode we formulate a relationship between two variables and then test our hypothesis by observation and experimentation. As the force increases, the stretch increases. Sometimes, we can even determine the exact relationship. In this case, since the masses in Figure 1 line up in a straight line, the applied force and stretch must increase in some predictable proportion.

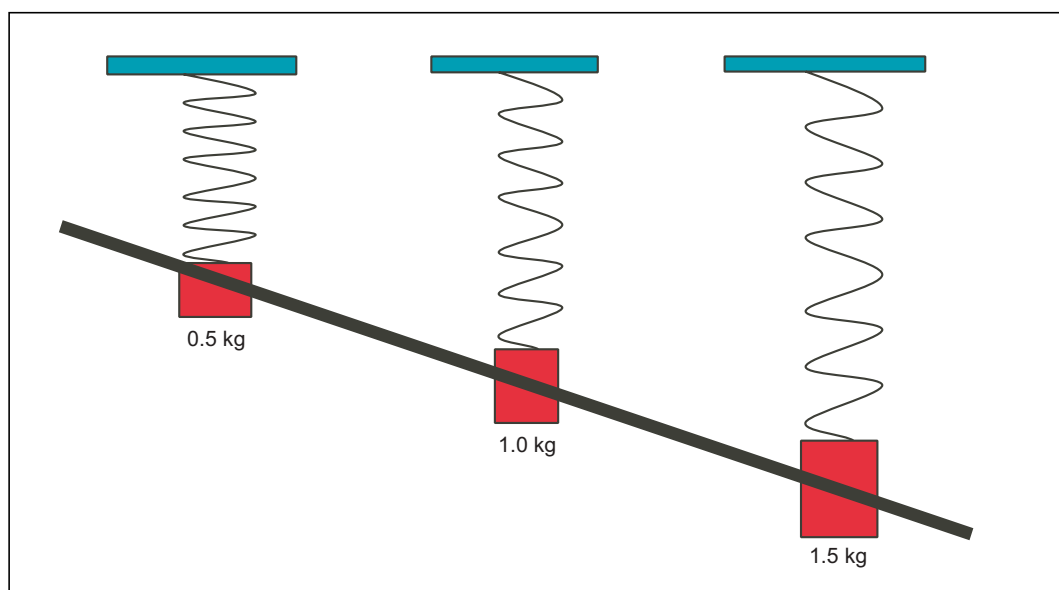

Figure 1

The visual mode embodies more than conjecture and observation. It incorporates critical and creative thinking as we build and modify models of nature that act as a foundation for our investigations. The “real” world is conceptualized by a set of guiding assumptions we imagine to be true. We may internalize a model to aid this conceptualization, and then we test this model using experiments. A successful model has explanatory and predictive capabilities. A model may incur discrepant events, which may force us to reconsider and modify our model. Our model may be falsified, in which case we abandon the model in search of a more complete and accurate model. For instance, the model of electric charge provides a foundation for the examination

of electric phenomena. Historically, the fluid and particle models of charge accounted for experimental observations. However, as our ideas about the structure of matter evolved, the particle model provided a more reliable, predictive, and robust explanatory model.

Although we can make some general descriptions of relationships (as force increases, stretch increases), we can not always determine an exact relationship using the visual mode of representation. Therefore, we quantify the characteristics and compare the numbers. This is called the **numerical** mode of representation.

### Numerical Mode

In the numerical mode of representation, we operationally define fundamental properties and use measurement to collect data. We can then examine the data to determine an exact relationship. The numerical mode dictates an understanding of proportioning and numerical patterns (e.g., if  $F$  doubles,  $X$  doubles, and if  $F$  triples,  $X$  triples). This suggests a direct proportion, and we can formulate our law. However, in most cases, the collection of data results in systematic errors. Determining the relation by inspection of the data can be very difficult. A picture, however, is worth a thousand numbers. Graphing the data usually gives a clearer picture of the relationship. It could be looked upon, for students, as a preparation for examining closely a “picture of the numbers.”

$F$ (N)	$X$ (m)
5.0	0.2
10.0	0.4
15.0	0.6
20.0	0.8



### Graphical Mode

The graphical mode of representation is a mathematical picture of the relationship. Fortunately, there are a limited number of pictures one needs to know to determine relationships. In fact, at the introductory Senior 3 Physics level, it is only necessary to know three pictures: a straight line, a power curve, and an inverse curve. By adjusting the data to “straighten the curve,” we can determine the exact relationship and formulate a law that can be represented in a symbolic manner.

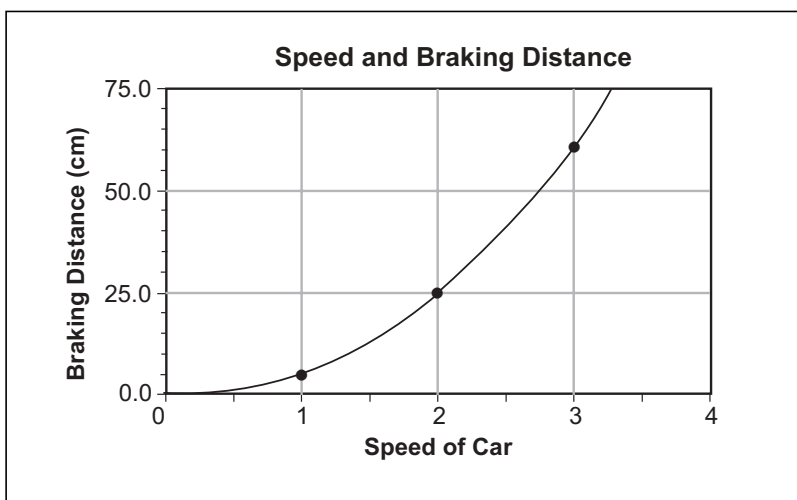
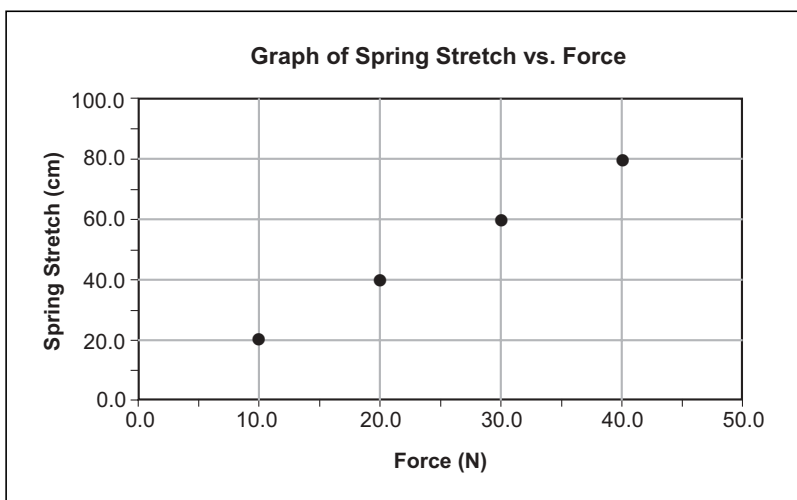

### Symbolic Mode

The fourth mode of representation is the **symbolic mode**. We represent the relationship as an algebraic formula, which can be applied to other physical events that are similar in nature.

For instance,

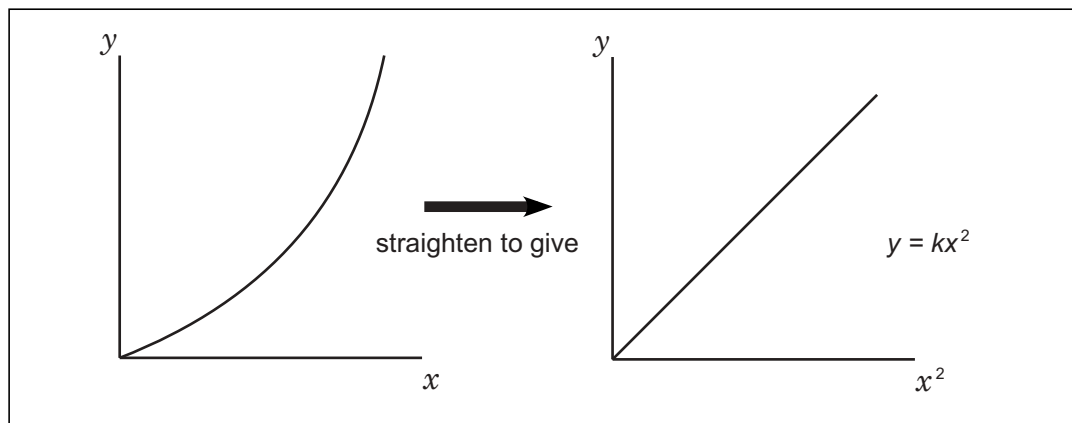

Therefore, we can represent relationships in four different modes: visual, numerical, graphical, and symbolic. In our model of physics education, students are able to function in each mode to demonstrate complete understanding and mastery of the concepts.

### The Importance of the Modes of Representation

It is easy to become caught up in a single mode, especially the symbolic, when it comes to the teaching and learning of physics. Students often complain about the number of formulas in their physics course, or even question their purpose. They dutifully memorize equations and notation, learn to substitute for variables, and arrive at numeric solutions. Students and teachers can easily become trapped exclusively within the symbolic mode of representation. Instruction using the symbolic mode is easy because little or no preparation is required. The teacher, already grounded in mathematical principles, only needs to derive an equation algebraically. This "out of context" treatment of relationships between the physical/conceptual (i.e., visual mode variables) and the symbolic presents tremendous difficulties for most students, including those students who are apparently mathematically competent.

Meaningful connections between the symbolic and physical/conceptual modes are difficult to make in a de-contextual setting. Many teachers' own instruction in physics was primarily in the symbolic mode and they may never have mediated their own conceptual difficulties. Students taught exclusively in the symbolic mode often know how to arrive at "cookbook" answers, but they rarely understand the physics or retain any of the concepts. In fact, their difficulties rarely focus on physics. Confusion appears because of notation, similar types of equations, various algebraic representations of formulas, and calculations. As soon as physical concepts are necessary, such as in word problems beyond the "plug and slug" variety, success rates decrease dramatically. Research in

physics education, such as Hestenes' et al. (1992) "Force Concept Inventory" and McDermott and Schaffer's (1992) circuit tests, indicates that even advanced students cannot operate in the physical/conceptual domain. This, of course, may not be surprising if their instruction has been almost exclusively in the symbolic mode of representation.

Students need to develop their understanding of relationships more completely, and develop skills in each mode of representation. Students should be able to transfer between modes both fluidly and with facility. Moving through the modes is not necessarily done in order. A "real scientist" can begin investigations in any mode and transfer easily through any combination of modes. Students who demonstrate a complete understanding of physical/conceptual relationships should be able to move from mode to mode in any order.

While fluency with the modes of representation provides a solid foundation for physics education, it is, of itself, not complete when it comes to portraying the nature of scientific activity. Albert Einstein, while developing his theory of relativity, conceptualized an hypothesis and then deduced a series of laws symbolically from a set of fundamental assumptions about time and space. He left it to others to observe, then refute or confirm his propositions. Historical perspectives, and an understanding of the nature of science, will move students toward a more philosophically valid treatment of physics.

**To Sum Up the Modes of Representation for Physics Teachers**

**Visual:** encourage students to discuss the representations they see and experience

**Numeric:** use student-generated measurements; always in the context of activities

**Graphical:** carefully plot graphs; get the "picture of the numbers," not "this is a picture of the world"

**Symbolic:** emphasize the concept first, then initially apply formulas as word definitions; only then work "type" problems using formulas; ideally, formulas are memorized only in certain instances

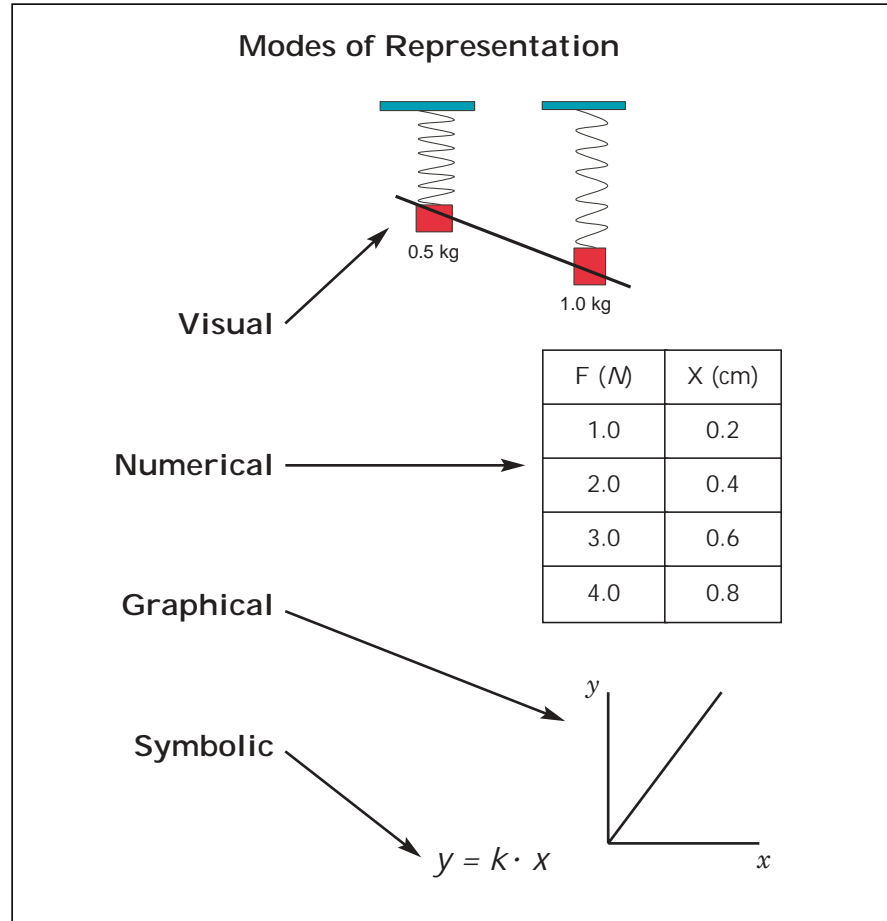

### Toward an Instructional Philosophy in Physics

Teaching Senior 3 Physics with a focus on both content and processes should naturally allow for the use of a variety of instructional strategies. These strategies include the collection and analysis of data from both laboratory and field work, group and individual instruction, a diversity of questioning techniques, decision making, problem solving, design process activities, and a resource-based approach to learning. Senior Years science programming should foster critical thinking skills and promote the integration of knowledge and application of facts to real-life situations. Scientific concepts from other Senior Years science courses may become part of the subject matter as the Senior 3 Physics course develops in the classroom. This is a valuable and useful means of reinforcing and validating those concepts as having relevant and contextual applications.

In general, physics is, in part, a way of thinking that has rules for judging the validity of answers applicable to everyday life. It can be portrayed as intense human activity, full of trial and error, that is influenced by cultural priorities and humanistic perspectives. The myth of total objectivity that often permeates scientific dialogue also needs to be exposed and discussed. Among the natural sciences, “scientific truth” is no longer viewed as an objective reality awaiting discovery; rather, it is placed in the context of something always to be sought. In recognition of the tentative nature of current knowledge claims, “scientific truth” is not a goal that can be reached in absolute terms, but can remain as one of the hallmarks of the traditions of scientific practice.

Encourage students to make distinctions between what is observable and testable, as well as the abstract deductions, models, and themes that derive from evolving scientific research and thinking.

Conceptual knowledge in science can also be integrated with principles from other disciplines. Social, historical, and political implications, if included, provide an opportunity for students to develop a facility to communicate ideas effectively through verbal and written expression. Finally, students could be provided with an opportunity to develop an awareness of the options available to them for careers and vocations in the wide diversity of sciences.

Senior 3 Physics, as a component of young people’s whole educational experience, will assist in preparing them for a full and satisfying life in the 21st century. This course will sustain and develop the curiosity of young people about the natural world around them, and build up their confidence in their ability to inquire into its behaviour, now and in the future. It seeks to foster a sense of wonder, enthusiasm, and interest in science so that young people feel confident and competent to engage with everyday scientific and technological applications and solutions. As students study a range of topics through various subdisciplines of physics, they will acquire a broad, general understanding of the important ideas and explanatory frameworks of the field as a whole, including the procedures of scientific inquiry that have had a major impact on our material environment and on our culture. They will develop an appreciation for why these ideas are valued and the underlying rationale for decisions that they may wish, or be advised, to take in everyday contexts, both now and in later life. They will be able to understand, and respond critically to, media reports of issues with a science (particularly a physics-related) component. They will feel empowered to hold and express a personal point of view on issues with a science component that enter the arena of public debate, and perhaps to become actively involved in some of these issues (Millar and Osborne, 1998, p. 12).

## Results-Based Learning

In results-based learning, the programming focus is on what students know and can do, rather than on what material is “covered.” The learning outcomes are an elaboration of the knowledge, strategies, and skills and attitudes expected of each Senior 3 Physics student. All programming decisions are directed toward addressing the gap between the students’ present level of performance and the performance specified in the learning outcomes.

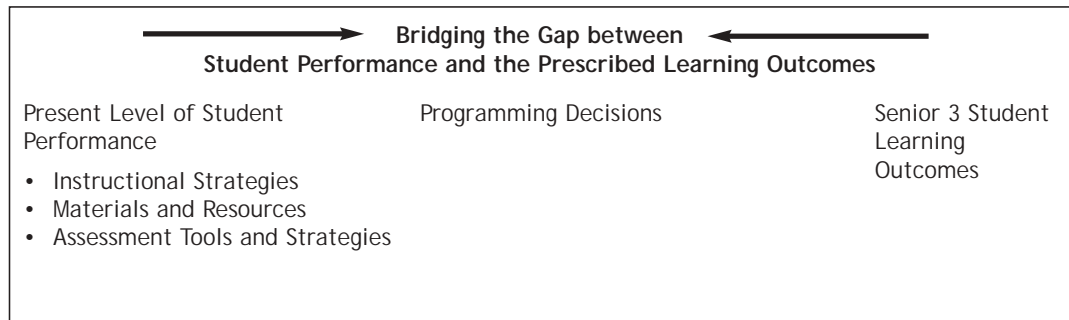

The student learning outcomes are not taught separately or in isolation. Nor are they taught consecutively in the order in which they appear in the curriculum documents. Most lessons or units draw on knowledge, strategies, and skills and attitudes addressed in several or all general learning outcomes. In the process of planning, teachers are encouraged to identify the learning outcomes they intend to assess, and link all assessment to the specific learning outcomes.

In implementing results-based curricula, experienced teachers may find that they use many of the instructional strategies and resources they have used previously. However, the nature of results-based learning will reshape their programming in several ways:

- Planning is ongoing throughout the semester or year because instruction is informed by learning requirements that become evident through continuous assessment.
- Some learning outcomes, especially skills and attitudes outcomes, are addressed repeatedly in different ways throughout the school semester or year. As students develop new scientific knowledge, strategies, and skills and attitudes, they need to practise and refine those they have previously experienced.

## Varied Instructional Approaches

Teachers wear a number of different “pedagogical hats,” and change their teaching style relative to the cognitive gains, attitudes, and skills demanded of the task at hand. In planning instruction for Senior 3 Physics, teachers may draw upon a repertoire of instructional approaches and methods and use combinations of these in each unit and lesson. Many suggestions are contained in this document.

Instructional approaches may be categorized as:

- direct instruction;
- indirect instruction;
- experiential learning;
- independent study; and
- interactive instruction.

Most teachers draw from all these categories to ensure variety in their classroom learning experiences, to engage students with various intelligences and a range of learning approaches, and to achieve instructional goals.

The following diagram displays instructional approaches and suggests some examples of methods within each approach. Note that the approaches overlap.

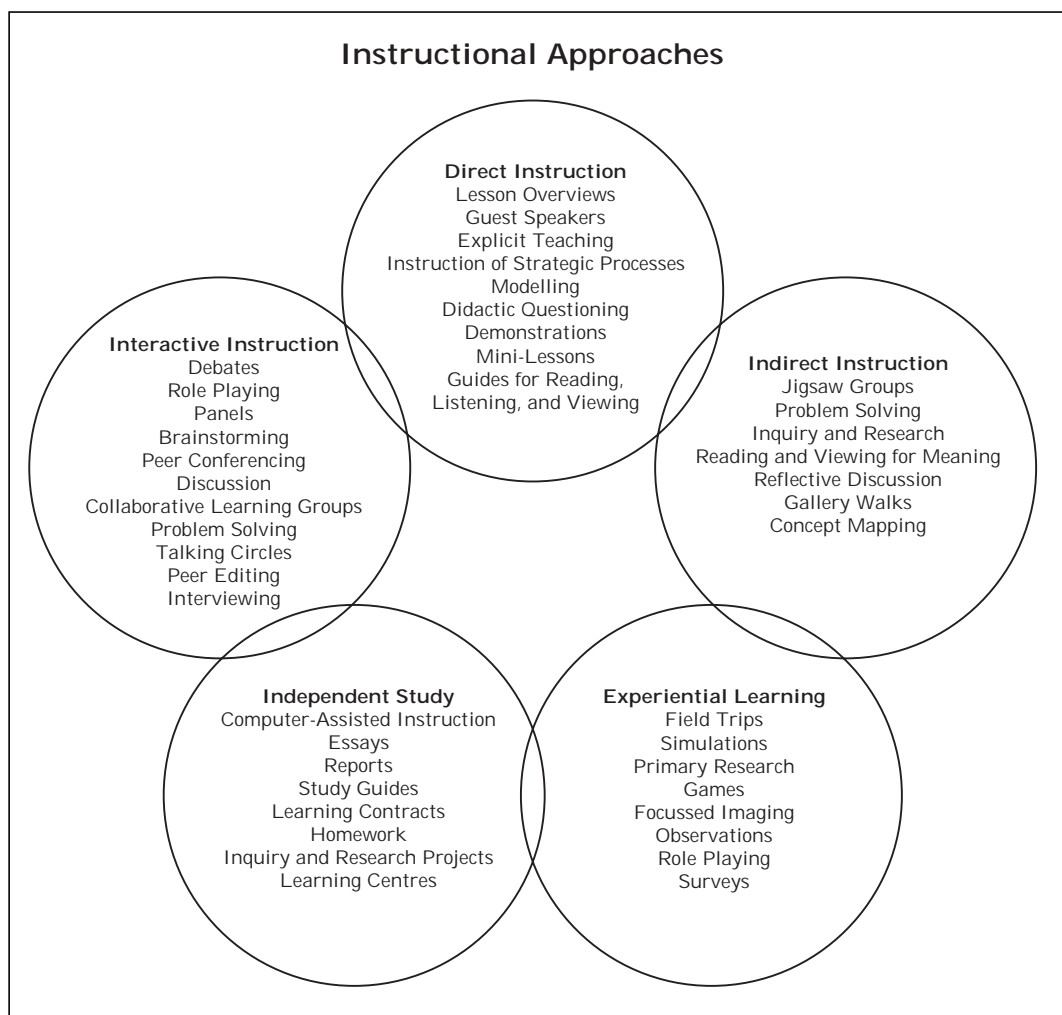

**Instructional Approaches:** Adapted from *Instructional Approaches: A Framework for Professional Practice*. Copyright © 1991 by Saskatchewan Education. Reprinted by permission. All rights reserved.

## Instructional Approaches

In selecting instructional approaches and methods, teachers consider which combination will assist students in achieving the learning outcomes targeted for a particular lesson or unit. Teachers consider the advantages and limitations of the approaches and methods, as well as the interests, knowledge, and skills and attitudes of their students. Some of these elements are represented in the following chart.

Instructional Approaches: Roles, Purposes, and Methods				
Instructional Approaches	Roles	Purposes/Uses	Methods	Advantages/ Limitations
<b>Direct Instruction</b>	<ul style="list-style-type: none"> <li>Highly teacher-directed</li> <li>Teacher ensures a degree of student involvement through didactic questioning</li> </ul>	<ul style="list-style-type: none"> <li>Providing information</li> <li>Developing step-by-step skills and strategies</li> <li>Introducing other approaches and methods</li> <li>Teaching active listening and note making</li> </ul>	Teachers: <ul style="list-style-type: none"> <li>Explicit teaching</li> <li>Lesson overviews</li> <li>Guest speakers</li> <li>Instruction of strategic processes</li> <li>Lecturing</li> <li>Didactic questioning</li> <li>Demonstrating and modelling prior to guided practice</li> <li>Mini-lessons</li> <li>Guides for reading, listening, and viewing</li> </ul>	<ul style="list-style-type: none"> <li>Effective in providing students with knowledge of steps of highly sequenced skills and strategies</li> <li>Limited use in developing abilities, processes, and attitudes for critical thinking and interpersonal learning</li> <li>Students may be passive rather than active learners</li> </ul>
<b>Indirect Instruction</b>	<ul style="list-style-type: none"> <li>Mainly student-centred</li> <li>Role of teacher shifts to facilitator, supporter, resource person</li> <li>Teacher monitors progress to determine when intervention or another approach is required</li> </ul>	<ul style="list-style-type: none"> <li>Activating student interest and curiosity</li> <li>Developing creativity and interpersonal skills and strategies</li> <li>Exploring diverse possibilities</li> <li>Forming hypotheses and developing concepts</li> <li>Solving problems</li> <li>Drawing inferences</li> </ul>	Students: <ul style="list-style-type: none"> <li>Observing</li> <li>Investigating</li> <li>Inquiring and researching</li> <li>Jigsaw groups</li> <li>Problem solving</li> <li>Reading and viewing for meaning</li> <li>Reflective discussion</li> <li>Concept mapping</li> </ul>	<ul style="list-style-type: none"> <li>Students learn effectively from active involvement</li> <li>Allows for high degree of differentiation and pursuit of individual interests</li> <li>Teacher requires excellent facilitation and organizational skills</li> <li>Focussed instruction of content and concepts may be difficult to integrate</li> </ul>

(continued)

**Instructional Approaches:** Adapted from *Senior 3 English Language Arts: A Foundation for Implementation*. Copyright © 1999 by Manitoba Education and Training. All rights reserved.



Instructional Approaches: Roles, Purposes, and Methods (continued)				
Instructional Approaches	Roles	Purposes/Uses	Methods	Advantages/Limitations
<b>Interactive Instruction</b>	<ul style="list-style-type: none"> <li>• Student-centred</li> <li>• Teacher forms groups, teaches and guides small-group skills and strategies</li> </ul>	<ul style="list-style-type: none"> <li>• Activating student interest and curiosity</li> <li>• Developing creativity and interpersonal skills and strategies</li> <li>• Exploring diverse possibilities</li> <li>• Forming hypotheses and developing concepts</li> <li>• Solving problems</li> <li>• Drawing inferences</li> </ul>	Students participating in: <ul style="list-style-type: none"> <li>• Discussions</li> <li>• Sharing</li> <li>• Generating alternative ways of thinking and feeling</li> <li>• Decision making</li> <li>• Debates</li> <li>• Role playing</li> <li>• Panels</li> <li>• Brainstorming</li> <li>• Peer conferencing</li> <li>• Collaborative learning groups</li> <li>• Problem solving</li> <li>• Talking circles</li> <li>• Interviewing</li> <li>• Peer editing</li> </ul>	<ul style="list-style-type: none"> <li>• Student motivation and learning increase through active involvement in groups</li> <li>• Teacher's knowledge and skill in forming groups, instructing, and guiding group dynamics are important to the success of this approach</li> <li>• Effective in assisting students' development of life skills in cooperation and collaboration</li> </ul>
<b>Experiential Learning</b>	<ul style="list-style-type: none"> <li>• Student-centred</li> <li>• Teacher may wish to design the order and steps of the process</li> </ul>	<ul style="list-style-type: none"> <li>• Focussing on processes of learning rather than products</li> <li>• Developing students' knowledge and experience</li> <li>• Preparing students for direct instruction</li> </ul>	Students participating in: <ul style="list-style-type: none"> <li>• Activities</li> <li>• Field trips</li> <li>• Simulations</li> <li>• Primary research</li> <li>• Games</li> <li>• Focussed imaging</li> <li>• Role playing</li> <li>• Surveys</li> <li>• Sharing observations and reflections</li> <li>• Reflecting critically on experiences</li> <li>• Developing hypotheses and generalizations in new situations</li> </ul>	<ul style="list-style-type: none"> <li>• Student understanding and retention increase</li> <li>• Hands-on learning may require additional resources and time</li> </ul>
<b>Independent Study</b>	<ul style="list-style-type: none"> <li>• Student-centred</li> <li>• Teacher guides or supervises students' independent study, teaches knowledge, skills, and strategies that students require for independent learning, and provides adequate practice</li> </ul>	<ul style="list-style-type: none"> <li>• Accessing and developing student initiative</li> <li>• Developing student responsibility</li> <li>• Developing self-reliance and independence</li> </ul>	Students participating in: <ul style="list-style-type: none"> <li>• Inquiry and research projects</li> <li>• Using a variety of approaches and methods</li> <li>• Computer-assisted instruction</li> <li>• Essays and reports</li> <li>• Study guides</li> <li>• Learning contracts</li> <li>• Homework</li> <li>• Learning centres</li> </ul>	<ul style="list-style-type: none"> <li>• Students grow as independent, lifelong learners</li> <li>• Student maturity, knowledge, skills and strategies are important to success</li> <li>• Student access to resources is essential</li> <li>• Approach may be used flexibly (it may be used with individual students while other students use other approaches)</li> </ul>

### ***Phases of Learning***

When preparing instructional plans and goals, many teachers find it helpful to consider three learning phases:

- activating (preparing for learning);
- acquiring (integrating and processing learning); and
- applying (consolidating learning).

These phases are not entirely linear but are a useful way of thinking and planning. A variety of activating, acquiring, and applying strategies are discussed in *Success for All Learners: A Handbook on Differentiating Instruction* (Manitoba Education and Training, 1996).

### **Activating (Preparing for Learning)**

One of the strongest indications of how well students will comprehend new information is their prior knowledge of the subject. Some educators observe that more student learning occurs during this phase than at any other time. In planning instruction and assessment, teachers develop student learning experiences and select strategies for activating their students' prior knowledge. Using these activating strategies, the learning experiences then provide information about the extent of students' prior knowledge of the topic to be studied, their knowledge of and familiarity with the context in which that knowledge was acquired, and their knowledge of and proficiency in applying skills for learning.

Learning experiences that draw on students' prior knowledge:

- help students relate new information, skills, and strategies to what they already know and can do (e.g., if a text includes unfamiliar vocabulary, students may not recognize the connection between what they know and the new material being presented);
- allow teachers to recognize misconceptions that might make learning difficult for students;
- allow teachers to augment and strengthen students' knowledge base when students do not possess adequate prior knowledge and experience to engage with new information and ideas;
- help students recognize gaps in their knowledge; and
- stimulate curiosity and initiate the inquiry process that will direct learning.

### **Acquiring (Integrating and Processing Learning)**

In the second phase of learning, students engage with new information and integrate it with what they already know, adding to and revising their previous knowledge. Part of the teacher's role in this phase is to present this new information or to help students access it from various resources.

Since learning is an internal process, however, facilitating learning requires more of teachers than simply presenting information. In the acquiring phase, teachers instruct students in strategies that help them make meaning of information, integrate it with what they already know, and express their new understanding. In addition, teachers monitor these processes to ensure that learning is taking place, using a variety of instruments, tools, and strategies such as observations, conferences, and examination of student work.

In practice, within an actual lesson or unit, the acquiring phase of learning may include a series of steps and strategies, such as:

- setting the purpose (e.g., discrepant events, lesson overviews, learning logs, admit slips);
- presenting information (e.g., lab demonstrations, guest speakers, mini-lessons, active reading);
- processing information (e.g., note making, group discussions, journals, visual representations);
- modelling (e.g., role-playing, demonstrations); and
- checking for understanding (e.g., quizzes, informal conferences).

### **Applying (Consolidating Learning)**

New learning that is not reinforced is soon forgotten. The products and performances by which students demonstrate new learning are not simply required for assessment; they have an essential instructional purpose in providing students with opportunities to demonstrate and consolidate their new knowledge, skills and strategies, and attitudes. Students also need opportunities to reflect on what they have learned and to consider how new learning applies to new situations. By restructuring information, expressing new ideas in another form, or integrating what they have learned in science with concepts from other subject areas, students strengthen and extend learning.

To ensure that students consolidate new learning, teachers plan various learning experiences involving:

- reflection (e.g., journals, exit slips);
- closure (e.g., sharing of products, debriefing on processes); and
- application (e.g., inquiry, design process).

## Differentiating Instruction

How can Senior Years science teachers meet each student's learning requirements and still make learning experiences challenging and meaningful for all? One way to help all students achieve the prescribed student learning outcomes is to differentiate the instructional strategies. Senior 3 Physics makes reference to a variety of field-validated strategies for differentiating instruction. Most have been taken from the support document *Senior Years Science Teachers' Handbook* (Manitoba Education and Training, 1997).

Through differentiating instruction, teachers can:

- activate students' prior knowledge;
- accommodate multiple intelligences and the variety of learning and thinking approaches;
- help students interpret, apply, and integrate information;
- facilitate the transfer of knowledge, skills, and attitudes to students' daily lives; and
- challenge students to realize academic and personal progress and achievement.

Differentiating instruction does not mean offering different programming to each student. Classroom experiences can be differentiated by offering students choices and by varying instructional and assessment strategies to provide challenging and effective learning experiences for all.

## Promoting Strategic Learning

Many of the tasks science students perform are problem-solving tasks, such as finding sources of information for an inquiry project, making meaning of a difficult text, or organizing a body of information. To solve problems, students require a strategic mindset; when confronted with a problem, students survey a number of possible strategies, select the one that seems likely to work best for the situation, and try an alternative method if the first one does not produce results.

Strategic learners in the sciences need to have not only a strategic mindset, but also a repertoire of strategies for making meaning, for processing information, and for expressing ideas and information effectively. Whereas skills are largely unconscious mental processes that learners use in accomplishing learning tasks, strategies are systematic and conscious plans, actions, and thoughts that learners select or invent and adapt to each task. Strategies are often described as "knowing what to do, how to do it, when to do it, and why it is useful."

---

**Differentiating Instruction:** Adapted from *Success for All Learners: A Handbook on Differentiating Instruction*. Copyright © 1996 by Manitoba Education and Training. All rights reserved.

### **Scaffolding: Supporting Students in Strategic Learning**

Many scientific tasks involve a complex interaction of skills. The most effective way to learn, however, is not by breaking down the tasks into manageable parts and teaching the skills separately and in isolation. In fact, this approach may be counterproductive. Purcell-Gates (1996) uses the analogy of learning to ride a bicycle, a skill that requires children to develop an intuitive sense of balance while also learning to pedal and steer. Children do not learn to ride a bicycle by focussing on only one of these skills at a time. Instead, they observe others who can ride a bicycle successfully, and then make an attempt themselves. In the early stages of learning to ride, a child counts on someone to provide support—to hold the bicycle upright while the child mounts, to keep a hand on the seat to stabilize the bicycle for the first few metres, and to coach and encourage. Gradually, these supports are withdrawn as the rider becomes more competent. Eventually, the process becomes automatic, and the rider is no longer aware of the skills being performed.

Providing this sort of support in teaching is called “scaffolding,” based on the work of Wood, Bruner, and Ross (1976). Teachers scaffold by:

- structuring tasks so that learners begin with something they can do;
- reducing the complexity of tasks;
- calling students’ attention to critical features of the tasks;
- modelling steps; and
- providing sufficient guided and independent practice.

In a sense, each learning strategy is an external support or scaffold. At first, working with a new strategy may be challenging and the main focus of students’ attention. Eventually, students use the strategy automatically and rely on it as a learning tool. Students gradually internalize the process of the strategy. They begin to adjust and personalize the process and to apply the thinking behind the strategy automatically.

In strategic instruction, teachers observe and monitor students’ use of a strategy for a time, intervening where necessary. Students vary in the length of time they require scaffolding. In this respect, strategic instruction is also a useful tool for differentiation. Struggling learners may work with simplified versions of a strategy, and they may continue to use the supports of a strategy (for example, a graphic organizer for laboratory reports) after other students have internalized the process.

Strategic instruction works best when teachers pace the instruction of new strategies carefully (so that students have time to practise each one), and when they teach a strategy in the context of a specific task of relevant scientific experience.

## Instructional Strategies

The following outlines instructional strategies that may be used with Senior 3 Physics. The strategies are referenced in the Suggestions for Instruction column of this document.

- **Journal Writing**

- Science journal writing allows students to explore and record various aspects of their experiences in science class. By sorting out their thoughts on paper or thinking about their learning (metacognition), students are better able to process what they are learning.

- **Class Discussion**

- Discussions may be used in a variety of ways. They may spark interest in a topic or learning outcome, activate prior knowledge by inviting speculation on why certain events occur, or generate ideas for solutions to problems.

- **Prior Knowledge Activities**

- Students learn best when they are able to relate new knowledge to what they already know. Brainstorming, KWL charts, and Listen-Think-Pair-Share (see *Senior Years Science Teachers' Handbook*) are just a few of the strategies that may be used to activate and assess students' prior knowledge.

- **Student Research/Reports**

- Learning projects that involve student research are one of the most effective ways to individualize instruction in a diverse classroom. These learning activities provide students with the opportunity to develop their research skills as they gather, process, and evaluate information.

- **Teacher/Student Demonstration**

- Demonstrations, such as discrepant events, may be used to arouse student interest and allow for visualization of phenomena. Demonstrations can activate prior knowledge and generate discussion about learning outcomes.

- **Visual Displays**

- When students create visual displays, they make their thinking visible. Generating diagrams, posters, or models provides students with the opportunity to represent abstract information in a more concrete form.

- **Collaborative Teamwork**

- Instructional strategies, such as the Jigsaw or Roundtable (see *Senior Years Science Teachers' Handbook*), encourage students to learn from one another and to develop teamwork skills. The use of cooperative learning activities may lead to increased understanding of content and improved thinking skills.

- **Laboratory Activities**

- Laboratory activities, whether student- or teacher-designed, provide students with the opportunity to apply their scientific knowledge and skills related to a group of learning outcomes. Students appreciate the hands-on experience of doing science.

- **Debates**

- Debates draw upon students' own positions on STSE issues. When carefully structured, debates may be used to encourage students' consideration of societal concerns and the opinions of others, and to improve their communication and research skills.

- **Community Connection**

- Field trips and guest speakers may provide students with the opportunity to see science applied in their community and local natural environments.

- **Webquests**

- A Webquest is an inquiry-oriented activity in which most or all the information used by learners comes from resources on the Internet. Webquests are designed to use learners' time well, to focus on using information rather than looking for it, and to support learners' thinking at the levels of analysis, synthesis, and evaluation.

- **Problem-Based Learning (PBL)**

- PBL is a curricular design that centres on an authentic problem. Students are assigned roles and presented with a problem that has no single, clear-cut solution. Students acquire content knowledge as they work toward solving the problem.

---

## ***SECTION 3***

Characteristics of Effective Assessment 4

Types of Assessment 10

Assessment Strategies 11

---



## ASSESSMENT IN SENIOR 3 PHYSICS

Classroom assessment is an integral part of science instruction. Assessment could be described as the systematic process of gathering information about what a student knows, is able to do, and is learning to do. The primary purpose of classroom assessment is not to evaluate and classify student performance, but to inform teaching and improve learning, and to monitor student progress in achieving year-end learning outcomes.

Rather than emphasizing the recall of specific, detailed and unrelated 'facts', [assessment in science] should give greater weight to an assessment of a holistic understanding of the major scientific ideas and a critical understanding of science and scientific reasoning (Millar and Osborne, eds., 1998).

Classroom assessment is broadly defined as any activity or experience that provides information about student learning. Teachers learn about student progress not only through formal tests, examinations, and projects, but also through moment-by-moment observation of students in action. They often conduct assessment through instructional activities.

Much of students' learning is internal. To assess students' science knowledge, skills and strategies, and attitudes, teachers require a variety of tools and approaches. They ask questions, observe students engaged in a variety of learning activities and processes, and examine student work in progress. They also engage students in peer-assessment and self-assessment activities. The information that teachers and students gain from assessment activities informs and shapes what happens in the classroom; assessment always implies that some action will follow.

To determine whether student learning outcomes have been achieved, student assessment must be an integrated part of teaching and learning. Assessment of student learning involves careful planning and systematic implementation.

### Planning for Assessment

Assessment purposes, approaches, and tools should be developed with instructional approaches during the planning of the unit. In developing assessment tasks and methods, teachers determine:

- what they are assessing;
- why they are assessing;
- how the assessment information will be used;
- who will receive the assessment information; and
- what assessment activities or tasks will allow students to demonstrate their learning in authentic ways.

## Characteristics of Effective Assessment

Effective assessment helps focus effort on implementing strategies to facilitate learning both inside and outside the classroom, and demonstrates the following characteristics:

- congruent with instruction, and integral to it;
- ongoing and continuous;
- based on authentic tasks and meaningful science-learning processes and contexts;
- based on criteria that students know and understand, appealing to their strengths;
- a collaborative process involving students;
- multi-dimensional, and uses a wide range of tools and methods; and
- focussed on what students have learned and can do.

## Effective Assessment Is Congruent with (and Integral to) Instruction

Assessment requires teachers to be aware continually of the purpose of instruction: What do I want my students to learn? What can they do to show that they have learned it?

How teachers assess depends on what they are assessing—whether they are assessing declarative knowledge, procedural knowledge, or attitudes and habits of mind.

- **DECLARATIVE KNOWLEDGE:** If teachers wish to measure fact-based recall, declarative knowledge is the most straightforward dimension of learning to measure using traditional tools. The purpose of fostering scientific literacy, however, is not met if students simply memorize the declarative knowledge related to science; what is more important is whether students understand and are able to apply this knowledge. For example, it is more important that they understand the purposes and effects of biodiversity, that they respond to and interpret what biodiversity means for them personally and environmentally, and that they use terminology with ease to enrich their scientific communication skills, and represent—rather than reproduce—a definition of biodiversity. The challenge teachers face is to design tools that test the application of declarative knowledge.
- **PROCEDURAL KNOWLEDGE:** Tools that are designed to test declarative knowledge cannot effectively assess skills and processes. For example, rather than trying to infer student processes by looking at final products, teachers assess procedural knowledge by observing students in action, by discussing their strategies with them in conferences and interviews, and by gathering data from student reflections such as journals.

---

**Characteristics of Effective Assessment:** Adapted from *Senior 3 English Language Arts: A Foundation for Implementation*. Copyright © 1999 by Manitoba Education and Training. All rights reserved.

- **ATTITUDES AND HABITS OF MIND:** Attitudes and habits of mind cannot be assessed directly. They are implicit in what students do and say. Assessment tools typically describe the behaviours that reflect the attitudes and habits of scientifically literate individuals. They identify the attitudes and habits of mind that enhance science-related language learning and use, and provide students with the means to reflect on their own internal processes. For example, rather than assigning global marks for class participation, teachers assess learning outcomes related to students' effective contributions to large and small groups.

Assessment is intended to inform students of the programming emphases and to help them focus on important aspects of learning. If teachers assess only the elements that are easiest to measure, students may focus only on those things. For example, if science courses place a high value on collaboration, creativity, and divergent thinking (learning outcomes that may be more difficult to measure), then assessment tools and processes must reflect those values. The ways teachers assess (what and how) inform students of what is considered important in learning.

### **Effective Assessment Is Ongoing and Continuous**

Assessment that is woven into daily instruction offers students frequent opportunities to gain feedback, to modify their learning approaches and methods, and to observe their progress. Teachers provide informal assessment by questioning students and offering comments. They also conduct formal assessments at various stages of a project or unit of study.

Continuous assessment provides ongoing opportunities for teachers to review and revise instruction, content, process emphases, and learning resources.

### **Effective Assessment Is Based on Authentic Tasks and Meaningful Science Learning Processes and Contexts**

Assessment tasks in science should be authentic and meaningful—tasks worth mastering for their own sake rather than tasks designed simply to demonstrate student proficiency for teachers and others. Through assessment, teachers discover whether students can use knowledge, processes, and resources effectively to achieve worthwhile purposes. Therefore, teachers design tasks that replicate the context in which knowledge will be applied in the world beyond the classroom.

For example, authentic science writing tasks employ the forms used by a wide range of people (for example, scientists, journalists, filmmakers, poets, novelists, publicists, speakers, technical writers, engineers, and academics). As often as possible, students write, speak, or represent their ideas for real audiences and for real purposes. In developing assessment tasks, teachers may consider providing students with the resources people use when performing the same tasks in real-life situations related to issues in science.

Authentic assessment tasks are not only tests of the information students possess, but also of the way their understanding of a subject has deepened, and of their ability to apply learning. They demonstrate to students the relevance and importance of learning. Performance-based tests are also a way of consolidating student learning. The perennial problem teachers have with “teaching to the test” is of less concern if tests are authentic assessments of student knowledge, skills and strategies, and attitudes.

### **Effective Assessment Is Based on Criteria that Students Know and Understand, Appealing to Their Strengths**

Assessment criteria must be clearly established and made explicit to students before an assignment or test so students can focus their efforts. In addition, whenever possible, students need to be involved in developing assessment criteria. Appendix 5 includes a process for creating assessment rubrics in collaboration with students.

Students should also understand clearly what successful accomplishment of each proposed task looks like. Models of student work from previous years and other exemplars assist students in developing personal learning goals.

Each assessment task should test only those learning outcomes that have been identified to students. This means, for example, that laboratory skills tests need to be devised and marked to gather information about students’ laboratory skills, not their ability to express ideas effectively when writing a laboratory report.

### **Effective Assessment Is a Collaborative Process Involving Students**

The ultimate purpose of assessment is to enable students to assess *themselves*. The gradual increase of student responsibility for assessment is aimed at developing students’ autonomy as lifelong learners. Assessment should decrease, rather than foster, students’ dependence on teachers’ comments for direction in learning and on marks for validation of their accomplishments.

Assessment enhances students’ metacognition. It helps them make judgements about their own learning, and provides them with information for goal setting and self-monitoring.

Teachers increase students’ responsibility for assessment by:

- requiring students to select the products and performances to demonstrate their learning;
- involving students in developing assessment criteria whenever possible (This clarifies the goals of a particular assignment and provides students with the vocabulary to discuss their own work.);
- involving students in peer assessment, informally through peer conferences and formally using checklists;
- having students use tools for reflection and self-assessment at every opportunity (e.g., self-assessment checklists, journals, identification and selection of goals, and self-assessment of portfolio items); and

- establishing a protocol for students who wish to challenge a teacher-assigned mark. (Formal appeals are valuable exercises in persuasive writing, and provide opportunities for students to examine their performance in light of the assessment criteria.)

### Effective Assessment Is Multi-Dimensional and Uses a Wide Range of Tools and Methods

Assessment in science must recognize the complexity and holistic nature of learning for scientific literacy. To compile a complete profile of each student's progress, teachers gather data using many different means over numerous occasions. Student profiles may involve both students and teachers in data gathering and assessment.

The following chart identifies areas for assessment and some suggested assessment instruments, tools, and methods.

Data-Gathering Profile			
Observation of Processes		Observation of Products and Performances	
Teacher <ul style="list-style-type: none"> <li>• checklists</li> <li>• conferences and interviews</li> <li>• anecdotal comments and records</li> <li>• reviews of drafts and revisions</li> <li>• oral presentations</li> <li>• rubrics and marking scales</li> </ul>	Students: <ul style="list-style-type: none"> <li>• journals</li> <li>• self-assessment instruments and tools (e.g., checklists, rating scales, progress charts)</li> <li>• peer-assessment instruments and tools (e.g., peer conference records, rating scales)</li> </ul>	Teacher: <ul style="list-style-type: none"> <li>• written assignments</li> <li>• demonstrations</li> <li>• presentations</li> <li>• seminars</li> <li>• projects</li> <li>• portfolios</li> <li>• student journals and notebooks</li> <li>• checklists</li> <li>• rubrics and marking scales</li> </ul>	Students: <ul style="list-style-type: none"> <li>• journals</li> <li>• self-assessment instruments and tools</li> <li>• peer-assessment instruments and tools</li> <li>• portfolio analysis</li> </ul>
Classroom Tests		Divisional and Provincial Standards Tests	
Teacher <ul style="list-style-type: none"> <li>• paper-and-pencil tests (e.g., teacher-made tests, unit tests, essay-style tests)</li> <li>• performance tests and simulations</li> <li>• rubrics and marking scales</li> </ul>	Students: <ul style="list-style-type: none"> <li>• journals</li> <li>• self-assessment instruments and tools</li> </ul>	Teacher marker: <ul style="list-style-type: none"> <li>• rubrics and marking scales</li> </ul>	

### **Effective Assessment Focuses on What Students Have Learned and Can Do—Not on What They Have Not Learned or Cannot Do**

Assessment must be equitable; it must offer opportunities for success to every student. Effective assessment demonstrates the knowledge, skills and attitudes, and strategies of each student and the progress the student is making, rather than simply identifying deficits in learning.

To assess what students have learned and can do, teachers need to use a variety of strategies and approaches.

- Use a wide range of instruments to assess the multi-dimensional expressions of each student's learning, avoiding reliance upon rote memorization.
- Provide students with opportunities to learn from feedback and to refine their work, recognizing that not every assignment will be successful nor will it become part of a summative evaluation.
- Examine several pieces of student work in assessing any particular learning outcome to ensure that data collected are valid bases for making generalizations about student learning.
- Develop complete student profiles by using information from both learning outcome-referenced assessment, which compares a student's performance to predetermined criteria, and self-referenced assessment, which compares a student's performance to her or his prior performance.
- Avoid using assessment for purposes of discipline or classroom control. Ryan, Connell, and Deci (1985) found that assessment that is perceived as a tool for controlling student behaviour, meting out rewards and punishments rather than providing feedback on student learning, reduces student motivation.

Students are sometimes assigned a mark of zero for incomplete work. Averaging a zero into the student's mark, however, means the mark no longer communicates accurate information about the student's achievement of science learning outcomes. Unfinished assignments signal personal or motivational problems that need to be addressed in appropriate and alternative ways.

- Allow students, when appropriate and possible, to choose how they will demonstrate their competence.
- Use assessment tools appropriate for assessing individual and unique products, processes, and performances.

### **Managing Classroom Assessment**

Assessment is one of the greatest challenges science teachers face. The practices that make science classrooms vital and effective (promoting student choice, assessing processes, and assessing the subjective aspect of learning) make assessment a complex matter.

Systems and supports that may assist teachers in managing assessment include:

- dispensing with ineffectual means of assessment;
- using time savers;

- sharing the load;
- taking advantage of technology; and
- establishing systems of recording assessment information.

### **Dispensing with Ineffectual Means of Assessment**

Teachers need to question the efficacy, for example, of writing lengthy commentaries on summative assessment of student projects. Detailed comments are best provided as formative assessment, when students can make immediate use of the feedback, and shared orally in conferences, which provide opportunities for student-teacher discussion.

The time spent in assessment needs to be learning time, both for teacher and student.

### **Using Time Savers**

Many effective assessment tools are time savers. Developing checklists and rubrics is time-consuming; however, well-written rubrics may eliminate the need to write extensive comments, and may mean that student performances can be assessed largely during class time.

### **Sharing the Load**

While the ultimate responsibility for assessment rests with the teacher, student self-assessment also provides a wealth of information. Collaborating with students to generate assessment criteria is part of effective instruction. Senior 3 students may develop checklists and keep copies of their own goals in an assessment binder for periodic conferences. Students may be willing to contribute work samples to be used as models with other classes.

Collaborating with other teachers in creating assessment tools saves time and provides opportunities to discuss assessment criteria.

### **Taking Advantage of Technology**

Electronic tools (e.g., audiotapes, videotapes, and computer files) can assist teachers in making and recording observations. Word processors allow teachers to save, modify, and reuse task-specific checklists and rubrics.

### **Establishing Systems for Recording Assessment Information**

Collecting data from student observations is especially challenging for Senior Years teachers, who may teach several classes of students in a given semester or term. Teachers may want to identify a group of students in each class for observation each week. Binders, card files, and electronic databases are useful for record keeping, as are self-stick notes recording brief observations on student files, which can later be transformed into anecdotal reports.

Teachers may also want to develop comprehensive forms for listing the prescribed learning outcomes, and for recording data.

This view of effective assessment in science for Manitoba is reflective of changes in emphases in science education at the national level and is congruent with international changes in science education. The following chart summarizes some of the changes in the area of assessment.

<b>Changing Emphases in Assessment of Student Learning</b>	
The <i>National Science Education Standards</i> envision change throughout the system. The assessment standards encompass the following changes in emphases:	
<b>LESS EMPHASIS ON</b>	<b>MORE EMPHASIS ON</b>
Assessing what is easily measured	<b>Assessing what is most highly valued</b>
Assessing discrete knowledge	<b>Assessing rich, well-structured knowledge</b>
Assessing scientific knowledge	<b>Assessing scientific understanding and reasoning</b>
Assessing to learn what students do not know	<b>Assessing to learn what students do understand</b>
Assessing only achievement	<b>Assessing achievement and opportunity to learn</b>
End-of-term assessments by teachers	<b>Students engaged in ongoing assessment of their work and that of others</b>
Development of external assessment by measurements experts alone	<b>Teachers involved in the development of external assessments</b>

### Types of Assessment

Assessment can be formative, summative, or diagnostic.

- **Formative assessment** is given during the instructional unit and provides students and teachers with information about students' progress in accomplishing prescribed learning outcomes. Formative assessment also evaluates the effectiveness of instructional programming content, methods, sequence, and pace.
- **Summative assessment** (evaluation) is based on an interpretation of the assessment information collected and is given at the end of an instructional unit. It helps determine the extent of each student's achievement of prescribed learning outcomes. Evaluation should be based on a variety of assessment information. Summative assessment is used primarily to measure student achievement, to report to parent(s) or guardian(s), students, and other stakeholders, or measure the effectiveness of instructional programming.
- **Diagnostic Assessment** is given before instruction and determines student understanding of topics before learning takes place.

---

**Changing Emphases in Assessment of Student Learning:** Reprinted with permission from *National Science Education Standards*. Copyright © 1996 by the National Academy of Sciences. Courtesy of the National Academies Press. Washington, DC.



## **Assessment Strategies**

Senior 3 Physics suggests a range of assessment strategies. The same strategy can be used both for formative and summative assessment, depending on the purpose of the assessment. Suggested assessment strategies that can be used in the science classroom are discussed in detail in the following section. Teachers are encouraged to develop their own assessment for Senior Years science based on their students' learning requirements and the prescribed student learning outcomes.

- **Observation**

Observation of students is an integral part of the assessment process. It is most effective when focussed on skills, concepts, and attitudes. Making brief notes on index cards, self-stick notes, or grids, as well as keeping checklists, helps teachers maintain records of continuous progress and achievement.

- **Interviews**

Interviews allow teachers to assess an individual's understanding and achievement of the prescribed student learning outcome(s). Interviews provide students with opportunities to model and explain their understandings. Interviews may be both formal and informal. Posing science-related questions during planned interviews enables teachers to focus on individual student skills and attitudes. Students reveal their thinking processes and use of skills when they are questioned about how they solved problems or answered science questions. Using a prepared set of questions ensures that all interviews follow a similar structure. It is important to keep a record of student responses and/or understandings.

- **Group/Peer Assessment**

Group assessment gives students opportunities to assess how well they work within a group. Peer assessment gives them opportunities to reflect on one another's work, according to clearly established criteria. During the peer assessment process, students must reflect on their own understanding in order to evaluate the performance of another student.

- **Self-Assessment**

Self-assessment is vital to all learning and, therefore, integral to the assessment process. Each student should be encouraged to assess her or his own work. Students apply known criteria and expectations to their work and reflect on results to determine their progress toward the mastery of a prescribed learning outcome. Participation in setting self-assessment criteria and expectations helps students to see themselves as scientists and problem solvers. It is important that teachers model the self-assessment process before expecting students to assess themselves.

- **Performance Assessment/Student Demonstration**

Performance tasks provide students with opportunities to demonstrate their knowledge, thinking processes, and skill development. The tasks require the application of knowledge and skills related to a group of student learning outcomes. Performance-based tests do not test the information that students possess, but the way their understanding of a subject has been deepened, and their ability to apply their learning in a simulated performance. A scoring rubric that includes a scale for the performance of the task helps organize and interpret evidence. Rubrics allow for a continuum of performance levels associated with the task being assessed.

- **Science Journal Entries**

Science journal writing provides opportunities for students to reflect on their learning and to demonstrate their understanding using pictures, labelled drawings, and words. These journal entries can be powerful tools of formative assessment, allowing teachers to gauge a student's depth of understanding.

- **Rubrics/Checklists**

Rubrics and checklists are tools that identify the criteria upon which student processes, performances, or products will be assessed. They also describe the qualities of work at various levels of proficiency for each criterion. Rubrics and checklists may be developed in collaboration with students.

- **Visual Displays**

When students or student groups prepare visual displays, they are involved in processing information and producing a knowledge framework. The completed poster, concept map, diagram, model, et cetera, is the product with which teachers can determine what their students are thinking.

- **Laboratory Reports**

Laboratory reports allow teachers to gauge the ability of students to observe, record, and interpret experimental results. These tools can aid teachers in determining how well students understand the content.

- **Pencil-and-Paper Tasks**

Quizzes can be used as discrete assessment tools, and tests can be larger assessment experiences. These written tasks may include items such as multiple-choice questions, completion of a drawing or labelled diagram, problem solving, or long-answer questions. Ensure that both restricted and extended expository responses are included in these assessment devices.

- **Research Report/Presentation**

Research projects allow students to reach the learning outcomes in individual ways. Assessment should be built into the project at every stage, from planning to researching to presenting the finished product.

- **Interpretation of Media Reports of Science**

Short pieces extracted from newspapers could be used to assess the following: whether pupils understand the scientific content of the piece; whether they can identify and evaluate the possible risks and quality of the evidence presented; whether they can offer well-thought-out reactions to the claims; and, finally, whether they can give their opinion about future action that could be taken by individuals, government, or other bodies (Millar and Osborne, 1998, p. 26).

- **Demonstration of an Understanding of the Major Explanatory Stories of Science**

Questions should seek to examine observable results such as the following: whether students have understood what the particle model of matter is; whether they can give a short account of it; whether they can use it to explain everyday phenomena; and whether they can explain why it is an important idea in science (Millar and Osborne, 1998, p. 26).

- **Asking and Answering Questions Based on Data**

Such questions should assess students' abilities to represent data in a variety of ways; to formulate and interpret the messages that can be extracted from data; and to detect errors and dishonesty in the way data are presented or selected. The ability to manipulate and interpret data is a core skill that is of value, not only in science, but also in a wide range of other professions and contexts (Millar and Osborne, 1998, p. 26).

- **Recognizing the Role of Evidence**

At the heart of scientific rationality is a commitment to evidence. Contemporary science confronts the modern citizen with claims that are contested and uncertain. Questions based on historical or contemporary examples can be used to investigate students' understanding of the role of evidence in resolving competing arguments between differing theoretical accounts (Millar and Osborne, 1998, p. 26).

## NOTES

---

## ***SECTION 4***

Guide to Reading Specific Learning Outcomes and Document Format	3
Document Format	4
Guide to Reading Specific Learning Outcomes	6
Overview	7

---

## DOCUMENT ORGANIZATION

The prescribed learning outcomes and the suggestions for instruction, assessment, and learning resources contained within *Senior 3 Physics: A Foundation for Implementation* provide teacher educators with a plan for achieving the student learning outcomes. The document is organized by topics; Cluster 0: Skills and Attitudes is followed by the four “thematic” topics. In addition, the appendices comprise Student Learning Activities, Teacher Support Materials, and Blackline Masters. These complementary materials are designed to support, facilitate, and enhance student learning and assessment by being closely linked to the learning outcomes and the skills and attitudes.

### Guide to Reading the Specific Learning Outcomes and the Document Format

- The **Prescribed Learning Outcomes** identified in the header outline the intended learning to be achieved by the student by the end of the course. They include the specific learning outcomes related to the thematic topic in addition to the learning outcomes related to Cluster 0: Skills and Attitudes, selected to correspond to the Suggestions for Instruction.
- the **Suggestions for Instruction** directly relate to the achievement of the specific learning outcomes contained in the header at the top of each page.
- the **Suggestions for Assessment** of the specific learning outcomes offer assistance in identifying appropriate strategies.
- the **Suggested Learning Resources** are intended to guide and support instruction, the learning process, and student assessment.
- Teacher Notes boxes provide for hand-written planning hints, special interest material, and depth of treatment on certain issues related to the learning outcomes. These are incorporated as text boxes throughout.

The pages that follow provide detailed clarification on reading the document format.

Document Format

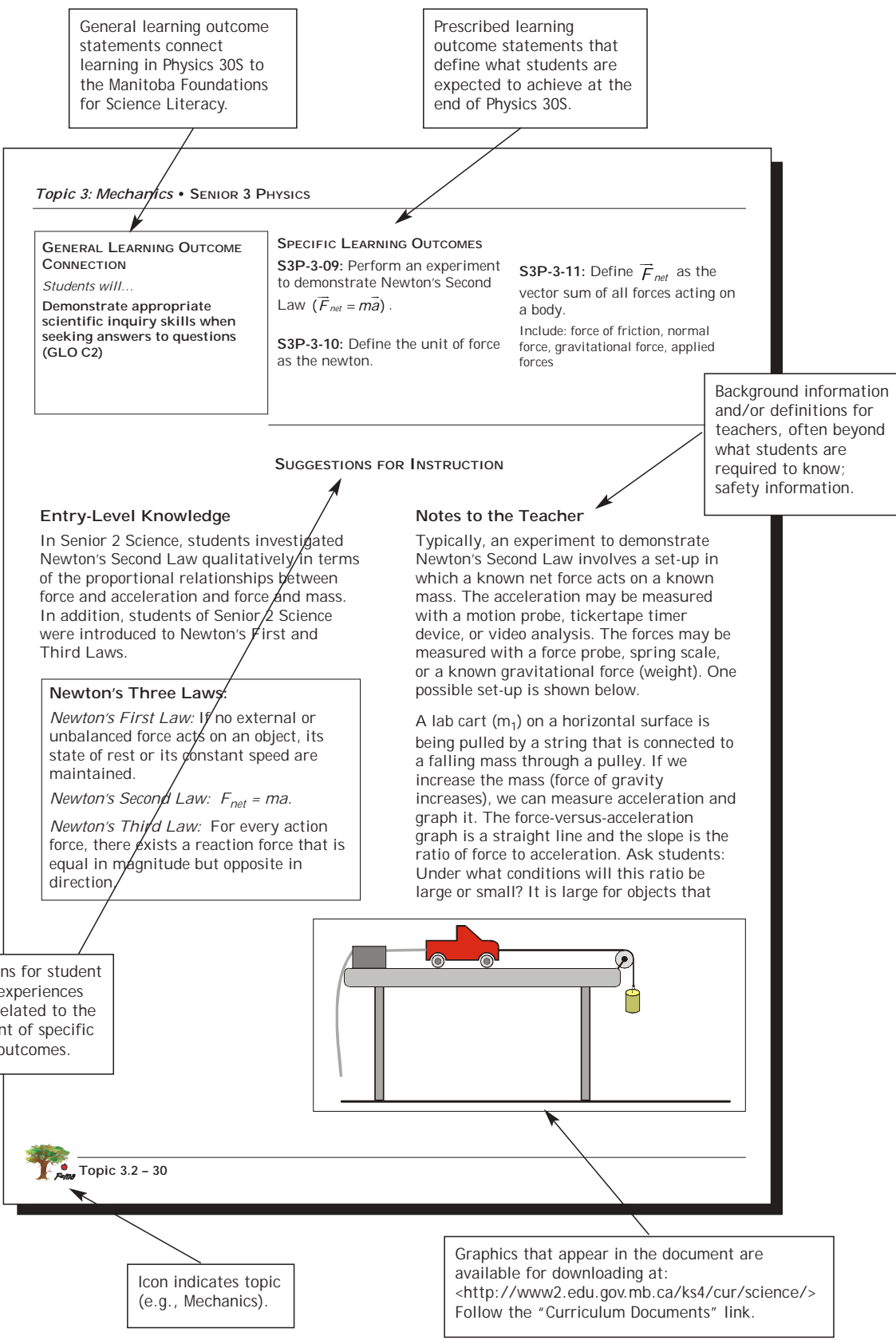

Skills and attitudes learning outcomes define expectations across all topics in Physics 30S.

SENIOR 3 PHYSICS • *Topic 3: Mechanics*

---

<p><b>SKILLS AND ATTITUDES OUTCOMES</b></p> <p>S3P-0-2h: Analyze problems, using vectors. Include: adding and subtracting vectors in straight lines and at right angles, vector components</p> <p>S3P-0-2b: Propose problems, state hypotheses, and plan, implement, adapt, or extend procedures to carry out an investigation where required.</p>	<p>SS3P-0-4b: Work cooperatively with a group to identify prior knowledge, initiate and exchange ideas, propose problems and their solutions, and carry out investigations.</p> <p>S3P-0-4c: Demonstrate confidence in carrying out scientific investigations and in addressing STSE issues.</p>
--	--

**GENERAL LEARNING OUTCOME CONNECTION**  
*Students will...*  
**Understand how stability, motion, forces, and energy transfers and transformations play a role in a wide range of natural and constructed contexts (GLO D4)**

---

<b>SUGGESTIONS FOR INSTRUCTION</b>	<b>SUGGESTIONS FOR ASSESSMENT</b>
<p>are difficult to accelerate, and small for objects that are easy to accelerate. This resistance to acceleration is called the inertial mass of the object.</p> <p>The relationship between <math>F_{net}</math> and acceleration can also be demonstrated in a lab, using dynamic carts on an inclined plane. As the angle of the incline increases, the force acting on the cart also increases according to <math>\sin\theta</math>.</p> <p><math>F = ma</math> defines force. The SI units for force can be derived from this equation. Therefore, a unit of force is a <math>\text{kg}\cdot\text{m}/\text{s}^2</math>, and is given the name newton (N).</p> <p><b>Note:</b> The <math>F</math> in <math>F = ma</math> is the net force acting on the mass and should always be written as:</p> <p><math>F_{net} = ma</math>, where <math>F_{net}</math> = sum of the applied forces.</p> <p>OR</p> <p><math>\Sigma \vec{F} = ma</math>, where <math>\Sigma \vec{F}</math> = sum of the applied forces.</p>	<p>Students submit a lab report that states the relationship among force, mass, and acceleration, and some systemic errors (specific to this lab) that could be redesigned to improve future trials.</p> <div style="border: 1px solid black; padding: 5px; margin-top: 10px;"> <p style="text-align: center;"><b>SUGGESTED LEARNING RESOURCES</b></p> <p>Appendix 3.15: Journal Entry: Dynamics and Diagrams</p> <p>Appendix 3.16: Free-Body Diagrams: Linear Motion</p> <p>Appendix 3.17: Free-Body Diagrams 2: Linear Motion</p> </div>

Topic 3.2 – 31

Suggestions for assessing specific learning outcomes.

Suggestions for learning resources, including print and information technology resources.



**Guide to Reading Specific Learning Outcomes**

*Topic 4: Fields • SENIOR 3 PHYSICS*

<p><b>GENERAL LEARNING OUTCOME CONNECTION</b>  <i>Students will...</i>                  Identify and appreciate contributions made by women and men from many societies and cultural backgrounds towards increasing our understanding of the world and in bringing about technological innovations (GLO A4)</p>	<p><b>SPECIFIC LEARNING OUTCOMES</b></p> <p><b>S3P-4-18:</b> Describe a simplified version of Millikan's experiment for the determination of the elementary charge (solve for charge when <math>F_e = F_g</math>).</p> <p><b>S3P-4-19:</b> Define the elementary charge and convert between elementary charges and coulombs.                  Include: <math>q = Ne</math></p>	
---	--	--

**SUGGESTIONS FOR INSTRUCTION**

**Notes to the Teacher**

Millikan's experiment can be diagrammed and described, or demonstrated using animations.

Define the elementary charge. Convert between elementary charges and coulombs. The coulomb is actually defined operationally by the force of attraction between two current-carrying wires. However, at this point, introduce the coulomb as a fixed number of elementary charges (1C =  $6.25 \times 10^{18}$  elementary charges). Therefore, in coulombs, one elementary charge is:

$$q = N \times e$$

$$1 \text{ C} = 6.25 \times 10^{18} e$$

and

$$e = \frac{1}{6.25 \times 10^{18}} \text{ C}$$

$$e = 1.6 \times 10^{-19} \text{ C}$$

An elementary charge is the charge of an electron ( $-e$ ) or a proton ( $+p$ ).

Solve for the quantity of charge ( $q$ ), electric force ( $F_e$ ), mass, gravitational force ( $F_g$ ), number and type (proton/electrons) of elementary charge ( $N$ ) for Millikan-type problems.

In terms of Newton's Second Law, for a small sphere placed between the plates, we have:

$$F_{\text{net}} = F_{\text{applied}} + F_{\text{friction}}$$

such that

$$F_{\text{friction}} = 0 \text{ (negligible) and}$$

$$F_{\text{applied}} = F_e + F_g$$

There are several cases to address for charges between parallel plates:

$F_e = -F_g$  (the sphere is stationary between the plates)

$F_e < F_g$  (opposite to  $F_e$ , such that  $a < g$ )



**SPECIFIC LEARNING OUTCOMES**

**S3P-4-18:** Describe a simplified version of Millikan's experiment for the determination of the elementary charge (solve for charge when  $F_e = F_g$ ).

**S3P-4-19:** Define the elementary charge and convert between elementary charges and coulombs.  
 Include:  $q = Ne$

First alphanumeric indicates course (Senior 3 Physics); second digit indicates topic number; third digit(s) indicates specific learning outcome number

Examples: Provide ideas of what could be included (non-mandatory).  
*None given in this outcome.*

Include: Indicates a mandatory component of the specific learning outcome.

## Skills and Attitudes Outcomes Overview

Cluster 0 in Physics 30S comprises four categories of specific learning outcomes that describe the skills and attitudes\* involved in scientific inquiry and the decision-making process for STSE issues. In Grades 5 to Senior 2, students develop scientific inquiry through the development of an hypothesis/prediction, the identification and treatment of variables, and the formation of conclusions. Students begin to make decisions based on scientific facts and refine their decision-making skills as they progress through the grades, gradually becoming more independent. Students also acquire key attitudes, an initial awareness of the nature of science, and other skills related to research, communication, the use of information technology, and cooperative learning.

In Senior 3 Physics, students continue to use scientific inquiry as an important process in their science learning, but also recognize that STSE issues require a more sophisticated treatment through the decision-making process.

Teachers should select appropriate contexts to introduce and reinforce scientific inquiry, the decision-making process, and positive attitudes within the thematic topics 1 to 4 throughout the school year. For example, students could use the decision-making process as they examine an STSE issue related to sound in Topic 1. To assist in planning and to facilitate curricular integration, many specific learning outcomes within the Skills and Attitudes cluster can link to specific learning outcomes in other subject areas, specifically English Language Arts (ELA) and Mathematics (Math).

### Nature of Science

- S3P-0-1a Explain the roles of theory, evidence, and models in the development of scientific knowledge.
- S3P-0-1b Describe the importance of peer review in the evaluation and acceptance of scientific theories, evidence, and knowledge claims.
- S3P-0-1c Relate the historical development of scientific ideas and technology to the form and function of scientific knowledge today.
- S3P-0-1d Describe how scientific knowledge changes as new evidence emerges and/or new ideas and interpretations are advanced.
- S3P-0-1e Differentiate between how scientific theories explain natural phenomena and how scientific laws identify regularities and patterns in nature.

---

\* Cluster 0: Overall Skills and Attitudes—specific learning outcomes for this grade/course are presented as a chart (separate attachment). The purpose of this chart is to provide a full course overview of skills and attitudes that need to be achieved.

### **Inquiry Skills**

- S3P-0-2a Select and use appropriate visual, numeric, graphical, and symbolic modes of representation to identify and represent relationships.
- S3P-0-2b Propose problems, state hypotheses, and plan, implement, adapt, or extend procedures to carry out an investigation where required.
- S3P-0-2c Formulate operational definitions of major variables or concepts.
- S3P-0-2d Estimate and measure accurately, using Système International (SI) units.
- S3P-0-2e Evaluate the relevance, reliability, and adequacy of data and data-collection methods.  
Include: discrepancies in data and sources of error
- S3P-0-2f Record, organize, and display data, using an appropriate format.  
Include: labelled diagrams, tables, graphs.
- S3P-0-2g Interpret patterns and trends in data, and infer or calculate linear relationships among variables.
- S3P-0-2h Analyze problems, using vectors.  
Include: adding and subtracting vectors in straight lines and at right angles, vector components
- S3P-0-2i Select and integrate information obtained from a variety of sources.  
Include: print, electronic, and/or specialist sources, resource people.

### **Science, Technology, Society, and the Environment (STSE)**

- S3P-0-3a Analyze, from a variety of perspectives, the risks and benefits to society and the environment when applying scientific knowledge or introducing technology.
- S3P-0-3b Describe examples of how technology has evolved in response to scientific advances, and how scientific knowledge has evolved as a result of new innovations in technology.
- S3P-0-3c Identify social issues related to science and technology, taking into account human and environmental needs and ethical considerations.
- S3P-0-3d Use the decision-making process to address an STSE issue.
- S3P-0-3e Identify a problem, initiate research, and design a technological or other solution to address the problem.

**Attitudes**

- S3P-0-4a Demonstrate work habits that ensure personal safety, the safety of others, and consideration of the environment.
- S3P-0-4b Work cooperatively with a group to identify prior knowledge, initiate and exchange ideas, propose problems and their solutions, and carry out investigations.
- S3P-0-4c Demonstrate confidence in carrying out scientific investigations and in addressing STSE issues.
- S3P-0-4d Develop a sense of personal and shared responsibility for the impact of humans on the environment, and demonstrate concern for social and environmental consequences of proposed actions.
- S3P-0-4e Demonstrate a continuing and more informed interest in science and science-related issues.
- S3P-0-4f Value skepticism, honesty, accuracy, precision, perseverance, and open-mindedness as scientific and technological habits of mind.

## NOTES

---

## ***TOPIC 1: WAVES***

- 1.1: Waves in One Dimension 5
  - 1.2: Waves in Two Dimensions 25
  - 1.3: Sound 41
-

# TOPIC 1: WAVES

---

Waves can be found everywhere in nature, and any understanding of nature requires a knowledge of the characteristics and behaviour of waves. Waves also provide a useful mathematical model for many further investigations in physics, ranging from simple harmonic motion to the nature of light.

By the end of this unit, students will

- develop an understanding of the characteristics and behaviour of mechanical waves, and apply these principles to the most common types of waves in nature
- describe and explain how mechanical waves and sound are produced in nature
- describe and illustrate the principles that govern the production, transmission, interaction, and reception of mechanical waves and sound
- investigate the properties of mechanical waves and sound through experiments
- evaluate the contribution to society, technology, and the environment of technologies that make use of mechanical waves and sound

## Topics

1.1: Waves in One Dimension

1.2: Waves in Two Dimensions

1.3: Sound



## NOTES





---

## **TOPIC 1.1: Waves in One Dimension**

Students will be able to:

- S3P-1-01 Describe a wave as a transfer of energy.  
Include: medium, mechanical wave, pulse, periodic wave
- S3P-1-02 Describe, demonstrate, and diagram the characteristics of transverse and longitudinal waves.  
Include: crest, trough, amplitude, wavelength, compression, rarefaction
- S3P-1-03 Compare and contrast the frequency and period of a periodic wave.  
Include:  $T = \frac{1}{f}$
- S3P-1-04 Derive and solve problems, using the wave equation ( $v = f\lambda$ ).
- S3P-1-05 Describe, demonstrate, and diagram the transmission and reflection of waves travelling in one dimension.  
Include: free and fixed ends, different media
- S3P-1-06 Use the principle of superposition to illustrate graphically the result of combining two waves.  
Include: constructive and destructive interference, nodes, antinodes, standing waves
- S3P-1-07 Investigate the historical development of a significant application of communications technology that uses waves.

*Examples: telephone, radio, television, cell phone, communications satellite, motion detectors, remote controls...*

---

**GENERAL LEARNING OUTCOME CONNECTION**

Students will...

**Understand how stability, motion, forces, and energy transfers and transformations play a role in a wide range of natural and constructed contexts (GLO D4)**

**SPECIFIC LEARNING OUTCOMES**

**S3P-1-01:** Describe a wave as a transfer of energy.

Include: medium, mechanical wave, pulse, periodic wave

**S3P-1-02:** Describe, demonstrate, and diagram the characteristics of transverse and longitudinal waves.

Include: crest, trough, amplitude, wavelength, compression, rarefaction

**S3P-1-03:** Compare and contrast the frequency and period of a periodic wave.

Include:  $T = \frac{1}{f}$

**SUGGESTIONS FOR INSTRUCTION**

**Entry-Level Knowledge**

In Grade 8 optics, students developed an understanding of the behaviour of waves by investigating light rays (ray optics). Students explored the principles of reflection and refraction, and of electromagnetic radiation.

**Notes to the Teacher**

Waves are ubiquitous. Sound waves, microwaves, water waves, and “The Wave” are terms we hear almost every day. There also exist many different phenomena that can be represented by waves. Two very common examples are the swing of a pendulum and the to-and-fro movement of a mass suspended by a spring.

A mechanical wave is a disturbance, a transfer of energy that travels through a medium from one place to another. A wave is not an object in the same sense as a particle: a particle exists at rest, a wave does not. A pulse is a single disturbance, and a periodic wave is a continuing disturbance that is moving through the medium. A sound wave is an example of a mechanical wave.

A medium is the substance or material that carries the disturbance (either a pulse, wave, or periodic wave) from one place to another. For example, sound waves use air as a medium. Sound waves cannot be transmitted through a vacuum.

An electromagnetic wave is a wave that is able to transmit its energy without a medium (i.e., through a vacuum). A radio wave is an example of an electromagnetic wave.

There are two types of waves: transverse and longitudinal. In transverse waves, the particles move perpendicular to the wave motion. In longitudinal waves, the particles move parallel to wave motion.

**Transverse Wave** (e.g., water waves, waves on a string)

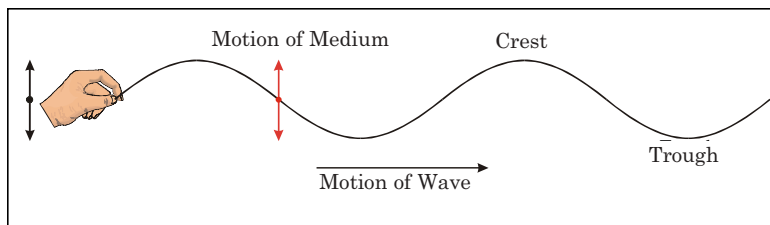

**SKILLS AND ATTITUDES OUTCOMES**

S3P-0-4b: Work cooperatively with a group to identify prior knowledge, initiate and exchange ideas, propose problems and their solutions, and carry out investigations.

S3P-0-2f: Record, organize, and display data, using an appropriate format.

Include: labelled diagrams, tables, graphs

**GENERAL LEARNING OUTCOME CONNECTION**

*Students will...*

**Recognize that energy, whether transmitted or transformed, is the driving force of both movement and change, and is inherent within materials and in the interactions among them (GLO E4)**

**SUGGESTIONS FOR INSTRUCTION**

**SUGGESTIONS FOR ASSESSMENT**

**Longitudinal Wave** (e.g., sound waves or waves in a coil spring toy like a Slinky™)

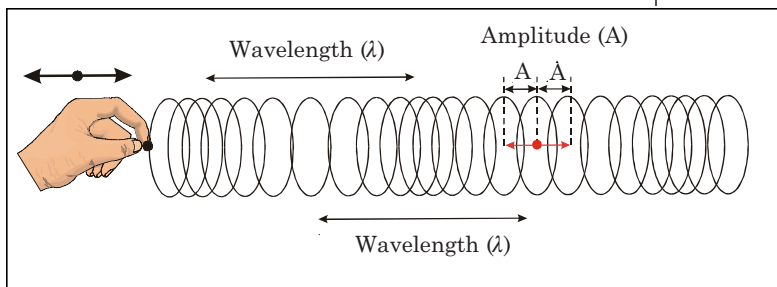

Although transverse and longitudinal waves are physically different, they have the same characteristics of amplitude and wavelength. Therefore, both can be described by the same mathematical model. On a graph, both types of waves are represented by a sinusoidal wave.

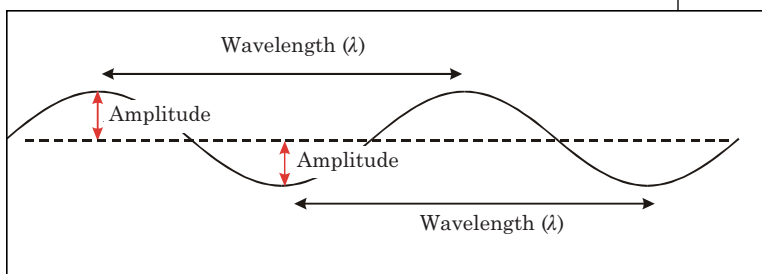

**Science Journal Entries**

Students illustrate with a diagram the difference between a pulse and a travelling wave.

Students provide examples of waves that travel from a source and expend their energy at a different location (i.e., earthquakes, tsunamis).

Students label diagrams of transverse and longitudinal waves.

**Performance Assessment**

Students:

- measure the amplitude and wavelength of actual waves.
- illustrate and/or describe the difference between transverse and longitudinal waves.
- calculate frequency and period for a given motion.



**GENERAL LEARNING OUTCOME CONNECTION**

*Students will...*

**Understand how stability, motion, forces, and energy transfers and transformations play a role in a wide range of natural and constructed contexts (GLO D4)**

**SPECIFIC LEARNING OUTCOMES**

**S3P-1-01:** Describe a wave as a transfer of energy.

Include: medium, mechanical wave, pulse, periodic wave

**S3P-1-02:** Describe, demonstrate, and diagram the characteristics of transverse and longitudinal waves.

Include: crest, trough, amplitude, wavelength, compression, rarefaction

**S3P-1-03:** Compare and contrast the frequency and period of a periodic wave.

Include:  $T = \frac{1}{f}$

**SUGGESTIONS FOR INSTRUCTION**

**Class Activities**

Perform “The Wave” (as at a football game) to imitate a transverse wave. The students represent the particles of the medium and, as they move up and down in a vertical plane, the disturbance moves horizontally through the students. Once the wave has passed a point, the medium is exactly the same as before. To illustrate frequency and period, the students perform “The Wave” for a period of time, such as 30 s, counting the number of times the disturbance passes through them. The frequency (number of waves per unit time) and the period (time for one complete wave) can be calculated. (For an interesting simulation, see [kettering.edu](http://kettering.edu) resource.)

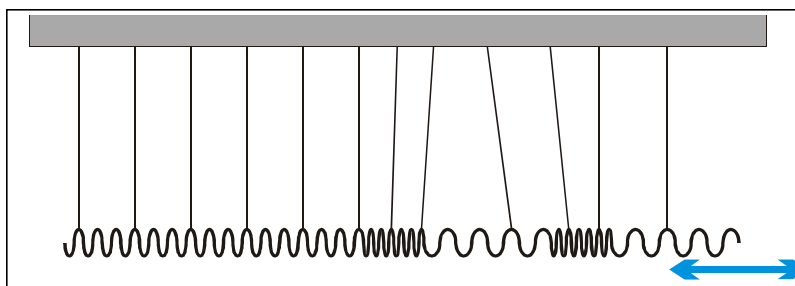

The spring toy can also be used on a smooth tabletop or on the floor. This demonstration uses a bowling pin (or foam cup) to distinguish between the motion of the particles and the motion of the wave.

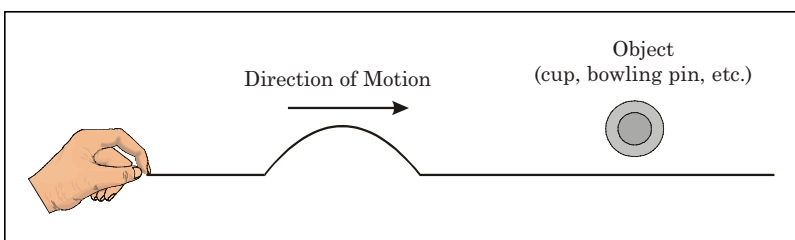

**Teacher Demonstration**

The students’ understanding will be increased if they experience wave phenomena through a series of laboratory exercises. Waves in one dimension can be investigated with strings, springs, and/or a coil spring toy like a Slinky™. A coil spring toy is quite useful in demonstrating wave phenomena. For convenience, the toy can be suspended from the ceiling or a support system (see diagram).

Students may have difficulty with the distinction between the motion of the wave and the motion of the particles of the wave. Wave phenomena often occur so rapidly that they are difficult to observe. Place a piece of masking tape on a coil of the toy spring. This will help students focus on the movement of a single particle. Students can also videotape both types of waves and analyze the wave motion using slow motion, or frame-by-frame advance. A scale can be



**SKILLS AND ATTITUDES OUTCOMES**

S3P-0-4b: Work cooperatively with a group to identify prior knowledge, initiate and exchange ideas, propose problems and their solutions, and carry out investigations.

S3P-0-2f: Record, organize, and display data, using an appropriate format.

Include: labelled diagrams, tables, graphs

**GENERAL LEARNING OUTCOME CONNECTION**

*Students will...*

**Recognize that energy, whether transmitted or transformed, is the driving force of both movement and change, and is inherent within materials and in the interactions among them (GLO E4)**

**SUGGESTIONS FOR INSTRUCTION**

**SUGGESTIONS FOR ASSESSMENT**

used so students can take measurements of amplitude and wavelength. This activity will help students to develop skills in estimating and measuring using Système International (SI) units.

Students also commonly confuse the concepts of period and frequency. There are a number of simple activities that students can do to calculate frequency and period.

**Student Activities**

- Students count their heart rate for a set amount of time. The pulses per minute indicate the frequency of the heartbeat.
- Set a mass on a coiled spring and let the mass oscillate (up and down). Students can count the number of oscillations for 20 seconds and calculate the frequency and period. An Ultrasonic Motion Detector can be used to illustrate how the back-and-forth motion can be represented mathematically as a transverse wave. For both these activities, students collect data, organize them in a table, and analyze them.
- Swing a tennis ball on a string like a pendulum and have students record the time it takes the tennis ball to complete one oscillation (to-and-fro motion). This represents the period of the motion.

**Lab Report**

Students design an experiment where they measure  $\lambda$ ,  $T$ , and  $f$  of transverse waves. Students describe the methodology of their experiment. They collect data and organize the results in a format of their choice. Students also include labelled diagrams, and write the lab report.

**SUGGESTED LEARNING RESOURCES**

**Teacher References**

Spivey, J. (1986) "A Versatile Mount for Slinky Wave Demonstrator." *AAPT Potpourri of Physics Teaching Ideas*: 226.

**Software**

Logal: Waves Exploration 7: Periodic, Traveling Waves

Logal: Waves Exploration 1: Introduction

Exploring Physics and Math with the CBL System (Texas Instruments, 1994), Activity 22

Physics with CBL Experiment 15, Simple Harmonic Motion (Vernier, 1998)



**GENERAL LEARNING OUTCOME CONNECTION**

*Students will...*

**Understand how stability, motion, forces, and energy transfers and transformations play a role in a wide range of natural and constructed contexts (GLO D4)**

**SPECIFIC LEARNING OUTCOMES**

**S3P-1-01:** Describe a wave as a transfer of energy.

Include: medium, mechanical wave, pulse, periodic wave

**S3P-1-02:** Describe, demonstrate, and diagram the characteristics of transverse and longitudinal waves.

Include: crest, trough, amplitude, wavelength, compression, rarefaction

**S3P-1-03:** Compare and contrast the frequency and period of a periodic wave.

Include:  $T = \frac{1}{f}$

**SUGGESTIONS FOR INSTRUCTION**

- Use a strobe to calculate the frequency of periodic motion. (See Appendix 1.1 for an example.)

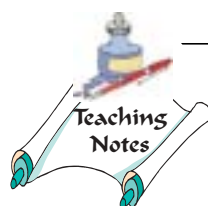

**Senior Years Science Teachers' Handbook Activities**

Working in groups, students use Compare and Contrast Frames (see *Senior Years Science Teachers' Handbook*, page 10.15) for longitudinal and transverse waves.

Students use Compare and Contrast Frames for frequency and period.

Students use a Three-Point Approach to develop concepts such as medium, transverse wave, longitudinal wave, crest, trough, frequency, period, rarefaction, compression, mechanical waves, travelling wave, wave pulse, amplitude (see *Senior Years Science Teachers' Handbook*, page 10.9).

**Journal Writing:** Students imagine themselves sitting on a raft in a wave pool and describe the motion of the raft relative to the motion of the wave. Students can also imagine themselves surfing a wave and describe the amplitude, period, wavelength, speed, and frequency of the wave.



**SKILLS AND ATTITUDES OUTCOMES**

S3P-0-4b: Work cooperatively with a group to identify prior knowledge, initiate and exchange ideas, propose problems and their solutions, and carry out investigations.

S3P-0-2f: Record, organize, and display data, using an appropriate format.

Include: labelled diagrams, tables, graphs

**GENERAL LEARNING OUTCOME CONNECTION**

*Students will...*

**Recognize that energy, whether transmitted or transformed, is the driving force of both movement and change, and is inherent within materials and in the interactions among them (GLO E4)**

**SUGGESTIONS FOR INSTRUCTION**

**SUGGESTIONS FOR ASSESSMENT**

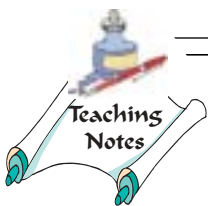

**SUGGESTED LEARNING RESOURCES**

**Applets (websites)**

<<http://www.kettering.edu/~drussell/Demos.html>>

This site focusses on applets and animated demos for waves, including a simulation of “The Wave” with people.

<[http://www.kamikawas.com/physics/java\\_e.htm](http://www.kamikawas.com/physics/java_e.htm)>

<[http://www.kamikawas.com/physics/java\\_e.htm](http://www.kamikawas.com/physics/java_e.htm)>

<<http://www.mta.ca/faculty/science/physics/suren/Applets.html>>

<<http://www.mta.ca/faculty/science/physics/suren/Applets.html>>

**Multimedia**

Cinema Classics videodisc Disk C: Waves (1), Chapter 12, Energy Transfer

Cinema Classics videodisc Disk C: Waves (1), Chapter 11, Wave Vocabulary; Chapter 14, Wave Machine



**GENERAL LEARNING OUTCOME CONNECTION**

*Students will...*

**Demonstrate appropriate scientific inquiry skills when seeking answers to questions (GLO C2)**

**SPECIFIC LEARNING OUTCOME**

**S3P-1-04:** Derive and solve problems, using the wave equation ( $v = f\lambda$ ).

---

**SUGGESTIONS FOR INSTRUCTION**

**Entry-Level Knowledge**

From Senior 2 Science, students are familiar with the definition of speed as

$$v = \frac{\Delta d}{\Delta t}$$

**Notes to the Teacher**

The wave equation can be derived from the definition of speed. The wavelength represents the distance between two successive crests, and the period is the amount of time it takes for one wavelength to pass a given point. Thus,

$$v = \frac{\Delta d}{\Delta t} \quad \Delta d = \lambda \quad \Delta t = T$$

Therefore,

$$v = \frac{\lambda}{T}$$

Students can then formulate the relationship for speed in terms of

frequency, since  $f = \frac{1}{T}$ .

The wave equation is generally written as  $v = f\lambda$ , but either form can be used to solve problems.

***Senior Years Science Teachers' Handbook Activities***

Students write process notes to summarize their strategies for solving problems using the period, the frequency, and the wave equation (see *Senior Years Science Teachers' Handbook*, Writing to Learn Science for Information on Process Notes, page 13.14).

**Student Activities**

(See Appendix 1.1: Strobe Template.)





**SKILLS AND ATTITUDES OUTCOMES**

S3P-0-2c: Formulate operational definitions of major variables or concepts.

S3P-0-2a: Select and use appropriate visual, numeric, graphical, and symbolic modes of representation to identify and represent relationships.

S3P-0-2g: Interpret patterns and trends in data, and infer or calculate linear relationships among variables.

**GENERAL LEARNING OUTCOME CONNECTION**

*Students will...*

**Understand how stability, motion, forces, and energy transfers and transformations play a role in a wide range of natural and constructed contexts (GLO D4)**

**SUGGESTIONS FOR INSTRUCTION**

**SUGGESTIONS FOR ASSESSMENT**

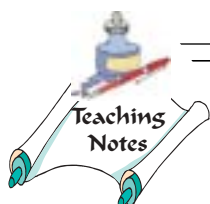

A large empty rectangular box for writing teaching notes, positioned to the left of the assessment suggestions.

**Teacher Observations**

Students use the wave equations to solve problems for speed, wavelength, and frequency.

Students complete a Concept Map (see Appendix 1.2 for an example). Students identify variables for the wave equation and show how they are related.

**Pencil-and-Paper Tasks**

Students compare and contrast the equations:

$$v = \frac{\Delta d}{\Delta t} \text{ and } v = f\lambda$$

**SUGGESTED LEARNING RESOURCES**

**Software**

Logal: Waves Exploration 1: Introduction—wave speed

Appendix 1.2: Concept Map for Wave Equation Variables



**GENERAL LEARNING OUTCOME CONNECTION**

*Students will...*

**Employ effective communication skills and utilize information technology to gather and share scientific and technological ideas and data (GLO C6)**

**SPECIFIC LEARNING OUTCOME**

**S3P-1-05:** Describe, demonstrate, and diagram the transmission and reflection of waves travelling in one dimension.

Include: free and fixed ends, different media

**SUGGESTIONS FOR INSTRUCTION**

**Notes to the Teacher**

Waves incident on a fixed end are reflected on the opposite side.

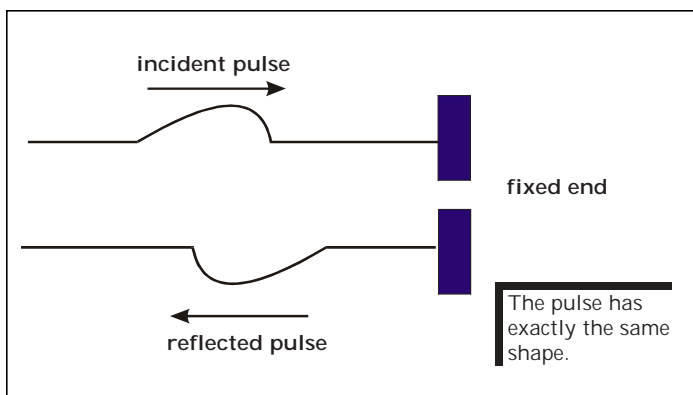

Waves incident on a free end are reflected on the same side.

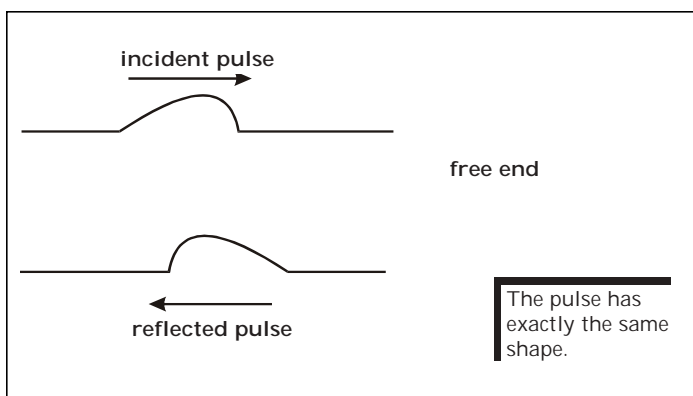

Demonstration of fixed-end reflection is easy. However, demonstration of reflection from a free end is much more difficult because of the damping effect of the wave. Videotape and frame-by-frame advance can be used to reveal same-side reflections.

The frequency of a wave depends on the source alone. The energy of a wave only changes the amplitude of the wave as it moves from one medium to another. Once a wave is produced, the frequency remains the same regardless of the medium. Consequently, as a wave travels from one medium to another, its velocity and wavelength change.

Waves travelling from a light medium to a heavy medium result in partial transmission and partial reflection. The partial reflection is like reflection from a fixed end.

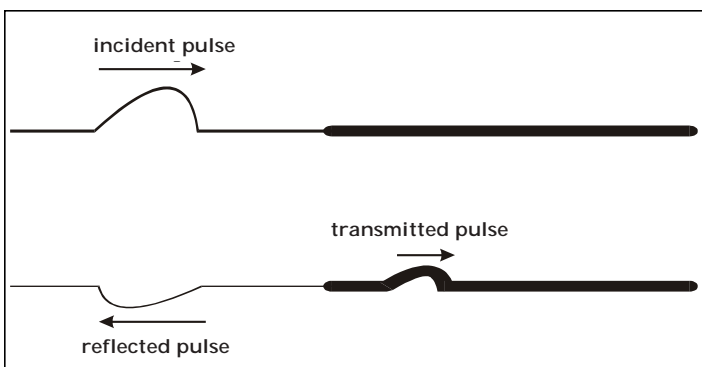

**SKILLS AND ATTITUDES OUTCOME**

S3P-0-2a: Select and use appropriate visual, numeric, graphical, and symbolic modes of representation to identify and represent relationships.

**GENERAL LEARNING OUTCOME CONNECTION**

*Students will...*

**Employ effective communication skills and utilize information technology to gather and share scientific and technological ideas and data (GLO C6)**

**SUGGESTIONS FOR INSTRUCTION**

**SUGGESTIONS FOR ASSESSMENT**

The reflected pulse is on the opposite side of the incident pulse, and the transmitted pulse is on the same side. The reflected pulse has the same wavelength as the incident pulse, since the speed is constant in the same medium. The transmitted pulse has a shorter wavelength than the incident pulse, since speed decreases in a heavier medium. The reflected and transmitted pulses have smaller amplitudes, since some of the energy is transmitted and some is reflected.

Waves travelling from a heavy medium to a light medium result in partial transmission and partial reflection (like from a free end).

**Pencil-and-Paper Tasks**

Students diagram and explain what happens at the junction of two media for a given wave. Examples should include: heavy medium to light medium; light medium to heavy medium.

Students diagram and explain what happens when a wave reflects from a fixed end and from a free end.

Students compare and contrast the effect of light and heavy mediums on transmission and reflection of waves.

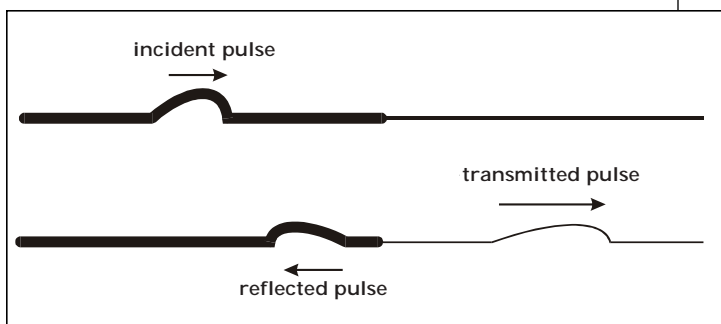

Both of the reflected and the transmitted pulses are on the same side as the incident pulse. The reflected pulse has the same wavelength and a smaller amplitude. The transmitted pulse has a longer wavelength as the wave speeds up in the lighter medium.



**GENERAL LEARNING OUTCOME CONNECTION**

*Students will...*

**Employ effective communication skills and utilize information technology to gather and share scientific and technological ideas and data (GLO C6)**

**SPECIFIC LEARNING OUTCOME**

**S3P-1-05:** Describe, demonstrate, and diagram the transmission and reflection of waves travelling in one dimension.

Include: free and fixed ends, different media

---

**SUGGESTIONS FOR INSTRUCTION**

**Student Activity**

Students perform a lab, use computer simulations, and/or use a video camera to film the motion of waves. For a light medium, they could use a common coil spring toy; for a heavy medium, they can use a heavier, tightly coiled spring (sets are available from science suppliers).

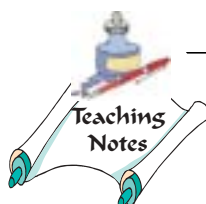

---



**SKILLS AND ATTITUDES OUTCOME**

S3P-0-2a: Select and use appropriate visual, numeric, graphical, and symbolic modes of representation to identify and represent relationships.

**GENERAL LEARNING OUTCOME CONNECTION**

*Students will...*

**Employ effective communication skills and utilize information technology to gather and share scientific and technological ideas and data (GLO C6)**

**SUGGESTIONS FOR INSTRUCTION**



A large empty rectangular box for writing suggestions for instruction.

**SUGGESTIONS FOR ASSESSMENT**

**Lab Report**

Students observe the speed of the wave, the wavelength, the amplitude, and how the wave is reflected at the junction or endpoint. Students describe their observations in the lab report. (See *Senior Years Teachers' Handbook*, Laboratory Report Format, page 14.3.)

**SUGGESTED LEARNING RESOURCES**

**Multimedia**

Physics: Cinema Classics videodisc Disk C: Waves (1), Chapter 52, Wave Machine

**Software**

Logal: Waves Exploration 3: Behaviour at the End of a String

**Applets (Websites)**

<[http://www.kamikawas.com/physics/java\\_e.htm](http://www.kamikawas.com/physics/java_e.htm)>

<[http://www.kamikawas.com/physics/java\\_e.htm](http://www.kamikawas.com/physics/java_e.htm)>

Wave Machine (can show the reflection of waves from a free or fixed end; must be done step by step)

<<http://www.kettering.edu/~drussell/Demos/reflect/reflect.html>>



**GENERAL LEARNING OUTCOME CONNECTION**

*Students will...*

**Employ effective communication skills and utilize information technology to gather and share scientific and technological ideas and data (GLO C6)**

**SPECIFIC LEARNING OUTCOME**

**S3P-1-06:** Use the principle of superposition to illustrate graphically the result of combining two waves.

Include: constructive and destructive interference, nodes, antinodes, standing waves

---

**SUGGESTIONS FOR INSTRUCTION**

**Notes to the Teacher**

When waves travel in the same region of space, they may interfere with each other. The resultant displacement is the sum of the individual displacements of the interfering waves. Waves can interfere constructively (the result is a larger amplitude) or destructively (the result is a smaller amplitude). Total destructive interference can occur when the interfering waves have identical wavelengths and amplitudes. The result is a region of no disturbance called a node.

If two opposing waves have the same amplitude and wavelength, they interfere with each other such that there are points in the medium that appear to be standing still. These points are called nodes and the interference pattern is called a standing wave. A standing wave can easily be produced by fixing one end of a coil spring toy, and vibrating the other end at just the right frequency. The pattern is regular and repeatable with a series of nodal points clearly visible. Try attaching a piece of tape to a nodal point to illustrate that it is not moving.

Waves generated on the same side of the spring will produce constructive interference as they overlap. Waves generated on opposite sides of the spring will produce destructive interference as they overlap. The points on the spring between the nodes move back and forth rapidly. These points are where constructive interference occurs and are called antinodes. The distance between successive nodes or antinodes in a standing wave interference pattern is one-half the wavelength of the interfering waves.

**Student Activities**

Students perform a lab, computer simulation, videodisc observation, and/or "paper lab" task. Students can also measure the displacement of each of the wave pulses and add them to determine the total displacement.

In a "paper lab" task, students can analyze waves with ideal shapes, such as rectangles and triangles, to practise using the principle of superposition. Students will develop the skill of measurement as they add up individual displacements of the waves. (See Appendix 1.3: Superposition of Waves.)



**SKILLS AND ATTITUDES OUTCOMES**

S3P-0-2d: Estimate and measure accurately, using Système International (SI) units.

S3P-0-2f: Record, organize, and display data, using an appropriate format.

Include: labelled diagrams, tables, graphs

**GENERAL LEARNING OUTCOME CONNECTION**

*Students will...*

**Employ effective communication skills and utilize information technology to gather and share scientific and technological ideas and data (GLO C6)**

**SUGGESTIONS FOR INSTRUCTION**

Students can videotape waves travelling in a spring. Pulses can be generated at opposite ends of a spring. Using stop action, students can observe the waves before they overlap, during the period of overlapping while interference is occurring, and after the waves have passed through each other.

**Demonstration**

The diagram below illustrates constructive interference. Students A and B hold opposite ends of a coil spring toy or similar spring. At the same time, they generate pulses large enough to just clear the bricks. When the waves meet, they constructively interfere and produce a larger wave that knocks over the pop can. The waves then continue to travel past the bricks without touching. With a little practice, this can be accomplished with regularity. Videotape and play back the tape in slow motion.

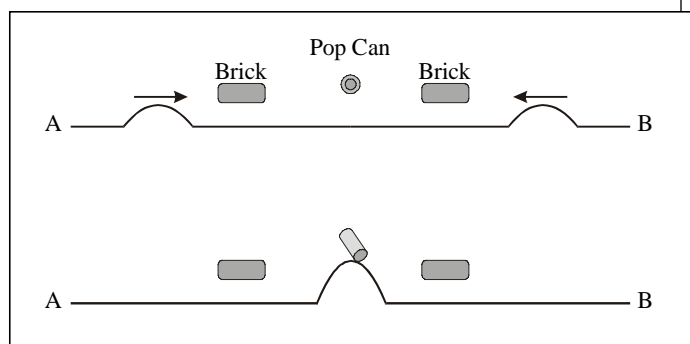
**SUGGESTIONS FOR ASSESSMENT**
**Teacher Observation**

Students measure the displacements of the overlapped waves.

Students diagram two waves overlapping to illustrate the Principle of Superposition.

Students draw wave pulses that are travelling towards each other in the same medium before they overlap, in the region of interference, and after they have passed through each other. (See Appendix 1.3: Superposition of Waves, and Appendix 1.4: Waves in One Dimension.)

**SUGGESTED LEARNING RESOURCES**
**Multimedia**

Physics: Cinema Classics videodisc Disk C: Waves (1), Chapter 31, Computer Animation; Chapter 32, Slinky; Chapter 42, Wave Machine

**Software**

Logal: Waves Core 3 Superposition

Exploration 6: Superposition: When Two Waves Meet

Exploration 8: Standing Waves, Core 4 Standing Waves



**GENERAL LEARNING OUTCOME CONNECTION**

*Students will...*

**Employ effective communication skills and utilize information technology to gather and share scientific and technological ideas and data (GLO C6)**

**SPECIFIC LEARNING OUTCOME**

**S3P-1-06:** Use the principle of superposition to illustrate graphically the result of combining two waves.

Include: constructive and destructive interference, nodes, antinodes, standing waves

**SUGGESTIONS FOR INSTRUCTION**

Standing waves can also be produced with a skipping rope. Attach one end of the rope to a doorknob. Hold the other end of the rope in your hand. Move your hand up and down to generate a wave of fixed frequency. Points on the rope will become stationary.

**Teacher/Student Demonstration**

An old jigsaw (with blades removed!) or other similar device can be used to move a string rapidly up and down to produce standing waves. Use a 1-kg mass to produce up to three nodes. Caution: noisy demo!

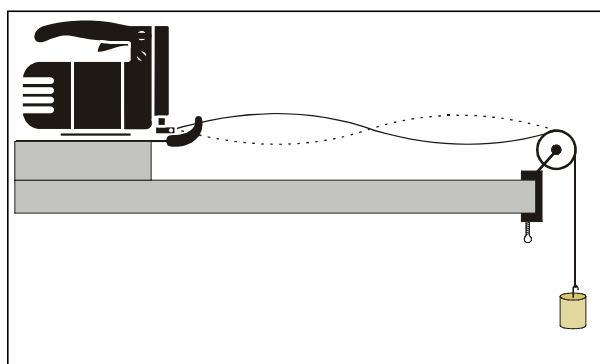

**Teacher/Student Demonstration**

Sprinkle some fine dust on a fixed metal plate and stroke the plate with a violin bow. The dust will move away from certain areas and toward others. The particles move away from the interference nodes. The dust formation is called a Chladni pattern.

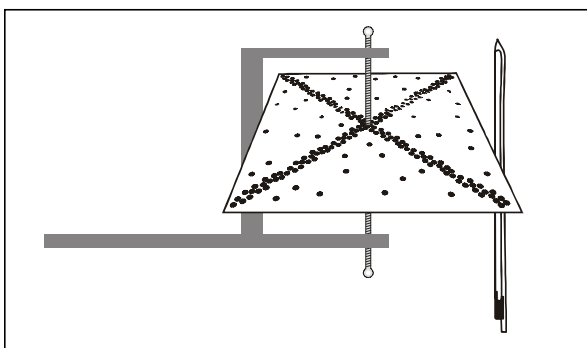

**Senior Years Science Teachers' Handbook Activities**

Students use a Concept Map to show the relationships between constructive and destructive interference, nodes, antinodes, and standing waves.





**SKILLS AND ATTITUDES OUTCOMES**

S3P-0-2d: Estimate and measure accurately, using Système International (SI) units.

S3P-0-2f: Record, organize, and display data, using an appropriate format.

Include: labelled diagrams, tables, graphs

**GENERAL LEARNING OUTCOME CONNECTION**

*Students will...*

**Employ effective communication skills and utilize information technology to gather and share scientific and technological ideas and data (GLO C6)**

**SUGGESTIONS FOR INSTRUCTION**

**SUGGESTIONS FOR ASSESSMENT**

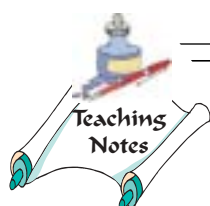

Teaching Notes

**SUGGESTED LEARNING RESOURCES**

**Applets (Websites)**

<[http://users.erols.com/renau/applet\\_menu.html](http://users.erols.com/renau/applet_menu.html)>

<<http://www.phys.hawaii.edu/~teb/java/ntnujava/>>

<<http://www.mta.ca/faculty/science/physics/suren/Applets.html>>

<<http://www.physicsweb.com>>

This site contains an extensive bank of questions dealing with waves.

<[http://explorescience.com/activities/activity\\_page.cfm?ActivityID=44](http://explorescience.com/activities/activity_page.cfm?ActivityID=44)>

Hear beats produced for fixed frequencies. Change frequencies and hear the number of beats change.

<<http://www.cs.earlham.edu/~rileyle/Applet.html>>

Adjust the frequency and see the program plot graphically the beats produced.

<<http://susy.phys.nwu.edu/%7Eanderson/java/vpl/waves/superposition2.html>>

<<http://mta.ca/faculty/science/physics.suren/Applets.html>>



**GENERAL LEARNING OUTCOME CONNECTION**

*Students will...*

**Describe scientific and technological developments, past and present, and appreciate their impact on individuals, societies, and the environment, both locally and globally (GLO B1)**

**SPECIFIC LEARNING OUTCOME**

**S3P-1-07:** Investigate the historical development of a significant application of communications technology that uses waves.

*Examples: telephone, radio, television, cell phone, communications satellite, motion detectors, remote controls...*

**SKILLS AND ATTITUDES OUTCOMES**

S3P-0-1c: Relate the historical development of scientific ideas and technology to the form and function of scientific knowledge today.

---

**SUGGESTIONS FOR INSTRUCTION**

**Notes to the Teacher**

Students should understand that waves have very practical applications in modern technological devices. This learning outcome provides a brief introduction to some of the devices that utilize wave technology.

**Collaborative Teamwork**

Students research and report on one significant product of communications technology.

Students can construct a timeline of the chronological development of significant products of communication technology with a focus on the development of scientific ideas and technology.

***Senior Years Science Teachers' Handbook Activities***

Students use a jigsaw activity (*Senior Years Science Teachers' Handbook*, page 3.20) so that each student becomes an "expert" on one specific device by meeting and sharing research with other "experts." Each "expert" reports back to her or his original group.



**SKILLS AND ATTITUDES OUTCOMES**

S3P-0-2i: Select and integrate information obtained from a variety of sources.

Include: print, electronic, and/or specialist sources, resource people

S3P-0-3b: Describe examples of how technology has evolved in response to scientific advances, and how scientific knowledge has evolved as the result of new innovations in technology.

**GENERAL LEARNING OUTCOME CONNECTION**

*Students will...*

**Demonstrate a knowledge of, and personal consideration for, a range of possible science- and technology-related interests, hobbies, and careers (GLO B4)**

**SUGGESTIONS FOR INSTRUCTION**

**SUGGESTIONS FOR ASSESSMENT**

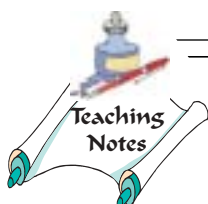

**Research Report/Presentation**

Student/group presentation is made to the class on a significant product of communication technology.

**Visual Displays**

Students do a gallery walk of historical timeline posters.

Museum Quest: Students research artifacts online in museums of science and technology. Students can then prepare a report, poster presentation, or multimedia presentation.

**SUGGESTED LEARNING RESOURCES**

**Museums**

<<http://shot.press.jhu.edu/links.htm>>



## NOTES



---

## ***TOPIC 1.2: Waves in Two Dimensions***

Students will be able to:

- S3P-1-08 Describe and give examples of two-dimensional waves.
- S3P-1-09 Compare and contrast a wavefront and a wave ray.
- S3P-1-10 Describe, demonstrate, and diagram the reflection of plane (straight) and circular waves.  
Include: linear and parabolic reflectors
- S3P-1-11 Describe, demonstrate, and diagram the refraction of plane (straight) waves.
- S3P-1-12 Derive Snell's Law using the relationships between wavelength, velocity, and the angles of incidence and refraction.
- S3P-1-13 Experiment to demonstrate Snell's Law.
- S3P-1-14 Describe, demonstrate, and diagram diffraction of water waves.
- S3P-1-15 Describe, demonstrate, and diagram how constructive and destructive interference produce an interference pattern from two point sources.
- S3P-1-16 Derive the path difference relationship for the interference pattern from two point sources  $|\overline{P_n S_1} - \overline{P_n S_2}| = \left(n - \frac{1}{2}\right)\lambda$ .
-

**GENERAL LEARNING OUTCOME CONNECTION**

*Students will...*

**Employ effective communication skills and utilize information technology to gather and share scientific and technological ideas and data (GLO C6)**

**SPECIFIC LEARNING OUTCOMES**

**S3P-1-08:** Describe and give examples of two-dimensional waves.

**S3P-1-09:** Compare and contrast a wavefront and a wave ray.

**SKILLS AND ATTITUDES OUTCOMES**

S3P-0-2f: Record, organize, and display data, using an appropriate format.

Include: labelled diagrams, tables, graphs

**SUGGESTIONS FOR INSTRUCTION**

**Notes to the Teacher**

In the previous topic, waves on a string or spring were used to outline the properties of waves in one dimension. A useful example of waves in two dimensions is water waves. It is recommended that students observe waves in two dimensions and highlight the characteristics of their behaviour. Students can use ripple tanks or the teacher can demonstrate water waves using a ripple tank placed on an overhead.

Distinguish between wavefronts and wave rays. A wavefront is a series of connected particles moving in phase with one another. The wave ray represents the direction of motion of a point on the wavefront. The direction of motion of the wave ray is perpendicular to the wavefront at that point.

**Class Activity**

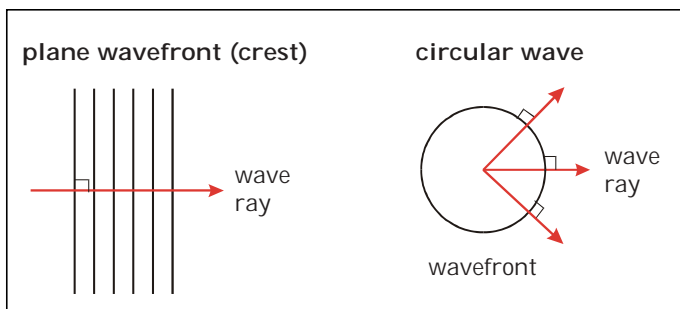

Waves in ripple tanks can be used to illustrate two-dimensional waves. It is useful to videotape wave phenomena and play back the tape in slow motion or frame by frame. In a ripple tank apparatus, the wave crest acts like a converging lens and the crest is projected on a screen below as a bright area. A ruler and stopwatch could be placed in view while videotaping.

You can generate a straight wave in a ripple tank by dipping a wooden dowel into the water. Students can generate circular waves in a ripple tank by dipping a single finger into the water, or by using an eyedropper to drop water droplets into the ripple tank.

**Demonstration**

Strike a tuning fork and place it near an open beaker of water to generate waves in the beaker.

**Senior Years Science Teachers' Handbook Activities**

KWL (*Senior Years Science Teachers' Handbook*, page 9.8): Students research the impact of waves on the shorelines of lakes, oceans, and harbours, and the impact of wakes from boats on spawning fish or wildlife (e.g., the nesting areas of loons). Various research benefits, problems, and costs can be addressed.



**SKILLS AND ATTITUDES OUTCOMES**

S3P-0-2i: Select and integrate information obtained from a variety of sources.

Include: print, electronic, and/or specialist sources, resource people

S3P-0-3c: Identify social issues related to science and technology, taking into account human and environmental needs and ethical considerations.

**GENERAL LEARNING OUTCOME CONNECTION**

*Students will...*

**Employ effective communication skills and utilize information technology to gather and share scientific and technological ideas and data (GLO C6)**

**SUGGESTIONS FOR INSTRUCTION**

**SUGGESTIONS FOR ASSESSMENT**

Students use an Anticipation Guide (*Senior Years Science Teachers' Handbook*, page 9.20) for an article that researches the problems, benefits, and costs that accompany society's use of one of the following: microwaves, radio waves, X-rays.

Students use Article Analysis Frames and Research Notes frames to organize information from various sources. (See *Senior Years Science Teachers' Handbook*, Developing Concepts Using Graphic Displays, and Writing to Learn Science, page 11.30.)

Students use Compare and Contrast Frames for wavefront and wave ray.

**Teacher Observations**

Students draw and label a diagram of a straight wave and a circular wave.

Students identify wavefronts and wave rays, and relate these to events in the ripple tank.

Students describe and give examples of two-dimensional waves.

**Research Report (Oral or Written)**

Students report on common natural waves.



**GENERAL LEARNING OUTCOME CONNECTION**

*Students will...*

**Employ effective communication skills and utilize information technology to gather and share scientific and technological ideas and data (GLO C6)**

**SPECIFIC LEARNING OUTCOME**

**S3P-1-10:** Describe, demonstrate, and diagram the reflection of plane (straight) and circular waves.

Include: linear and parabolic reflectors

**SUGGESTIONS FOR INSTRUCTION**

**Notes to the Teacher**

Outcomes S3P-1-08–S3P-1-10 are closely connected to outcomes S3P-2-06–S3P-2-09 in the Nature of Light topic (wave model of light). It is recommended to first examine the characteristics of waves in general and then later (in Topic 2) extend these ideas to light. However, some teachers may prefer to introduce the wave nature of light at this time. At this point, the teacher can decide whether to limit the description of these wave characteristics in terms of water waves or extend these characteristics to light waves.

Students should be able to draw diagrams of the observed phenomena, identify the focal points (for parabolic reflectors), and label the normal angle of incidence and angle of reflection for each case.

**Student Activity**

Students perform a lab with pulses in a ripple tank; use computer simulations; videotape and replay waves in a ripple tank in slow motion or frame by frame.

All the above activities will support the implementation and adaptation of the Law of Reflection under various conditions.

**Senior Years Science Teachers' Handbook Activities**

Students use the Three-Point Approach to build the concepts of reflection of waves in various conditions.

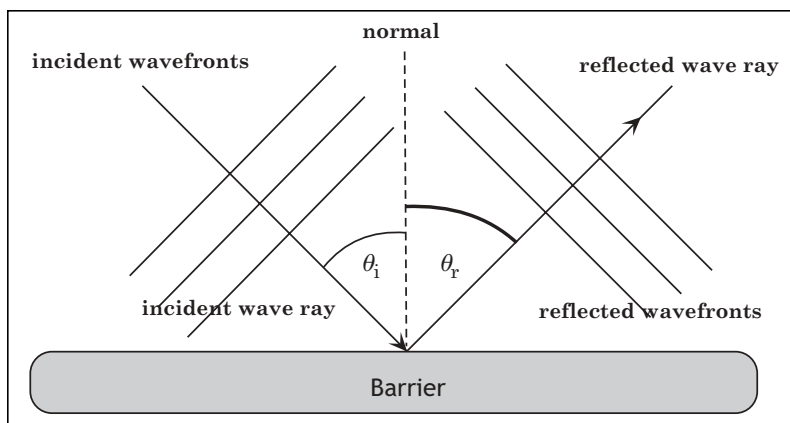

Reflection of Plane Wave





**SKILLS AND ATTITUDES OUTCOME**

S3P-0-2b: Propose problems, state hypotheses, and plan, implement, adapt, or extend procedures to carry out an investigation where required.

**GENERAL LEARNING OUTCOME CONNECTION**

*Students will...*

**Employ effective communication skills and utilize information technology to gather and share scientific and technological ideas and data (GLO C6)**

**SUGGESTIONS FOR INSTRUCTION**

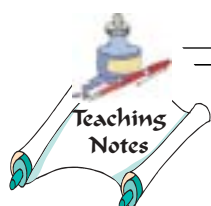

Empty box for teaching notes.

**SUGGESTIONS FOR ASSESSMENT**

**Performance Assessment/Student Demonstration**

Students diagram and label reflection of straight waves from linear reflectors.

Students diagram and label reflection of circular waves from linear and concave reflectors.

**Visual Displays**

Students work in a team to do a lab with pulses in a ripple tank, and prepare a visual display of their observations.

**SUGGESTED LEARNING RESOURCES**

**Multimedia**

Physics: Cinema Classics videodisc Disk C: Waves (1), Chapter 53, Water: Plane Surfaces; Chapter 54, Water: Curved Surfaces

*Video Encyclopedia of Physics Demonstrations* (1992) videodisc

**Software**

Logal: Ripple Tank Core 1: It's All Done by Mirrors



**GENERAL LEARNING OUTCOME CONNECTION**

*Students will...*

**Employ effective communication skills and utilize information technology to gather and share scientific and technological ideas and data (GLO C6)**

**SPECIFIC LEARNING OUTCOME**

**S3P-1-11:** Describe, demonstrate, and diagram the refraction of plane (straight) waves.

**SUGGESTIONS FOR INSTRUCTION**

**Notes to the Teacher**

Outcomes S3P-1-08–S3P-1-11 are closely connected to outcomes SP3-2-06–SP3-2-09 in the Nature of Light topic (wave model of light). At this point, the teacher can decide whether to describe these wave characteristics in terms of water waves, or to extend these characteristics to light waves.

Use a ripple tank placed on an overhead to show refraction of straight waves as the waves go from shallow water to deep water and from deep water to shallow water. To create a refractive medium, use a flat piece of glass to change the depth of the water. Diagram the path of the incident wave hitting a different medium, passing through this medium, to exit back into the initial medium. This activity lends itself to understanding the theoretical basis of refraction and that the change in direction of motion of the wavefront is the result of the change in velocity of the wave.

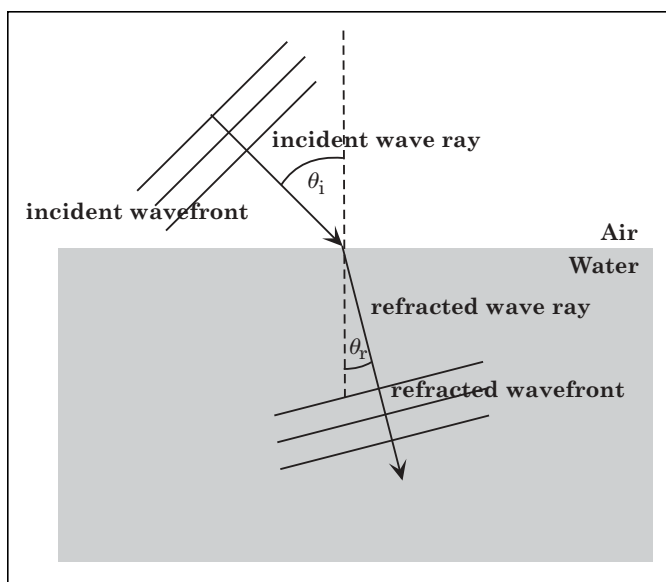

According to the wave model, the wavefront slows down as it enters from a less optically dense medium to a more optically dense medium. This causes the refracted wavefront to travel in a different direction.

**Senior Years Science Teachers' Handbook Activities**

Students complete Compare and Contrast Frames for reflection and refraction.



**SKILLS AND ATTITUDES OUTCOME**

S3P-0-2b: Propose problems, state hypotheses, and plan, implement, adapt, or extend procedures to carry out an investigation where required.

**GENERAL LEARNING OUTCOME CONNECTION**

*Students will...*

**Understand how stability, motion, forces, and energy transfers and transformations play a role in a wide range of natural and constructed contexts (GLO D4)**

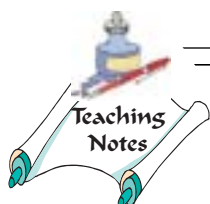
**SUGGESTIONS FOR INSTRUCTION****SUGGESTIONS FOR ASSESSMENT****Pencil-and-Paper Tasks**

Students draw and label diagrams of wavefronts passing through the surface of two media. Diagrams should include the angle of incidence, the normal, the angle of refraction, and the wave ray.

Students draw and label diagrams of wave rays passing through the surface of two media. Diagrams should include the angle of incidence, the normal, the angle of refraction, and the wavefront.

**SUGGESTED LEARNING RESOURCES****Multimedia**

Cinema Classics videodisc Disk C: Waves (1), Chapter 61; Chapter 62

**Software**

Logal: Ripple Tank Exploration 2: Two Media

**Applets (Websites)**

<<http://www.physics.nwu.edu/ugrad/vpl/index.html>>

<<http://www.phys.hawaii.edu/~teb/java/ntnujava/>>

<<http://www.physics.nwu.edu/ugrad/vpl/index.html>>



**GENERAL LEARNING OUTCOME CONNECTION**

*Students will...*

**Recognize both the power and limitations of science as a way of answering questions about the world and explaining natural phenomena (GLO A1)**

**SPECIFIC LEARNING OUTCOME**

**S3P-1-12:** Derive Snell's Law using the relationships between wavelength, velocity, and the angles of incidence and refraction.

---

**SUGGESTIONS FOR INSTRUCTION**

**Notes to the Teacher**

Outcomes S3P-1-12–S3P-1-13 are closely connected to outcomes S3P-2-06–S3P-2-09 in the Nature of Light topic (wave model of light). At this point, the teacher can decide whether to describe these wave characteristics in terms of water waves, or to extend these characteristics to light waves.

Demonstrate or have students complete lab activities related to waves in ripple tanks. Videotapes of wave phenomena are useful when played back in slow/stop action sequence. Derive Snell's Law from the geometry of the wavefronts (see Appendix 1.5: Derivation of Snell's Law).

Students will relate the visual representation of refraction to the symbolic mode.

***Senior Years Science Teachers' Handbook Activities***

Students use Compare and Contrast Frames for reflection and refraction.

Students apply a Category Concept Map for Snell's Law of Refraction.

Students write process notes for solving Snell's Law problems.



**SKILLS AND ATTITUDES OUTCOMES**

S3P-0-2a: Select and use appropriate visual, numeric, graphical, and symbolic modes of representation to identify and represent relationships.

S3P-0-2g: Interpret patterns and trends in data, and infer or calculate linear relationships among variables.

**GENERAL LEARNING OUTCOME CONNECTION**

*Students will...*

**Recognize that scientific knowledge is based on evidence, models, and explanations, and evolves as new evidence appears and new conceptualizations develop (GLO A2)**

**SUGGESTIONS FOR INSTRUCTION**

**SUGGESTIONS FOR ASSESSMENT**

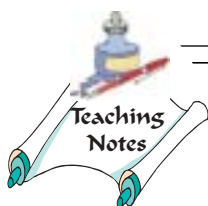

A large empty rectangular box for providing suggestions for instruction.

**Pencil-and-Paper Tasks**

Students solve problems using Snell's Law.

Students diagram refraction using wavefronts.

Given a diagram of the wavefronts travelling from one medium to another, students label the angles of incidence and refraction, and derive Snell's Law. (See "Working with Snell's Law and Wavefronts" in Appendix 1.5: Derivation of Snell's Law.)

**SUGGESTED LEARNING RESOURCES**

**Multimedia**

Physics: Cinema Classics videodisc Disk C: Waves, Chapter 62, Water (refraction example)



**GENERAL LEARNING OUTCOME CONNECTION**

*Students will...*

**Demonstrate appropriate scientific inquiry skills when seeking answers to questions (GLO C2)**

**SPECIFIC LEARNING OUTCOME**

**S3P-1-13:** Experiment to demonstrate Snell's Law.

**SKILLS AND ATTITUDES OUTCOMES**

S3P-0-2b: Propose problems, state hypotheses, and plan, implement, adapt, or extend procedures to carry out an investigation where required.

**SUGGESTIONS FOR INSTRUCTION**

**Notes to the Teacher**

Outcomes S3P-1-11–S3P-1-16 are closely connected to outcomes S3P-2-06–S3P-2-12 in the Nature of Light topic (wave model of light). Teachers can decide whether to describe these wave characteristics strictly in terms of water waves, or to extend these characteristics to light waves. In particular, the experiment on refraction and Snell's Law could be done:

- at this point with water waves
- at this point with light
- or, it could be completed later with light

For Nature of Light outcome S3P-0-1, the phenomenon we call refraction can be explained by the statement: "as waves travel from deep water to shallow water, the direction of motion of the wavefront changes because the speed of the wavefront changes." The degree of this change in the direction of motion depends on the degree to which the speed of the wavefront changes. Scientific laws, in particular Snell's Law, identify this regularity and summarize it concisely.

**Class Activity**

Snell's Law can be investigated using periodic waves in a ripple tank that travel from one depth of water to another. Use a flat, glass plate to change the depth of water. Students trace the wave pattern on a screen below the ripple tank (or on any other screen) and then measure the angles of incidence and refraction.

There are several labs to investigate Snell's Law using light rays. The typical lab uses a glass block or cheese box filled with liquid as the refracting medium (see diagram below). The student observes pins and traces the path of the incident and refracted rays on paper. Then, the student records several angles of incidence and angles of refraction and displays these in a data table. Students then analyze and interpret the data to determine the linear relation between  $\sin\theta_i$  and  $\sin\theta_r$ .

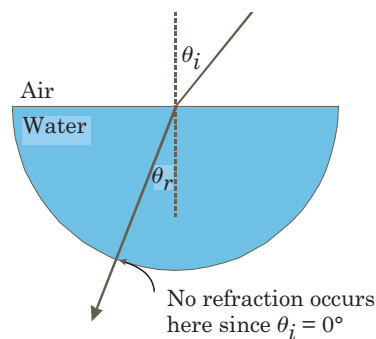

**SKILLS AND ATTITUDES OUTCOMES**

S3P-0-2f: Record, organize, and display data, using an appropriate format.

Include: labelled diagrams, tables, graphs

S3P-0-1e: Differentiate between how scientific theories explain natural phenomena and how scientific laws identify regularities and patterns in nature.

**GENERAL LEARNING OUTCOME CONNECTION**

*Students will...*

**Demonstrate appropriate scientific inquiry skills when seeking answers to questions (GLO C2)**

**SUGGESTIONS FOR INSTRUCTION**

**SUGGESTIONS FOR ASSESSMENT**

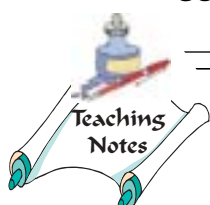

A large empty rectangular box for writing suggestions for instruction.

**Pencil-and-Paper Tasks**

Students solve problems using Snell's Law.

**Asking and Answering Questions Based on Data**

Students make predictions using Snell's Law (e.g., speed of the waves in water).

Students prepare a lab report on Snell's Law. (See *Senior Years Science Teachers' Handbook*, page 14.12.)



**GENERAL LEARNING OUTCOME CONNECTION**

*Students will...*

**Employ effective communication skills and utilize information technology to gather and share scientific and technological ideas and data (GLO C6)**

**SPECIFIC LEARNING OUTCOME**

**S3P-1-14:** Describe, demonstrate, and diagram diffraction of water waves.

**SUGGESTIONS FOR INSTRUCTION**

**Notes to the Teacher**

Outcomes S3P-1-14–S3P-1-16 are closely connected to outcomes S3P-2-06–S3P-2-09 in the Nature of Light topic (wave model of light). At this point, the teacher can decide whether to describe these wave characteristics in terms of water waves, or to extend these characteristics to light waves. In particular, diffraction can be dealt with:

- water waves at this point
- light at this point
- light at a later time

**Teacher Demonstration**

The teacher speaks to the class from outside the room with the door open, and students notice that the voice can be heard inside the classroom.

This simple demonstration points out the ability of sound waves to “diffract” around corners. We can expect that very little audible sound would pass directly through the walls.

**Student Activity**

Using ripple tanks, students can generate diffraction, or they can view diffraction on video/DVD. Use different-size wavelengths and vary the slit opening to demonstrate the different diffraction patterns.

Students visually note the phenomenon of diffraction.

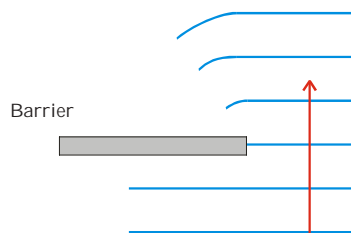

Diffraction as plane waves pass the edge of a straight barrier.

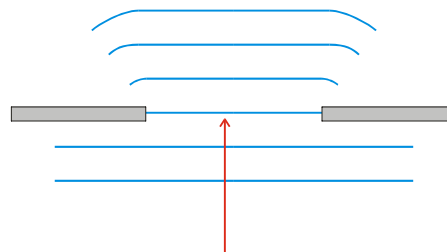

Diffraction as plane waves pass through an opening in a barrier.





**SKILLS AND ATTITUDES OUTCOME**

S3P-0-2a: Select and use appropriate visual, numeric, graphical, and symbolic modes of representation to identify and represent relationships.

**GENERAL LEARNING OUTCOME CONNECTION**

*Students will...*

**Employ effective communication skills and utilize information technology to gather and share scientific and technological ideas and data (GLO C6)**

**SUGGESTIONS FOR INSTRUCTION**

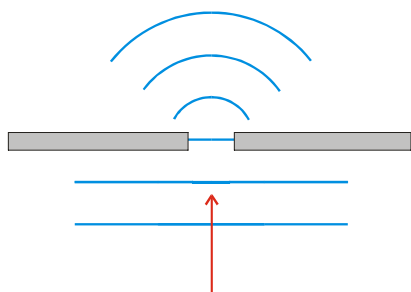

When the slit width and the wavelength are approximately equal in value, then the diffraction pattern will be the most pronounced.

**SUGGESTIONS FOR ASSESSMENT**

**Pencil-and-Paper Tasks**

Students diagram different diffraction patterns.

Students diagram diffraction patterns for various slit widths and various wavelengths.

**SUGGESTED LEARNING RESOURCES**

**Multimedia**

Cinema Classics videodisc Disk D: Waves (11), Chapter 11, Water Waves—Ripple Tank; Chapter 21, Water Waves—Ripple Tank



**GENERAL LEARNING OUTCOME CONNECTION**

*Students will...*

**Recognize that scientific knowledge is based on evidence, models, and explanations, and evolves as new evidence appears and new conceptualizations develop (GLO A2)**

**SPECIFIC LEARNING OUTCOMES**

**S3P-1-15:** Describe, demonstrate, and diagram how constructive and destructive interference produce an interference pattern from two point sources.

**S3P-1-16:** Derive the path difference relationship for the interference pattern from two point sources

$$\left| \overline{P_n S_1} - \overline{P_n S_2} \right| = \left( n - \frac{1}{2} \right) \lambda.$$

**SUGGESTIONS FOR INSTRUCTION**

**Notes to the Teacher**

The two-point interference pattern is used in Topic 2, The Nature of Light, to derive Young's relationship to find the wavelength of light. Most textbooks will derive this relationship at that time. Since the derivation is lengthy and quite challenging for students, it is suggested that it be completed in two steps. The first step involves identifying the geometrical relationships of a wave pattern in general. The path difference can be calculated through simple constructions and by counting wavelengths. Later, this relationship for path difference provides the basis for Young's derivation.

Use circular waves generated in a ripple tank to observe the two-point interference pattern. Alternately, a videodisc or computer simulation can be used to view the interference pattern.

Copy the waves from a single point source pattern to a transparency. If two transparencies of this circular wave pattern are overlapped, patterns for different source separations can be quickly demonstrated. These patterns on the transparencies can be quickly copied to produce test items or questions (see Appendix 1.6: Circular Wave Patterns).

**Teacher Demonstration**

Moiré acetates are used to show interference patterns on the overhead (see Appendix 1.8 for various patterns).

**Student Activity**

Given an interference pattern from two point sources, students will map the nodal patterns. A nodal point is found at the intersection of a crest and a trough. In the diagram, the crests are represented by a solid line and the troughs are represented by a dotted line. Therefore, label a node at the point where a solid and dotted line intersect. Students can number the nodal point from the perpendicular bisector as  $P_1$ ,  $P_2$ , et cetera. By counting the number of wavelengths from each source, the path length difference,  $P_1 S_1 - P_1 S_2$ , can be determined.

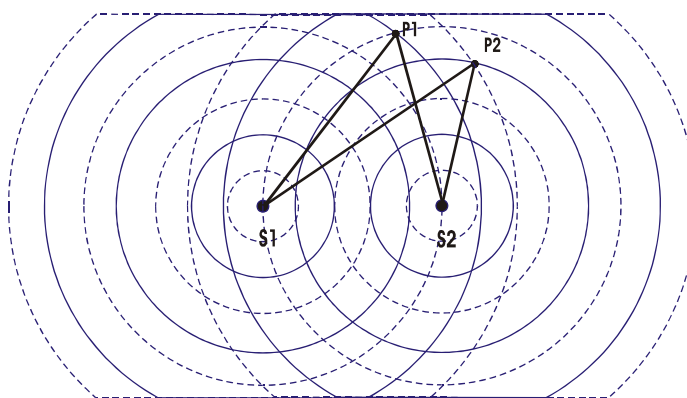

**SKILLS AND ATTITUDES OUTCOMES**

S3P-0-2g: Interpret patterns and trends in data, and infer or calculate linear relationships among variables.

S3P-0-2f: Record, organize, and display data, using an appropriate format.

Include: labelled diagrams, tables, graphs

**GENERAL LEARNING OUTCOME CONNECTION**

*Students will...*

**Recognize that scientific knowledge is based on evidence, models, and explanations, and evolves as new evidence appears and new conceptualizations develop (GLO A2)**

**SUGGESTIONS FOR INSTRUCTION**

For example, the number of crests from  $S_1$  to  $P_1$  is 3 (count the solid lines from  $S_1$  to  $P_1$ ). The number of crests from  $S_2$  to  $P_1$  is  $2\frac{1}{2}$ . Therefore,

$$P_1S_1 - P_1S_2 = (3\lambda - 2\frac{1}{2}\lambda) = \frac{1}{2}\lambda,$$

and for a point on nodal line number 2,

$$P_2S_1 - P_2S_2 = 1\frac{1}{2}\lambda,$$

and so on.

$$P_3S_1 - P_3S_2 = 2\frac{1}{2}\lambda.$$

(Note: in the diagram, only  $P_1$  and  $P_2$  are shown.)

In general,

$$P_nS_1 - P_nS_2 = (n - \frac{1}{2})\lambda.$$

That is, the line from  $P_1$  to  $S_1$  is longer by  $(n - \frac{1}{2})\lambda$ .

(A student template for this activity can be found in Appendix 1.7: Interference Pattern from Two Point Sources.)

**Senior Years Science Teachers' Handbook Activities**

Students use the Compare and Contrast Frame for constructive and destructive interference.

**SUGGESTIONS FOR ASSESSMENT****Pencil-and-Paper Tasks**

Students diagram interference patterns and label nodal and antinodal lines.

Students identify areas of constructive and destructive interference from two point sources, and draw in nodal and antinodal lines.

**Group/Peer Assessment**

Students produce a written task for a partner where questions on different interference patterns are posed as well as questions on calculations of path difference. Rubrics for evaluation have to be negotiated in advance.

**SUGGESTED LEARNING RESOURCES****Multimedia**

Cinema Classics videodisc Disk D: Waves (11), Chapter 11, Water Waves—Ripple Tank

**Applets (Websites)**

<<http://socrates.berkeley.edu/~cywon/>>

<<http://www.mta.ca/faculty/science/physics/suren/Applets.html>>

<<http://www.physicsweb.com>> [waves in two dimensions]



## NOTES



---

## TOPIC 1.3: Sound

Students will be able to:

- S3P-1-17 Investigate to analyze and explain how sounds are produced, transmitted, and detected, using examples from nature and technology.  
*Examples: production of sound by a vibrating object, drums, guitar strings, cricket, hummingbird, dolphin, piezocrystal, speakers...*
- S3P-1-18 Use the decision-making process to analyze an issue related to noise in the environment.  
*Examples: sonic boom, traffic noise, concert halls, loudspeakers, leaf blowers...*
- S3P-1-19 Design, construct (or assemble), test, and demonstrate a technological device to produce, transmit, and/or control sound waves for a useful purpose.  
*Examples: sound barrier or protective headphones to reduce the effects of noise, electromagnetic speakers, echo chamber, microphone, musical instruments, guitar pickup, electronic tuner, sonar detector, anechoic chamber, communication devices...*
- S3P-1-20 Describe and explain in qualitative terms what happens when sound waves interact (interfere) with one another.  
Include: production of beats
- S3P-1-21 Experiment to analyze the principle of resonance and identify the conditions required for resonance to occur.  
Include: open- and closed-column resonant lengths
- S3P-1-22 Experiment to calculate the speed of sound in air.
- S3P-1-23 Compare the speed of sound in different media, and explain how the type of media and temperature affect the speed of sound.
- S3P-1-24 Explain the Doppler effect, and predict in qualitative terms the frequency change that will occur for a stationary and a moving observer.
- S3P-1-25 Define the decibel scale qualitatively, and give examples of sounds at various levels.
- S3P-1-26 Describe the diverse applications of sound waves in medical devices, and evaluate the contribution to our health and safety of sound-wave-based technologies.  
*Examples: hearing aid, ultrasound, stethoscope, cochlear implants...*
- S3P-1-27 Explain in qualitative terms how frequency, amplitude, and wave shape affect the pitch, intensity, and quality of tones produced by musical instruments.  
Include: wind, percussion, stringed instruments
- S3P-1-28 Examine the octave in a diatonic scale in terms of frequency relationships and major triads.
-

**GENERAL LEARNING OUTCOME CONNECTION**

*Students will...*

**Understand essential life structures and processes pertaining to a wide variety of organisms, including humans (GLO D1)**

**SPECIFIC LEARNING OUTCOME**

**S3P-1-17:** Investigate to analyze and explain how sounds are produced, transmitted, and detected, using examples from nature and technology.

*Examples: production of sound by a vibrating object, drums, guitar strings, cricket, hummingbird, dolphin, piezocrystal, speakers...*

**SUGGESTIONS FOR INSTRUCTION**

**Entry-Level Knowledge**

The phenomenon of sound is a part of the student's everyday sensory experience. The previous units on characteristics of waves are the basis for understanding the nature of sound. Sound is also an excellent topic to address many varied STSE applications, ranging from noise pollution to music.

**Notes to the Teacher**

Most sounds are waves produced by vibrations. The vibrating source moves the nearby air particles, sending a disturbance through the surrounding medium as a longitudinal wave. We use our eyes for the detection of light and our ears enable us to detect sound. The compressions of sound waves cause the eardrum to vibrate, which, in turn, sends a signal to the brain. There are many interesting experiences that students will have with sound. Ask students if they have ever heard the ocean in a seashell. Actually, the sounds they hear in a seashell are outside noises that resonate in the shell, creating the illusion of hearing the ocean.

Sound waves can be demonstrated in class with a tuning fork. The tines of the tuning fork are struck with a mallet and, as they vibrate back and forth, they disturb surrounding air molecules in a series of compressions and rarefactions. The propagation of these waves is very similar to longitudinal waves in a coil spring toy like a Slinky™. A sound wave can be represented mathematically as a transverse wave with the crests corresponding to regions of high pressure and the troughs corresponding to regions of low pressure.

**Note:** Even though the wave is represented mathematically as a transverse wave, sound is physically a longitudinal wave.

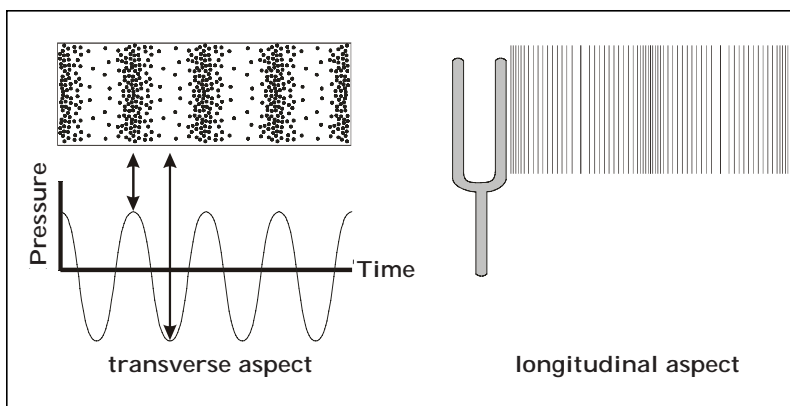

**SKILLS AND ATTITUDES OUTCOMES**

S3P-0-4b: Work cooperatively with a group to identify prior knowledge, initiate and exchange ideas, propose problems and their solutions, and carry out investigations.

S3P-0-4c: Demonstrate confidence in their ability to carry out investigations in science and to address STSE issues.

S3P-0-4e: Demonstrate a continuing and more informed interest in science and science-related issues.

**GENERAL LEARNING OUTCOME CONNECTION**

*Students will...*

**Demonstrate curiosity, skepticism, creativity, open-mindedness, accuracy, precision, honesty, and persistence, and appreciate their importance as scientific and technological habits of mind (GLO C5)**

**SUGGESTIONS FOR INSTRUCTION****Demonstrations**

Strike a tuning fork, and then place it on a sound box, piece of wood, or the top of a musical instrument such as a violin or an acoustic guitar. Often we cannot see the tines of the tuning fork vibrate because the frequency is very high. When we place the tuning fork on another surface, the vibrations are transmitted to that surface and the sound is amplified.

Place the vibrating tuning fork in a beaker of water or near a suspended pith ball to demonstrate a transfer of energy.

Hold a steel strip or plastic ruler in place at the edge of a table. Pull the free end to one side, and then release it to demonstrate the oscillations necessary to produce waves. Although we cannot hear the air movement, there is a displacement of the air particles as the sound is transmitted to our ears.

Sound waves are mechanical waves; that is, they can only be transmitted in a medium. We can use a ringing bell in a vacuum jar to illustrate that as the medium (air) is removed, the sound disappears.

***Senior Years Science Teachers' Handbook Activities***

Students use Rotational Cooperative Graffiti, page 3.15, to describe sound, its production, transmission, and detection.

**SUGGESTIONS FOR ASSESSMENT****Class Discussion**

Students describe how compressions and rarefactions are formed.

Students describe how the vibration of an object is linked to the compressions and rarefactions of longitudinal waves.

**Research Report**

Students research how animals in nature make different sounds. Many animals use sounds as a defense mechanism by shaking a rattle, by scratching, by beating wings, or by vocalizing.

Students research how sound is produced in nature (e.g., a cricket, a hummingbird, or a dolphin).

Students provide some examples to illustrate the detection of sound (e.g., human ear, microphone, oscilloscope).

**Class Discussion**

Students identify the source of a sound, explain how the sound is transmitted, and explain how this sound is detected. Students also link the explanation to the concept of waves.



**GENERAL LEARNING OUTCOME CONNECTION**

*Students will...*

**Understand essential life structures and processes pertaining to a wide variety of organisms, including humans (GLO D1)**

**SPECIFIC LEARNING OUTCOME**

**S3P-1-17:** Investigate to analyze and explain how sounds are produced, transmitted, and detected, using examples from nature and technology.

*Examples: production of sound by a vibrating object, drums, guitar strings, cricket, hummingbird, dolphin, piezocrystal, speakers...*

---

**SUGGESTIONS FOR INSTRUCTION**

**Student Activity**

Using a variety of objects, students can produce different sounds and explain how the sound is produced and transmitted. Examples could include a guitar string being plucked, a drum being hit, or air being blown through a straw.

Students can also observe the vibration of an electromagnetic speaker. By placing an object such as a piece of light plywood in front of the speaker, you can feel the vibration of the speaker. You can also place light, non-magnetic particles on a speaker cone to observe their motion.

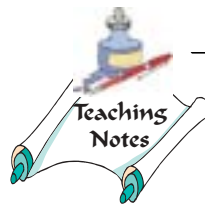



**SKILLS AND ATTITUDES OUTCOMES**

S3P-0-4b: Work cooperatively with a group to identify prior knowledge, initiate and exchange ideas, propose problems and their solutions, and carry out investigations.

S3P-0-4c: Demonstrate confidence in their ability to carry out investigations in science and to address STSE issues.

S3P-0-4e: Demonstrate a continuing and more informed interest in science and science-related issues.

**GENERAL LEARNING OUTCOME CONNECTION**

*Students will...*

**Demonstrate curiosity, skepticism, creativity, open-mindedness, accuracy, precision, honesty, and persistence, and appreciate their importance as scientific and technological habits of mind (GLO C5)**

**SUGGESTIONS FOR INSTRUCTION**

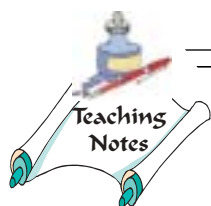

**SUGGESTIONS FOR ASSESSMENT**

**SUGGESTED LEARNING RESOURCES**

**Applets (Websites)**

<<http://www.mta.ca/faculty/science/physics/suren/applets.html>>

<<http://www.kettering.edu/~drussell/forkanim.html>>

This applet shows longitudinal waves produced by a vibrating tuning fork, using particles and areas of high and low pressure.



**GENERAL LEARNING OUTCOME CONNECTION**

*Students will...*

**Understand essential life structures and processes pertaining to a wide variety of organisms, including humans (GLO C3)**

**SPECIFIC LEARNING OUTCOMES**

**S3P-1-18:** Use the decision-making process to analyze an issue related to noise in the environment.

*Examples: sonic boom, traffic noise, concert halls, loudspeakers, leaf blowers...*

**S3P-1-19:** Design, construct (or assemble), test, and demonstrate a technological device to produce, transmit, and/or control sound waves for a useful purpose.

*Examples: sound barrier or protective headphones to reduce the effects of noise, electromagnetic speakers, echo chamber, microphone, musical instruments, guitar pickup, electronic tuner, sonar detector, anechoic chamber, communication devices...*

**SUGGESTIONS FOR INSTRUCTION**

**Notes to the Teacher**

Outcomes S3P.1.18 and S3P.1.19 can be introduced at any time during this topic. They are intentionally placed at the beginning in order to suggest a context for learning about sound. It is suggested that these outcomes be introduced to students at this point and that they guide the investigations into sound that follow. The topic could culminate with the design activity described in outcome S3P.1.19. It is also possible that outcome S3P.1.19 could be combined with the outcomes in the Fields topic on electromagnetism.

**Student Activity**

Using their own experience, students can brainstorm and generate a list of sources of noise in different environments. Then students can investigate ways in which unacceptable noise can be reduced.

Students work in groups to design, construct (or assemble), test, and demonstrate a technological device to produce, transmit, and/or control sound waves for a useful purpose. Examples could include the following.

- Use a 9-volt battery to power a piezoelectric buzzer. Students are challenged to build a device that is no larger than 15 cm x 15 cm x 15 cm to house the buzzer and reduce the noise level. Materials could include cotton batting, foam bits, cardboard, tongue depressors, plastic sandwich bags, et cetera. A variation has each team of students provided with a certain amount of “money” they use to purchase their materials. A rubric can be used to assess the project for effectiveness, economy, and style.
- Students design and build their own musical instruments. They can compare the frequency of the notes on their instruments with an oscilloscope or an electronic tuner. Some students may even be motivated to build quality instruments, such as dulcimers or violins, from readily available kits.
- Students can build a sonar detecting system using an ultrasonic motion detector. The team is required to detect and diagram a hidden landscape using its system.



**SKILLS AND ATTITUDES OUTCOMES**

S3P-0-3c: Identify social issues related to science and technology, taking into account human and environmental needs and ethical considerations.

S3P-0-3d: Use the decision-making process to address an STSE issue.

S3P-0-4c: Demonstrate confidence in carrying out scientific investigations and in addressing STSE issues.

S3P-0-4e: Demonstrate a continuing and more informed interest in science and science-related issues.

**GENERAL LEARNING OUTCOME CONNECTION**

*Students will...*

**Demonstrate appropriate critical thinking and decision-making skills when choosing a course of action based on scientific and technological information (GLO C4)**

**SUGGESTIONS FOR INSTRUCTION**

**SUGGESTIONS FOR ASSESSMENT**

***Senior Years Science Teachers' Handbook Activity***

Students read a current events article about sound pollution in the city (e.g., should leaf blowers be banned?). They complete an Anticipation Guide before and after reading the article.

**Research Report/Presentation**

Students research and report on how sound devices work to produce, transmit, detect, or reduce sound (e.g., car muffler, concert hall baffles).

**SUGGESTED LEARNING RESOURCES**

**Applets (Websites)**

Keyword Internet Search: build a musical instrument, noise pollution, musical instrument making  
<<http://www.oriscus.com/mi/making.asp>>



**GENERAL LEARNING OUTCOME CONNECTION**

*Students will...*

**Demonstrate a knowledge of, and personal consideration for, a range of possible science- and technology-related interests, hobbies, and careers (GLO B4)**

**SPECIFIC LEARNING OUTCOME**

**S3P-1-20:** Describe and explain in qualitative terms what happens when sound waves interact (interfere) with one another.

Include: production of beats

**SUGGESTIONS FOR INSTRUCTION**

**Notes to the Teacher**

Sound beats are the periodic and repeating fluctuations heard in the intensity of a sound when two sound waves of slightly different frequencies interfere with one another. The sound changes from loud to soft, then loud again, and so on. The diagram below illustrates the wave interference pattern resulting from two waves with slightly different frequencies.

A loud sound is heard when the waves interfere constructively and this corresponds to a peak on the beat pattern. No sound is heard when the waves interfere destructively. The beat frequency is the rate at which the sound alternates from loud to soft and equals the difference in frequency of the two sounds. If two sound waves with frequencies of 440 Hz and 442 Hz interfere to produce beats, a beat frequency of 2 Hz will be heard.

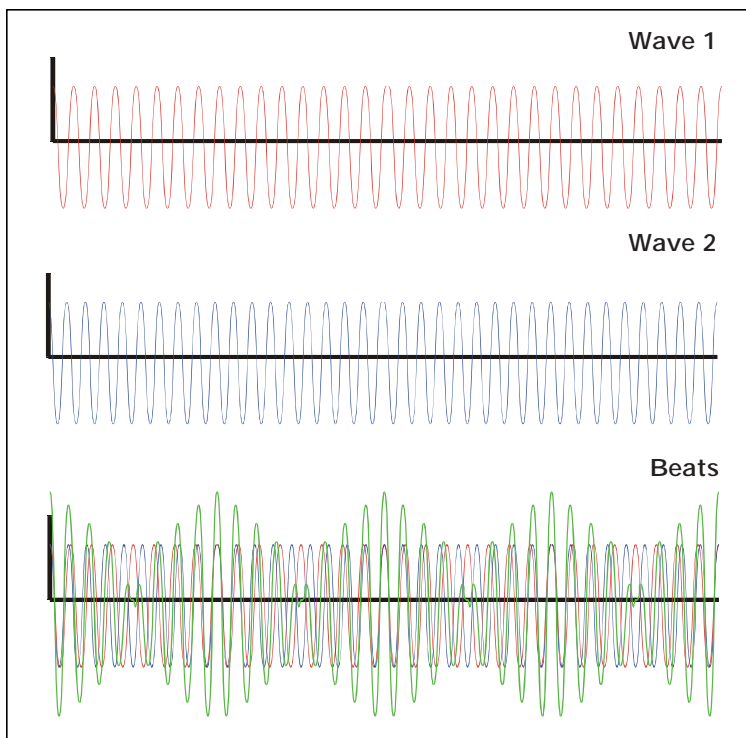

The human ear is only capable of hearing beats with small beat frequencies (e.g., 8 Hz or less). Musicians frequently use beats to tune instruments. If two different sound sources, such as a piano string and a tuning fork, produce detectable beats, then their frequencies are not identical and they are not in tune. The tension of the string is then adjusted until the beats disappear.



**SKILLS AND ATTITUDES OUTCOME**

S3P-0-2f: Record, organize, and display data, using an appropriate format.

Include: labelled diagrams, tables, graphs

**GENERAL LEARNING OUTCOME CONNECTION**

*Students will...*

**Understand how stability, motion, forces, and energy transfers and transformations play a role in a wide range of natural and constructed contexts (GLO D4)**

**SUGGESTIONS FOR INSTRUCTION**

**SUGGESTIONS FOR ASSESSMENT**

**Demonstration**

Beats can be produced in a classroom demonstration using two tuning forks. Strike the forks with a rubber mallet and observe the waves on an oscilloscope. Vary the beat frequency by adjusting the position of a mass on one of the forks.

**Pencil-and-Paper Tasks**

Students label constructive and destructive interference on a diagram.

Students calculate the beat frequency of two tuning forks (or other vibrating sources).

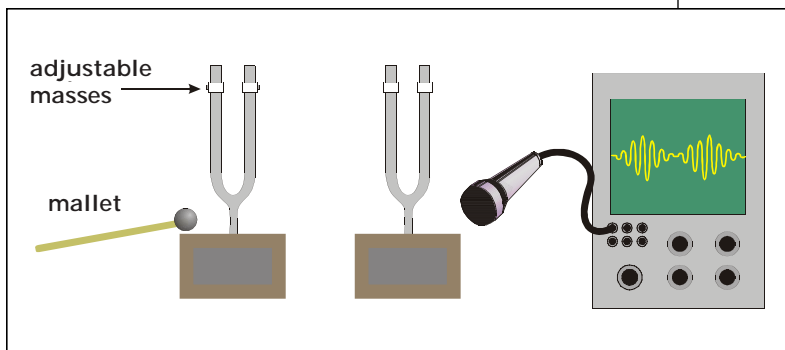

**SUGGESTED LEARNING RESOURCES**

**Applets (Websites)**

<[www.wiley.com/college/howthingswork](http://www.wiley.com/college/howthingswork)>

**Senior Years Science Teachers' Handbook Activities**

Students use Concept Frames to illustrate the characteristics of beats.

<<http://www.physicsweb.com>>

A program can be downloaded to visually demonstrate the production of beats using two transverse waves.

<[http://explorescience.com/activities/activity\\_page.cfm?ActivityID=44](http://explorescience.com/activities/activity_page.cfm?ActivityID=44)>

Hear beats produced for fixed frequencies. Change frequencies and hear the number of beats change.

<<http://www.cs.earlham.edu/~rileyle/Applet.html>>

Adjust the frequency and see the program graphically plot the beats produced.



**GENERAL LEARNING OUTCOME CONNECTION**

*Students will...*

**Demonstrate appropriate scientific inquiry skills when seeking answers to questions (GLO C2)**

**SPECIFIC LEARNING OUTCOME**

**S3P-1-21:** Experiment to analyze the principle of resonance and identify the conditions required for resonance to occur.

Include: open- and closed-column resonant lengths

**SUGGESTIONS FOR INSTRUCTION**

**Notes to the Teacher**

Every object tends to vibrate with a natural frequency. Resonance is the vibrational response of an object to another object that is vibrating at the same natural frequency. Resonance can be illustrated with a number of simple demonstrations.

**Demonstrations**

Suspend several pendula from a tight string. Two of the pendula should be of the same length, and the others of different lengths. Set one of the identical pendula in motion, and soon the other(s) will begin to vibrate in resonance.

Run a moistened fingertip around the edge of a long-stemmed glass and hear the sound produced. This is the resonant frequency. Students can fill up the glass with water and note the resulting sound differences.

**Singing rod:** Hold an aluminum rod exactly in the middle (at a node). Run moistened fingertips up and down the rod to produce a resonance frequency (see diagram).

Two identical tuning forks are mounted on resonance boxes separated by some distance. One of the forks is struck with a mallet. Soon after, the other fork will begin to vibrate in resonance.

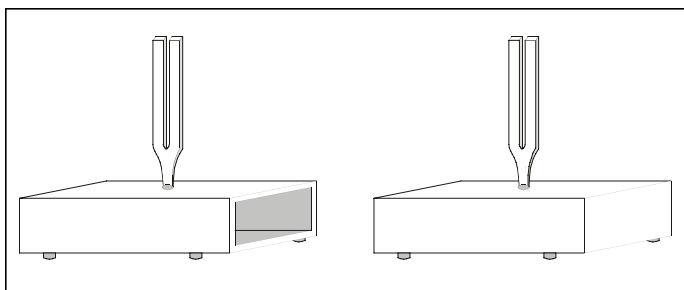

A resonance tube can be used to increase the intensity of the sound from the tuning fork. Suspend a glass tube with its lower end in water and a tuning fork at its upper end. Strike a tuning fork and hold it above the end of the tube (see diagram next page).

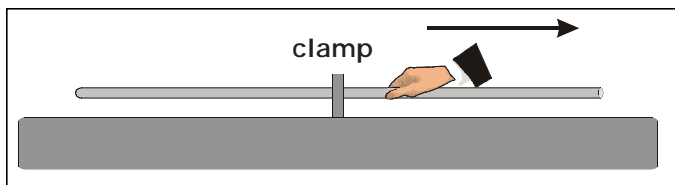

**SKILLS AND ATTITUDES OUTCOMES**

S3P-0-2b: Propose problems, state hypotheses, and plan, implement, adapt, or extend procedures to carry out an investigation.

S3P-0-2d: Estimate and measure accurately, using Système International (SI) units.

S3P-0-2e: Evaluate the relevance, reliability, and adequacy of data and data-collection methods.

Include: discrepancies in data and sources of error

**GENERAL LEARNING OUTCOME CONNECTION**

*Students will...*

**Understand how stability, motion, forces, and energy transfers and transformations play a role in a wide range of natural and constructed contexts (GLO D4)**

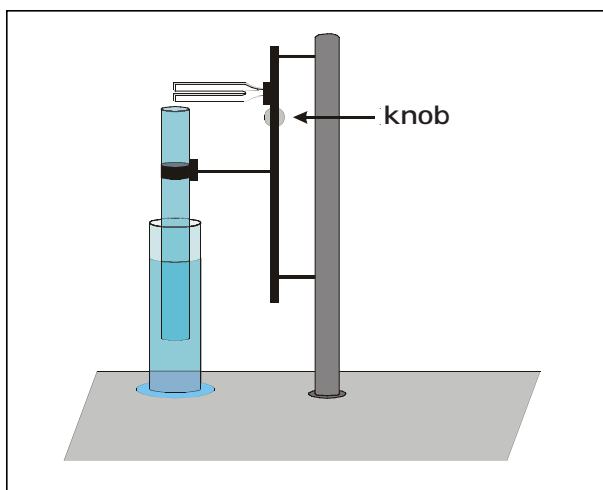
**SUGGESTIONS FOR INSTRUCTION**

The air column is closed at one end and open at the other. If a tuning fork is held over the open end, the loudness increases at specific lengths of the column. Typically, in a demonstration or experiment, the length of the column is changed by adding water (see diagram). The resonant lengths of a closed-air column are  $1/4\lambda$ ,  $3/4\lambda$ ,  $5/4\lambda$ , and so on. Resonance may also be produced on open-air columns such as organ pipes. The resonant lengths of an open-air column are  $1/2\lambda$ ,  $1\lambda$ ,  $3/2\lambda$ , and so on.

**Student Activity**

Using a number of glass test tubes filled with water, students can produce different tunes. Students can also perform a laboratory activity on resonance in open and closed pipes.

**SUGGESTIONS FOR ASSESSMENT****Class Discussion**

A classic in physics: students can view the Tacoma Narrows Bridge collapse and explain the collapse of the bridge (video/DVD).

Students describe the conditions necessary for resonance to occur.

Students compare and contrast resonance in open- and closed-air columns.

**Pencil-and-Paper Tasks**

Students solve problems to calculate resonance length for different frequencies.

**Laboratory Report**

Students describe their observations from their experiment with open- and closed-pipe resonance.

**SUGGESTED LEARNING RESOURCES**

Videodisc (the Tacoma Narrows Bridge Collapse)

Conceptual Physics Alive: Sound II



**GENERAL LEARNING OUTCOME CONNECTION**

*Students will...*

**Demonstrate appropriate scientific inquiry skills when seeking answers to questions (GLO C2)**

**SPECIFIC LEARNING OUTCOMES**

**S3P-1-22:** Experiment to calculate the speed of sound in air.

**S3P-1-23:** Compare the speed of sound in different media, and explain how the type of media and temperature affect the speed of sound.

---

**SUGGESTIONS FOR INSTRUCTION**

**Notes to the Teacher**

The speed of a sound wave describes how fast the disturbance is passed through a medium. The speed of sound, like other waves, depends on the properties of the medium. Generally, the speed of sound is fastest in solids, then liquids, and slowest in gases. (See Appendix 1.9: Data Table for Speed of Sound for a data table on the speed of sound in various media.)

Present students with a table of values for the speed of sound in different media and temperatures. They should note that sound travels faster in a solid medium and that sound travels faster in the same medium if the temperature is higher.

Students commonly confuse the concepts of speed and frequency. Carefully differentiate between these two concepts. Help them remember that speed is “how fast” and frequency is “how often.”

**Student Activity**

A good way to begin investigating the speed of sound is with a rough estimate using echoes. Find a large wall in the school and try to determine the time between a loud noise, such as the clap of your hands or some wooden blocks, and its echo. The time will be very fast, so first try an estimation. You could also try repeatedly clapping so that the sound and the echo are in phase. In this way, you can find the time for 10 claps. Using the appropriate distance, calculate the speed of sound (see Suggested Learning Resources).

The resonance experiment can be used to accurately calculate the speed of sound.

Another experiment to calculate the speed of sound can be performed with a microphone and an oscilloscope or CBL probe and associated program. Place the microphone at the end of a long (3 m) carpet tube. Connect the microphone to the oscilloscope and snap your fingers. The oscilloscope will record the snap and its echo as peaks on the screen. Use these peaks to determine the time it took the sound to travel twice the length of the tube.





**SKILLS AND ATTITUDES OUTCOMES**

S3P-0-2d: Estimate and measure accurately, using Système International (SI) units.

S3P-0-2e: Evaluate the relevance, reliability, and adequacy of data and data-collection methods.

Include: discrepancies in data and sources of error

S3P-0-2g: Interpret patterns and trends in data, and infer or calculate linear relationships among variables.

**GENERAL LEARNING OUTCOME CONNECTION**

*Students will...*

**Understand the properties and structures of matter as well as various common manifestations and applications of the actions and interactions of matter (GLO D3)**

**SUGGESTIONS FOR INSTRUCTION**

**SUGGESTIONS FOR ASSESSMENT**

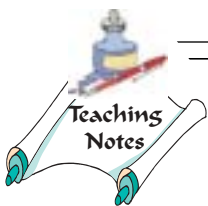

**Teacher Observations**

Students experimentally determine the speed of sound.

**Class Discussion**

Students explain how the type of medium and the temperature of a medium affect the speed of sound.

**Pencil-and-Paper Tasks**

Students solve problems for calculating the speed of sound in air and for calculating spacing between resonances in open and closed pipes.

**SUGGESTED LEARNING RESOURCES**

**Multimedia**

*Video Encyclopedia of Physics Demonstrations* (1992) videodisc, Chapter 24, Properties of Sound

**Software**

Physics with CBL Experiment 24: Speed of Sound (Vernier, 1998)

**Student Activity**

CBL Experiment 24: Speed of Sound (Vernier, 1998)



**GENERAL LEARNING OUTCOME CONNECTION**

*Students will...*

**Demonstrate appropriate scientific inquiry skills when seeking answers to questions (GLO C2)**

**SPECIFIC LEARNING OUTCOME**

**S3P-1-24:** Explain the Doppler effect, and predict in qualitative terms the frequency change that will occur for a stationary and a moving observer.

**SUGGESTIONS FOR INSTRUCTION**

**Notes to the Teacher**

The Doppler effect can be observed when the source of waves is moving with respect to the observer. There is an apparent upward shift in frequency when the observer and the source are approaching each other and an apparent downward shift in frequency when the observer and the source are moving away from each other. Students will be most familiar with the Doppler effect from emergency vehicles such as police and ambulance sirens. As the vehicle approaches with its siren blasting, the pitch (frequency) of the siren will be higher. After the vehicle passes the observer, the pitch (frequency) of the siren sound will be lower.

Note that the Doppler effect is not an actual change in the frequency of the source. The source of the sound always emits the same frequency. The observer only perceives a different frequency because of the relative motion between them.

**Demonstration**

Embed a buzzer in a foam ball and swing it around in a circle.

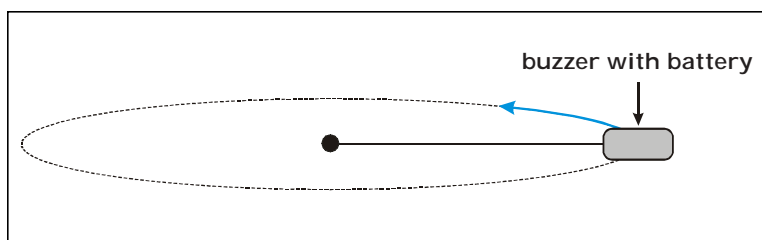

Use diagrams to illustrate the frequency differences that occur when an object approaches, meets, and passes by an observer.

***Senior Years Science Teachers' Handbook Activities***

Students use Three-Point Concept Frames for the Doppler effect and shock waves.



**SKILLS AND ATTITUDES OUTCOME**

S3P-0-2b: Propose problems, state hypotheses, and plan, implement, adapt, or extend procedures to carry out an investigation.

**GENERAL LEARNING OUTCOME CONNECTION**

*Students will...*

**Understand how stability, motion, forces, and energy transfers and transformations play a role in a wide range of natural and constructed contexts (GLO D4)**

**SUGGESTIONS FOR INSTRUCTION**

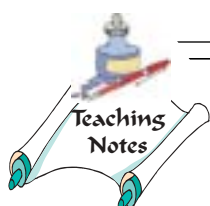

**SUGGESTIONS FOR ASSESSMENT**

**Class Discussion**

Students predict the frequency changes that occur in the Doppler effect and will explain these changes.

**Pencil-and-Paper Tasks**

Students diagram the frequency changes that occur in the Doppler effect.

**Research Report/Presentation**

Students research and report on the application of the Doppler effect in radar and ultrasound imaging.

**SUGGESTED LEARNING RESOURCES**

**Applets (Websites)**

<<http://www.walter-fendt.de/ph11e>>  
This is an animation of a car approaching and then passing an observer.



**GENERAL LEARNING OUTCOME CONNECTION**

*Students will...*

**Identify the factors that affect health and explain the relationships among personal habits, lifestyle choices, and human health, both individual and social (GLO B3)**

**SPECIFIC LEARNING OUTCOME**

**S3P-1-25:** Define the decibel scale qualitatively, and give examples of sounds at various levels.

---

**SUGGESTIONS FOR INSTRUCTION**

**Notes to the Teacher**

The vibration of an object produces a sound wave by forcing the surrounding air molecules into an alternating pattern of compressions and rarefactions. Energy, which is carried by the wave, is imparted to the medium by the vibrating object. The amount of energy that is transferred to the medium depends on the amplitude of the original vibration. For example, if more energy is put into plucking a guitar string, more work is done displacing the string a greater amount and the string vibrates with a larger amplitude.

The intensity of a sound wave is the energy that is transported past a given area per unit of time. If the amplitude of a vibration increases, the rate at which energy is transported also increases. Consequently, the sound wave is more intense. As a sound wave carries its energy through a medium, the intensity of the sound wave decreases as the distance from the source increases. The decrease in intensity can be explained by the fact that the wave is spreading out over a larger surface area.

The scale used to measure the intensity of sound is the decibel scale. The decibel scale is not a linear scale. It is based on multiples of 10 since human hearing can detect a large range of intensities. The threshold of hearing is assigned a sound level of 0 decibels (0 dB) and a sound that is 10 times more intense is assigned a sound level of 10 dB. A sound that is 100 times more intense ( $10^2$ ) is assigned a sound level of 20 dB. A sound that is 1000 times more intense ( $10^3$ ) is assigned a sound level of 30 dB, and so on. (A table showing the intensity levels and examples of each is included in Appendix 1.10: Sound Intensity Levels Table.)

**Student Activity**

Play music (in mono) from a tape recorder through a pair of stereo speakers. Think how the speakers should be arranged to produce sounds of different intensities.



**SKILLS AND ATTITUDES OUTCOMES**

S3P-0-3c: Identify social issues related to science and technology, taking into account human and environmental needs and ethical considerations.

S3P-0-2c: Formulate operational definitions of major variables or concepts.

**GENERAL LEARNING OUTCOME CONNECTION**

*Students will...*

**Identify and demonstrate actions that promote a sustainable environment, society, and economy, both locally and globally (GLO B5)**

**SUGGESTIONS FOR INSTRUCTION**

**SUGGESTIONS FOR ASSESSMENT**

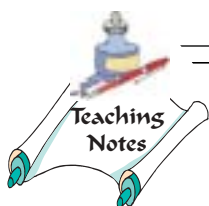

A large empty rectangular box for writing suggestions for instruction.

**Class Discussion**

Students interpret a table of sound intensity levels and use it to associate common sounds/noises.

**Research Report/Presentation**

Students research noise pollution and make suggestions on how to reduce it.



**GENERAL LEARNING OUTCOME CONNECTION**

*Students will...*

**Describe scientific and technological developments, past and present, and appreciate their impact on individuals, societies, and the environment, both locally and globally (GLO B1)**

**SPECIFIC LEARNING OUTCOME**

**S3P-1-26:** Describe the diverse applications of sound waves in medical devices, and evaluate the contribution to our health and safety of sound-wave-based technologies.

*Examples: hearing aid, ultrasound, stethoscope, cochlear implants...*

**SKILLS AND ATTITUDES OUTCOMES**

S3P-0-2i: Select and integrate information obtained from a variety of sources.

Include: print, electronic, and/or specialist sources, resource people

---

**SUGGESTIONS FOR INSTRUCTION**

Many students use their physics to advance to medical careers. The histories of the stethoscope, hearing aids, and ultrasound are very rich and inspiring for these students. Today, many medical devices use the physics of sound as a diagnostic tool and a method of treatment. The use of sound in medical technology has its roots in the military development of sonar. Sonar is the technique of sending out sound waves and observing their echoes to characterize submerged objects. Early ultrasound investigators explored ways to apply sonar to medical diagnosis.

**Student Activity**

Students investigate an application of sound waves in a medical device and evaluate the contribution of this device to the medical field.

**Collaborative Teamwork**

Students can work in research teams to report on the following people's contributions to the development of medical devices employing the principles of sound.

- René T.H. Laennec
- Samuel H. Maslak
- Ian Donald
- Alexander Graham Bell



**SKILLS AND ATTITUDES OUTCOMES**

S3P-0-3a: Analyze, from a variety of perspectives, the risks and benefits to society and the environment when applying scientific knowledge or introducing technology.

S3P-0-4e: Demonstrate a continuing and more informed interest in science and science-related issues.

S3P-0-4d: Develop a sense of personal and shared responsibility for the impact of humans on the environment, and demonstrate concern for social and environmental consequences of proposed actions.

**GENERAL LEARNING OUTCOME CONNECTION**

*Students will...*

**Recognize that scientific and technological endeavours have been and continue to be influenced by human needs and the societal context of the time (GLO B2)**

**SUGGESTIONS FOR INSTRUCTION**

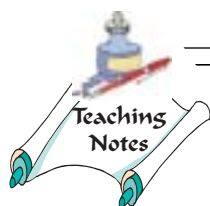

**SUGGESTIONS FOR ASSESSMENT**

**Visual Displays**

Students prepare a poster presentation and gallery walk on the historical development of medical devices that use the physics of sound as their basis of operation.

**Research Report/Presentation**

Students prepare a presentation on the contributions of René T.H. Laennec, Samuel H. Maslak, Ian Donald, and Alexander Graham Bell to the development of medical devices.

**Group/Peer Assessment**

Presentations can be evaluated using rubrics negotiated in advance.

**SUGGESTED LEARNING RESOURCES**

Internet Search Keywords: history of hearing aids, ultrasound, stethoscope  
 <<http://www.pbs.org/wnet/soundandfury/index.html>>  
 Sound and Fury homepage, excellent resource on the ear and cochlear implants (includes animations).

<<http://www.ob-ultrasound.net/history.html>>  
 A short history of the development of ultrasound in obstetrics and gynecology by Dr. Joseph Woo.



**GENERAL LEARNING OUTCOME CONNECTION**

*Students will...*

**Demonstrate a knowledge of, and personal consideration for, a range of possible science- and technology-related interests, hobbies, and careers (GLO B4)**

**SPECIFIC LEARNING OUTCOME**

**S3P-1-27:** Explain in qualitative terms how frequency, amplitude, and wave shape affect the pitch, intensity, and quality of tones produced by musical instruments.

Include: wind, percussion, stringed instruments

---

**SUGGESTIONS FOR INSTRUCTION**

**Notes to the Teacher**

Most musical instruments consist of a vibrating source and a structure to enhance the sound through mechanical and acoustical resonance. A stringed instrument consists of a vibrating string and a resonating sound board or hollow box. Wind instruments contain either open- or closed-air columns of vibrating air; the initial vibration is created by a reed or by the player's lips. Percussion instruments involve striking one object against the other. Students can examine and explain how a variety of musical instruments (e.g., string instruments, percussion instruments, wind instruments) produce sound.

For wind instruments, the length and shape of the resonating air column determines the quality of the sound. Blowing harder can produce a second standing wave or a second harmonic. For string instruments, students can change the length of the vibrating string and note the change in pitch. Plucking the string harder produces a larger vibration and an increase in sound intensity. Pluck the string at different positions along the length of the string to hear the change in harmonics. Resonating boxes amplify the sound. The shape of the resonating box (e.g., guitar versus violin) determines the quality of tones produced.

For percussion instruments, students can strike a drum at various places to note the different pitch produced. Similar objects of different size (e.g., tuning forks) also vibrate at different frequencies.

**Student Activity**

Students can perform the Singing Straw experiment. Suck a liquid up into a straw and hold it there with your tongue. Pull the straw out of the liquid and pinch the bottom. Now remove your tongue from the straw and blow across the top of the straw. At the same time, slowly release your grip on the bottom of the straw. You should hear a change in pitch as the liquid drains out the bottom of the straw.





**SKILLS AND ATTITUDES OUTCOMES**

S3P-0-4b: Work cooperatively with a group to identify prior knowledge, initiate and exchange ideas, propose problems and their solutions, and carry out investigations.

S3P-0-4e: Demonstrate a continuing and more informed interest in science and science-related issues.

S3P-0-2i: Select and integrate information obtained from a variety of sources.  
Include: print, electronic, and/or specialist sources, resource people

**GENERAL LEARNING OUTCOME CONNECTION**

*Students will...*

**Describe and appreciate the similarity and diversity of forms, functions, and patterns within the natural and constructed world (GLO E1)**

**SUGGESTIONS FOR INSTRUCTION**

**Hoot Tubes:** Insert a wire screen in an open-ended glass tube. Heat the end with the screen. The tube hoots when it is removed from the flame. The sound stops when the tube is held horizontally.

**Demonstration**

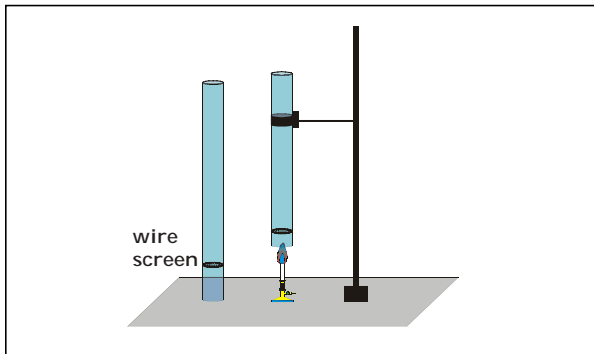

**Senior Years Science Teachers' Handbook Activities**

Students research and report on a family of musical instruments (see *Senior Years Science Teachers' Handbook*, Chapter 14).

Students use Compare and Contrast Frames: Students can compare and contrast instruments that are similar in structure but different in sound: violin versus bass fiddle, horn versus tuba, small bell versus a larger bell.

Students can compare the frequency of the sounds produced by each instrument.

**SUGGESTIONS FOR ASSESSMENT**

**Class Discussions**

Students identify the type of musical instrument and how this instrument produces sound.

Students explain, in qualitative terms, how frequency and pitch are related, how amplitude and intensity of sound are related, and how wave shape and quality of tone are related.

**Performance Assessment**

Students design and build a musical instrument (see outcome S3P.1.19).

**SUGGESTED LEARNING RESOURCES**

**Multimedia**

Physics: Cinema Classics (video/DVD)

**Software**

Exploring Physics and Math with the CBL System (Texas Instruments, 1994)

Student Activity: CBL Lab Activity 26: Nature of Sound (Texas Instruments)

**References**

Internet Search Keywords: physics of music

*The Science of Sound* (Thomas Rossing, 1990)



**GENERAL LEARNING OUTCOME CONNECTION**

*Students will...*

**Demonstrate a knowledge of, and personal consideration for, a range of possible science- and technology-related interests, hobbies, and careers (GLO B4)**

**SPECIFIC LEARNING OUTCOME**

**S3P-1-28:** Examine the octave in a diatonic scale in terms of frequency relationships and major triads.

**SUGGESTIONS FOR INSTRUCTION**

There are many different musical scales. Of them all, the diatonic is the most basic. Any three notes whose vibration frequency ratios are 4, 5, and 6 will produce a major chord (triad). A diatonic scale consists of three sets of major triads. Within an octave, three major triads can be constructed as follows:

C	D	E	F	G	A	B	C <sup>1</sup>	D <sup>1</sup>
4		5		6				
			4		5		6	
				4		5		6

Physicists commonly use a frequency of 256 Hz for middle C. In terms of frequency, in order to reach the higher C (above middle C), we simply double the frequency; that is, middle C is 256 Hz and the next higher C is at 512 Hz. The other frequencies can be found from the 4, 5, 6 ratios. For example:

$$C = 256 \text{ Hz}$$

$$E = 256 \times \frac{5}{4}$$

$$\therefore E = 320 \text{ Hz}$$

**Student Activity**

Using the frequency ratio of 4, 5, 6, students calculate the frequency for each note in the diatonic scale. From these calculations, we find that the note A = 426.6 Hz. Musicians typically use A = 440 Hz. Interested students might want to research the various types of musical scales that make adjustments in the frequencies so that the notes are equally spaced apart and different instruments can play together (i.e., chromatic and equal tempered scales).

**Chromatic scale:** consists of C, C#, D, D#, E, F, F#, G, G#, A, A#, B, and C (all intervals in the chromatic scale are *halftones or semitones*).

The **tempered scale** is a scale in which there is a constant change of frequency between notes.

**Teacher or Student Demonstration**

Play examples of music from different cultures (e.g., Eastern music) and compare the frequency changes between the notes.



**SKILLS AND ATTITUDES OUTCOMES**

S3P-0-2c: Formulate operational definitions of major variables or concepts.

S3P-0-2g: Interpret patterns and trends in data, and infer or calculate linear relationships among variables.

S3P-0-4e: Demonstrate a continuing and more informed interest in science and science-related issues.

**GENERAL LEARNING OUTCOME CONNECTION**

*Students will...*

**Describe and appreciate the similarity and diversity of forms, functions, and patterns within the natural and constructed world (GLO E1)**

**SUGGESTIONS FOR INSTRUCTION**

**SUGGESTIONS FOR ASSESSMENT**

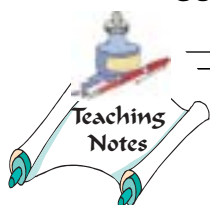

Teaching Notes

**Pencil-and-Paper Tasks**

Students complete Compare and Contrast Frames for fretted and non-fretted instruments.

Given a frequency for a specific note, students determine the frequency of the tone one or two octaves above the specific note and/or one or two octaves below the specific note.

Given a frequency, students determine the frequencies of the major triad.

**Research Report/Presentation**

Students research and report on the musician's equal tempered scale.

**SUGGESTED LEARNING RESOURCES**

*Physics for a Modern World* (Alan Hirsch, 1986)

*The Science of Sound* (Thomas Rossing, 1990)



## NOTES



---

## ***TOPIC 2: THE NATURE OF LIGHT***

2.1: Models, Laws, and Theories

2.2: The Wave and Particle Models of Light

---

## TOPIC 2: THE NATURE OF LIGHT

An understanding of the nature of science is often stated as a fundamental goal in science education (see, for instance, the *Pan-Canadian Science Framework*). However, it is rarely explicitly addressed in science teaching. In this unit, the characteristics of models, laws, and theories are written as student learning outcomes in the context of understanding the historical confrontation between the wave and particle models of light.

The five specific learning outcomes of Topic 2.1: Models, Laws, and Theories could, at the discretion of the instructor, be addressed (or revisited) at other points in the Senior 3 Physics course. These learning outcomes have been placed with Topic 2 to explicitly link the nature of science to episodes from the history of physics.

### Topics

2.1: Models, Laws, and Theories

2.2: The Wave and Particle Models of Light

## NOTES



---

## ***TOPIC 2.1: MODELS, LAWS, AND THEORIES***

Students will be able to:

- S3P-2-01 Use a mystery container activity to outline the relationships among observations, inferences, models, and laws.
  - S3P-2-02 Plan and perform an experiment to identify a linear pattern between two variables and state the pattern as a mathematical relationship (law).  
Include: visual, numeric, graphical, and symbolic modes of representation
  - S3P-2-03 Describe the relationships among knowledge claims, evidence, and evidential arguments.  
Include: atomic model of matter, a relevant advertising claim
  - S3P-2-04 Outline the tentative nature of scientific theories.  
Include: speculative and robust theories
  - S3P-2-05 Describe the characteristics of a good theory.  
Include: accuracy, simplicity, and explanatory power
-



**GENERAL LEARNING OUTCOME CONNECTION**

*Students will...*

**Recognize that scientific knowledge is based on evidence, models, and explanations, and evolves as new evidence appears and new conceptualizations develop (GLO A2)**

**SPECIFIC LEARNING OUTCOME**

**S3P-2-01:** Use a mystery container activity to outline the relationships among observations, inferences, models, and laws.

---

**SUGGESTIONS FOR INSTRUCTION**

**Notes to the Teacher**

For background information, refer to “Understanding Models, Laws, and Theories” included in Appendix 2.1: Wave-Particle Model of Light—Models, Laws, and Theories, or see McComas’ article on the “Ten myths of science.”

**Class Activity**

Use a rotational graffiti activity (see *Senior Years Science Teachers’ Handbook*, page 3.21) to tap into students’ prior knowledge of scientific models, laws, and theories.

Questions that students could address in this exercise are:

1. What is a scientific model? Give examples.
2. What is a scientific law? Give examples.
3. What is a scientific theory? Give examples.
4. Is it possible to prove scientific theories?
5. Do you believe in atoms? Why?
6. How are science and art similar and/or different?
7. Some astronomers say the universe is expanding, some say it is shrinking, and others say it is static. How can these scientists arrive at completely different conclusions when they look at the same evidence?
8. Can scientific theories change?

(For more information, see Lederman et al. in the Suggested Learning Resources.)

**Laboratory Activities**

Students use a mystery container and design a model that explains their observations of the movement and sounds of the objects in the container. Students should differentiate between their observations (their sense data) and their inferences (the meaning they assign to their observations). See Appendix 2.2: The Mystery Container for a mystery container activity.

- Observations: Rolling, sliding, clunking noises are heard.
- Inference: A cylinder rolls one way and slides the other.
- Law: Establish the meaning of a scientific law by first noting regular patterns in observations. The statement “whenever I hold the mystery container upright and rotate it to the left, I hear a rolling sound and then a clunk as the object hits the side wall” is a simple qualitative law that has constraints on it (the way you must hold the container).
- Model: There is a metal cylinder inside the container that is free to move.



**SKILLS AND ATTITUDES OUTCOMES**

S3P-0-1a: Explain the roles of theory, evidence, and models in the development of scientific knowledge.

S3P-0-1e: Differentiate between how scientific theories explain natural phenomena and how scientific laws identify regularities and patterns in nature.

**GENERAL LEARNING OUTCOME CONNECTION**

*Students will...*

**Recognize that scientific knowledge is based on evidence, models, and explanations, and evolves as new evidence appears and new conceptualizations develop (GLO A2)**

**SUGGESTIONS FOR INSTRUCTION**

- Prediction of the model: If I rotate the container rapidly, the cylinder should tumble.
- Test the model.

**Teacher Demonstration**

Ask students to extend their understanding of observations, inferences, models, and laws to scientific phenomena that they have previously studied. For example:

- Rub a plastic rod with silk and bring it near a fine stream of water.
- Rub the edge of a stemmed glass with a moistened finger (friction creates a standing wave in glass that increases in intensity).
- Recall how an earthquake in Ontario can make glasses in a cupboard in Manitoba move (energy is transmitted from one place to the other in the form of seismic waves).

**Senior Years Science Teachers' Handbook Activities**

Students complete Compare and Contrast Frames using laws and models, observation, and inference.

Students can use Concept Frames to define terms and include examples from science.

**SUGGESTIONS FOR ASSESSMENT**

**Observation**

Students prepare a container containing a mysterious object and exchange it with a partner. Students note in their scientific journals the stages followed to arrive at a model explaining the identity of the object.

**SUGGESTED LEARNING RESOURCES**

See Appendix 2.2: The Mystery Container

**References**

McComas, W.F. (1996) "Ten myths of science: Reexamining what we think we know about the nature of science." *School Science and Mathematics* 96: 10–16.

Lederman, Norm G., Fouad Abd-El-Khalick, Randy L. Bell, Renée S. Schwartz. (June 6, 2002) "Views of nature of science questionnaire: Toward valid and meaningful assessment of learners' conceptions of nature of science." *Journal of Research in Science Teaching* 39.6: 497–521.



**GENERAL LEARNING OUTCOME CONNECTION**

*Students will...*

**Recognize that scientific knowledge is based on evidence, models, and explanations, and evolves as new evidence appears and new conceptualizations develop (GLO A2)**

**Specific Learning Outcome**

**S3P-2-02:** Plan and perform an experiment to identify a linear pattern between two variables and state the pattern as a mathematical relationship (law).

Include: visual, numeric, graphical, and symbolic modes of representation

**SKILLS AND ATTITUDES OUTCOMES**

S3P-0-1e: Differentiate between how scientific theories explain natural phenomena and how scientific laws identify regularities and patterns in nature.

**SUGGESTIONS FOR INSTRUCTION**

**Notes to the Teacher**

The emphasis in Senior 3 Physics is on linear relationships. Students have previously studied linear relationships in Senior 2 mathematics. They should be expected to extend their understanding of concepts such as slope and area to physical relationships.

This is a good time to reinforce the ideas about scientific laws developed in the previous outcome. Students should understand that laws represent patterns in nature, that laws are not absolute, and that they can be constrained by certain conditions such as temperature, pressure, and material.

**Student Activity**

Students reflect on the regularities observed in Senior 2 Science, such as in Newton's Second Law ( $\text{force} \propto \text{mass}$ ) and for braking distance ( $d \propto v^2$ ). Students differentiate between linear and non-linear patterns.

**Student Activity**

Students plan and carry out a simple experiment to determine a linear relation between two variables. The teacher may select from any number of possible experiments. For example:

- Astronomy with a Stick (see Appendix 2.3)
- The lengthening of a spring according to the suspended mass (Hooke's Law)
- The relationship between circumference and diameter of a circle
- The relationship between the metre stick shadow and the height of the stick (should be done from January to May or August to November—see Appendix 2.3: Astronomy with a Stick). The same activity can be performed in groups, where each group takes measurements at different times during the day. Compare the results of each group. Explain the differences in slope of the linear graphs of these relationships.



**SKILLS AND ATTITUDES OUTCOMES**

S3P-0-2a: Select and use appropriate visual, numeric, graphical, and symbolic modes of representation to identify and represent relationships.

S3P-0-2f: Record, organize, and display data, using an appropriate format.

Include: labelled diagrams, tables, graphs

S3P-0-2g: Interpret patterns and trends in data, and infer or calculate linear relationships among variables.

**GENERAL LEARNING OUTCOME CONNECTION**

*Students will...*

**Demonstrate appropriate scientific inquiry skills when seeking answers to questions (GLO C2)**

**SUGGESTIONS FOR INSTRUCTION**

The experimental procedure should be left to the students, who should be able to represent the relationship in the four modes of representation. The teacher acts as a facilitator and re-examines the experimental plan with the pupils and helps them make the necessary modifications.

Students reflect on how scientists use the four modes of representation.

**SUGGESTIONS FOR ASSESSMENT**

**Asking and Answering Questions Based on Data/Performance Assessment**

Students visually, numerically, and graphically represent familiar formulas such as  $A = l \cdot w$ ,  $C = 2\pi \cdot r$ ,  $D = M/V$ ,  $V = l \cdot w \cdot h$ , and  $A = \frac{1}{2} b \cdot h$  (for a constant base).

**Lab Report Assessment**

Laboratory Report Rubric, Appendix 5

**SUGGESTED LEARNING RESOURCES**

Appendix 2.3: Astronomy with a Stick

Appendix 5: Developing Assessment Rubrics in Science



**GENERAL LEARNING OUTCOME CONNECTION**

*Students will...*

**Recognize both the power and limitations of science as a way of answering questions about the world and explaining natural phenomena (GLO A1)**

**SPECIFIC LEARNING OUTCOME**

**S3P-2-03:** Describe the relationships among knowledge claims, evidence, and evidential arguments.

Include: atomic model of matter, a relevant advertising claim

---

**SUGGESTIONS FOR INSTRUCTION**

**Notes to the Teacher**

A knowledge claim is a declaration of conviction consisting of a sentence of the type "I know that..." or "I believe that...." Knowledge claims are supported by evidence whose nature depends on the training and the experiment of the claimer. Evidence can be first-hand observations, deference to authority, or plausible explanations. Deference to authority can range from naive acceptance of the authority to a more careful consideration of evidence. While we would prefer that students generate as much of the evidence as they possibly can, in science it is not always feasible to do so. Experiments need specialized equipment, some experiments are dangerous, and so on. However, we should still encourage students to evaluate the evidential claims made by authority. Is the evidence plausible? Does it relate to my personal experience? Could I do the experiment myself? Can I model the experiment? We wish to address the questions, "What makes us believe?" and "How do I know?"

To be convincing, the claimer must formulate an argument relevant to the intended audience. Sometimes the evidence is given in the form of a critical experiment that is overwhelmingly convincing.

Students examine an example of scientific reasoning drawn from everyday experience. For example, you are discussing carbonated beverages with your friend when she makes the following claim: "I believe that Dr. Pop is the best." You are not convinced and ask her to support her opinion with evidence. To convince you, she should choose evidence that is relevant to you. Her evidence might be based on an authority such as "Céline Dion recommends this product"; it could be statistical data, such as "three out of four people prefer Dr. Pop"; or she could provide a biochemical explanation that this product contains less caffeine and less sugar and is therefore better for one's health. Discuss such examples by underlining the elements of the scientific reasoning.



**SKILLS AND ATTITUDES OUTCOMES**

S3P-0-1d: Describe how scientific knowledge changes as new evidence emerges and/or new ideas and interpretations are advanced.

S3P-0-3b: Describe examples of how technology has evolved in response to scientific advances, and how scientific knowledge has evolved as the result of new innovations in technology.

**GENERAL LEARNING OUTCOME CONNECTION**

*Students will...*

**Recognize that scientific knowledge is based on evidence, models, and explanations, and evolves as new evidence appears and new conceptualizations develop (GLO A2)**

**SUGGESTIONS FOR INSTRUCTION**

**SUGGESTIONS FOR ASSESSMENT**

Follow up the everyday example with a scientific claim students are familiar with from their previous experiences. The atomic model of matter is a good example:

- Knowledge Claim: The atom has a positive nucleus surrounded by negative electrons.
- Evidence: Rutherford's experiment refuted Thomson's plum pudding model. By bombarding a thin gold foil with alpha particles, Rutherford showed that the matter consists of a positive nucleus in a rather large, empty space, surrounded by negative charges. Rutherford's experiment might be considered a critical experiment because it involved the widespread acceptance of this model and the rejection of Thomson's model.

***Senior Years Science Teachers' Handbook Activities***

Students complete Compare and Contrast Frames about evidence and evidential arguments used in science versus evidence and evidential arguments used in legal practice.

**Recognizing the Role of Evidence**

Choose a paragraph in a scientific textbook and ask students to identify a knowledge claim, evidence, and evidential argument. Often the evidence is given in the form of more claims. Students suggest ways these claims can be confirmed.

**SUGGESTED LEARNING RESOURCES**

See Appendix 2.1: Wave-Particle Model of Light—Models, Laws, and Theories

Stinner, A., and H. Williams. (1993) "Conceptual Change, History, and Science Stories." *Interchange* 24.1: 87–103.



**GENERAL LEARNING OUTCOME CONNECTION**

*Students will...*

**Recognize that scientific knowledge is based on evidence, models, and explanations, and evolves as new evidence appears and new conceptualizations develop (GLO A2)**

**SPECIFIC LEARNING OUTCOMES**

**S3P-2-04:** Outline the tentative nature of scientific theories.

Include: speculative and robust theories

**S3P-2-05:** Describe the characteristics of a good theory.

Include: accuracy, simplicity, and explanatory power

**SUGGESTIONS FOR INSTRUCTION**

**Notes to the Teacher**

The word “theory” is used in everyday language to mean many different things, from an idea or hypothesis to a complex explanatory system such as Einstein’s Theory of Relativity. In this outcome, the use of the adjectives “speculative” and “robust” helps to differentiate between a public and a scientific understanding of the word “theory.”

Speculative theories have little supporting evidence but may be useful in defining questions and establishing a research program. A robust theory is a complex explanatory system that may include presuppositions, empirical evidence, novel predictions, models, and scientific laws.

However, it can never really be proven that a theory will cover all possible cases. (There are far too many to check!) Thus, our theories are tentative and could change in the future to accommodate new information and/or new interpretations of old information. Since theories can and do change, history has illustrated that at times we will have competing theories within the scientific community. Then, how do we evaluate a theory? According to Thomas Kuhn, explanatory theories can be

evaluated according to the following criteria (and these are not exhaustive):

- **Accuracy:** Consequences deducible from a theory should agree with existing experiments and observations.
- **Simplicity:** A theory should bring order to phenomena that, in its absence, would be individually isolated and confused.
- **Explanatory Power:** A theory should be consistent with itself and other currently accepted theories. In other words, a theory should not contradict itself or other accepted theories. The consequences of a theory should extend far beyond the particular observations and laws it was initially designed to explain.

In hindsight, we may be inclined to view accuracy as the major selection criterion for theory choice. However, for competing theories, accuracy is a necessary but not usually a sufficient criterion. Copernicus’ heliocentric theory was no more accurate than Ptolemy’s geocentric theory until Kepler revised it more than 60 years later. Additionally, a theory may be more accurate in one area and less in another.



**GENERAL LEARNING OUTCOME CONNECTION**

*Students will...*

**Recognize that scientific knowledge is based on evidence, models, and explanations, and evolves as new evidence appears and new conceptualizations develop (GLO A2)**

**SUGGESTIONS FOR INSTRUCTION**

**SUGGESTIONS FOR ASSESSMENT**

Theories are also judged by their simplicity and consistency. For example, simplicity favoured Copernicus' system but, in terms of consistency, a moving Earth was inconsistent with Aristotle's explanation of motion. However, in terms of scope, Copernicus' theory was able to make novel predictions such as the existence of the phases of Venus (which was not discovered until 50 years later) to extend the scope of the theory.

***Senior Years Science Teachers' Handbook Activities***

Students use a Compare and Contrast Frame to outline speculative and robust theories.

**Recognizing the Role of Evidence**

Students evaluate known theories (atomic models, model of the solar system) using Thomas S. Kuhn's five characteristics of a good theory.

**SUGGESTED LEARNING RESOURCES**

Kuhn, Thomas. (1977) "Objectivity, Value Judgement, and Theory Choice." *The Essential Tension: Selected Studies in Scientific Tradition and Change*. 320–339.





## NOTES



---

## **TOPIC 2.2: PARTICLE AND WAVE MODELS OF LIGHT**

Students will be able to:

- S3P-2-06 Outline several historical models used to explain the nature of light.  
Include: tactile, emission, particle, wave models
- S3P-2-07 Summarize the early evidence for Newton's particle model of light.  
Include: propagation, reflection, refraction, dispersion
- S3P-2-08 Experiment to show the particle model of light predicts that the velocity of light in a refractive medium is greater than the velocity of light in an incident medium ( $v_r > v_i$ ).
- S3P-2-09 Outline the historical contribution of Galileo, Rømer, Huygens, Fizeau, Foucault, and Michelson to the development of the measurement of the speed of light.
- S3P-2-10 Describe phenomena that are discrepant to the particle model of light.  
Include: diffraction, partial reflection and refraction of light
- S3P-2-11 Summarize the evidence for the wave model of light.  
Include: propagation, reflection, refraction, partial reflection/refraction, diffraction, dispersion
- S3P-2-12 Compare the velocity of light in a refractive medium predicted by the wave model with that predicted in the particle model.
- S3P-2-13 Outline the geometry of a two-point-source interference pattern, using the wave model.
- S3P-2-14 Perform Young's experiment for double-slit diffraction of light to calculate the wavelength of light.  
Include:  $\lambda = \frac{\Delta x d}{L}$
- S3P-2-15 Describe light as an electromagnetic wave.
- S3P-2-16 Discuss Einstein's explanation of the photoelectric effect qualitatively.
- S3P-2-17 Evaluate the particle and wave models of light and outline the currently accepted view.  
Include: the principle of complementarity
-

**GENERAL LEARNING OUTCOME CONNECTION**

*Students will...*

**Recognize that scientific knowledge is based on evidence, models, and explanations, and evolves as new evidence appears and new conceptualizations develop (GLO A2)**

**SPECIFIC LEARNING OUTCOME**

**S3P-2-06:** Outline several historical models used to explain the nature of light.

Include: tactile, emission, particle, wave models

---

**SUGGESTIONS FOR INSTRUCTION**

**Notes to the Teacher**

Early models of light were concerned with the source of light. Did light originate in the eyes or did objects emit light? The tactile theory was based on the ability of the eye to "touch objects." According to Plato, light consisted of filaments or streamers coming from the eyes. When these filaments came into contact with an object, sight was established. The emission theory was the opposite of the tactile theory and stated that objects sent out light beams or particles that would ricochet off objects and enter the eye. The emission theory was generally accepted over the tactile theory.

The two most successful theories of light were the corpuscular (or particle) theory of Sir Isaac Newton and the wave theory of Christian Huygens. Newton's corpuscular theory stated that light consisted of particles that travelled in straight lines. Huygens argued that if light were made of particles, when light beams crossed, the particles would collide and cancel each other. He proposed that light was a wave.

At the end of the 19th century, James Clerk Maxwell combined electricity, magnetism, and light into one theory. He called his theory the electromagnetic theory of light. According to Maxwell, light was an electromagnetic wave with the same properties as other electromagnetic waves. Maxwell's theory, however, was unable to explain the photoelectric effect. In 1900, Max Planck suggested that light was transmitted and absorbed in small bundles of energy called "quanta." Albert Einstein agreed with Planck's theory and explained the photoelectric effect using a particle model of light. The quantum theory combines the two major theories of light, suggesting that light does not always behave as a particle and light does not always behave as a wave.



**GENERAL LEARNING OUTCOME CONNECTION**

*Students will...*

**Recognize that scientific knowledge is based on evidence, models, and explanations, and evolves as new evidence appears and new conceptualizations develop (GLO A2)**

**SUGGESTIONS FOR INSTRUCTION**

**SUGGESTIONS FOR ASSESSMENT**

Students can research historical models of light: tactile, emission, particle, and wave models.

Students can discuss the plausibility of each model, the merits of each, and their inconsistencies or basis in the evidence.

**Research Report/Presentation**

Students outline the major features of early models of light, discussing plausibilities and deficiencies of each model.

**SUGGESTED LEARNING RESOURCES**

*PSSC Physics, 6th edition* (Haber-Schaim, Uri, John H. Dodge, and James A. Walter, 1991)



**GENERAL LEARNING OUTCOME CONNECTION**

*Students will...*

**Recognize that scientific knowledge is based on evidence, models, and explanations, and evolves as new evidence appears and new conceptualizations develop (GLO A2)**

**SPECIFIC LEARNING OUTCOMES**

**S3P-2-07:** Summarize the early evidence for Newton's particle model of light.

Include: propagation, reflection, refraction, dispersion

**S3P-2-08:** Experiment to show the particle model of light predicts that the velocity of light in a refractive medium is greater than the velocity of light in an incident medium ( $v_r > v_i$ ).

**SUGGESTIONS FOR INSTRUCTION**

**Notes to the Teacher**

In science, models are used to make predictions about the behaviour of phenomena in the physical world. If the model makes accurate predictions, we accept the model as a valid description of the world. If the model encounters events that are discrepant, we modify the model or use an entirely different model. Throughout history there have been several confrontations between competing models as scientific knowledge developed. A classic example of competing models is reflected in our understanding of the nature of light. In addressing these learning outcomes, students should be able to summarize the evidence and discrepant events for each model.

**The Particle Model of Light Explains Rectilinear Propagation of Light**

Newton used the analogy of a ball to explain the rectilinear motion of light. When a ball is thrown, it describes a parabolic path because of the effect of gravity. In order to follow a straight-line path, the ball must be thrown very quickly. Newton reasoned that particles of light must move at very high speeds.

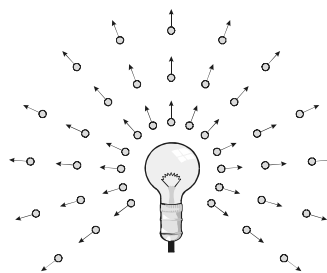

**Demonstration**

**Model:** Throw a baseball slowly and then very fast. At slow speeds, a curvature is easily observed, but at high speeds the ball travels in a straight line.

**Light:** Make a light beam pass through a cloud of chalk dust to observe that light travels in straight lines.

**Reflection of light:** Newton showed that, in an elastic collision between hard spheres, the angle of incidence equals the angle of reflection.

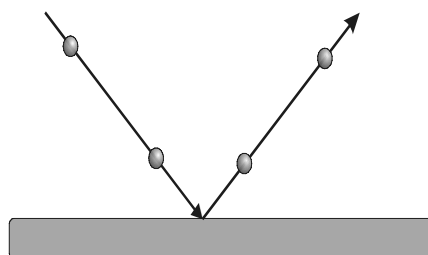

**GENERAL LEARNING OUTCOME CONNECTION***Students will...***Demonstrate appropriate scientific inquiry skills when seeking answers to questions (GLO C2)****SUGGESTIONS FOR INSTRUCTION****SUGGESTIONS FOR ASSESSMENT****Demonstration**

**Model:** Videotape a billiard ball reflecting off a side cushion and then measure the angles of incidence and reflection.

**Light:** Measure the angles of incidence and reflection of light from a mirror.

**Refraction:** Newton explained refraction by comparing the movement of the particles of light with that of a ball descending an inclined plane (see diagram below).

According to Newton, the particles of light will accelerate as they pass from air to water. Newton claimed that water attracted the particles of light, predicting that the speed of light would be faster in water than in air.

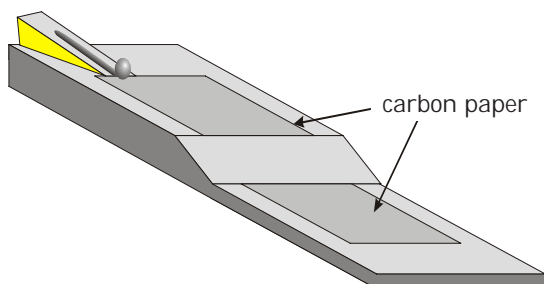
**Class Discussion**

Students state the model and corresponding observation for light.

Students provide examples of supporting evidence for the particle model of light.

**SUGGESTED LEARNING RESOURCES**

*The Best From Conceptual Physics Alive!*  
Videodiscs, Side 3, Chapter 22



**GENERAL LEARNING OUTCOME CONNECTION**

Students will...

Recognize that scientific knowledge is based on evidence, models, and explanations, and evolves as new evidence appears and new conceptualizations develop (GLO A2)

**SPECIFIC LEARNING OUTCOMES**

**S3P-2-07:** Summarize the early evidence for Newton's particle model of light.

Include: propagation, reflection, refraction, dispersion

**S3P-2-08:** Experiment to show the particle model of light predicts that the velocity of light in a refractive medium is greater than the velocity of light in an incident medium ( $v_r > v_i$ ).

**SUGGESTIONS FOR INSTRUCTION**

**Demonstration**

Model: Students can easily reproduce Newton's experiment to show that

$$\frac{\sin\theta_i}{\sin\theta_r} = a \text{ constant, derive (Snell's Law).}$$

Light: Perform an experiment to trace the refraction of light through water, using a cheese box and pins.

**Demonstration**

Light: Light can be dispersed using a prism. Note any visual evidence that the amount of bending in the dispersed light depends upon the colour (or wavelength) of the light.

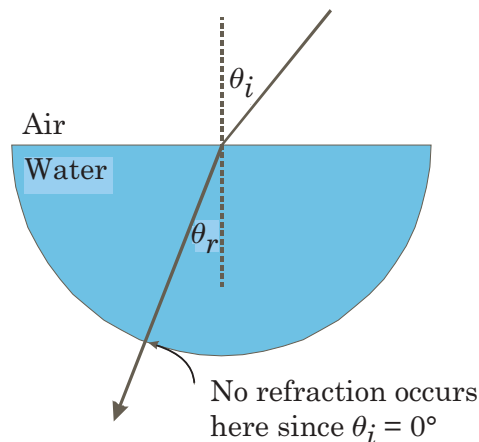
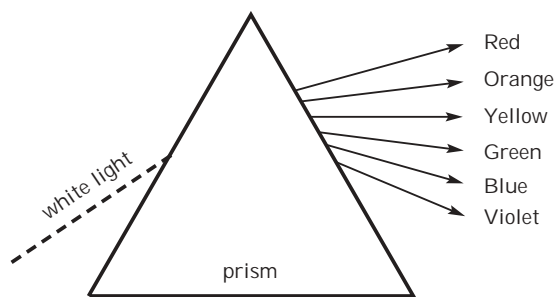

Dispersion: Newton explained dispersion by supposing that the most refracted particles (the violet particles) had a lower mass than the least refracted particles (red particles).



**GENERAL LEARNING OUTCOME CONNECTION**

*Students will...*

**Demonstrate appropriate scientific inquiry skills when seeking answers to questions (GLO C2)**

**SUGGESTIONS FOR INSTRUCTION**

**SUGGESTIONS FOR ASSESSMENT**

**Student Activity**

Place a pair of mirrors on edge with their faces at  $90^\circ$ . Place a coin close to where the mirrors meet. Notice the number of coin images you have. Start decreasing the angle between the mirrors. Notice what happens to the number of coin images. Now place the mirrors parallel to each other, face to face and only a few centimetres apart, with the coin between. Notice the number of images of the coin.

***Senior Years Science Teachers' Handbook Activities***

RAFTS (*Senior Years Science Teachers' Handbook*, page 13.23): Students write a request for subsidy on behalf of Newton outlining the promise of his research.

Students complete a chart to summarize the arguments in favour of Newton's corpuscular theory (see Appendix 2.4: Chart for Evaluating the Models of Light). The students can complete the table as the other concepts are examined.

**Peer Assessment**

Students exchange their summary charts and evaluate arguments in favour of the corpuscular theory of light.

**SUGGESTED LEARNING RESOURCES**

*The Best From Conceptual Physics Alive!*  
Videodiscs, Side 3, Chapter 20





**GENERAL LEARNING OUTCOME CONNECTION**

*Students will...*

**Recognize that scientific knowledge is based on evidence, models, and explanations, and evolves as new evidence appears and new conceptualizations develop (GLO A2)**

**SPECIFIC LEARNING OUTCOME**

**S3P-2-09:** Outline the historical contribution of Galileo, Rømer, Huygens, Fizeau, Foucault, and Michelson to the development of the measurement of the speed of light.

---

**SUGGESTIONS FOR INSTRUCTION**

**Notes to the Teacher**

The particle model of light predicted that the speed of light would be faster in water than in air, and the wave model predicted the opposite. Therefore, the determination of the speed of light was seen to be a critical experiment in order to decide between the wave and particle models of light.

**Student Activity**

Students devise an experiment to determine the speed of the light. What challenges do we face? What observations must we make? What equipment would be necessary?

Students draw up, individually or collectively, a timeline to illustrate the methods used to calculate the speed of light. They can add to the timeline as the unit progresses.

Students use software to illustrate Rømer's method of determining the finite speed of light from the period of the moons of Jupiter. See Appendix 2.10: Simulating Rømer's Eclipse Timings Using *Starry Night Backyard* for a sample procedure.

***Senior Years Science Teachers' Handbook Activities***

Research Project: Students research the contributions of the following scientists to the speed of the light: Galileo, Rømer, Huygens, Fizeau, Foucault, and Michelson. (See Appendix 2.4: Chart for Evaluating the Models of Light.)

Jigsaw Strategy (*Senior Years Science Teachers' Handbook*, page 3.21): Divide the students into groups of "experts" by assigning one of the above scientists to each group. After their research, re-assign the students into mixed groups to share their new knowledge and to get information about the other scientists.



**SKILLS AND ATTITUDES OUTCOMES**

S3P-0-1d: Describe how scientific knowledge changes as new evidence emerges and/or new ideas and interpretations are advanced.

S3P-0-4b: Work cooperatively with a group to identify prior knowledge, initiate and exchange ideas, propose problems and their solutions, and carry out investigations.

**GENERAL LEARNING OUTCOME CONNECTION**

*Students will...*

**Recognize that scientific knowledge is based on evidence, models, and explanations, and evolves as new evidence appears and new conceptualizations develop (GLO A2)**

**SUGGESTIONS FOR ASSESSMENT****Collaborative Teamwork**

Jigsaw Strategy: To ensure the contribution of all the members of the group, each "expert" devises questions for the other members.

**Visual Display/Research Report**

From their research, students create a poster, including complete name, year of birth and death, nationality, method, observations, inferences, conclusions, and speed of light.

**Illustrative Example**

Complete name: Galileo Galilei

Year of birth and death: 1564–1642

Nationality: Italian

Method: Galileo and his assistant placed themselves on distant hills approximately one kilometre apart. When the assistant saw the light of Galileo's lantern, he was to light his lantern.

Observations: Reaction time was too long.

Inferences: Galileo concluded that light moves too quickly to calculate its speed in this manner.

**Class Discussion**

Students use information about the historical development of the measurement of the speed of light to show how science advances technology, and how technology advances science.

**SUGGESTED LEARNING RESOURCES**

*Starry Night Backyard*, <[www.space.com](http://www.space.com)> (also available from the Manitoba Text Book Bureau (Stock # 8420) at <<http://www.edu.gov.mb.ca/ks4/docs/mtbb/>>)

Appendix 2.6: Ole Christensen Rømer: The First Determination of the Finite Nature of the Speed of Light

Appendix 2.7: Ole Rømer and the Determination of the Speed of Light

Appendix 2.9: Becoming Familiar with Ionian Eclipses

Appendix 2.10: Simulating Rømer's Eclipse Timings Using *Starry Night* Software

Appendix 2.11: Contributions to the Determination of the Speed of Light



**GENERAL LEARNING OUTCOME CONNECTION**

*Students will...*

**Recognize that scientific knowledge is based on evidence, models, and explanations, and evolves as new evidence appears and new conceptualizations develop (GLO A2)**

**SPECIFIC LEARNING OUTCOME**

**S3P-2-10:** Describe phenomena that are discrepant to the particle model of light.

---

**SUGGESTIONS FOR INSTRUCTION**

**Notes to the Teacher**

Newton's particle model of light was weak in explaining partial reflection and refraction of light and diffraction. Questions also arose about propagation of light. If light were a particle, how could light beams pass through each other without scattering?

**Teacher Demonstration**

Partial reflection and refraction: Use a ray box and a glass block. As you rotate the glass block, the light ray will partially reflect and partially refract. At the critical angle, the light ray will totally reflect.

Newton explained this property of light by proposing a theory of "fits," according to which the particles of light arriving at the border of two mediums passed by access to easy reflection or access to easy refraction. In other words, the particles of light must somehow alternately reflect and refract. Ask students, "How, in partial reflection, does a particle know if it should reflect or refract?" Even Newton acknowledged that his explanation of partial reflection and refraction was insufficient.

Diffraction is the term used to describe the spreading of light at the edges of an obstacle. Newton's corpuscular theory provided no adequate explanation of diffraction. Newton tried to explain diffraction through interactions and collisions between the particles of light and the edges of very narrow slits engraved on glass plates. (See diagram in Topic 2.2, page 28, for an analog.) However, no predictions could be made that could be tested and measured empirically.

**Student Demonstration**

Students look at a light through a thin slit created by bringing together two fingers (one observes black lines parallel with the fingers, which are interference patterns resulting from diffraction).

**Senior Years Science Teachers' Handbook Activities**

RAFTS Assignment: Students write a letter on behalf of the committee of subsidies to refuse Newton's application for subsidy by explaining the problems with his research.



**SKILLS AND ATTITUDES OUTCOME**

S3P-0-1d: Describe how scientific knowledge changes as new evidence emerges and/or new ideas and interpretations are advanced.

**GENERAL LEARNING OUTCOME CONNECTION**

*Students will...*

**Recognize that scientific knowledge is based on evidence, models, and explanations, and evolves as new evidence appears and new conceptualizations develop (GLO A2)**

**SUGGESTIONS FOR INSTRUCTION**

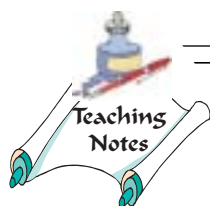

A large empty rectangular box for writing teaching notes.

**SUGGESTIONS FOR ASSESSMENT**

**Group/Peer Assessment**

Students complete the chart to summarize the arguments disputing Newton's corpuscular model (see Appendix 2.4: Chart for Evaluating the Models of Light).

Students prepare a report of laboratory experiments designed by them to investigate the particle model of light.

**SUGGESTED LEARNING RESOURCES**

*Senior Years Science Teachers' Handbook Activities (RAFTS)*



**GENERAL LEARNING OUTCOME CONNECTION**

*Students will...*

**Recognize that scientific knowledge is based on evidence, models, and explanations, and evolves as new evidence appears and new conceptualizations develop (GLO A2)**

**SPECIFIC LEARNING OUTCOMES**

**S3P-2-11:** Summarize the evidence for the wave model of light.

Include: propagation, reflection, refraction, partial reflection/refraction, diffraction, dispersion

**S3P-2-12:** Compare the velocity of light in a refractive medium predicted by the wave model with that predicted in the particle model.

**SUGGESTIONS FOR INSTRUCTION**

**Notes to the Teacher**

Discuss the evaluation of the two models of light in terms of Kuhn's characteristics of a good theory.

- Accuracy: Do observations match the prediction of the model?
- Simplicity: Is the model simple to understand? Do some explanations begin to get complicated (e.g., Newton's explanation of diffraction)?
- Explanatory Power: How much does each model explain? Are there any contradictions within the model?

Students should have a good understanding of the properties of waves from the first topic. Students compare the properties of waves and the properties of light.

**Propagation**

Huygens thought of light rays as the direction of travel of the wave (wave ray).

**Reflection**

It can be demonstrated using water waves that the angle of incidence is equal to the angle of reflection for waves.

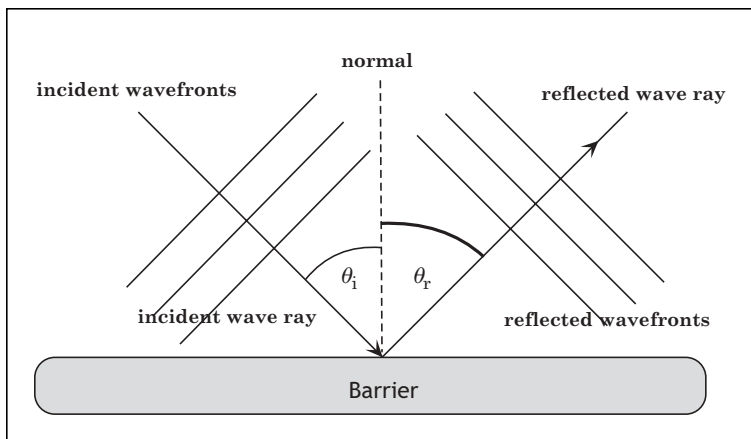

**Refraction**

While passing from the air to water, a light ray deviates towards the normal. Huygens' wave theory explained this deviation by proposing that the speed of the wave decreases in the heavier medium. Snell's Law can be derived from Huygens' geometry. Huygens' model predicts that the speed of light is less in water than in air. This explanation goes against Newton, who predicted that the speed of light is greater in water. Thus, determining the speed of light becomes a "critical experiment," which provides definitive support for one theory and eliminates the other.



**SKILLS AND ATTITUDES OUTCOME**

S3P-0-1d: Describe how scientific knowledge changes as new evidence emerges and/or new ideas and interpretations are advanced.

**GENERAL LEARNING OUTCOME CONNECTION**

*Students will...*

**Recognize that scientific knowledge is based on evidence, models, and explanations, and evolves as new evidence appears and new conceptualizations develop (GLO A2)**

**SUGGESTIONS FOR INSTRUCTION**

**SUGGESTIONS FOR ASSESSMENT**

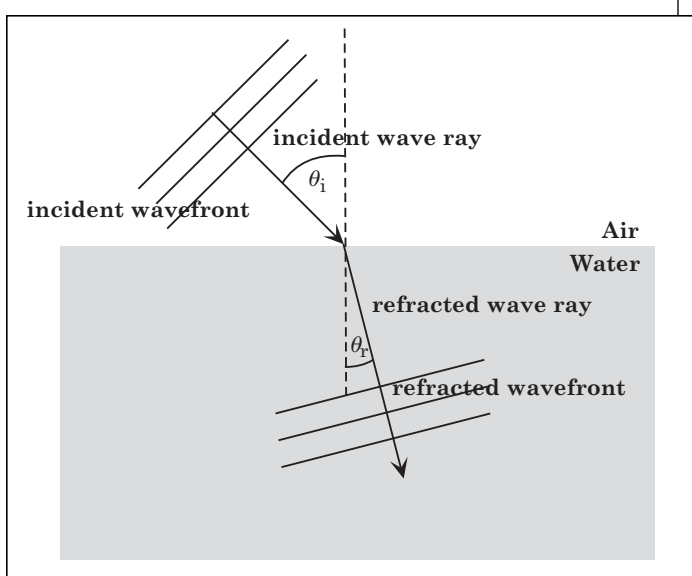

Students evaluate each model according to its capacity to explain the behaviour of the light (see Appendix 2.4: Chart for Evaluating the Models of Light).

**Partial Reflection/Refraction**

When one varies the angle of incidence of a wave passing from one medium to another, part of the wave is reflected and part is refracted. In the particular case where the wave passes from a slow medium to a fast medium, there is a critical angle where the entire wave is reflected. This phenomenon is called internal total reflection.

**SUGGESTED LEARNING RESOURCES**

**References**

Appendix 2.4: Chart for Evaluating the Models of Light



**GENERAL LEARNING OUTCOME CONNECTION**

*Students will...*

**Recognize that scientific knowledge is based on evidence, models, and explanations, and evolves as new evidence appears and new conceptualizations develop (GLO A2)**

**SPECIFIC LEARNING OUTCOMES**

**S3P-2-11:** Summarize the evidence for the wave model of light.

Include: propagation, reflection, refraction, partial reflection/refraction, diffraction, dispersion

**S3P-2-12:** Compare the velocity of light in a refractive medium predicted by the wave model with that predicted in the particle model.

**SUGGESTIONS FOR INSTRUCTION**

**Diffraction**

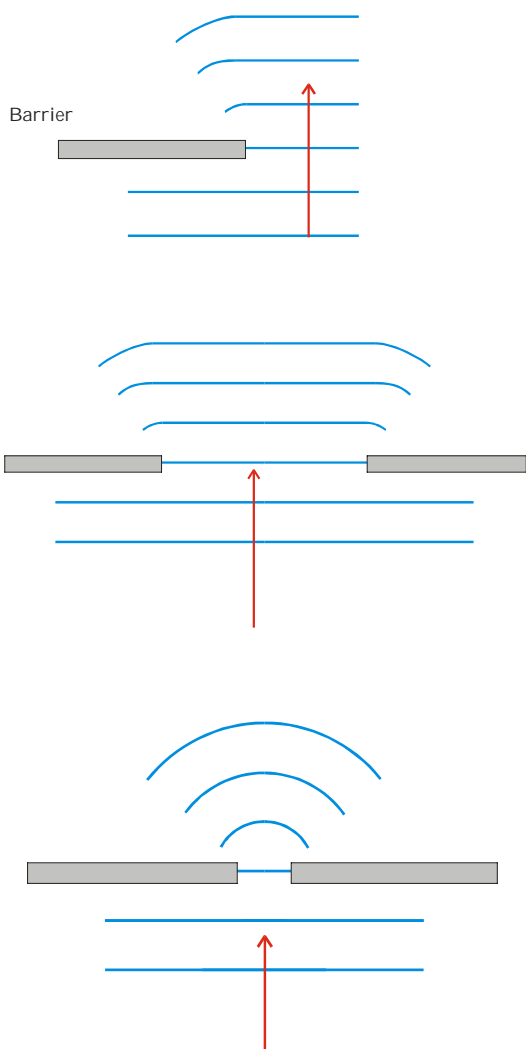

When a wave passes by a barrier, it bends (diffraction). If the wave passes through two barriers, both ends bend. If the opening is narrow enough (compared to the wavelength), the waves will emerge as circular waves. In this way, as waves pass through two thin slits, a pattern of constructive and destructive interference occurs.

A similar pattern of interference occurs with light. When two crests or two troughs meet, light is enhanced and a bright area can be seen. When a crest meets a trough, destructive interference occurs and a dark area is seen. The interference pattern shows up as a series of alternating light and dark bands.

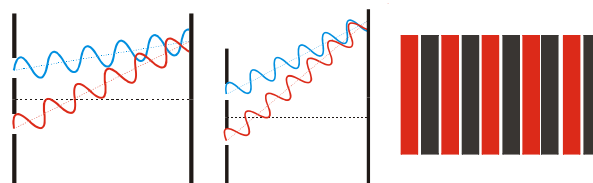

**Poisson's Spot:** When light is diffracted around a spherical object (like a steel ball bearing), a bright spot appears in the middle of the diffraction pattern. There is an interesting story behind the discovery of Poisson's Spot. In 1818, Augustin Fresnel presented a paper on the theory of



**SKILLS AND ATTITUDES OUTCOME**

S3P-0-1d: Describe how scientific knowledge changes as new evidence emerges and/or new ideas and interpretations are advanced.

**GENERAL LEARNING OUTCOME CONNECTION**

*Students will...*

**Recognize that scientific knowledge is based on evidence, models, and explanations, and evolves as new evidence appears and new conceptualizations develop (GLO A2)**

**SUGGESTIONS FOR INSTRUCTION**

**SUGGESTIONS FOR ASSESSMENT**

diffraction to the French Academy. Contrary to Newton's corpuscular model, Fresnel's theory represented light as a wave. Siméon Poisson, a member of the judging committee for the competition, was very critical of the wave theory of light. Using Fresnel's own theory, Poisson deduced that light diffracted around a circular obstacle would produce a bright spot behind the object. Poisson believed that this was an absurd outcome that falsified Fresnel's theory. However, another member of the judging committee, Dominique Arago, produced the spot experimentally and Fresnel won the competition.

***Senior Years Science Teachers' Handbook Activities***

Students compare and contrast the properties of the waves and light.

**Demonstration of the Major Explanatory Stories of Science**

**RAFTS:** Students write an article that Newton would have written to a scientific review (such as *Science and Life*, *Géo*, or *Discover*) to explain why his particle model is superior to the wave model with regard to the behaviour of the light. Students also write the reply that Huygens would have formulated to defend his model.





**GENERAL LEARNING OUTCOME CONNECTION**

*Students will...*

**Demonstrate appropriate scientific inquiry skills when seeking answers to questions (GLO C2)**

**SPECIFIC LEARNING OUTCOMES**

**S3P-2-13:** Outline the geometry of a two-point-source interference pattern, using the wave model.

**S3P-2-14:** Perform Young's experiment for double-slit diffraction of light to calculate the wavelength of light.

Include:  $\lambda = \frac{\Delta x d}{L}$

**S3P-2-15:** Describe light as an electromagnetic wave.

**SUGGESTIONS FOR INSTRUCTION**

**Notes to the Teacher**

The mathematical analysis of the interference of two point sources from the wave topic can be applied to light that diffracts through two narrow slits.

Derive Young's equation by making a connection to the geometry of two-point sources. Students then carry out Young's experiment to determine the wavelength of light for various colours.

**Student Activity**

Provide students with the following instructions:

Hold two fingers close together between your eye and a bright source. Look at the narrow opening and observe diffraction fringes. Vary the width of the opening and the distance of your fingers from your eye, and note the effects.

This is a qualitative demonstration of the relationship  $\lambda = \frac{\Delta \times d}{L}$ .



**GENERAL LEARNING OUTCOME CONNECTION**

*Students will...*

**Demonstrate appropriate scientific inquiry skills when seeking answers to questions (GLO C2)**

**SUGGESTIONS FOR INSTRUCTION**

**SUGGESTIONS FOR ASSESSMENT**

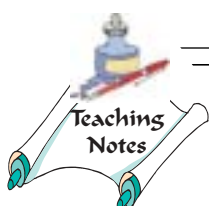

*(This area is intentionally left blank for teaching notes.)*

Students re-examine their evaluation of the particle and wave models of light, and modify it according to their new knowledge (see Appendix 2.4: Chart for Evaluating the Models of Light).

**Science Journal Entries**

Students reflect on Young's experiment in their scientific notebooks. Their reflection can be based on the following questions:

Why are there dark lines? (They result from the destructive interference.)

Why are there bright lines? (They result from the constructive interference.)

Would the distance between the nodal lines be larger for the red light ( $\lambda = 680 \text{ nm}$ ) or the blue light ( $\lambda = 400 \text{ nm}$ )? Why?

What would occur at the distance between the nodal lines:

- if one doubled the distance between the slits?
- if one doubled the length between the slits and the screen?

**SUGGESTED LEARNING RESOURCES**

**Applets (Websites)**

<http://webphysics.ph.msstate.edu/jc/library/24-3b/index.html>

An excellent applet that allows the user to change the parameters of Young's experiment.



**GENERAL LEARNING OUTCOME CONNECTION**

*Students will...*

**Understand how stability, motion, forces, and energy transfers and transformations play a role in a wide range of natural and constructed contexts (GLO D4)**

**SPECIFIC LEARNING OUTCOME**

**S3P-2-16:** Discuss Einstein's explanation of the photoelectric effect qualitatively.

**SUGGESTIONS FOR INSTRUCTION**

**Notes to the Teacher**

Heinrich Hertz noticed that when certain metal surfaces are exposed to an ultraviolet light, negative charges are emitted from the metal. How can we explain the emission of negative charges, using the particle and wave models of light? Discuss the predictions of the wave and particle models with respect to the photoelectric effect.

To dislodge an electron of a metal surface, it is necessary to communicate a certain quantity of energy to the electron.

**Prediction of the Wave Model**

The wave model predicts that the energy distributed along the wave will eventually build up and release a package of electrons at the same time. According to the wave model, light of any frequency should demonstrate the photoelectric effect. Lower frequencies would just take longer to build up enough energy to release the electrons. A low frequency wave with high intensity should eventually be able to dislodge an electron. This, however, is not the case. Only certain frequencies emit electrons. The wave model fails to accurately predict the photoelectric phenomenon.

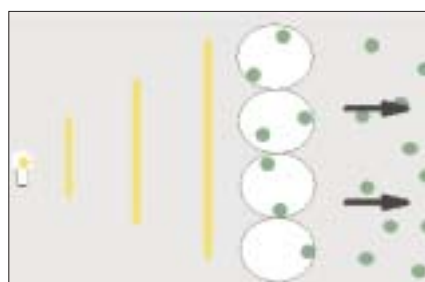
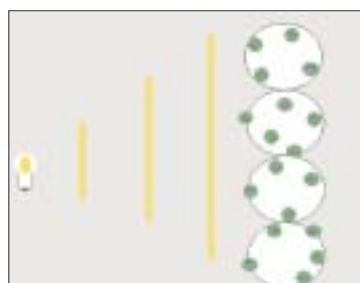

**Prediction of the Particle Model**

Einstein proposed that light consists of packets of energy called "photons," and that the quantity of energy of each photon is fixed and depends on its frequency. Thus, the particle model predicts that individual photons knock out electrons and that only photons with enough energy (above the threshold frequency) can do this.



**GENERAL LEARNING OUTCOME CONNECTION**

*Students will...*

**Understand how stability, motion, forces, and energy transfers and transformations play a role in a wide range of natural and constructed contexts (GLO D4)**

**SUGGESTIONS FOR INSTRUCTION**

**SUGGESTIONS FOR ASSESSMENT**

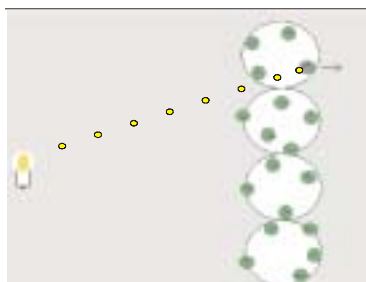

The photoelectric effect can be illustrated with a video.

Students complete a word splash to examine the vocabulary related to the nature of science.

***Senior Years Science Teachers' Handbook Activities***

Students compare and contrast the wave and particle model's ability to explain the photoelectric effect.

Students draw up flow charts or conceptual cards to consolidate their comprehension of the vocabulary related to the nature of science and the models seeking to explain light.

**Science Journal Entries**

Students plot a Venn diagram that illustrates the properties of light that are well explained by either one of the models, or by both.



**GENERAL LEARNING OUTCOME CONNECTION**

*Students will...*

**Recognize both the power and limitations of science as a way of answering questions about the world and explaining natural phenomena (GLO A2)**

**SPECIFIC LEARNING OUTCOME**

**S3P-2-17:** Evaluate the particle and wave models of light and outline the currently accepted view.

Include: the principle of complementarity

---

**SUGGESTIONS FOR INSTRUCTION**

**Notes to the Teacher**

As we evaluate the predictions of the particle and wave models of light, we find that each model explains some phenomena and each model has difficulty explaining other phenomena. Initially, we thought that the determination of the speed of light and the explanation of diffraction were critical experiments that eliminated the particle model in favour of the wave model.

However, the photoelectric effect seems to do the opposite: it favours the particle model and cannot be explained by the wave model. This brings up the question: "Can there ever be a critical experiment that eliminates one theory and favours another?" The answer is that there is no such thing as a critical experiment because some other explanation could always exist. It is obvious that light is not just a particle or a wave. Light has a dual nature, a property that physicists call the wave-particle duality of light. We cannot draw pictures or visualize this duality. As humans, we are restricted to thinking only about particles and waves independently.

Niels Bohr, the Danish physicist, declared in his principle of complementarity that, "to understand a specific experiment, one must use either the wave or photon theory but not both." To understand light, one must understand the characteristics of both particles and waves. The two aspects of light complement each other.



**GENERAL LEARNING OUTCOME CONNECTION**

*Students will...*

**Evaluate, from a scientific perspective, information and ideas encountered during investigations and in daily life (GLO C8)**

**SUGGESTIONS FOR INSTRUCTION**

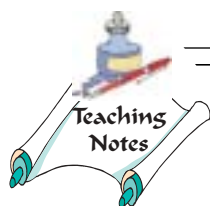

Empty box for teaching notes.

**SUGGESTIONS FOR ASSESSMENT**

**Class Discussion**

Students explain Bohr's quote, "to understand a specific experiment, one must use either the wave or photon theory but not both."

**SUGGESTED LEARNING RESOURCES**

*The Best From Conceptual Physics Alive!*  
Videodiscs, Side 4, Chapter 12



## NOTES



---

## ***TOPIC 3: MECHANICS***

3.1: Kinematics 5

3.2: Dynamics 27

---



## **TOPIC 3: MECHANICS**

---

In order to achieve a more complete understanding of kinematics and dynamics, these topics are developed across Senior 2, 3, and 4. The approach is intentionally developmental. In Senior 2 Science, students are introduced to kinematics and dynamics of motion, using the context of the automobile. The treatment is mostly qualitative as students are introduced to the concepts and terminology of force and motion. In Senior 3 Physics, these ideas are revisited with an emphasis on a quantitative understanding, especially with respect to graphic and symbolic representations of motion. A thorough treatment of the linear relationships should help students acquire a more in-depth understanding of kinematics and dynamics. In Senior 4 Physics, the special equations of motion and the special situations in motion, such as projectiles and circular motion, will complete this developmental approach.

### **Topics**

3.1: Kinematics

3.2: Dynamics

## NOTES



---

## TOPIC 3.1: KINEMATICS

The student will be able to:

S3P-3-01: Differentiate between, and give examples of, scalar and vector quantities.

*Examples: distance, speed, mass, time, temperature, volume, weight, position, displacement, velocity, acceleration, force...*

S3P-3-02: Differentiate among position, displacement, and distance.

S3P-3-03: Differentiate between the terms "an instant" and "an interval" of time.

S3P-3-04: Analyze the relationships among position, velocity, acceleration, and time for an object that is accelerating at a constant rate.

Include: transformations of position-time, velocity-time, and acceleration-time graphs using slopes and areas

S3P-3-05: Compare and contrast average and instantaneous velocity for non-uniform motion.

Include: slopes of chords and tangents

S3P-3-06: Illustrate, using velocity-time graphs of uniformly accelerated motion,

that average velocity can be represented as  $\vec{V}_{avg} = \frac{\Delta \vec{d}}{\Delta t}$  and that

displacement can be calculated as  $\Delta \vec{d} = \frac{\vec{v}_1 + \vec{v}_2}{2} \Delta t$ .

S3P-3-07: Solve problems, using combined forms of:

$$\vec{V}_{avg} = \frac{\vec{v}_1 + \vec{v}_2}{2}, \vec{V}_{avg} = \frac{\Delta \vec{d}}{\Delta t}, \vec{a}_{avg} = \frac{\Delta \vec{v}}{\Delta t}.$$

---

**GENERAL LEARNING OUTCOME CONNECTION**

*Students will...*

**Understand how stability, motion, forces, and energy transfers and transformations play a role in a wide range of natural and constructed contexts (GLO D4)**

**SPECIFIC LEARNING OUTCOMES**

**S3P-3-01:** Differentiate between, and give examples of, scalar and vector quantities.

*Examples: distance, speed, mass, time, temperature, volume, weight, position, displacement, velocity, acceleration, force...*

**S3P-3-02:** Differentiate among position, displacement, and distance.

---

**SUGGESTIONS FOR INSTRUCTION**

**Entry-Level Knowledge**

In Senior 2 Science, students studied motion along a straight line. Vector directions were described only as forward and backward (S2-3-01, S2-3-02, S2-3-03).

**Notes to the Teacher**

The treatment of vectors is intentionally developmental, progressing from a qualitative approach in Senior 2 Science to more complex representations in Senior 3 and Senior 4 Physics. In Senior 3 Physics, students describe, add, and subtract vectors on a straight line and at right angles, using algebra and the Pythagorean theorem. The graphical method of adding and subtracting vectors is a useful introduction to the mathematical solution. In Senior 4 Physics, students will add and subtract vectors at any angle, using components.

A scalar is a quantity that represents magnitude only, whereas a vector is a quantity that has magnitude and direction.

Vectors can be introduced using position/distance/displacement examples. Position is the location of an object and requires a distance and direction from a known origin. The choice of the origin is arbitrary; however, the origin must be known by all. Distance is the length of the path travelled and displacement is the object's change in position.

Extend the vector concepts introduced in Senior 2 Science by using compass directions. First, use straight-line motion and then motion at right angles. Compare the concepts of position, distance, and displacement.

**Illustrative Example 1**

A woman begins at an origin and walks 4 m east, then 3 m west. What is her final position? (1 m east) What is her distance travelled? (7 m) What is the final displacement of the motion? (1 m east) Repeat the motion with the woman beginning at a position 2 m east of the chosen origin. What is her final position? (3 m east) What is her distance travelled? (7 m) What is the displacement of the motion? (1 m east)



**SKILLS AND ATTITUDES OUTCOME**

S3P-0-2h: Analyze problems, using vectors.

Include: adding and subtracting vectors in straight lines and at right angles, vector components

**SUGGESTIONS FOR INSTRUCTION**

**Illustrative Example 2**

A man begins at an origin, then walks 4 m east, then 3 m north. What is his final position? (5 m  $37^\circ$  north of east) What is his distance travelled? (7 m) What is the final displacement of the motion? (5 m,  $37^\circ$  north of east)

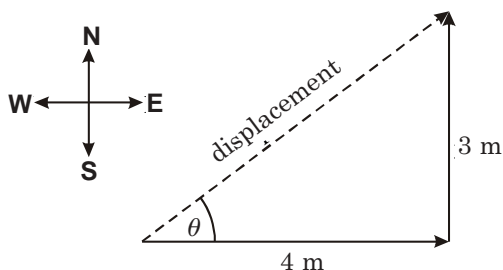

The direction for a vector may be described in a number of ways:

1. Common terms such as left/right, up/down, forward/backward
2. Compass directions (north/south/east/west)
3. Number line, using positive and negative signs (+/-)
4. Coordinate system, using angles of rotation from the horizontal axis

**SUGGESTIONS FOR ASSESSMENT**

**Performance Assessment**

Students engage in a scavenger hunt in the park, a field, or in the classroom, making use of vectors to locate an object or place.

**Science Journal Entries**

Students demonstrate results of a “vector journey” through labelled vector diagrams and a short story.

**SUGGESTED LEARNING RESOURCES**

Nelson, J. (1983) “Kinematics of a Student.” *The Physics Teacher* 21.6: 386.

Appendix 3.2: A Vector Journey

Appendix 3.3: Journal Entry on Vectors

Appendix 3.4: A Vector Sampler

Appendix 3.6: Describing Motion in Various Ways

**GENERAL LEARNING OUTCOME CONNECTION**

*Students will...*

**Understand how stability, motion, forces, and energy transfers and transformations play a role in a wide range of natural and constructed contexts (GLO D4)**

**SPECIFIC LEARNING OUTCOMES**

**S3P-3-01:** Differentiate between, and give examples of, scalar and vector quantities.

*Examples: distance, speed, mass, time, temperature, volume, weight, position, displacement, velocity, acceleration, force...*

**S3P-3-02:** Differentiate among position, displacement, and distance.

---

**SUGGESTIONS FOR INSTRUCTION**

**Note:** There are many different notations that are used to represent direction on direction finders. It is recommended that teachers refer to their physics and math texts to decide on a convenient strategy.

**Teacher Demonstration**

Attach a cone to the end of an elastic band, and fix the other end of the elastic band to something solid. The elastic can be stretched to imitate various lengths and directions of vectors.

**Senior Years Science Teachers' Handbook Activities**

Divide the class into groups. Each group prepares a list of situations in which knowledge of distance moved would be valuable, and a list of situations in which knowledge of displacement moved would be valuable. Students present their lists to the class. The following are possible examples: distance is valuable in determining fuel consumption for vehicles, wear and tear on vehicles, or the amount of exercise from jogging; displacement (distance and direction) is necessary to go from one location to another.

Students tell a vector story (your trek to school) that includes reference to an origin, magnitudes, and directions.

Students tell a vector story from a different frame of reference (e.g., a person walks 2.0 m/s backward on a bus moving past you at 10 m/s).

Using a Three-Point Approach Frame, students define and illustrate terminologies related to vectors (see Appendix 3.3: Journal Entry on Vectors).



**SKILLS AND ATTITUDES OUTCOME**

S3P-0-2h: Analyze problems, using vectors.

Include: adding and subtracting vectors in straight lines and at right angles, vector components

---

**SUGGESTIONS FOR INSTRUCTION**

**SUGGESTIONS FOR ASSESSMENT**

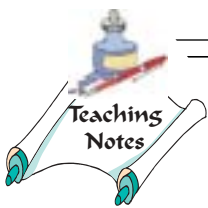

--	--

--	--

**GENERAL LEARNING OUTCOME CONNECTION**

*Students will...*

**Understand how stability, motion, forces, and energy transfers and transformations play a role in a wide range of natural and constructed contexts (GLO D4)**

**SPECIFIC LEARNING OUTCOME**

**S3P-3-03:** Differentiate between the terms “an instant” and “an interval” of time.

---

**SUGGESTIONS FOR INSTRUCTION**

**Entry-Level Knowledge**

Students may have some limited experience from mathematics.

**Notes to the Teacher**

The notion of time is important in physics. A common misconception is that an instant in time is a very short interval of time. However, an instant is considered to be a single clock reading ( $t$ ). If time were plotted on an axis, an instant is just a single coordinate along that axis. An interval is a duration in time (i.e., the interval separating two instants on the time axis [ $\Delta t$ ]). The combination of a clock reading and instantaneous position is called an event, a concept that later becomes useful when introducing relativity.

**Note:**  $\Delta$ , pronounced “delta,” is used to represent the phrase “change in,” and is calculated as “final – initial.”

e.g.,  $\Delta t$  is read as: the change in time

$$(\Delta t = t_{final} - t_{initial})$$

$\Delta v$  is read as: the change in velocity

$$(\Delta v = v_{final} - v_{initial})$$

**Class Activity**

Students time a runner at regular intervals and make a data table of the time “splits” (i.e., the time at 10-m intervals). From the table, note the instantaneous time and the time intervals.

***Senior Years Science Teachers’ Handbook Activities***

Students use a Concept Frame for instant and interval of time.





**SKILLS AND ATTITUDES OUTCOME**

S3P-0-2c: Formulate operational definitions of major variables or concepts.

**SUGGESTIONS FOR INSTRUCTION**

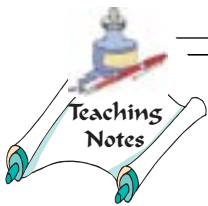

**SUGGESTIONS FOR ASSESSMENT**

**Asking and Answering Questions Based on Data**

Students calculate  $\Delta t$  using  $\Delta t = t_{final} - t_{initial}$  from the activity on the facing page.

Students differentiate, on a graph, between an instant and an interval of time.

**SUGGESTED LEARNING RESOURCES**



**GENERAL LEARNING OUTCOME CONNECTION**

*Students will...*

**Demonstrate appropriate scientific inquiry skills when seeking answers to questions (GLO C2)**

**SPECIFIC LEARNING OUTCOME**

**S3P-3-04:** Analyze the relationships among position, velocity, acceleration, and time for an object that is accelerating at a constant rate.

Include: transformations of position-time, velocity-time, and acceleration-time graphs using slopes and areas

**SKILLS AND ATTITUDES OUTCOMES**

S3P-0-2a: Select and use appropriate visual, numeric, graphical, and symbolic modes of representation to identify and represent relationships.

S3P-0-2d: Estimate and measure accurately, using Système International (SI) units.

**SUGGESTIONS FOR INSTRUCTION**

**Entry-Level Knowledge**

In Senior 2 Science, students were introduced to uniform motion (S2-3-01) and accelerated motion (S2-3-02 and S2-3-03). Senior 2 Science is intended to be a more qualitative treatment of motion developed within the context of the automobile. In Senior 3 Physics, the expectation is that a more sophisticated treatment of position, velocity, and acceleration will include a more complete graphical analysis with emphasis on the slope and area relationships, and an introduction to the mathematical relationships for motion.

**Notes to the Teacher**

The slope of a position-time graph represents velocity. The slope of a velocity-time graph represents acceleration. Alternatively, the area contained by an interval of time in a velocity-time graph represents the displacement during the time interval. The area contained under an interval of time in an acceleration-time graph represents change in velocity over the time interval. (See 3.14: Kinematics Graphs Transformation Organizer for a summary sheet.)

Begin this topic by interpreting the meaning of slope qualitatively, then by ratio. Given a graph of position versus time, an object moving faster will have a steeper slope. If

the graph is a straight line, then  $\Delta d \propto \Delta t$  and  $\Delta d = k\Delta t$ , where the constant  $k$  is the ratio of displacement to the time interval (the slope). Examination of the ratio leads to the conclusion that it is large when the object is moving fast and small when it is moving slow. The constant  $k$  represents the average velocity, and average velocity is defined as the rate of change of position with respect to time. In formula notation:

$$V_{avg} = \frac{\Delta d}{\Delta t}$$

The term “rate” refers to how much a quantity changes in one second. The quantity for a linear mechanical system is distance. Rate can be related to the equivalent for rotational (angle), fluid (volume or mass), electrical (charge), and thermal (heat) systems such that the concept of rate becomes intuitive. Fluid rates might include the output of an oil well in barrels per day. An example of electrical rate would be the amount of charge moving through the element of a toaster in C/s or amperes. Thermal rates, in joules per second or BTUs per second, can be used to describe the heating or cooling of our homes.



**SKILLS AND ATTITUDES OUTCOMES**

S3P-0-2e: Evaluate the relevance, reliability, and adequacy of data and data-collection methods.

Include: discrepancies in data and sources of error

S3P-0-2f: Record, organize, and display data, using an appropriate format.

Include: labelled diagrams, tables, graphs

S3P-0-2g: Interpret patterns and trends in data, and infer or calculate linear relationships among variables.

S3P-0-4a: Demonstrate work habits that ensure personal safety, the safety of others, and consideration of the environment.

**GENERAL LEARNING OUTCOME CONNECTION**

*Students will...*

**Understand how stability, motion, forces, and energy transfers and transformations play a role in a wide range of natural and constructed contexts (GLO D4)**

**SUGGESTIONS FOR INSTRUCTION**

Acceleration can be investigated graphically by referring to a straight-line graph of velocity versus time. From this graph,  $\Delta d \propto \Delta t$  and  $\Delta d = k\Delta t$ , where the constant  $k$  is the ratio of velocity change to the time interval. Examination of the ratio leads to the conclusion that it is large when the object's velocity is changing rapidly and small when it is changing slowly. The constant  $k$  (slope) represents the average acceleration of the object denoted by the symbol  $a$ . We can now define average acceleration as the rate of change of velocity with respect to time. In formula notation:

$$a_{avg} = \frac{\Delta v}{\Delta t}$$

Galileo struggled with the definition of acceleration as a rate of change of velocity with respect to time ( $\Delta v/\Delta t$ ) versus the rate of change of velocity with respect to position ( $\Delta v/\Delta d$ ). Ultimately, Galileo chose  $\Delta v/\Delta t$  because he was able to measure position and time, and establish this as a power relationship.

**SUGGESTIONS FOR ASSESSMENT**

**Observation**

Students take a pre/post test to examine knowledge of graphs and their relationships for position, displacement, velocity, and acceleration.

**Asking and Answering Questions Based on Data**

Graphical Analysis: Students assess for an understanding of graphical representations in the real world. Include graphical descriptions of motion.

Illustrative Example: Students describe the motion of an object, given a position-time graph.

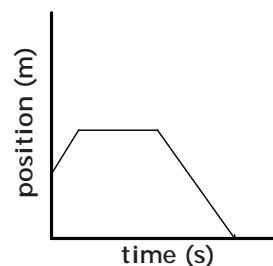

**GENERAL LEARNING OUTCOME CONNECTION**

*Students will...*

**Demonstrate appropriate scientific inquiry skills when seeking answers to questions (GLO C2)**

**SPECIFIC LEARNING OUTCOME**

**S3P-3-04:** Analyze the relationships among position, velocity, acceleration, and time for an object that is accelerating at a constant rate.

Include: transformations of position-time, velocity-time, and acceleration-time graphs using slopes and areas

**SKILLS AND ATTITUDES OUTCOMES**

S3P-0-2a: Select and use appropriate visual, numeric, graphical, and symbolic modes of representation to identify and represent relationships.

S3P-0-2d: Estimate and measure accurately, using Systeme International (SI) units.

**SUGGESTIONS FOR INSTRUCTION**

**Prior Knowledge Activities**

Research shows students are easily confused by the concepts of position and velocity, and velocity and acceleration. By investigating velocity change with respect to position as well as time, the student is forced to discriminate between the terms in the same exercise. The idea of negative acceleration is also often difficult to grasp. Students should work out all the possibilities for negative acceleration when the velocity changes are positive and when the velocity changes are negative. Review all combinations.

After introducing the relationships among position, velocity, acceleration, and time, have students apply these formulas to simple kinematics problems. Now is a good time for students to develop their skills for solving algebraic equations. Present several different types of problems to enhance these skills. See Appendix 3 for a complete list of problem types, solutions, and additional suggestions.

**Laboratory Activities**

Several types of activities may be used to study the relationships among position, velocity, acceleration, and time. Selection will depend on resources and the prior experience of the students.

Students complete a table of values for an object moving with a constant velocity of 5 m/s, and then plot the points onto a position time graph ( $t = 0, 1, 2, 3, 4, 5$ ). Repeat, using a velocity of 10 m/s, 2 m/s, and 0 m/s. Compare the slope of each line with the velocity the slope represents.

Repeat the above exercise for velocity and time, using various accelerations.

A student walks back and forth in a straight line, stopping now and then. Other members of the class record the position of the student at regular intervals of time. They gather this information, using metre sticks and a stopwatch, or by using a motion sensor, then construct position-time, velocity-time, and acceleration-time graphs.

Other types of motion that could be investigated include walking away from the group at a steady pace, stopping momentarily, walking towards the group at a faster pace, rolling a ball down an incline, throwing a ball in the air, running 100 m, or any other suitable event.

Students can also investigate these kinds of motion by using microcomputers and motion detectors, and analyzing the data by using graphical analysis software.



**SKILLS AND ATTITUDES OUTCOMES**

S3P-0-2e: Evaluate the relevance, reliability, and adequacy of data and data-collection methods.

Include: discrepancies in data and sources of error

S3P-0-2f: Record, organize, and display data, using an appropriate format.

Include: labelled diagrams, tables, graphs

S3P-0-2g: Interpret patterns and trends in data, and infer or calculate linear relationships among variables.

S3P-0-4a: Demonstrate work habits that ensure personal safety, the safety of others, and consideration of the environment.

**GENERAL LEARNING OUTCOME CONNECTION**

*Students will...*

**Understand how stability, motion, forces, and energy transfers and transformations play a role in a wide range of natural and constructed contexts (GLO D4)**

**SUGGESTIONS FOR INSTRUCTION**

A tickertape lab can be used to describe the motion of your hand or an object falling or accelerating in some other manner.

Students examine the motion of an object rolling across a table. Use a video camera to record the motion with a scale (ruler) behind the object. Play the tape, stopping and observing the equal displacements in equal time intervals. Fairly accurate data can be collected by placing a transparency onto the TV screen (static electricity will hold it in place) and plotting position with a marker. Many VCRs allow frame-by-frame viewing for this type of analysis. You may also want to calibrate your video camera with a stopwatch to determine the interval of time between successive frames.

**Demonstrations**

Use a rolling ball or cart with a number scale in the background. Relate the scale to the concepts of position, displacement, and intervals. A VCR with frame-by-frame advance can be used to stop the motion.

Students can bring samples of children's toys (either windup or electric) that will move at a constant speed (or very nearly constant).

**SUGGESTIONS FOR ASSESSMENT**

**Research Report/Presentation**

Students sketch a position-time graph of a real-world event (e.g., a runner, car, or rocket).

**Lab Report**

Students examine tickertape motion for position, velocity, and acceleration, taken from a lab activity.

**Journal Report**

Students collect samples of different types of motion from TV, movies, and cartoons. Students describe the motion and comment on the validity of the motion (e.g., the physics of the *Roadrunner* cartoons).

**Visual Displays**

Students describe the motion of a car from point A to point B, using position, velocity, and acceleration graphs.

**Graphical Analysis**

Students make measurements on a stroboscopic photograph, or sample tickertape, of a moving object.



**GENERAL LEARNING OUTCOME CONNECTION**

*Students will...*

**Demonstrate appropriate scientific inquiry skills when seeking answers to questions (GLO C2)**

**SPECIFIC LEARNING OUTCOME**

**S3P-3-04:** Analyze the relationships among position, velocity, acceleration, and time for an object that is accelerating at a constant rate.

Include: transformations of position-time, velocity-time, and acceleration-time graphs using slopes and areas

**SKILLS AND ATTITUDES OUTCOMES**

S3P-0-2a: Select and use appropriate visual, numeric, graphical, and symbolic modes of representation to identify and represent relationships.

S3P-0-2d: Estimate and measure accurately, using Système International (SI) units.

**SUGGESTIONS FOR INSTRUCTION**

Throw a ball into the air, roll a ball down an incline, up an incline, across a horizontal and up an incline, et cetera. Sketch a graph of velocity-time and acceleration for each case.

***Senior Years Science Teachers' Handbook Activities***

Students can complete a KWL/Knowledge chart (*Senior Years Science Teachers' Handbook*, page 9.13) to help assess their understanding of ideas from Senior 2 Science.

**Journal Entry**

Students construct a table of typical speeds for familiar moving objects (e.g., a baseball, car, or snail). Sketch two graphs of your trip to school: a position-time and velocity-time graph.

Students tell a story about motion (e.g., describe the motion of a car accelerating from rest at a stop sign to a constant speed). Include descriptions of the motion in the real world, including sample data, a graphic picture, and an algebraic representation.

Students make a list of objects that move at a constant speed (or very nearly constant).

Students identify other rates that they may know.

Students generate a list of objects that accelerate at a constant rate.



**SKILLS AND ATTITUDES OUTCOMES**

S3P-0-2e: Evaluate the relevance, reliability, and adequacy of data and data-collection methods.

Include: discrepancies in data and sources of error

S3P-0-2f: Record, organize, and display data, using an appropriate format.

Include: labelled diagrams, tables, graphs

S3P-0-2g: Interpret patterns and trends in data, and infer or calculate linear relationships among variables.

S3P-0-4a: Demonstrate work habits that ensure personal safety, the safety of others, and consideration of the environment.

**GENERAL LEARNING OUTCOME CONNECTION**

*Students will...*

**Understand how stability, motion, forces, and energy transfers and transformations play a role in a wide range of natural and constructed contexts (GLO D4)**

**SUGGESTIONS FOR INSTRUCTION**

**SUGGESTIONS FOR ASSESSMENT**

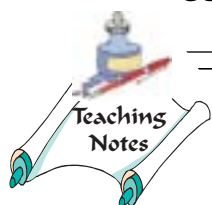

Blank area for teaching notes.

**SUGGESTED LEARNING RESOURCES**

**Journals**

Hestenes, David, and Malcolm Wells. (1992) "A Mechanics Baseline Test." *The Physics Teacher* 30.3: 159–166.

**Resources**

Appendix 3.1: Working with the Modes of Representation

Appendix 3.5: Analysis of Data using *Microsoft Excel*

Appendix 3.6: Describing Motion in Various Ways

Appendix 3.7: Introducing Motion: Position, Time, Distance and Speed, Displacement, and Velocity

Appendix 3.8: Motion: Interpreting Position-Time Graphs

Appendix 3.9: Journal Entry: Kinematics (Position and Velocity)

Appendix 3.10: Kinematics: Position, Velocity, and Acceleration Graphs

Appendix 3.11: Kinematics and Graphing Skills Builder

Appendix 3.14: Kinematics Graphs Transformation Organizer

**GENERAL LEARNING OUTCOME CONNECTION**

*Students will...*

**Demonstrate appropriate scientific inquiry skills when seeking answers to questions (GLO C2)**

**SPECIFIC LEARNING OUTCOME**

**S3P-3-05:** Compare and contrast average and instantaneous velocity for non-uniform motion.

Include: slopes of chords and tangents

**SUGGESTIONS FOR INSTRUCTION**

**Entry-Level Knowledge**

In Senior 2 Science, students are introduced to these ideas qualitatively.

**Notes to the Teacher**

A review of the graphical relationships for steady and accelerated motion is a good place to begin. Emphasis on the slope of a line as a rate of change facilitates a greater understanding of the meaning of velocity and acceleration. The meaning of an instant and an interval can lead into discussion to compare average and instantaneous velocity. The notion of a limit is difficult for students to understand. Consider the slope between two points on a curve as the points

become closer together, and relate this to the average and instantaneous velocities. As the interval decreases, the line approaches the tangent to the curve at that point.

Examine Diagram 5. To find average velocity, we need a time interval (i.e., two times). Plot a point on the curve at time 1 and another point at time 2. Connect the two points and find the slope of the line. This will give you the average velocity between the two positions. To find the velocity at a given time, plot a point on the curve at that time. Then, draw a tangent to the curve at that point (see Diagram 6). The slope of this tangent is the instantaneous velocity of the object at that given moment.

**Diagram 5**

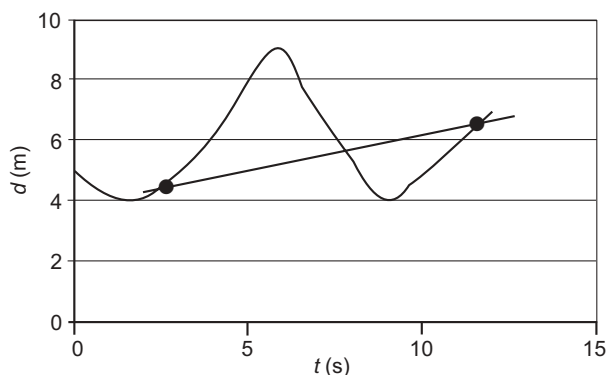

**Diagram 6**

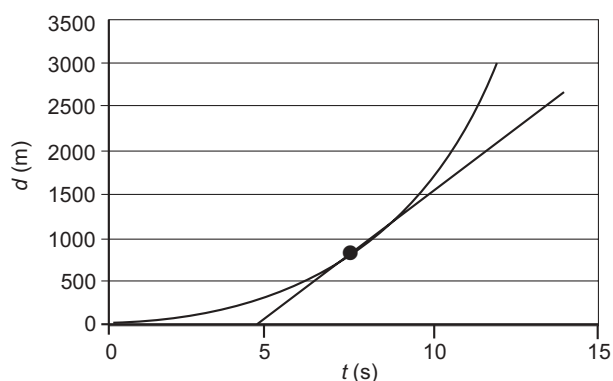



**SKILLS AND ATTITUDES OUTCOMES**

S3P-0-2a: Select and use appropriate visual, numeric, graphical, and symbolic modes of representation to identify and represent relationships.

S3P-0-2f: Record, organize, and display data, using an appropriate format.

Include: labelled diagrams, tables, graphs

S3P-0-2g: Interpret patterns and trends in data, and infer or calculate linear relationships among variables.

**GENERAL LEARNING OUTCOME CONNECTION**

*Students will...*

**Understand the composition of the Earth's atmosphere, hydrosphere, and lithosphere, as well as the processes involved within and among them (GLO D5)**

**SUGGESTIONS FOR INSTRUCTION**

**SUGGESTIONS FOR ASSESSMENT**

**Class Activity**

Videotape a ball falling under the influence of gravity. Play back the tape in slow motion or frame by frame and measure the position of the ball for equal intervals of time. The students can determine the average velocity of different time intervals by determining the distance the ball fell between two consecutive frames and knowing the time between two consecutive frames. The students can determine the instantaneous velocity of the ball by plotting a distance-versus-time graph, connecting the data points with a smooth curve, and finding the slope of the tangents to the curve at the desired times.

Students find velocity by graphical methods:

- a) Calculate average velocity
- b) Calculate instantaneous velocity

**SUGGESTED LEARNING RESOURCES**

Appendix 3.8: Motion: Interpreting Position-Time Graphs

Appendix 3.9: Journal Entry: Kinematics (Position and Velocity)



**GENERAL LEARNING OUTCOME CONNECTION**

Students will...

**Demonstrate appropriate scientific inquiry skills when seeking answers to questions (GLO C2)**

**SPECIFIC LEARNING OUTCOME**

**S3P-3-06:** Illustrate, using velocity-time graphs of uniformly accelerated motion, that average velocity can be represented as

$$\vec{V}_{avg} = \frac{\Delta \vec{d}}{\Delta t}$$

and that displacement can be calculated as

$$\Delta \vec{d} = \frac{\vec{v}_1 + \vec{v}_2}{2} \Delta t.$$

**SUGGESTIONS FOR INSTRUCTION**

**Notes to the Teacher**

For a given time interval such that an object begins with velocity  $v_1$  and accelerates uniformly to velocity  $v_2$ , the velocity-time graph will be a straight-line segment (Diagram 7). The midpoint of this segment will be  $(v_1 + v_2)/2$  (Diagram 8). The area under the trapezoid in Diagram 7 can be shown to be the same as the area under the rectangle created in Diagram 8.

To find the area of the trapezoid, one could draw a line at the midpoint between  $v_1$  and  $v_2$ . This creates two triangles of equal area

below and above the line. If we shift the upper triangle's area into the lower triangle, a rectangle has been created (see Diagram 8). Mathematically, the midpoint of the two velocities is the average of  $v_1$  and  $v_2$  and:

$$\Delta d = \text{area} = \text{height} \times \text{base} = \left( \frac{v_1 + v_2}{2} \right) \Delta t$$

$$\Delta d = \left( \frac{v_1 + v_2}{2} \right) \Delta t$$

(Recall that area under a velocity-time graph results in displacement.)

**Diagram 7**

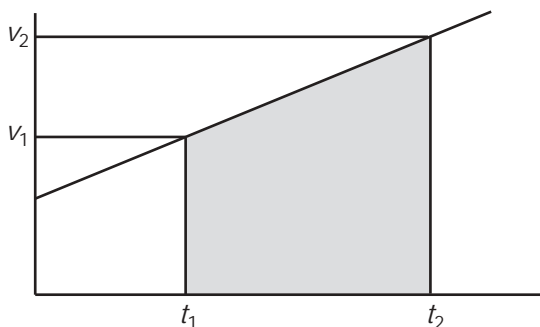

**Diagram 8**

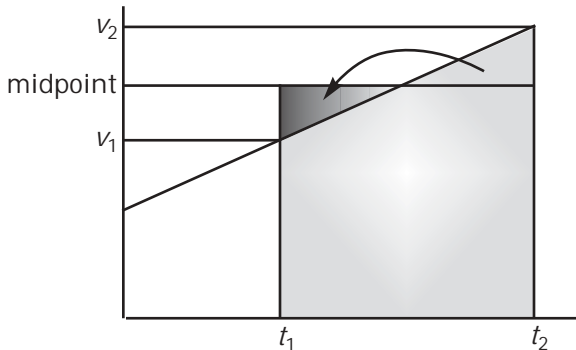

**GENERAL LEARNING OUTCOME CONNECTION**

*Students will...*

**Employ effective communication skills and utilize information technology to gather and share scientific and technological ideas and data  
(GLO C6)**

**SUGGESTIONS FOR INSTRUCTION**

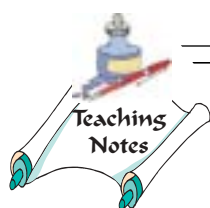

**SUGGESTIONS FOR ASSESSMENT**

**Asking and Answering Questions Based on Data**

Given an equation, students sketch the corresponding graph.

**SUGGESTED LEARNING RESOURCES**

Appendix 3.10: Kinematics: Position, Velocity, and Acceleration Graphs

Appendix 3.11: Kinematics and Graphing Skills Builder

Appendix 3.14: Kinematics Graphs Transformation Organizer



**GENERAL LEARNING OUTCOME CONNECTION**

Students will...

Demonstrate appropriate scientific inquiry skills when seeking answers to questions (GLO C2)

**SPECIFIC LEARNING OUTCOME**

**S3P-3-07:** Solve problems, using combined forms of:

$$\vec{V}_{avg} = \frac{\vec{v}_1 + \vec{v}_2}{2}, \quad \vec{V}_{avg} = \frac{\Delta \vec{d}}{\Delta t},$$

$$\vec{a}_{avg} = \frac{\Delta \vec{v}}{\Delta t}.$$

**SUGGESTIONS FOR INSTRUCTION**

**Notes to the Teacher**

Initially these formulas can be used to solve single-step problems to reinforce the representation for each variable, and to introduce students to the concept of solving problems algebraically. These formulas should then be applied to problems that require two and three steps to solve.

**Illustrative Example**

An object moving at 3 m/s accelerates for 4 s with uniform acceleration of 2 m/s<sup>2</sup>. Find the displacement moved.

*Solution:* State the given information in symbolic form:

$$v_1 = +3 \text{ m/s}$$

$$t = 4 \text{ s}$$

$$a = +2 \text{ m/s}^2$$

State the unknown:

$$\Delta d = ?$$

Enough information is given to find  $v_2$  using:

$$a = \frac{\Delta v}{\Delta t} = \frac{v_2 - v_1}{\Delta t}$$

$$a\Delta t = v_2 - v_1$$

Solving for  $v_2$ , we get:

$$v_2 = v_1 + a\Delta t$$

$$v_2 = +3 + +2(4) = +11 \text{ m/s}$$

Now, displacement can be found using:

$$\Delta d = \frac{(v_1 + v_2)}{2} \Delta t$$

$$\Delta d = \frac{(+11 + +3)}{2} \times 4$$

$$\Delta d = +28 \text{ m}$$

**Illustrative Example**

A car travelling at +10 m/s accelerates at a rate of +3.0 m/s<sup>2</sup> to a speed of +25 m/s. What distance does the car cover during the acceleration?

$$\Delta d = ?$$

$$v_1 = +10 \text{ m/s}$$

$$v_2 = +25 \text{ m/s}$$

$$a = +3.0 \text{ m/s}^2$$



**SKILLS AND ATTITUDES OUTCOMES**

S3P-0-2a: Select and use appropriate visual, numeric, graphical, and symbolic modes of representation to identify and represent relationships.

S3P-0-2g: Interpret patterns and trends in data, and infer or calculate linear relationships among variables.

**GENERAL LEARNING OUTCOME CONNECTION**

*Students will...*

**Understand how stability, motion, forces, and energy transfers and transformations play a role in a wide range of natural and constructed contexts (GLO D4)**

**SUGGESTIONS FOR INSTRUCTION**

Since any available version of a displacement formula requires time,  $\Delta t$  will have to be found first:

$$a = \frac{\Delta v}{\Delta t}$$

$$\Delta t = \frac{\Delta v}{a} = \frac{v_2 - v_1}{a}$$

$$\Delta t = \frac{+25 \text{ m/s} - +10 \text{ m/s}}{3.0 \text{ m/s}^2} = 5.0 \text{ s}$$

Now that  $\Delta t$ , has been found, we can find  $\Delta d$  as follows:

$$v_{avg} = \frac{\Delta d}{\Delta t}$$

$$\Delta d = \left( \frac{v_1 + v_2}{2} \right) \Delta t$$

$$\Delta d = \left( \frac{+10 \text{ m/s} + +25 \text{ m/s}}{2} \right) \times 5.0 \text{ s}$$

$$\Delta d = +87.5 \text{ m} = +88 \text{ m}$$

**SUGGESTIONS FOR ASSESSMENT**
**Performance Assessment**

**Student Assignments:** It is recommended that students be given a significant amount of practice in the problem-solving area. Many are not used to this level of mathematical treatment applied to physical situations.

**Written Assessment**

While calculation problems may be used, it is important to assess in all modes of representation (i.e., the visual, numeric, graphical, symbolic, and linguistic).

**SUGGESTED LEARNING RESOURCES**

See <[www.physicsweb.com](http://www.physicsweb.com)> for concept development problems for kinematics, including graphical analysis and problem solving.

Appendix 3.12: Kinematics: Position, Velocity, and Acceleration Graphs, and Their Equations

Appendix 3.13: Kinematics Sampler: Graphs, Equations, and Problem Solving



**GENERAL LEARNING OUTCOME CONNECTION**

*Students will...*

**Demonstrate appropriate scientific inquiry skills when seeking answers to questions (GLO C2)**

**SPECIFIC LEARNING OUTCOME**

**S3P-3-07:** Solve problems, using combined forms of:

$$\vec{V}_{avg} = \frac{\vec{v}_1 + \vec{v}_2}{2}, \quad \vec{V}_{avg} = \frac{\Delta \vec{d}}{\Delta t},$$

$$\vec{a}_{avg} = \frac{\Delta \vec{v}}{\Delta t}.$$

**SUGGESTIONS FOR INSTRUCTION**

**Illustrative Example**

If an object is accelerated at +5.0 m/s<sup>2</sup> and starts from rest, what is its velocity after it has travelled 20 m?

Solution: State the given information in symbolic form

$$\Delta d = +20.0 \text{ m} \quad v_1 = +0 \text{ m/s}$$

$$a = +5.0 \text{ m/s}^2 \quad v_2 = ?$$

No equation presented to date has enough information to provide a direct numerical answer in this scenario. Thus, two equations will have to be solved simultaneously. Algebraically, there are many ways to solve two equations simultaneously. Students should be challenged to reinforce the techniques they acquire in math class. A comparison method can be used as follows:

(Since  $\Delta t$  is not required for the final answer, set both equations equal to  $\Delta t$  to eliminate the time variable.)

Equation 1:

$$\Delta d = \left( \frac{v_1 + v_2}{2} \right) \Delta t$$

$$\Delta t = \left( \frac{2\Delta d}{v_1 + v_2} \right)$$

Equation 2:

$$a = \frac{\Delta v}{\Delta t}$$

$$\Delta t = \frac{\Delta v}{a}$$

$$\Delta t = \frac{v_2 - v_1}{a}$$

Since both equations are equal to  $\Delta t$ , they must be equal to each other.

$$\left( \frac{2\Delta d}{v_1 + v_2} \right) = \frac{v_2 - v_1}{a}$$

$$\left( \frac{2(20.0 \text{ m})}{0 + v_2} \right) = \frac{v_2 - 0}{5.0 \text{ m/s}^2}$$

$$\frac{40.0 \text{ m}}{v_2} = \frac{v_2}{5.0 \text{ m/s}^2}$$

$$v_2^2 = 200 \frac{\text{m}^2}{\text{s}^2}$$

$$v_2 = +14 \text{ m/s}$$

**Senior Years Science Teachers' Handbook Activities**

Students write Process Notes to aid their algebraic solutions.



**SKILLS AND ATTITUDES OUTCOMES**

S3P-0-2a: Select and use appropriate visual, numeric, graphical, and symbolic modes of representation to identify and represent relationships.

S3P-0-2g: Interpret patterns and trends in data, and infer or calculate linear relationships among variables.

**GENERAL LEARNING OUTCOME CONNECTION**

*Students will...*

**Understand how stability, motion, forces, and energy transfers and transformations play a role in a wide range of natural and constructed contexts (GLO D4)**

**SUGGESTIONS FOR INSTRUCTION**

**SUGGESTIONS FOR ASSESSMENT**

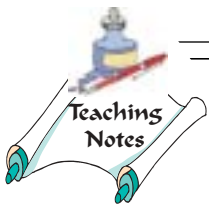

Large empty rectangular box for providing suggestions for instruction.

Large empty rectangular box for providing suggestions for assessment.

## NOTES





---

## **TOPIC 3.2: DYNAMICS**

The student will be able to:

S3P-3-08: Identify the four fundamental forces of nature.

S3P-3-09: Perform an experiment to demonstrate Newton's Second Law

$$(\vec{F}_{net} = ma).$$

S3P-3-10: Define the unit of force as the newton.

S3P-3-11: Define  $\vec{F}_{net}$  as the vector sum of all forces acting on a body.

Include: force of friction, normal force, gravitational force, applied forces

S3P-3-12: Construct free-body diagrams to determine the net force for objects in various situations.

Include: balanced and unbalanced forces, inclined planes

S3P-3-13: Solve problems, using Newton's Second Law and the kinematics equations from S3P-3-07.

Include: forces applied along a straight line and perpendicular forces

---

**GENERAL LEARNING OUTCOME CONNECTION**

*Students will...*

**Understand the composition of the universe, the interactions within it, and the impacts of humankind's continued attempts to understand and explore it (GLO D6)**

**SPECIFIC LEARNING OUTCOME**

**S3P-3-08:** Identify the four fundamental forces of nature.

---

**SUGGESTIONS FOR INSTRUCTION**

**Entry-Level Knowledge**

One of the primary goals in physics is to pursue an understanding of nature in terms of unifying principles. With respect to the unification of the fundamental forces, the greatest advances toward this goal include the unification of terrestrial and celestial mechanics by Newton; optics, electricity, and magnetism by James Clerk Maxwell; and space-time geometry with a theory of gravitation enunciated by Albert Einstein. The Standard Model of particle physics has achieved a unification of the Electromagnetic and Weak Nuclear Forces for very high energy levels. For an interesting description (and accompanying chart) of the nature of this model, consult the article by Steven Weinberg listed in the Suggested Learning Resources for this outcome.

The four fundamental forces in nature are the Strong Nuclear Force, the Weak Nuclear Force, the Gravitational Force, and the Electromagnetic Force.

- The **Strong Nuclear Force** is an attractive force that holds protons and neutrons in the nucleus of the atom. It is an extremely strong force necessary to overcome the repulsive force between two protons and only acts at short ranges of about  $10^{-15}$  m.
- The **Weak Nuclear Force** is a force exerted between all subatomic particles. It enables the conversion of one type of quark into another, and is responsible for some types of nuclear decay.
- The **Gravitational Force** is an attractive force that all objects exert on each other and is dependent on the objects' masses.
- The **Electromagnetic Force** is the force that charged particles exert on each other.

**Note:** The Electromagnetic Force is responsible for most of the named forces that will be seen in high school physics (e.g., the coulomb and magnetic forces, the normal force, the tension force, frictional forces, and even applied forces).



**SKILLS AND ATTITUDES OUTCOMES**

S3P-0-1c: Relate the historical development of scientific ideas and technology to the form and function of scientific knowledge today.

S3P-0-1e: Differentiate between how scientific theories explain natural phenomena and how scientific laws identify regularities and patterns in nature.

**GENERAL LEARNING OUTCOME CONNECTION**

*Students will...*

**Describe and appreciate the similarity and diversity of forms, functions, and patterns within the natural and constructed world (GLO E1)**

**SUGGESTIONS FOR INSTRUCTION**

**SUGGESTIONS FOR ASSESSMENT**

***Senior Years Science Teachers' Handbook Activities***

Students use a jigsaw activity. Expert groups are formed for each fundamental force. The experts research and complete Concept Frames to describe the force with examples. Then groups of four are formed (with an expert on each force) to exchange information.

**Observation**

Students use a Compare and Contrast Frame to distinguish among the various forces.

**SUGGESTED LEARNING RESOURCES**

Weinberg, Steven. (1999) "A Unified Physics by 2050?" *Scientific American*: 68-73.



**GENERAL LEARNING OUTCOME CONNECTION**

*Students will...*

**Demonstrate appropriate scientific inquiry skills when seeking answers to questions (GLO C2)**

**SPECIFIC LEARNING OUTCOMES**

**S3P-3-09:** Perform an experiment to demonstrate Newton's Second Law ( $\vec{F}_{net} = m\vec{a}$ ).

**S3P-3-10:** Define the unit of force as the newton.

**S3P-3-11:** Define  $\vec{F}_{net}$  as the vector sum of all forces acting on a body.

Include: force of friction, normal force, gravitational force, applied forces

**SUGGESTIONS FOR INSTRUCTION**

**Entry-Level Knowledge**

In Senior 2 Science, students investigated Newton's Second Law qualitatively in terms of the proportional relationships between force and acceleration and force and mass. In addition, students of Senior 2 Science were introduced to Newton's First and Third Laws.

**Newton's Three Laws:**

*Newton's First Law:* If no external or unbalanced force acts on an object, its state of rest or its constant speed are maintained.

*Newton's Second Law:*  $F_{net} = ma$ .

*Newton's Third Law:* For every action force, there exists a reaction force that is equal in magnitude but opposite in direction.

**Notes to the Teacher**

Typically, an experiment to demonstrate Newton's Second Law involves a set-up in which a known net force acts on a known mass. The acceleration may be measured with a motion probe, tickertape timer device, or video analysis. The forces may be measured with a force probe, spring scale, or a known gravitational force (weight). One possible set-up is shown below.

A lab cart ( $m_1$ ) on a horizontal surface is being pulled by a string that is connected to a falling mass through a pulley. If we increase the mass (force of gravity increases), we can measure acceleration and graph it. The force-versus-acceleration graph is a straight line and the slope is the ratio of force to acceleration. Ask students: Under what conditions will this ratio be large or small? It is large for objects that

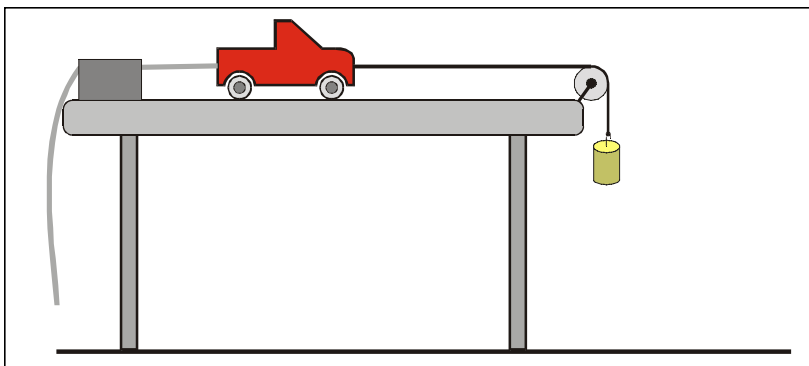

**SKILLS AND ATTITUDES OUTCOMES**

S3P-0-2h: Analyze problems, using vectors.  
 Include: adding and subtracting vectors in straight lines and at right angles, vector components

S3P-0-2b: Propose problems, state hypotheses, and plan, implement, adapt, or extend procedures to carry out an investigation where required.

SS3P-0-4b: Work cooperatively with a group to identify prior knowledge, initiate and exchange ideas, propose problems and their solutions, and carry out investigations.

S3P-0-4c: Demonstrate confidence in carrying out scientific investigations and in addressing STSE issues.

**GENERAL LEARNING OUTCOME CONNECTION**

*Students will...*

**Understand how stability, motion, forces, and energy transfers and transformations play a role in a wide range of natural and constructed contexts (GLO D4)**

**SUGGESTIONS FOR INSTRUCTION**

**SUGGESTIONS FOR ASSESSMENT**

are difficult to accelerate, and small for objects that are easy to accelerate. This resistance to acceleration is called the inertial mass of the object.

The relationship between  $F_{net}$  and acceleration can also be demonstrated in a lab, using dynamic carts on an inclined plane. As the angle of the incline increases, the force acting on the cart also increases according to  $\sin\theta$ .

$F = ma$  defines force. The SI units for force can be derived from this equation. Therefore, a unit of force is a  $\text{kg}\cdot\text{m}/\text{s}^2$ , and is given the name newton (N).

**Note:** The  $F$  in  $F = ma$  is the net force acting on the mass and should always be written as:

$F_{net} = ma$ , where  $F_{net}$  = sum of the applied forces.

OR

$\Sigma \vec{F} = ma$ , where  $\Sigma \vec{F}$  = sum of the applied forces.

Students submit a lab report that states the relationship among force, mass, and acceleration, and some systemic errors (specific to this lab) that could be redesigned to improve future trials.

**SUGGESTED LEARNING RESOURCES**

- Appendix 3.15: Journal Entry: Dynamics and Diagrams
- Appendix 3.16: Free-Body Diagrams: Linear Motion
- Appendix 3.17: Free-Body Diagrams 2: Linear Motion



**GENERAL LEARNING OUTCOME CONNECTION**

*Students will...*

**Demonstrate appropriate scientific inquiry skills when seeking answers to questions (GLO C2)**

**SPECIFIC LEARNING OUTCOMES**

**S3P-3-09:** Perform an experiment to demonstrate Newton's Second Law ( $\vec{F}_{net} = m\vec{a}$ ).

**S3P-3-10:** Define the unit of force as the newton.

**S3P-3-11:** Define  $\vec{F}_{net}$  as the vector sum of all forces acting on a body.

Include: force of friction, normal force, gravitational force, applied forces

**SUGGESTIONS FOR INSTRUCTION**

The notion of a net force in the Second Law should be clearly stated as  $\vec{F}_{net} = \vec{F}_{applied} + \vec{F}_{friction}$ . The applied force is the vector sum of all forces acting on the mass in the direction of motion. Many textbooks gloss over this idea. In Senior 3 Physics, students should address problems using multiple forces under the following conditions:

- a) forces acting on the same line (a single applied force and the force of friction);
- b) forces acting at right angles to each other; and
- c) as a component.

**Journal Entry:** Students describe various conditions that may result in zero acceleration.

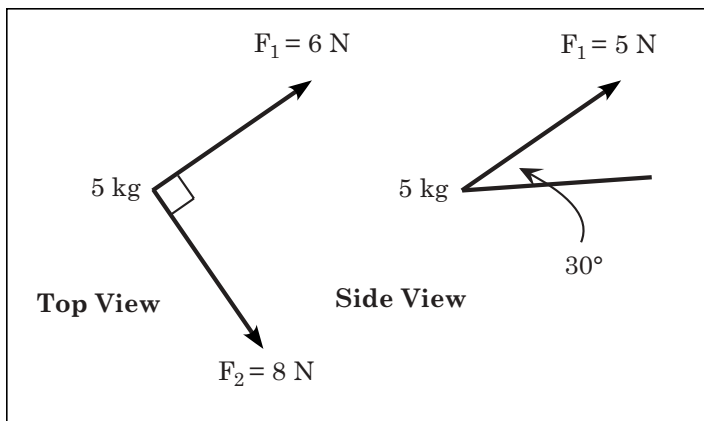

**SKILLS AND ATTITUDES OUTCOMES**

S3P-0-2h: Analyze problems, using vectors.  
 Include: adding and subtracting vectors in straight lines and at right angles, vector components

S3P-0-2b: Propose problems, state hypotheses, and plan, implement, adapt, or extend procedures to carry out an investigation where required.

SS3P-0-4b: Work cooperatively with a group to identify prior knowledge, initiate and exchange ideas, propose problems and their solutions, and carry out investigations.

S3P-0-4c: Demonstrate confidence in carrying out scientific investigations and in addressing STSE issues.

**GENERAL LEARNING OUTCOME CONNECTION**

*Students will...*

**Understand how stability, motion, forces, and energy transfers and transformations play a role in a wide range of natural and constructed contexts (GLO D4)**

**SUGGESTIONS FOR INSTRUCTION**

**SUGGESTIONS FOR ASSESSMENT**

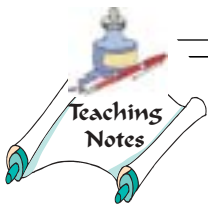

**GENERAL LEARNING OUTCOME CONNECTION**

*Students will...*

**Demonstrate appropriate scientific inquiry skills when seeking answers to questions (GLO C2)**

**SPECIFIC LEARNING OUTCOME**

**S3P-3-12:** Construct free-body diagrams to determine the net force for objects in various situations.

Include: balanced and unbalanced forces, inclined planes

---

**SUGGESTIONS FOR INSTRUCTION**

**Entry-Level Knowledge**

Mass and weight are discussed qualitatively in Grade 8 Science as being distinct.

Several references on FBDs are included in the Suggested Learning Resources for this outcome.

**Notes to the Teacher**

Introduce free-body diagrams (FBDs) here to illustrate that there can be multiple forces acting on an object even if it appears that there is only one force. The forces will all add together to a resultant force that is called *net force*. FBDs are vector diagrams of the forces acting on an object. Students should consider gravitational, normal, frictional, and applied forces as they practise drawing FBDs.

In a free-body diagram, the gravitational force ( $F_g$ ) points downward. The normal force is always perpendicular to the surface with which a body is in contact and it stops objects from falling through the surface. For a body on an inclined plane, the normal force is perpendicular to the slope. The frictional force is always parallel to the surface of contact and usually opposes the motion of the object. Applied forces are any push or pull on the object. Applied forces through a string or rope are called tension forces and are directed along the string such that the force pulls equally on either end of the string.





**SKILLS AND ATTITUDES OUTCOME**

S3P-0-2h: Analyze problems, using vectors.

Include: adding and subtracting vectors in straight lines and at right angles, vector components

**GENERAL LEARNING OUTCOME CONNECTION**

*Students will...*

**Employ effective communication skills and utilize information technology to gather and share scientific and technological ideas and data (GLO C6)**

**SUGGESTIONS FOR INSTRUCTION**

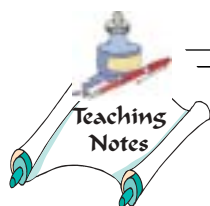

A large empty rectangular box intended for teaching notes, located under the 'SUGGESTIONS FOR INSTRUCTION' header.

**SUGGESTIONS FOR ASSESSMENT**

Given an object (on a table, et cetera), students complete a free-body diagram according to a defined set of criteria.

**SUGGESTED LEARNING RESOURCES**

Court, J. (1993) "Free Body Diagrams." *The Physics Teacher* 31.2: 104.

Court, J. (1999) "Free Body Diagrams" *The Physics Teacher* 37.7: 427.

Fisher, K. (1999) "Exercise in Drawing and Utilizing Free-Body Diagrams." *The Physics Teacher* 37.7: 434.

Appendix 3.16: Free-Body Diagrams: Linear Motion

Appendix 3.17: Free-Body Diagrams 2: Linear Motion

**GENERAL LEARNING OUTCOME CONNECTION**

*Students will...*

**Demonstrate appropriate scientific inquiry skills when seeking answers to questions (GLO C2)**

**SPECIFIC LEARNING OUTCOME**

**S3P-3-13:** Solve problems, using Newton's Second Law and the kinematics equations from S3P-3-07.

Include: forces applied along a straight line and perpendicular forces

---

**SUGGESTIONS FOR INSTRUCTION**

**Notes to the Teacher**

Many different kinds of motion can be used to illustrate Newton's Second Law, including:

- Biomechanics of human motion (muscles pulling on bones)
- Sports (downhill skiing, skateboarding)
- Pulleys
- Carts

Students address the following types of problems:

- Single and multiple forces acting on a straight line
- Two perpendicular forces acting on an object
- Single force acting at an angle on an object (resolved using components)

***Senior Years Science Teachers' Handbook Activities***

Students use process notes to aid their algebraic solutions.



**SKILLS AND ATTITUDES OUTCOME**

S3P-0-2h: Analyze problems, using vectors.

Include: adding and subtracting vectors in straight lines and at right angles, vector components

**GENERAL LEARNING OUTCOME CONNECTION**

*Students will...*

**Understand how stability, motion, forces, and energy transfers and transformations play a role in a wide range of natural and constructed contexts (GLO C6)**

**SUGGESTIONS FOR INSTRUCTION**

**SUGGESTIONS FOR ASSESSMENT**

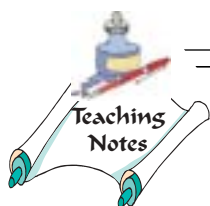

A large empty rectangular box for providing suggestions for instruction.

**Problem Construction**

Students construct their own dynamics problems (including a solution).

**SUGGESTED LEARNING RESOURCES**

Court, J. (1993) "Free Body Diagrams." *The Physics Teacher* 31.2: 104.

Court, J. (1999) "Free Body Diagrams." *The Physics Teacher* 37.7: 427.

Fisher, K. (1999) "Exercise in Drawing and Utilizing Free-Body Diagrams." *The Physics Teacher* 37.7: 434.



## NOTES



---

## ***TOPIC 4: FIELDS***

- 4.1: Gravitational Fields
  - 4.2: Electric Fields
  - 4.3: Magnetic Fields
  - 4.4: Electromagnetism
-

## TOPIC 4: FIELDS

The gravitational, electric, and magnetic forces are most often introduced separately from each other, thus limiting students' opportunities to compare and contrast these fundamental forces of nature.

*"The idea of action at a distance was difficult for early scientists to understand, the fact that an inanimate object could exert a force at a place where it was not located was quite disturbing and considerable effort was expended on theories of intermediary actions and ethers. The acceptance of Newton's theories established the idea of force as an action at a distance as a "habit of thought." (Arons, 1982)*

In this topic, each field is approached in a similar manner. The field extends throughout space and is detected by placing a mass, charge, or magnet (a current element) at some point in the field. Each field is described as a unit force (i.e., a force per unit "something" where the "something" is a mass, charge, or current element). Each field name,  $\mathbf{g}$ ,  $\mathbf{E}$ , and  $\mathbf{B}$ , is a name for the concept on the right side of the equal sign.

$$\bar{g} = \frac{\bar{F}}{m} \quad \bar{E} = \frac{\bar{F}}{q} \quad \bar{B} = \frac{\bar{F}}{Il}$$

An examination of the units illustrates the consistent approach to finding each force in newtons. The force of gravity (called the weight) is found by taking the field in N/kg and multiplying by the number of kilograms of mass in the field ( $F_g = mg$ ). Similarly, the electric force is found by taking the field in N/C and multiplying by the number of coulombs of charge in the field ( $F = qE$ ); the magnetic force is found by taking the field in N/A-m and multiplying by the number of A.m in the field ( $F = BIl$ ).

Thus,

$$\bar{F}_g = m\bar{g} \quad \bar{F}_e = q\bar{E} \quad \bar{F}_B = \bar{B}Il$$

### Topics

- 4.1: Gravitational Fields
- 4.2: Electric Fields
- 4.3: Magnetic Fields
- 4.4: Electromagnetism



## NOTES



---

## **TOPIC 4.1: GRAVITATIONAL FIELDS**

Students define the gravitational force constant  $g$  as a force per unit mass in N/kg, and the weight as  $F_g = mg$ . The acceleration due to gravity (i.e.,  $a_g = g$ ) is derived from Newton's laws and determined in the laboratory. Students describe the normal force in terms of the mutual attraction of masses, and draw simple free-body diagrams.

The student will be able to:

- S3P-4-01: Define the gravitational field qualitatively as the region of space around a mass where another point mass experiences a force.
  - S3P-4-02: Diagram the Earth's gravitational field, using lines of force.
  - S3P-4-03: Define the gravitational field quantitatively as a force per unit mass.
  - S3P-4-04: Compare and contrast the terms "mass" and "weight."
  - S3P-4-05: Describe, qualitatively and quantitatively, apparent weight changes in vertically accelerating systems.  
*Examples: elevators, spacecraft...*
  - S3P-4-06: Derive the acceleration due to gravity from free fall and Newton's laws.
  - S3P-4-07: Perform an experiment to calculate  $g$  near the surface of the Earth.
  - S3P-4-08: Solve free-fall problems.
  - S3P-4-09: Describe terminal velocity, qualitatively and quantitatively.
  - S3P-4-10: Define the coefficient of friction ( $\mu$ ) as the ratio of the force of friction and the normal force.
  - S3P-4-11: Distinguish between static and kinetic friction.
  - S3P-4-12: Compare the effects of the normal force, materials involved, surface area, and speed on the force of friction.
  - S3P-4-13: Solve problems with the coefficient of friction for objects on a horizontal surface.
-



**GENERAL LEARNING OUTCOME CONNECTION**

*Students will...*

**Understand how stability, motion, forces, and energy transfers and transformations play a role in a wide range of natural and constructed contexts (GLO D4)**

**SPECIFIC LEARNING OUTCOMES**

**S3P-4-01:** Define the gravitational field qualitatively as the region of space around a mass where another point mass experiences a force.

**S3P-4-02:** Diagram the Earth's gravitational field using lines of force.

**SUGGESTIONS FOR INSTRUCTION**

**Notes to the Teacher**

Discuss with students the universal nature of the attraction between any two masses. Extend the discussion to the case of the Earth's gravitational field. Michael Faraday introduced the concept of "field lines" to represent the strength and direction of the force. More field lines per unit area represent a stronger field. This occurs in regions where the lines are closer together. The direction of the field is the direction the force would act on a "test mass" brought into the field. A "test mass" simply means "as if we put a mass of 1 kg in the field."

**Note:** The gravitational field is continuous and the field lines just provide a visual representation of the field.

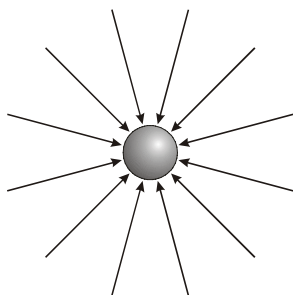

The diagram indicates that the field lines get further apart as the gravitational field strength gets weaker.

**Teacher Demonstration**

Demonstrate the field of the Earth with a mass and spring scale (calibrated in newtons).

***Senior Years Science Teachers' Handbook Activities***

Students use a Concept Frame and Concept Overview (see *Senior Years Science Teachers' Handbook*, Attachments 11.2 and 11.3) to develop the concepts of the gravitational field and its associated field lines.

Use a Listen-Draw-Pair-Share sheet for an introduction to the gravitational field concept (see *Success for All Learners: A Handbook on Differentiating Instruction*, Attachment 5, and *Senior Years Science Teachers' Handbook*, Building a Scientific Vocabulary, Developing Scientific Concepts Using Graphic Displays, Attachments 10.2, 11.2, and 11.3).



**SKILLS AND ATTITUDES OUTCOMES**

S3P-0-1c: Relate the historical development of scientific ideas and technology to the form and function of scientific knowledge today.

S3P-0-2a: Select and use appropriate visual, numeric, graphical, and symbolic modes of representation to identify and represent relationships.

**GENERAL LEARNING OUTCOME CONNECTION**

*Students will...*

**Understand the composition of the Earth's atmosphere, hydrosphere, and lithosphere, as well as the processes involved within and among them (GLO D5)**

**SUGGESTIONS FOR INSTRUCTION**

**SUGGESTIONS FOR ASSESSMENT**

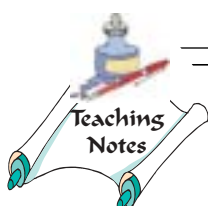

A large empty rectangular box for providing suggestions for instruction.

**Visual Display**

Students explain, with the aid of diagrams, the gravitational field of the Earth.

**Self-Assessment**

Use a vocabulary strategy with students (e.g., Three-Point Approach) to demonstrate their qualitative and quantitative understanding of the term "gravitational field." (See *Senior Years Science Teachers' Handbook*, Building a Scientific Vocabulary, page 10.1.)

**SUGGESTED LEARNING RESOURCES**

Appendix 4.2: Journal Entry: Gravitational Fields



**GENERAL LEARNING OUTCOME CONNECTION**

*Students will...*

**Understand how stability, motion, forces, and energy transfers and transformations play a role in a wide range of natural and constructed contexts (GLO D4)**

**SPECIFIC LEARNING OUTCOMES**

**S3P-4-03:** Define gravitational field quantitatively as a force per unit mass.

**S3P-4-04:** Compare and contrast the terms “mass” and “weight.”

**SKILLS AND ATTITUDES OUTCOMES**

S3P-0-1c: Formulate operational definitions of major variables or concepts.

S3P-0-2a: Select and use appropriate visual, numeric, graphical, and symbolic modes of representation to identify and represent relationships.

**SUGGESTIONS FOR INSTRUCTION**

**Notes to the Teacher**

The gravitational field strength is defined as the gravitational force that a “test mass” would experience at some point in the field.

That is,  $g = \frac{F_g}{m}$ . The units of **g** are  $\frac{N}{kg}$ .

Near the surface of the Earth, **g** is 9.8 N/kg directed towards the centre of the Earth.

Students should understand that every kilogram of mass near the Earth experiences 9.8 newtons of force. Students should also recognize that to define **g** operationally, we can measure force, using a spring scale, and mass, using a balance.

**Student Activities**

Students solve for various problem situations, using  $F_g = mg$ . See Appendix 4.1: Vertical Motion at the Earth’s Surface.

**Teacher Demonstration**

Discuss or demonstrate (by changing the faceplate of a spring scale) what a spring scale would read on the surface of various celestial bodies (Moon, planets, Sun, et cetera).

**Senior Years Science Teachers’ Handbook Activities**

Students use a vocabulary strategy (e.g., Three-Point Approach) to demonstrate their quantitative understanding of the term “gravitational field.” (See *Senior Years Science Teachers’ Handbook*, Building a Scientific Vocabulary.)

Students compare and contrast mass and weight, using the *Senior Years Science Teachers’ Handbook* Compare and Contrast Frame.

Students research the **g** value for various locations (e.g., Winnipeg), using the Internet (National Research Council). Provide examples of different values of **g** on Earth (equator versus poles; Winnipeg versus Mount Everest) and different values of **g** for celestial bodies (planets/moons, stars).

**Interpretation of Media Reports**

Discuss the effects on the human body when exposed to lower/higher **g** environments for an extended period of time (e.g., International Space Station astronauts).



**SKILLS AND ATTITUDES OUTCOMES**

S3P-0-2f: Record, organize, and display data, using an appropriate format.

Include: labelled diagrams, tables, graphs

S3P-0-3b: Describe examples of how technology has evolved in response to scientific advances, and how scientific knowledge has evolved as the result of new innovations in technology.

**GENERAL LEARNING OUTCOME CONNECTION**

*Students will...*

**Understand how stability, motion, forces, and energy transfers and transformations play a role in a wide range of natural and constructed contexts (GLO D4)**

**SUGGESTIONS FOR INSTRUCTION**

**SUGGESTIONS FOR ASSESSMENT**

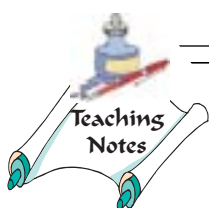

A large empty rectangular box for providing suggestions for instruction.

Students prepare a lab report using Laboratory Report Outline, Attachment 11.4, *Senior Years Science Teachers' Handbook*.

Students use a Concept Frame and Concept Overview, Attachments 11.2 and 11.3, *Senior Years Science Teachers' Handbook*.

Students solve problems for any variable in  $F_g = mg$ , given the other two. Assume that frictional effects are negligible.

**SUGGESTED LEARNING RESOURCES**

**References**

Iona, M. (April 1999) "Weight—An Official Definition." *The Physics Teacher* 37:4: 238.

*Senior Years Science Teachers' Handbook*, Writing to Learn Science, Technical Writing in Science, and Building a Scientific Vocabulary (Manitoba Education and Training, 1997)

Appendix 4.1: Vertical Motion at the Earth's Surface

Appendix 4.2: Journal Entry: Gravitational Fields



**GENERAL LEARNING OUTCOME CONNECTION**

Students will...

Understand how stability, motion, forces, and energy transfers and transformations play a role in a wide range of natural and constructed contexts (GLO D4)

**SPECIFIC LEARNING OUTCOME**

**S3P-4-05:** Describe, qualitatively and quantitatively, apparent weight changes in vertically accelerating systems.

Examples: elevators, spacecraft...

**SUGGESTIONS FOR INSTRUCTION**

**Notes to the Teacher**

Draw free-body diagrams of an object in a moving system (elevator) under different conditions (i.e., constant velocity, acceleration upward, or acceleration downward).

Solve problems for apparent weight in a moving system (elevator) under different conditions (i.e., constant velocity, acceleration upward, or acceleration downward).

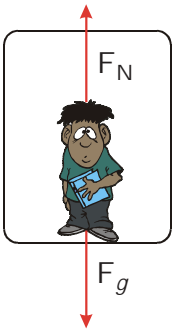
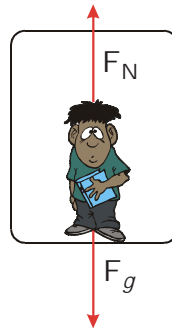
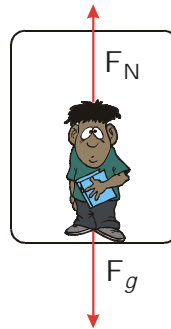
		
<p><b>Diagram A</b> constant velocity (<math>a = 0 \text{ m/s}^2</math>) <math>F_{\text{net}} = ma</math> <math>F_N + F_g = 0</math> <math>F_N = -F_g</math> <math> F_N  =  F_g </math></p>	<p><b>Diagram B</b> accelerated motion upward (<math>a &gt; 0</math>) <math>F_{\text{net}} = ma</math> <math>F_N + F_g = (+)</math> <math>F_N = (+) + (-F_g)</math> <math>= (+) + (+)</math> <math>\therefore  F_N  &gt;  F_g </math></p> <p>Note that this applies to elevator accelerating while going up or slowing while going down.</p>	<p><b>Diagram C</b> accelerated motion downward (<math>a &lt; 0</math>) <math>F_{\text{net}} = ma</math> <math>F_N + F_g = (-)</math> <math>F_N = (-) + (-F_g)</math> <math>= (-) + (+)</math> <math>\therefore  F_N  &lt;  F_g </math></p> <p>Note that this applies to elevator slowing while going up or accelerating while going down.</p>

$F_{\text{net}} = F_g + F_N$ , where  $F_N$  is the apparent weight of the object, sometimes referred to as  $F_{\text{SCALE}}$ .

**Student Activities**

Students videotape apparent weight changes in an accelerating elevator or examine various amusement park physics demonstrations involving vertical accelerations (e.g., rollercoaster).

**Senior Years Science Teachers' Handbook Activities**

Students research and report on various micro-gravity environments and their effects on the human body.



**SKILLS AND ATTITUDES OUTCOMES**

S3P-0-2a: Select and use appropriate visual, numeric, graphical, and symbolic modes of representation to identify and represent relationships.

S3P-0-2b: Propose problems, state hypotheses, and plan, implement, adapt, or extend procedures to carry out an investigation where required.

**GENERAL LEARNING OUTCOME CONNECTION**

*Students will...*

**Describe and appreciate how the natural and constructed world is made up of systems and how interactions take place within and among these systems (GLO E2)**

**SUGGESTIONS FOR INSTRUCTION**

**SUGGESTIONS FOR ASSESSMENT**

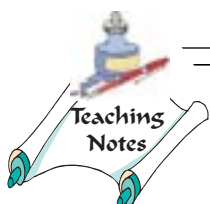

A large empty rectangular box for writing suggestions for instruction.

**Visual Displays**

Students explore directly (by visiting), or through a simulation, the physics of an amusement park ride. Complete a poster, diagram, or model that outlines forces relationships, and apparent weight changes.

**Answering Questions Based on Data**

Students calculate apparent weight under different conditions.

**SUGGESTED LEARNING RESOURCES**

Jensen, L. (1986) "Apparent Weight Changes in an Elevator." *A Potpourri of Physics Teaching Ideas*: 89.

Evans, L. and J. Stevens. (1978) "Which Way Is Up?" *The Physics Teacher* 16:8: 561.

**Multimedia**

*Physics at Work*: Side A/B, Frames 491, acceleration; 494, skydivers; 511, free fall; 393-94, 605, 613-17, 639-40, 648-51.

*Physics of Flight*: Frames 37277..., Viscous Flow; 27115..., 30642..., Aerodynamic Lift; 41399..., Motion of free-fall parachutist; 1155-59

*Interactive Physics Simulations*



**GENERAL LEARNING OUTCOME CONNECTION**

*Students will...*

**Demonstrate appropriate scientific inquiry skills when seeking answers to questions (GLO C2)**

**SPECIFIC LEARNING OUTCOMES**

**S3P-4-06:** Derive the acceleration due to gravity from free fall and Newton's laws.

**S3P-4-07:** Perform an experiment to calculate  $g$  near the surface of the Earth.

**SKILLS AND ATTITUDES OUTCOMES**

S3P-0-2a: Select and use appropriate visual, numeric, graphical, and symbolic modes of representation to identify and represent relationships.

**SUGGESTIONS FOR INSTRUCTION**

**Notes to the Teacher**

Show the derivation for acceleration due to gravity:

For free fall:

$$F_{\text{net}} = ma \text{ where}$$

$$F_{\text{net}} = F_{\text{applied}} + F_{\text{friction}}$$

$$F_{\text{applied}} = F_g \text{ and } F_{\text{friction}} = 0$$

(assuming no air resistance)

$$F_{\text{net}} = F_g$$

$$ma = mg$$

$$a = g$$

There are several ways to calculate  $g$  experimentally. Examples of these include:

- Perform a tickertape experiment, using a free-falling mass, and plot d-t, v-t, and a-t graphs.
- Conduct microcomputer-based experiments to determine  $g$ :
- Use spring scales (calibrated in newtons) and masses to determine  $g$  by plotting the gravitational force (spring scale reading) versus mass on a graph. The slope of the graph determines the value of  $g$ .

**Student Activities**

Students solve problems, using kinematic equations from learning outcome S3P-1-07 and  $F_g = mg$ .

Students interpret free-fall motion from videos, using graphs produced with *Videograph* software.

Students perform free-fall simulations, using *Interactive Physics Simulations* software.

**Multimedia Simulations**

Software: *Interactive Physics Simulations*, Activities #3: Free Fall; #6: Grape Drop

Physics with Computers (Vernier)—Experiment #5: Picket Fence Free Fall

Physics with Computers (Vernier)—Experiment #6: Ball Toss



**SKILLS AND ATTITUDES OUTCOMES**

S3P-0-2d: Estimate and measure accurately, using Système International (SI) units.

S3P-0-2e: Evaluate the relevance, reliability, and adequacy of data and data-collection methods.

Include: discrepancies in data and sources of error

S3P-0-2g: Interpret patterns and trends in data, and infer or calculate linear relationships among variables.

**GENERAL LEARNING OUTCOME CONNECTION**

*Students will...*

**Understand the composition of the universe, the interactions within it, and the impacts of humankind's continued attempts to understand and explore it (GLO D6)**

**SUGGESTIONS FOR INSTRUCTION**

**SUGGESTIONS FOR ASSESSMENT**

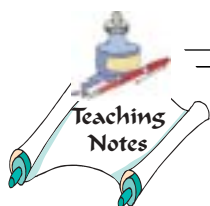

Blank area for teaching notes.

Students solve free-fall problems limited to vertical motion only using kinematic equations and  $F_g = mg$ . See Appendix 4.1: Vertical Motion at the Earth's Surface.

**SUGGESTED LEARNING RESOURCES**

**Journals**

Court, J. (1993) "Free Body Diagrams." *The Physics Teacher* 31:2: 104.

Court, J. (1999) "Free Body Diagrams." *The Physics Teacher* 37:7: 427.

Fisher, K. (1999) "Exercise in Drawing and Utilizing Free-Body Diagrams." *The Physics Teacher* 37.7: 434.

Evans, L. and J. Stevens. (1978) "Which Way Is Up?" *The Physics Teacher* 16.8: 561.

**Software**

*Interactive Physics Simulations*, Activities #3: Free Fall; #6: Grape Drop

Physics with Computers (Vernier)—Experiment #4: Determining  $g$  on an Incline.





**GENERAL LEARNING OUTCOME CONNECTION**

Students will...

Work cooperatively and value the ideas and contributions of others while carrying out scientific and technological activities (GLO C7)

**SPECIFIC LEARNING OUTCOME**

**S3P-4-08:** Solve free-fall problems.

**SKILLS AND ATTITUDES OUTCOMES**

S3P-0-2a: Select and use appropriate visual, numeric, graphical, and symbolic modes of representation to identify and represent relationships.

**SUGGESTIONS FOR INSTRUCTION**

**Notes to the Teacher**

In free fall, air resistance varies with the square of the speed (generally,  $F_{\text{air}} \propto v^2$ ). Therefore, as speed increases, air resistance also increases. In terms of the force vectors, the progression from a free-falling object as it achieves terminal velocity can be diagrammed as follows:

Students solve free-fall problems using the kinematics relations from outcome S3P-3-07. It should be noted that even though the motion is accelerated and the velocity changes, the average velocity is still a useful concept in solving these types of problems. It is also useful for students to sketch and compare graphical solutions to the algebraic relationships.

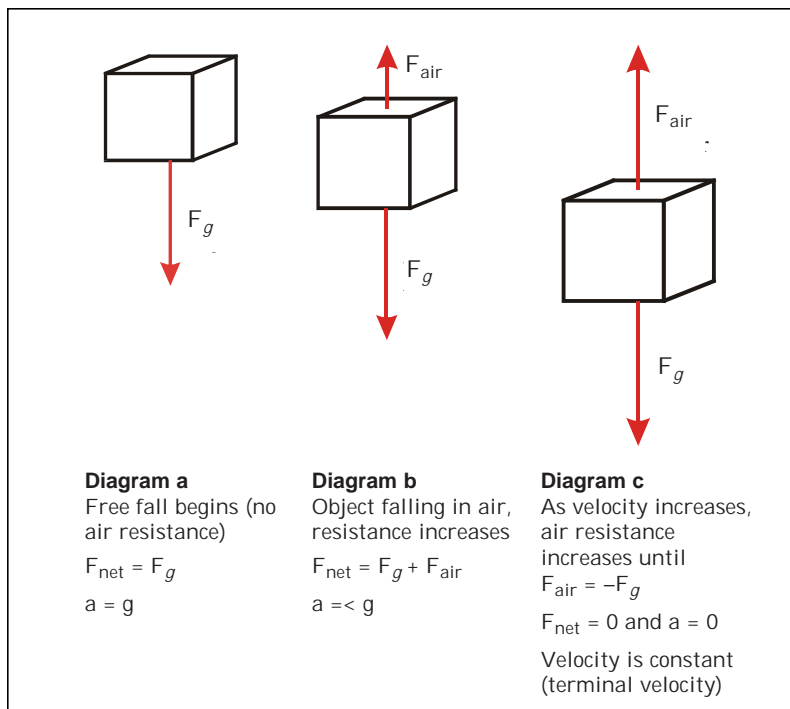

**SKILLS AND ATTITUDES OUTCOMES**

S3P-0-2d: Estimate and measure accurately, using Système International (SI) units.

S3P-0-2e: Evaluate the relevance, reliability, and adequacy of data and data-collection methods.

Include: discrepancies in data and sources of error

S3P-0-2g: Interpret patterns and trends in data, and infer or calculate linear relationships among variables.

**GENERAL LEARNING OUTCOME CONNECTION**

*Students will...*

**Evaluate, from a scientific perspective, information and ideas encountered during investigations and in daily life (GLO C8)**

**SUGGESTIONS FOR INSTRUCTION**

**SUGGESTIONS FOR ASSESSMENT**

**Teacher Demonstration**

Demonstrate and describe terminal velocity (e.g., compare dropping flat paper versus crumpled paper).

**Student Activities**

Students interpret free-fall motion from videos, using graphs produced with software.

Students perform free-fall simulations using *Interactive Physics Simulation* software.

Students solve free-fall problems limited to vertical motion only, using kinematic equations and  $F_g = mg$ .

Students compare free-falling objects and terminal velocity of objects, using a Compare and Contrast Frame from page 10.24 of the *Senior Years Science Teachers' Handbook*.

**SUGGESTED LEARNING RESOURCES**

**Software**

*Interactive Physics*, Activities #3: Free Fall; #6: Grape Drop

**Multimedia**

Videodiscs: *Physics at Work*: penny and feather

*Video Encyclopedia of Physics*

*Demonstrations*: penny and feather

*Physics of Flight*: Motion of free-fall parachutist



**GENERAL LEARNING OUTCOME CONNECTION**

*Students will...*

**Demonstrate appropriate scientific inquiry skills when seeking answers to questions (GLO C2)**

**SPECIFIC LEARNING OUTCOMES**

**S3P-4-09:** Describe terminal velocity, qualitatively and quantitatively.

**S3P-4-10:** Define the coefficient of friction ( $\mu$ ) as the ratio of the force of friction and the normal force.

**S3P-4-11:** Distinguish between static and kinetic friction.

**S3P-4-12:** Compare the effects of the normal force, materials involved, surface area, and speed on the force of friction.

**S3P-4-13:** Solve problems with the coefficient of friction for objects on a horizontal surface.

**SUGGESTIONS FOR INSTRUCTION**

**Notes to the Teacher**

For a given pair of surfaces, the force of friction generally acts opposite to the direction of relative motion or attempted motion between the two surfaces. Note that a common misconception is that friction always acts to oppose motion (i.e., to make things stop moving). While friction usually does act to make things stop, it is also capable of making things move and speed up. An example of this would be a box sitting on a flatbed truck. If both were at rest when the truck gently accelerated forward, the inertial tendency of the box would be to remain at rest. An accelerating truck and a stationary box would produce rubbing between the two surfaces. Friction opposes this relative motion, causing the box to accelerate with the truck.

The direction of the friction force is not always immediately obvious, especially when there are multiple forces acting on an object initially at rest. In such cases, the direction of the tendency to slide must first be determined by finding the direction of the net force, ignoring friction.

Static friction occurs when the surfaces don't move relative to each other. Kinetic friction occurs between two surfaces that are moving relative to each other. Generally, the coefficient of static friction,  $\mu_s$ , is larger than the coefficient of kinetic friction,  $\mu_k$ .

**Teacher Demonstration**

Pull on a block with a spring scale and note the force just before the block moves (force necessary to overcome static friction). As you pull the block slowly across the table, compare the scale readings (kinetic friction).

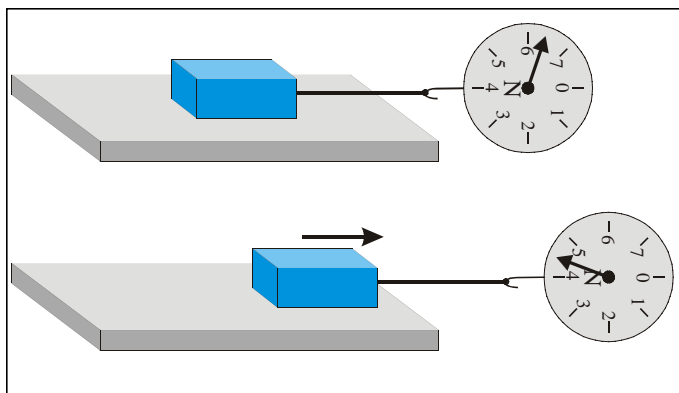

The coefficient of friction can be defined as:

$$\mu = \left( \frac{F_f}{F_N} \right)$$



**SKILLS AND ATTITUDES OUTCOME**

S3P-0-2g: Interpret patterns and trends in data, and infer or calculate linear relationships among variables.

**GENERAL LEARNING OUTCOME CONNECTION**

*Students will...*

**Understand how stability, motion, forces, and energy transfers and transformations play a role in a wide range of natural and constructed contexts (GLO D4)**

**SUGGESTIONS FOR INSTRUCTION**

The symbol  $\mu$  can be thought of as a numerical description of the nature of the surfaces. The equation  $\mu = 0$  corresponds to a frictionless surface: small values correspond to two surfaces that are slippery, with the friction becoming larger with larger values of  $\mu$ .

Note that the equations for friction can then be written as  $F_{fk} = \mu_k F_N$  and  $F_{fs} = \mu_s F_N$ .

Surprisingly, the force of friction only depends on three things, as discussed above (normal force, nature of surfaces, and whether the surfaces are rubbing or forces are attempting to cause rubbing).

The surface area and speed of motion do not generally change the force of friction.

**Extension**

For inclined planes, identify the normal force relevant to the object experiencing friction. The magnitude of the normal force is generally found using  $F_N = m \cdot g \cos\theta$ , where  $\theta$  is the angle between the horizontal and the inclined plane. Gravity exerts a force of  $F_a = m \cdot g \sin\theta$  on the object in a direction down the plane. Students can demonstrate that these equations are correct, using vector diagrams and trigonometry.

**SUGGESTIONS FOR ASSESSMENT****Research Report/Presentation**

Students perform a lab to determine the coefficient of friction for various materials, using the “angle of repose” method.

**SUGGESTED LEARNING RESOURCES****Software**

*Interactive Physics Simulations*, Activities #3: Free Fall; #6: Grape Drop

**Multimedia**

Videodiscs: *Physics at Work*: penny and feather

*Video Encyclopedia of Physics Demonstrations*: penny and feather

*Physics of Flight*: motion of free-fall parachutist



**GENERAL LEARNING OUTCOME CONNECTION**

*Students will...*

**Demonstrate appropriate scientific inquiry skills when seeking answers to questions (GLO C2)**

**SPECIFIC LEARNING OUTCOMES**

**S3P-4-09:** Describe terminal velocity, qualitatively and quantitatively.

**S3P-4-10:** Define the coefficient of friction ( $\mu$ ) as the ratio of the force of friction and the normal force.

**S3P-4-11:** Distinguish between static and kinetic friction.

**S3P-4-12:** Compare the effects of the normal force, materials involved, surface area, and speed on the force of friction.

**S3P-4-13:** Solve problems with the coefficient of friction for objects on a horizontal surface.

**SUGGESTIONS FOR INSTRUCTION**

**Student Activity: Coefficient of Static Friction (the following activity could be considered an optional extension)**

To find the coefficient of static friction, increase the angle of the incline until the object just begins to slide uniformly down the plane (see diagram). At this time, since acceleration is zero:

$$F_g = F_f$$

$$F_f = mg \sin\theta$$

And the normal force is the cosine component.

$$F_N = mg \cos\theta$$

Therefore, the coefficient of friction is

$$\mu = \frac{F_f}{F_N}$$

$$\mu_s = \frac{mg \sin\theta}{mg \cos\theta}$$

$$\mu_s = \frac{\sin\theta}{\cos\theta}$$

$$\mu_s = \tan\theta$$

where  $\theta$  is the angle of inclination.

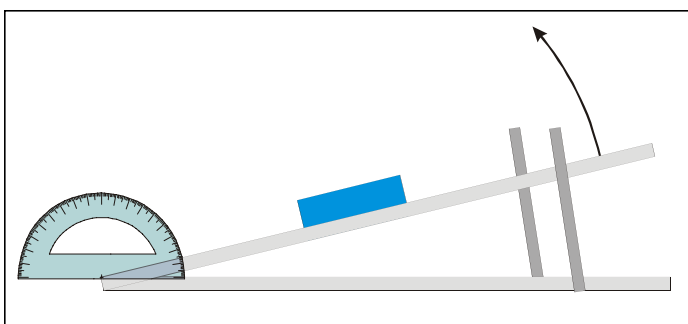

**SKILLS AND ATTITUDES OUTCOME**

S3P-0-2g: Interpret patterns and trends in data, and infer or calculate linear relationships among variables.

**GENERAL LEARNING OUTCOME CONNECTION**

*Students will...*

**Understand how stability, motion, forces, and energy transfers and transformations play a role in a wide range of natural and constructed contexts (GLO D4)**

**SUGGESTIONS FOR INSTRUCTION**

**SUGGESTIONS FOR ASSESSMENT**

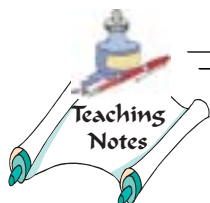

Empty box for suggestions for instruction.

Empty box for suggestions for assessment.

## NOTES



---

## **TOPIC 4.2: ELECTRIC FIELDS**

Students define the electric field strength,  $E$ , as a force per unit charge (in N/C). The electric force is given by  $F_e = qE$ , and lines of force are used to draw the field. The field between two parallel plates is described. Students examine problems involving both the gravitational and electric forces, and describe Millikan's experiment and the elementary charge.

The student will be able to:

S3P-4-14: Define the electric field qualitatively as the region of space around a charge where a positive test charge experiences a force.

S3P-4-15: Diagram electric fields using lines of force with respect to a positive test charge.

Include: single point charges (positive and negative), near two like charges, near two unlike charges, between a single charge and a charged plate, between two oppositely charged parallel plates

S3P-4-16: Define the electric field quantitatively as a force per unit charge ( $E = F/q$ ) and solve problems using the unit field concept ( $F = qE$ ).

S3P-4-17: Solve problems for the motion of charges between parallel plates where  $F_{\text{net}} = F_e + F_g$ .

S3P-4-18: Describe a simplified version of Millikan's experiment for the determination of the elementary charge (solve for charge when  $F_e = F_g$ ).

S3P-4-19: Define the elementary charge and convert between elementary charges and coulombs.

Include:  $q = Ne$

---



**GENERAL LEARNING OUTCOME CONNECTION**

*Students will...*

**Employ effective communication skills and utilize information technology to gather and share scientific and technological ideas and data (GLO C6)**

**SPECIFIC LEARNING OUTCOMES**

**S3P-4-14:** Define the electric field qualitatively as the region of space around a charge where a positive test charge experiences a force.

**S3P-4-15:** Diagram electric fields using lines of force with respect to a positive test charge.

Include: single point charges (positive and negative), near two like charges, near two unlike charges, between a single charge and a charged plate, between two oppositely charged parallel plates

**SUGGESTIONS FOR INSTRUCTION**

**Entry-Level Knowledge**

Students are introduced to electrostatics in Senior 1 Science.

**Notes to the Teacher**

Describe the electric field as a force per unit charge, and compare to the concept of the gravitational field and mass. Emphasize that an electric field can result from either a negative or a positive charge. Distinguish carefully between the charge that establishes the field and the test charge that experiences the force. The direction of the field can be confusing as it is always described as if the test charge is positive. Therefore, the electric field vector and the electric force vector are *in the same direction* if the charge brought into the field is positive, and *in opposite directions* if the charge is negative. Note that a line of force indicates the direction the force would act on a positive test charge in the field. Note also that the number of lines per unit area represents the intensity of the field.

Demonstrate the electric fields around charged objects with grass seeds, "fuzzy fur," or fibre clippings. Fine pieces of fibre clippings can be suspended in mineral oil between a pair of electrodes and the pattern projected on the overhead.

**Teacher Demonstration**

Demonstrate electric fields with a Van der Graff machine and a collection of threads, streamers, or light strips of paper.

***Senior Years Science Teachers' Handbook Activities***

Students compare and contrast electric and gravitational fields. While gravitational fields always exert attractive forces on other masses, an electric field may exert repulsive forces as well. (See *Senior Years Science Teachers' Handbook*, Compare and Contrast Frame, page 10.24.)



**SKILLS AND ATTITUDES OUTCOMES**

S3P-0-2a: Select and use appropriate visual, numeric, graphical, and symbolic modes of representation to identify and represent relationships.

S3P-0-2c: Formulate operational definitions of major variables or concepts.

**GENERAL LEARNING OUTCOME CONNECTION**

*Students will...*

**Understand how stability, motion, forces, and energy transfers and transformations play a role in a wide range of natural and constructed contexts (GLO D4)**

**SUGGESTIONS FOR INSTRUCTION**

**SUGGESTIONS FOR ASSESSMENT**

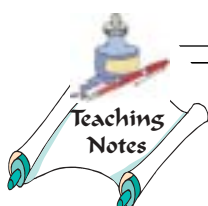

A large empty rectangular box for providing suggestions for instruction.

**SUGGESTED LEARNING RESOURCES**

Lapp, D.R. (1996) "Field Lines Flying Fur." *The Physics Teacher* 34.4: 252.

**Software**  
 Exploring Electrodynamics;  
 Explorations 1-2: Electric Field  
*EM Field 6*, Physics Academic Software Publishing Organization

**Multimedia**  
 Videodisc: *Video Encyclopedia of Physics Demonstrations*: Demo 17-10, Electric Field



**GENERAL LEARNING OUTCOME CONNECTION**

Students will...

**Understand how stability, motion, forces, and energy transfers and transformations play a role in a wide range of natural and constructed contexts (GLO D4)**

**SPECIFIC LEARNING OUTCOME**

**S3P-4-16:** Define the electric field quantitatively as a force per unit charge ( $E = F/q$ ) and solve problems using the unit field concept ( $F = qE$ ).

**SUGGESTIONS FOR INSTRUCTION**

**Notes to the Teacher**

The electric force ( $F_E = qE$ ) can be found in the same way as the weight of an object, given the gravitational field. Emphasize the unit concept (unit charge, unit mass). The electric field describes the number of newtons each coulomb of charge experiences at some point. Note carefully the direction of the electric force as it compares to the electric field. The direction of the electric field is always given as if it acts on positive test charges. Consequently, the electric field vector and the electric force vector are *in the same direction* if the charge brought into the field is positive. However, if the charge brought into the field is negative, then the electric field vector and the electric force vector are *in opposite directions*.

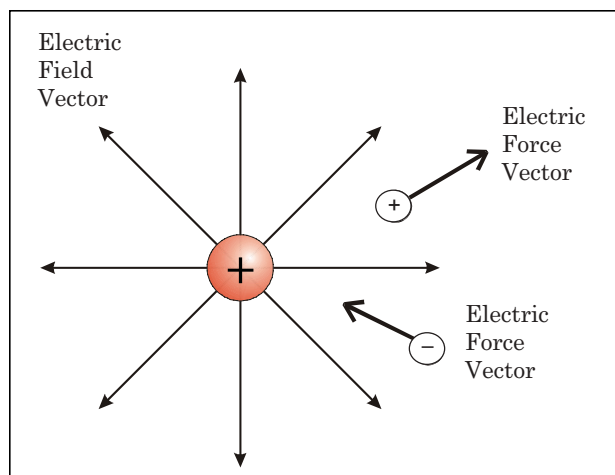

**Illustrative Example**

A charged pith ball is brought near a charged sphere. Calculate the electric field, using  $F_E/q$ , where  $F_E = mg \tan \theta$ , and  $\theta$  is the angle of deflection of the pith ball.

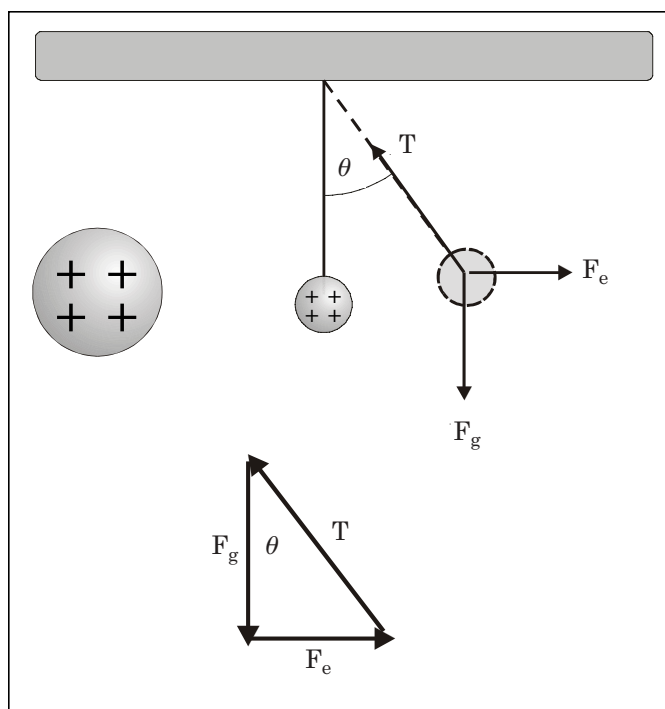

**Note:** The scale in the illustrative example is exaggerated for simplicity.



**SKILLS AND ATTITUDES OUTCOMES**

S3P-0-2c: Formulate operational definitions of major variables or concepts.

S3P-0-2h: Analyze problems, using vectors.

Include: adding and subtracting vectors in straight lines and at right angles, vector components

**GENERAL LEARNING OUTCOME CONNECTION**

*Students will...*

**Understand how stability, motion, forces, and energy transfers and transformations play a role in a wide range of natural and constructed contexts (GLO D4)**

**SUGGESTIONS FOR INSTRUCTION**

**SUGGESTIONS FOR ASSESSMENT**

***Senior Years Science Teachers' Handbook Activities***

**Journal Entry:** Students compare and contrast the idea of a field (a force per unit “something”) to the concept of a unit price in a grocery store.

**Paper-and-Pencil Tasks**

Students solve problems with  $F_E = qE$ .

**SUGGESTED LEARNING RESOURCES**

**Software**

*Exploring Electrodynamics;*  
 Explorations 1-2: Electric Field;  
 Independent Exploration: Millikan Experiment; Core Activity 1: Electric Field and Force

**Multimedia**

Videodisc: *Physics at Work*: Side A/B, Frames 1853-60, Electric fields  
 Videodisc: *Video Encyclopedia of Physics Demonstrations*: Demo 17-10, Electric Field  
 Video: *Beyond the Mechanical Universe: From Electricity to Modern Physics*: #3: The Electric Field; #10: Vector Fields and Hydrodynamics



**GENERAL LEARNING OUTCOME CONNECTION**

*Students will...*

**Demonstrate appropriate scientific inquiry skills when seeking answers to questions (GLO C2)**

**SPECIFIC LEARNING OUTCOME**

**S3P-4-17:** Solve problems for the motion of charges between parallel plates where

$$F_{\text{net}} = F_e + F_g .$$

**SUGGESTIONS FOR INSTRUCTION**

**Notes to the Teacher**

Identify the constant field between parallel plates by first considering a line of charge and a single point charge placed nearby. The horizontal components of corresponding charges cancel and the vertical components add. For oppositely charged plates, the effect is enhanced. The field is constant and is directed from the positive to the negative plate. The edges of the field bulge slightly since there are no charges outside the plates to balance the horizontal effects of the nearby charges.

Since the electric field between parallel plates is constant, we may use all of the kinematic relations derived in 3.1.7 and Newton's Second Law to solve problems for charges that are moving between the plates. In Senior 3 Physics, students should only consider charges that are moving in a straight line between the plates. Problems can include solving for charge, electric field strength ( $E$ ), electric force ( $F_E$ ), mass, gravitation force ( $F_g$ ), net force, acceleration, final velocity, or displacement.

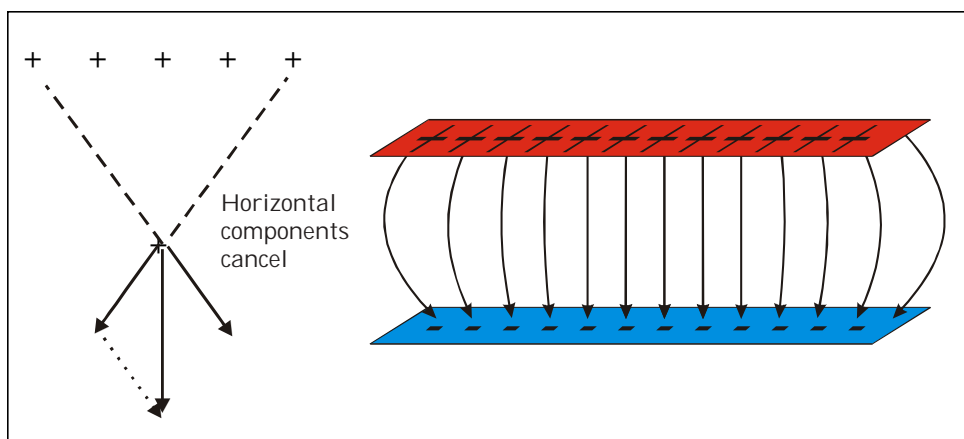

**SKILLS AND ATTITUDES OUTCOMES**

S3P-0-2c: Formulate operational definitions of major variables or concepts.

S3P-0-2h: Analyze problems, using vectors.

Include: adding and subtracting vectors in straight lines and at right angles, vector components

**GENERAL LEARNING OUTCOME CONNECTION**

*Students will...*

**Understand how stability, motion, forces, and energy transfers and transformations play a role in a wide range of natural and constructed contexts (GLO D4)**

**SUGGESTIONS FOR INSTRUCTION**

**SUGGESTIONS FOR ASSESSMENT**

**Student Activities**

Students predict the path of a particle in an electric field, using *Exploring Electrodynamics* Explorations 1 and 2.

***Senior Years Science Teachers' Handbook Activities***

See Compare and Contrast, *Senior Years Science Teachers' Handbook*, Building a Scientific Vocabulary, page 10.15.

**SUGGESTED LEARNING RESOURCES**

Bonham, S. (1999) "Using Physlets to Teach Electrostatics." *The Physics Teacher* 37.5: 276.

Concept Overview, Attachment 19, *Success for All Learners: A Handbook on Differentiating Instruction*.



**GENERAL LEARNING OUTCOME CONNECTION**

*Students will...*

Identify and appreciate contributions made by women and men from many societies and cultural backgrounds towards increasing our understanding of the world and in bringing about technological innovations (GLO A4)

**SPECIFIC LEARNING OUTCOMES**

**S3P-4-18:** Describe a simplified version of Millikan's experiment for the determination of the elementary charge (solve for charge when  $F_e = F_g$ ).

**S3P-4-19:** Define the elementary charge and convert between elementary charges and coulombs.

Include:  $q = Ne$

**SUGGESTIONS FOR INSTRUCTION**

**Notes to the Teacher**

Millikan's experiment can be diagrammed and described, or demonstrated using animations.

Define the elementary charge. Convert between elementary charges and coulombs. The coulomb is actually defined operationally by the force of attraction between two current-carrying wires. However, at this point, introduce the coulomb as a fixed number of elementary charges ( $1\text{C} = 6.25 \times 10^{18}$  elementary charges). Therefore, in coulombs, one elementary charge is:

$$q = N \times e$$

$$1\text{ C} = 6.25 \times 10^{18} e$$

and

$$e = \frac{1}{6.25 \times 10^{18}} \text{ C}$$

$$e = 1.6 \times 10^{-19} \text{ C}$$

An elementary charge is the charge of an electron ( $-e$ ) or a proton ( $+p$ ).

Solve for the quantity of charge ( $q$ ), electric force ( $F_e$ ), mass, gravitational force ( $F_g$ ), number and type (proton/electrons) of elementary charge ( $N$ ) for Millikan-type problems.

In terms of Newton's Second Law, for a small sphere placed between the plates, we have:

$$F_{\text{net}} = F_{\text{applied}} + F_{\text{friction}}$$

such that

$$F_{\text{friction}} = 0 \text{ (negligible) and}$$

$$F_{\text{applied}} = F_e + F_g$$

There are several cases to address for charges between parallel plates:

$F_e = -F_g$  (the sphere is stationary between the plates)

$F_e < F_g$  (opposite to  $F_g$  such that  $a < g$ )

$F_e > F_g$  (opposite to  $F_g$  such that  $a > 0$  [upwards])

$F_e > 0$  (in the same direction as  $F_g$  such that  $a > g$ )



**SKILLS AND ATTITUDES OUTCOME**

S3P-0-1b: Describe the importance of peer review in the evaluation and acceptance of scientific theories, evidence, and knowledge claims.

**GENERAL LEARNING OUTCOME CONNECTION**

*Students will...*

Describe scientific and technological developments, past and present, and appreciate their impact on individuals, societies, and the environment, both locally and globally (GLO B1)

**SUGGESTIONS FOR INSTRUCTION**

**SUGGESTIONS FOR ASSESSMENT**

**Illustrative Example**

A negatively charged  $2.0 \times 10^{-5}$  kg droplet of oil is placed between two oppositely charged plates. The oil drop is balanced when the electric field is adjusted to  $4.2 \times 10^{-7}$  N/C.

- a) Diagram to indicate the charge on each plate.
- b) How many elementary charges are on the oil drop?

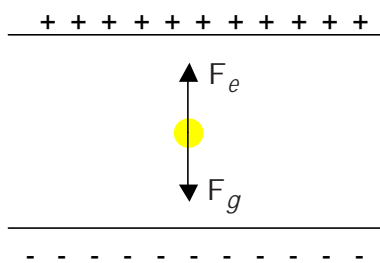

$m = 2.0 \times 10^{-7}$  kg

$E = 4.2 \times 10^5$  N/C

**Pencil-and-Paper Tasks**

Written Test: Students solve for charge when  $F_e = F_g$ .

**Visual Displays**

Students diagram the different possibilities for charge, plates, forces, and acceleration.

**SUGGESTED LEARNING RESOURCES**

**Software**

*Millikan Oil Drop Experiment*: Vernier CBL system.

**Multimedia**

Video: *The Mechanical Universe: Introductory Physics*: #12: The Millikan Experiment

Videodisc: *Video Encyclopedia of Physics Demonstrations*: Demo 24-24: Millikan Oil Drop

**Websites**

Search for "Millikan applets" using the keywords: Millikan's experiment + applet





**GENERAL LEARNING OUTCOME CONNECTION**

*Students will...*

Identify and appreciate contributions made by women and men from many societies and cultural backgrounds towards increasing our understanding of the world and in bringing about technological innovations (GLO A4)

**SPECIFIC LEARNING OUTCOMES**

**S3P-4-18:** Describe a simplified version of Millikan’s experiment for the determination of the elementary charge (solve for charge when  $F_e = F_g$ ).

**S3P-4-19:** Define the elementary charge and convert between elementary charges and coulombs.

Include:  $q = Ne$

**SUGGESTIONS FOR INSTRUCTION**

Since the drop is balanced,

$$F_e = F_g$$

$$qE = mg$$

$$q = \frac{2.0 \times 10^{-7} (9.8)}{4.2 \times 10^5 \text{ N/C}}$$

$$q = 4.7 \times 10^{-13} \text{ C}$$

Since  $q = Ne$ ,

$$N = \frac{4.7 \times 10^{-13} \text{ C}}{1.6 \times 10^{-19} \text{ C}}$$

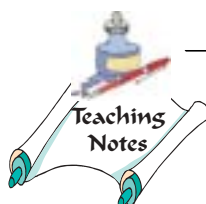

**Senior Years Science Teachers’ Handbook Activities**

Anticipation Guide: Students read Douglas Allchin’s article “Flirting with Fraud: Millikan, Mendel and the Fringes of Integrity” in Appendix 4.4. Use the question, “Was Millikan’s selective use of data ‘good’ science?” to address the Nature of Light outcome S3P-0-1b (scientific knowledge claims).

See Appendix 4.4: Student Article Analysis—Scientific Fraud?



**SKILLS AND ATTITUDES OUTCOME**

S3P-0-1b: Describe the importance of peer review in the evaluation and acceptance of scientific theories, evidence, and knowledge claims.

**GENERAL LEARNING OUTCOME CONNECTION**

*Students will...*

**Describe scientific and technological developments, past and present, and appreciate their impact on individuals, societies, and the environment, both locally and globally (GLO B1)**

**SUGGESTIONS FOR INSTRUCTION**

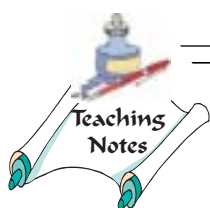

**SUGGESTIONS FOR ASSESSMENT**

**Understanding the Major Explanatory Stories of Science**

Access the following URL for an article related to the integrity of earlier work in electric fields that could be suitable for a student article analysis:

<<http://www1.umn.edu/ships/updates/fraud.htm>>

The article, "Flirting with Fraud: Millikan, Mendel and the Fringes of Integrity" by Douglas Allchin, is also reprinted in Appendix 4.4.



## NOTES



---

## ***TOPIC 4.3: MAGNETIC FIELDS***

The student will be able to:

- S3P-4-20: Define the magnetic field as the region of space around a magnet where another magnet will experience a force.
  - S3P-4-21: Demonstrate and diagram magnetic fields, using lines of force.  
Include: bar magnet, horseshoe magnet, between like poles, between unlike poles
  - S3P-4-22 Describe the concept of magnetic poles and demonstrate that like poles repel and unlike poles attract.
  - S3P-4-23: Describe magnetism, using the domain theory.  
Include: ferromagnetic materials, the attraction of iron objects to north and south poles
  - S3P-4-24: Investigate the influence and effects of the magnetic field of the Earth.  
Include: auroras, magnetic declination and inclination
-

**GENERAL LEARNING OUTCOME CONNECTION**

*Students will...*

**Employ effective communication skills and utilize information technology to gather and share scientific and technological ideas and data (GLO C6)**

**SPECIFIC LEARNING OUTCOMES**

**S3P-4-20:** Define the magnetic field as the region of space around a magnet where another magnet will experience a force.

**S3P-4-21:** Demonstrate and diagram magnetic fields, using lines of force.

Include: bar magnet, horseshoe magnet, between like poles, between unlike poles

**SUGGESTIONS FOR INSTRUCTION**

**Entry-Level Knowledge**

Students have completed treatment of the concepts of gravitational and electric fields.

**Notes to the Teacher**

The field concept is useful in describing and relating magnetic fields to gravitational and electric fields. By this time, students should be familiar with the basic field concept. However, an introduction to the basics of magnetism is required at this point.

While we cannot easily “demonstrate” electric and gravitational field lines, we can easily map magnetic fields, using magnets and iron filings. This visual aspect of magnetic fields helps to reinforce the previous discussions of field lines.

In magnetic fields, a line of force indicates the direction the force would act on a north pole in the field. The number of lines per unit area represents the intensity of the field.

**Student Activities**

A lab on basic magnetism is essential. Field mapping should be included in the activity.

The cardboard backing from a ream of paper can be placed over a magnet. Iron filings are sprinkled on the cardboard. By tapping the cardboard lightly, the iron filings line up along the magnetic field lines. Different configurations can be used (e.g., horseshoe magnet, two like poles, two unlike poles).

**Teacher Demonstration**

Place a magnet under a piece of Plexiglas® and sprinkle iron filings around the magnet on top of the Plexiglas®. The field can be projected on an overhead.

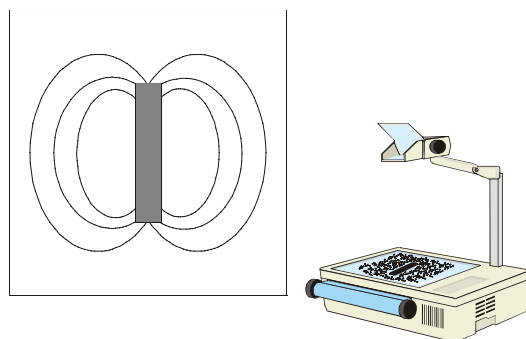

**SKILLS AND ATTITUDES OUTCOME**

S3P-0-2c: Formulate operational definitions of major variables or concepts.

**GENERAL LEARNING OUTCOME CONNECTION**

*Students will...*

**Evaluate, from a scientific perspective, information and ideas encountered during investigations and in daily life (GLO C8)**

**SUGGESTIONS FOR INSTRUCTION**

**SUGGESTIONS FOR ASSESSMENT**

***Senior Years Science Teachers' Handbook Activities***

**Journal Entry:** Students respond in their journals to questions (e.g., in your home, where do you find magnetic fields, gravitational fields, electric fields? List some examples of each field.).

**Compare and Contrast Frames:** Students answer the following questions: What is the same about gravitational, electric, and magnetic fields? What is different?

**Laboratory Report**

Students write a lab report including diagrams of various fields from a variety of magnet types.

**SUGGESTED LEARNING RESOURCES**

*AAPT Potpourri of Physics Teaching Ideas*, 160–168.

Kagan, D. (1993) "Building a Magnetic Levitation Toy." *The Physics Teacher* 31: 432.



**GENERAL LEARNING OUTCOME CONNECTION**

*Students will...*

**Recognize that scientific knowledge is based on evidence, models, and explanations, and evolves as new evidence appears and new conceptualizations develop (GLO A2)**

**SPECIFIC LEARNING OUTCOMES**

**S3P-4-22:** Describe the concept of magnetic poles and demonstrate that like poles repel and unlike poles attract.

**S3P-4-23:** Describe magnetism, using the domain theory.

Include: ferromagnetic materials, the attraction of iron objects to north and south poles

**SUGGESTIONS FOR INSTRUCTION**

**Notes to the Teacher**

Students may not have had a hands-on opportunity to investigate magnetism. Introduce magnetism, using a hands-on lab.

The domain theory is a simple model of magnetism, which states that all materials are made up of tiny regions called domains. The domains behave like magnets. When they are distributed randomly their magnetic effects cancel, and when the domains become aligned the material is magnetized.

Additionally, the domains that are already with the field can grow in size, while those not aligned shrink due to the atoms on the boundary (the domain “wall”).

**Student Activity**

Students suspend a magnet from a pivot and bring another magnet nearby to demonstrate attraction and repulsion of like and unlike poles.

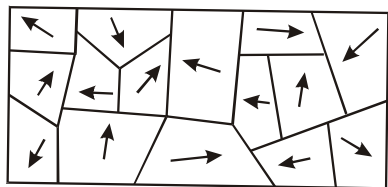

Domains aligned randomly (no magnetic effects)

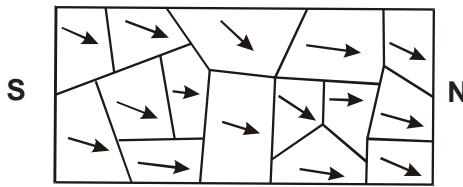

Domains aligned



**SKILLS AND ATTITUDES OUTCOMES**

S3P-0-2c: Formulate operational definitions of major variables or concepts.

S3P-0-2f: Record, organize, and display data using an appropriate format.

Include: labelled diagrams, tables, graphs

**GENERAL LEARNING OUTCOME CONNECTION**

*Students will...*

**Understand how stability, motion, forces, and energy transfers and transformations play a role in a wide range of natural and constructed contexts (GLO D4)**

**SUGGESTIONS FOR INSTRUCTION**

**SUGGESTIONS FOR ASSESSMENT**

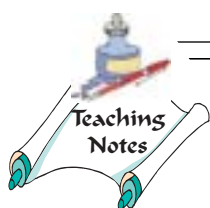

A large empty rectangular box for providing suggestions for instruction.

**Research Report/Presentation**

Students complete a research report on magnetic phenomena, using diagrams to illustrate concepts.

**Recognizing the Role of Evidence**

Students discuss their personal understanding of what a magnetic field represents, and resolve competing diagrams.

**SUGGESTED LEARNING RESOURCES**

Appendix 4.3: Student Sampler: Magnetic Fields





**GENERAL LEARNING OUTCOME CONNECTION**

*Students will...*

**Demonstrate appropriate scientific inquiry skills when seeking answers to questions (GLO C2)**

**SPECIFIC LEARNING OUTCOME**

**S3P-4-24:** Investigate the influence and effects of the magnetic field of the Earth.

Include: auroras, magnetic declination and inclination

**SUGGESTIONS FOR INSTRUCTION**

**Notes to the Teacher**

Ancient mariners believed that somewhere in the north was a magnetic mountain that was the source of attraction for their compasses. It was not until 1600 that William Gilbert, in his treatise *Physiologia Nova de Magnete*, suggested that the Earth itself behaved like a giant magnet. In simple terms, the Earth can be thought of as a bar magnet and the force that attracts the compass originates inside the Earth.

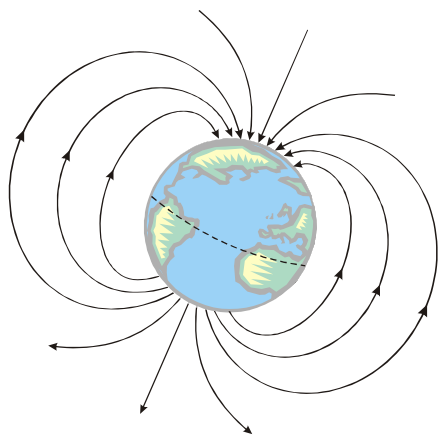

Magnetic field lines radiate between Earth's north and south magnetic poles. Magnetic fields are produced by the motion of electrical charges (see the next unit on electromagnetism). The Earth's magnetic field is not completely understood, but is thought to be associated with electrical

currents produced by the rotational effects in the liquid outer core of Earth's interior. Consequently, the Earth's magnetic field reverses itself approximately every 250,000 years.

Auroras (the northern and southern lights) are caused by high-energy particles from the solar wind trapped in the Earth's magnetic field. As these particles oscillate along the magnetic field lines, they enter the atmosphere near the north and south magnetic poles. These energetic electrons collide with the oxygen and nitrogen molecules in the atmosphere. The collisions excite the molecules and, when they decay from the excited states, they emit the light that we see in the auroras.

The magnetic poles are not in the same location as the geographic poles. Declination is the angle between true north and magnetic north. This angle changes, depending on your location. For example, it is 20°E in Victoria, B.C., but in St. John's, Newfoundland, it is 23°W. Knowledge of magnetic declination is important for navigational purposes. According to the National Geomagnetism Program, the north magnetic pole is a feature unique to Canada, and monitoring its position and motion is of prime importance to Canadian cartography.



**SKILLS AND ATTITUDES OUTCOME**

S3P-0-1c: Relate the historical development of scientific ideas and technology to the form and function of scientific knowledge today.

**GENERAL LEARNING OUTCOME CONNECTION**

*Students will...*

**Understand how stability, motion, forces, and energy transfers and transformations play a role in a wide range of natural and constructed contexts (GLO D4)**

**SUGGESTIONS FOR INSTRUCTION**

At each location on the Earth, the magnetic field lines intersect the Earth's surface at a specific angle of inclination. Near the equator, the field lines are approximately parallel to the Earth's surface (see diagram below) and the inclination angle in this region is close to  $0^\circ$ . As one travels north from the equator, the angle of inclination increases. At the magnetic pole, the field lines are directed almost straight down into the Earth and the inclination is  $90^\circ$ . Thus, the angle of inclination varies with latitude. It has been suggested that some animals have the ability to distinguish between magnetic inclination angles and therefore "know" their latitude, particularly migratory animals.

Magnetic inclination (also called the magnetic dip) is the angle that the geomagnetic field makes with the surface of the Earth. Magnetic inclination varies from  $90^\circ$  (perpendicular to the surface) at the magnetic poles to  $0^\circ$  at the equator.

**SUGGESTIONS FOR ASSESSMENT****Research Report/Presentation**

Students research and report on the characteristics of magnetic fields of other planets in our solar system.

**Science Journal Entries**

Students research Earth's "dynamo" mechanism, and use the results to explain why Venus has no field and why the Sun has an oscillating field.

**SUGGESTED LEARNING RESOURCES****Websites**

Geomagnetism:

<<http://www.ngdc.noaa.gov/seg/potfld/geomag.shtml>>

Geology: Plate Tectonics:

<<http://www.earth.nwu.edu/people/seth/107/>>

<<http://www.platetectonics.com/index.asp>>

When the Earth Moves—Discoveries in Plate Tectonics and Seafloor Spreading:

<<http://www.beyonddiscovery.org/>>

Plate Tectonics—A Paradigm Under Threat:

<<http://ourworld.compuserve.com/homepages/dp5/tecto.htm>>



**GENERAL LEARNING OUTCOME CONNECTION**

*Students will...*

**Demonstrate appropriate scientific inquiry skills when seeking answers to questions (GLO C2)**

**SPECIFIC LEARNING OUTCOME**

**S3P-4-24:** Investigate the influence and effects of the magnetic field of the Earth.

Include: auroras, magnetic declination and inclination

---

**SUGGESTIONS FOR INSTRUCTION**

When magnetic minerals are free to reorient themselves, they can align with the Earth's magnetic field. As molten rock containing ferromagnetic minerals (e.g., magnetite) cools below the Curie Point, the iron-bearing mineral grains preferentially orient themselves to the prevailing magnetic field of Earth. This orientation becomes locked in place as the rocks cool and harden. This magnetic inclination allows geologists to speculate about where on the globe a volcanic rock might have formed. Unfortunately, only the approximate latitude at the time of formation of the rock can be "locked in"—not the longitudinal position on the globe.

During the 1950s and 1960s, the science of *paleomagnetism* provided crucial novel facts to the development of new theories about the mobility of the ocean floors. Eventually, it was the rock magnetic data that turned many geologists away from the acceptance of permanent continents and oceans to the more innovative notions of continental drift, sea-floor spreading, and the theory of plate tectonics in the early 1970s. See the references for further sources on this connection between physics and geology.

**Student Activities**

Students can address several questions with respect to the study of paleomagnetism.

- What magnetic orientations would we expect to see in rocks at different spots on the Earth's surface, such as the north pole, Manitoba's north, or the Equator?
- What conditions must exist for the minerals to move around and thus be able to align themselves with the Earth's magnetic field?
- How does a rock preserve the magnetic orientation of its iron-bearing minerals?
- If we were to measure the inclination angle recorded in volcanic rocks, where on the Earth would we note a 0-degree angle of inclination? How about 90 degrees down? How about 90 degrees up?

**Senior Years Science Teachers' Handbook Activities**

Students research contributions of early Arctic explorers in locating the true magnetic north (e.g., Sir John Ross, Roald Amundsen).



**SKILLS AND ATTITUDES OUTCOME**

S3P-0-1c: Relate the historical development of scientific ideas and technology to the form and function of scientific knowledge today.

**GENERAL LEARNING OUTCOME CONNECTION**

*Students will...*

**Understand how stability, motion, forces, and energy transfers and transformations play a role in a wide range of natural and constructed contexts (GLO D4)**

**SUGGESTIONS FOR INSTRUCTION**

**SUGGESTIONS FOR ASSESSMENT**

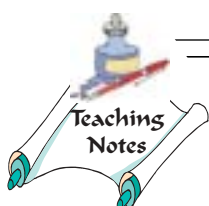

A large empty rectangular box for writing teaching notes, positioned below the 'Teaching Notes' icon.

**Major Explanatory Stories of Science**

Students explore the contents of William Gilbert's tract *Physiologia Nova de Magnete* of 1628, and describe details of his "physiological" approach to understanding magnetic phenomena. Produce a "tract" or pamphlet for distribution to Grade 3 students in your community who also study magnetism. (See Appendix 4.5: William Gilbert and the Earth's Magnetic Field.)

**SUGGESTED LEARNING RESOURCES**

**Websites**

Many interesting photos of auroras can be found in the astronomy picture of the day archive at: <<http://antwrp.gsfc.nasa.gov/apod/archivepix.html>>

For an aurora over Winnipeg, see: <<http://antwrp.gsfc.nasa.gov/apod/ap011105.html>>.

**References**

Brush, Steven. (1997) "Whole Earth History." *Historical Studies in the Physical Sciences* 17.2: 345-355.  
<<http://punsterproductions.com/~sciencehistory/WEH.htm>>

Appendix 4.5: William Gilbert and the Earth's Magnetic Field

## NOTES



---

## **TOPIC 4.4: ELECTROMAGNETISM**

The student will be able to:

- S3P-4-25: Describe and demonstrate the phenomenon of electromagnetism.
  - S3P-4-26: Diagram and describe qualitatively the magnetic field around a current-carrying wire.  
Include: direction and intensity of the field
  - S3P-4-27: Diagram and describe qualitatively the magnetic field of a solenoid.  
Include: direction and intensity of the field
  - S3P-4-28: Describe and demonstrate the function of an electromagnet.  
Include: common applications of electromagnets
  - S3P-4-29: Perform a lab to demonstrate that  $B \propto I$  for an electromagnetic field.
  - S3P-4-30: Describe the force on a current-carrying conductor in a magnetic field.  
Include:  $F_B = BII \sin\theta$
  - S3P-4-31: Define the magnetic field quantitatively as a force per unit current element (i.e.,  $B = F_B/I \mathbf{I}$ , where  $I \mathbf{I}$  is a current element).
  - S3P-4-32: Solve problems, using  $F_B = BII$ .
-

**GENERAL LEARNING OUTCOME CONNECTION**

*Students will...*

**Understand how stability, motion, forces, and energy transfers and transformations play a role in a wide range of natural and constructed contexts (GLO D4)**

**SPECIFIC LEARNING OUTCOME**

**S3P-4-25:** Describe and demonstrate the phenomenon of electromagnetism.

---

**SUGGESTIONS FOR INSTRUCTION**

**Notes to the Teacher**

Today we use electromagnetism in just about every aspect of our lives that depends on electricity. Electromagnetism works on the principle that moving charges generate a magnetic field. This magnetic field is the same force that is demonstrated by permanent magnets.

The domain theory should be related to the motion of the electron.

**Demonstration**

Hans Christian Oersted's discovery of electromagnetism can be demonstrated by placing a compass near a current-carrying conductor. The magnetic field around the wire causes the compass to deflect. However, if we turn the current off, the compass returns to a north-south alignment.

Suspend a 0.5-m long x 0.05-m wide strip of aluminum foil between the poles of a magnet. Connect a low-voltage power source (0-3 A) to the ends of the foil. The force acting on the current-carrying aluminum will "levitate" the foil.



**SKILLS AND ATTITUDES OUTCOME**

S3P-0-4e: Demonstrate a continuing and more informed interest in science and science-related issues.

**GENERAL LEARNING OUTCOME CONNECTION**

*Students will...*

**Understand how stability, motion, forces, and energy transfers and transformations play a role in a wide range of natural and constructed contexts (GLO D4)**

**SUGGESTIONS FOR INSTRUCTION**

**SUGGESTIONS FOR ASSESSMENT**

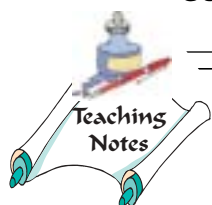

Empty box for suggestions for instruction.

Empty box for suggestions for assessment.





**GENERAL LEARNING OUTCOME CONNECTION**

*Students will...*

**Evaluate, from a scientific perspective, information and ideas encountered during investigations and in daily life (GLO C8)**

**SPECIFIC LEARNING OUTCOMES**

**S3P-4-26:** Diagram and describe qualitatively the magnetic field around a current-carrying wire.

Include: direction and intensity of the field

**S3P-4-27:** Diagram and describe qualitatively the magnetic field of a solenoid.

Include: direction and intensity of the field

**S3P-4-28:** Describe and demonstrate the function of an electromagnet.

Include: common applications of electromagnets

**SUGGESTIONS FOR INSTRUCTION**

**Notes to the Teacher**

The magnetic field around a current-carrying wire forms concentric circles around the wire. The direction of the magnetic field is given by the “right-hand” rule: When the thumb of the right hand points in the direction of the conventional current, the fingers curl around the wire in the direction of the magnetic field.

**Note:** Some texts use a “left-hand” rule and the electron current.

If the wire is formed into a loop, the magnetic field around all parts of the wire contributes to the field in the middle of the loop, making it stronger. The magnetic field increases as we add more loops (solenoid). The field inside the solenoid is more intense, is constant, and is directed straight through the middle of the solenoid. The direction of the field is found by the “right-

hand” rule. If the fingers curl in the direction of the conventional current, the thumb points in the direction of the field.

**Teacher Demonstration**

Various experiments and demonstrations can be used to describe the fields around a current-carrying wire. If the wire is wound through Plexiglas®, the fields can be displayed on the overhead.

The field of a solenoid can be intensified by placing an iron core inside the solenoid (i.e., an electromagnet). The permeability of an electromagnet describes how many times the field is intensified with the core.

**Student Activities**

Students can build a simple electromagnet.

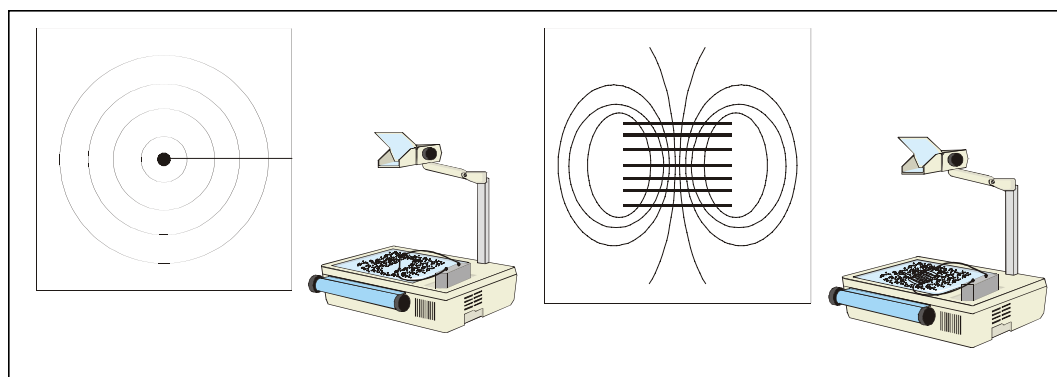

**SKILLS AND ATTITUDES OUTCOMES**

S3P-0-3b: Describe examples of how technology has evolved in response to scientific advances, and how scientific knowledge has evolved as the result of new innovations in technology.

S3P-0-2b: Propose problems, state hypotheses, and plan, implement, adapt, or extend procedures to carry out an investigation where required.

**GENERAL LEARNING OUTCOME CONNECTION**

*Students will...*

**Understand how stability, motion, forces, and energy transfers and transformations play a role in a wide range of natural and constructed contexts (GLO D4)**

**SUGGESTIONS FOR INSTRUCTION**

**SUGGESTIONS FOR ASSESSMENT**

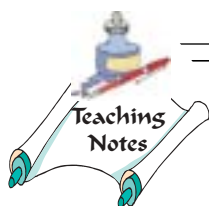

A large empty rectangular box for writing suggestions for instruction.

The concept of electromagnetism can also be combined with learning outcomes from the Waves topic to design, construct (or assemble), test, and demonstrate a technological device to produce, transmit, and/or control sound waves for a useful purpose.



**GENERAL LEARNING OUTCOME CONNECTION**

*Students will...*

**Demonstrate appropriate scientific inquiry skills when seeking answers to questions (GLO C2)**

**SPECIFIC LEARNING OUTCOMES**

**S3P-4-29:** Perform a lab to demonstrate that  $B \propto I$  for an electromagnetic field.

**S3P-4-30:** Describe the force on a current-carrying conductor in a magnetic field.

Include:  $F_B = BI \sin\theta$

**S3P-4-31:** Define the magnetic field quantitatively as a force per unit current element (i.e.,  $B = F_B/II$ , where  $II$  is a current element).

**S3P-4-32:** Solve problems, using  $F_B = BI$ .

**SUGGESTIONS FOR INSTRUCTION**

**Notes to the Teacher**

There are several labs that can be followed to achieve this learning outcome.

- The tangent galvanometer lab can be used to demonstrate the relationship between current and magnetic fields.
- The current balance can be used to find the relationship between  $F$ ,  $B$ ,  $I$ , and  $l$  for a wire and can be used to derive the field as a force per unit current element.

**Student Activities**

Using a digital scale, students place two opposite poles on the balance and zero the balance. Suspend a wire between the poles and connect to a power source. The magnetic force on the wire when a current is in the wire will be equal to the increase in scale reading times 9.8.

- Graph the relationship between force and current element ( $Il$ ). The slope of the line is the magnetic field constant  $B$ .
- If the length of wire between the poles is increased (place two additional poles nearby), the force increases proportionally.

**Teacher Demonstration**

The Jumping Wire (HOT wire Caution!)

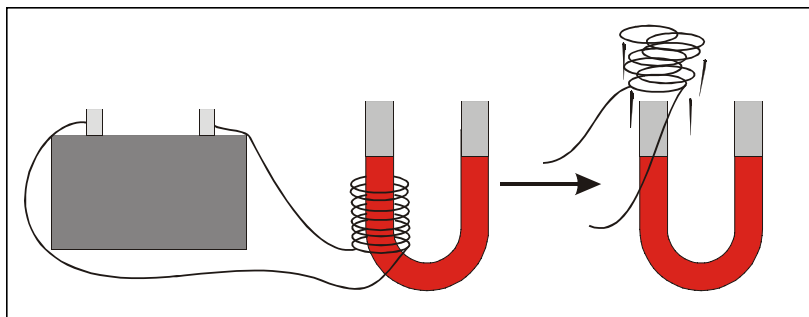

**SKILLS AND ATTITUDES OUTCOMES**

S3P-0-2e: Evaluate the relevance, reliability, and adequacy of data and data-collection methods.

Include: discrepancies in data and sources of error

S3P-0-2g: Interpret patterns and trends in data, and infer or calculate linear relationships among variables.

**GENERAL LEARNING OUTCOME CONNECTION**

*Students will...*

**Demonstrate appropriate critical thinking and decision-making skills when choosing a course of action based on scientific and technological information (GLO C4)**

**SUGGESTIONS FOR INSTRUCTION**

**SUGGESTIONS FOR ASSESSMENT**

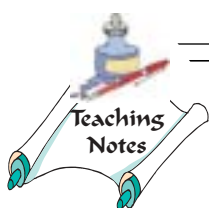

**Journal Entries**

Students diagram the field around a conductor, tangent galvanometer, current balance.

**Performance Assessment**

Ask students: If you were a mass (or positive/negative charge, or a magnet), describe how you would react to being:

- near the Earth (remember  $B_{\text{earth}}$ )
- near a positive charge (which may or may not be moving)
- near a negative charge
- sandwiched between two plates
- near one pole of a magnet
- between two poles of a magnet
- inside a solenoid

**SUGGESTED LEARNING RESOURCES**

Herreman, W. and R. Huysentruyt. (1995) "Measuring the Magnetic Force on a Current Carrying Conductor." *The Physics Teacher* 33.5: 288.



## NOTES



---

# ***APPENDICES***

Appendix 1: Waves

Appendix 2: The Nature of Light

Appendix 3: Mechanics

Appendix 4: Fields

Appendix 5: Developing Assessment Rubrics in Science

Appendix 6: Assessment Rubrics

Appendix 7: General Learning Outcomes

---

## APPENDIX 1: WAVES

**BLM**

 Blackline  
Master

### Appendix 1.1: Strobe Template

The hand stroboscope can be used to determine the frequency of an object with repetitious motion. By rotating the stroboscope and looking through the open slits, the experimenter can make the object appear at the same position at all times. This gives the illusion that the object is stopped. Experiment to determine the combination of open slits and frequency of the stroboscope required to “stop” the object. The number of slits can easily be changed by taping every second slit.

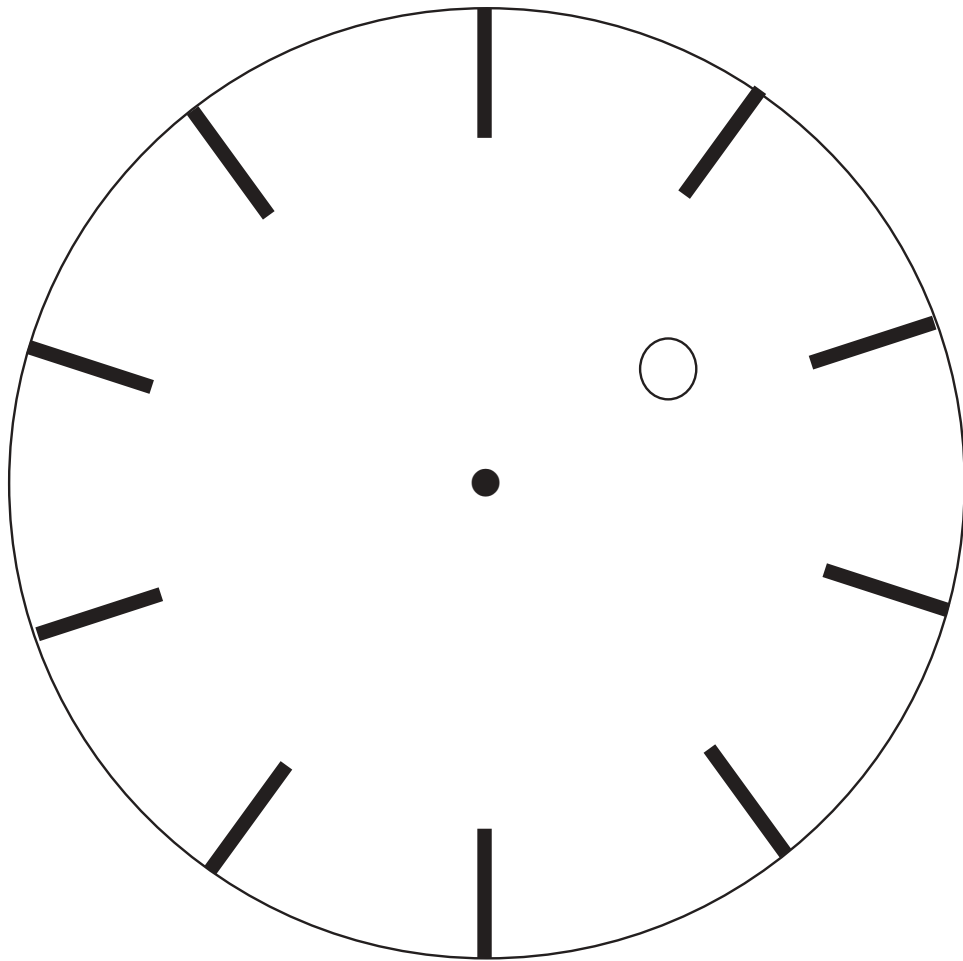

#### Strobe Student Activity

Calculate the frequency of a vibrating object using:

Frequency of object = stroboscope frequency x number of open slits





### Appendix 1.2: Concept Map for Wave Equation Variables

**Concept Map:** Students will identify variables for the universal wave equation and see how they are related. (Specific Learning Outcome 1.1.4.)

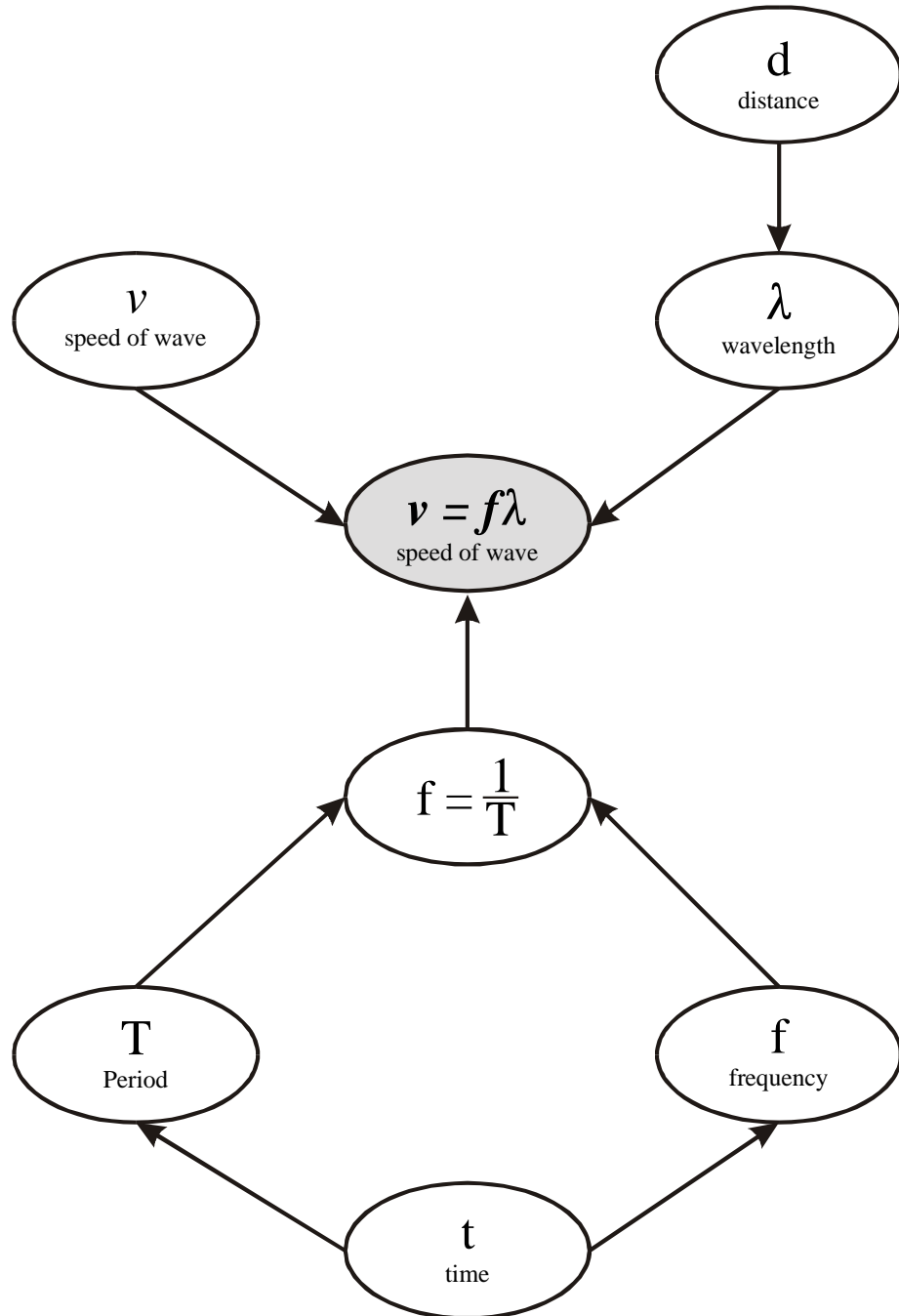



**SLA**  
Student  
Learning  
Activity

### Appendix 1.3: Superposition of Waves

1. Draw the superimposed pulse when point A coincides with point B.

**Note:** You must draw in point A and point B on each diagram.

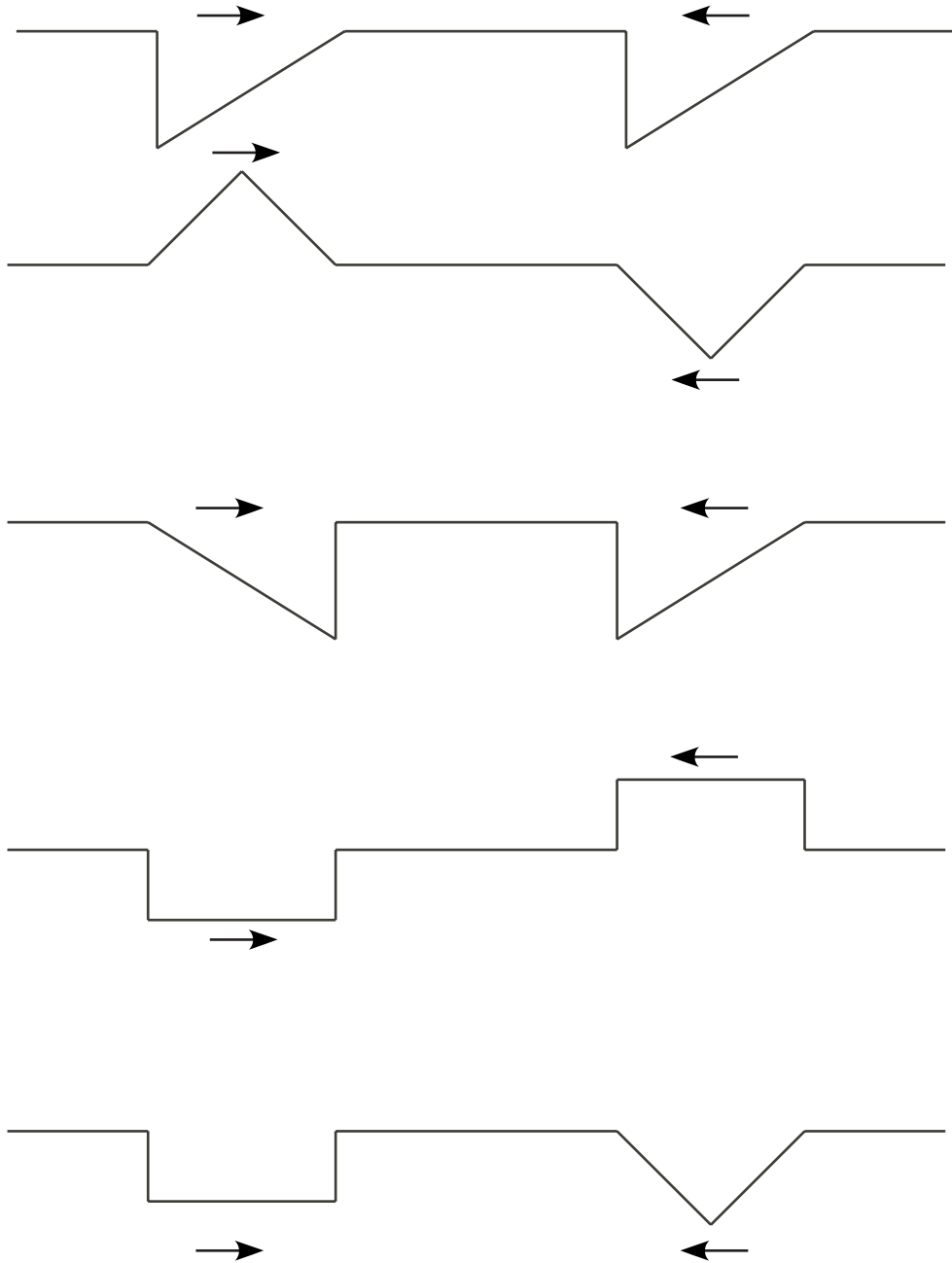

2. Draw a pulse moving to the left that would momentarily cancel the given pulse when they meet.



3. Draw a pulse moving to the left that would pass through the given pulse without the midpoint, M, moving.

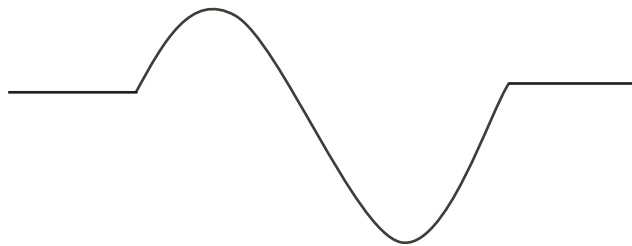

4. Draw in the resultant wave.

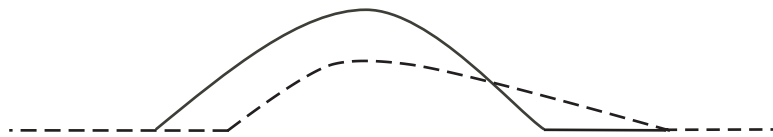



## Appendix 1.4: Waves in One Dimension

1. Define the following terms:

a) wavelength

b) amplitude

c) transverse wave

d) frequency

e) node

f) rarefaction

2. What is a wave?



3. Draw in the resultant wave.

a)

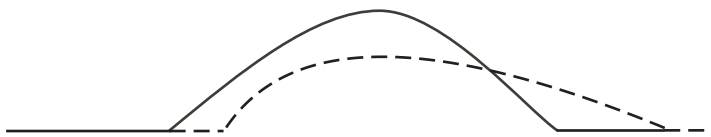

b)

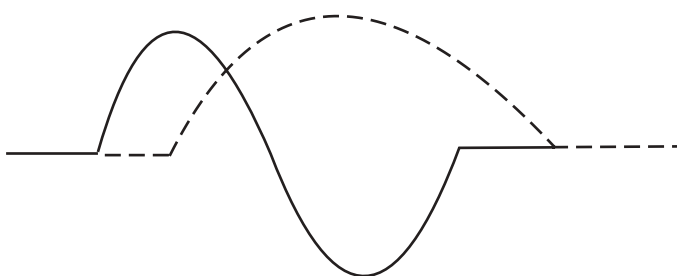

4. Using diagrams, indicate what occurs if a wave travelling on a spring meets each of the following junctions. Include a description of each transmitted pulse and each reflected pulse.

a) a fixed end

b) a junction between a heavy and a light spring

c) a junction between a light and a heavy spring



5. Draw a wave pulse moving to the left that will momentarily cancel the given pulse.

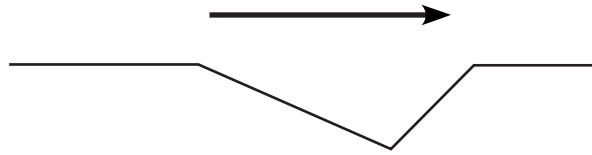

6. Draw in the wave pulse moving to the right that will pass through the given pulse without causing M, the midpoint, to move.

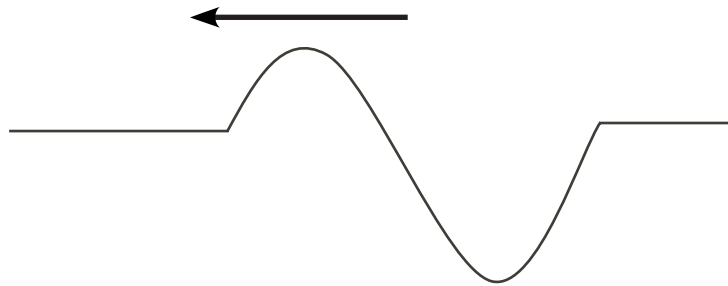

7. The picture below shows a segment of a string along which a transverse wave is moving.



Based on this picture, what is

- the wavelength of this wave?
  - the amplitude of this wave?
  - the frequency of the wave if it took 0.28 s for the given waves to pass by a point?
8. What is the speed of a wave with a wavelength of 0.27 metres and a frequency of 7.5 Hz?
9. A transverse wave is moving along a string. What is the period of this wave if it has a wavelength of 0.45 metres and a propagation speed of 22 m/s?
10. A woman is fishing from a stationary rowboat in the middle of a lake. A speedboat starting up 7.5 metres away from the rowboat sends out waves with a speed of 0.85 m/s and a frequency of 0.95 Hz.
- What is the wavelength of these waves?
  - How many wavelengths would fit into the distance between the speedboat and the rowboat?



**BLM**

Blackline  
Master

**Appendix 1.5: Derivation of Snell's Law**

The diagram represents the incident and refracted wavefronts and wave rays. As the wavefront passes from the fast ("lighter") medium to the slow ("heavier") medium, the wavefront slows down and bends.

Consider the wavefronts.

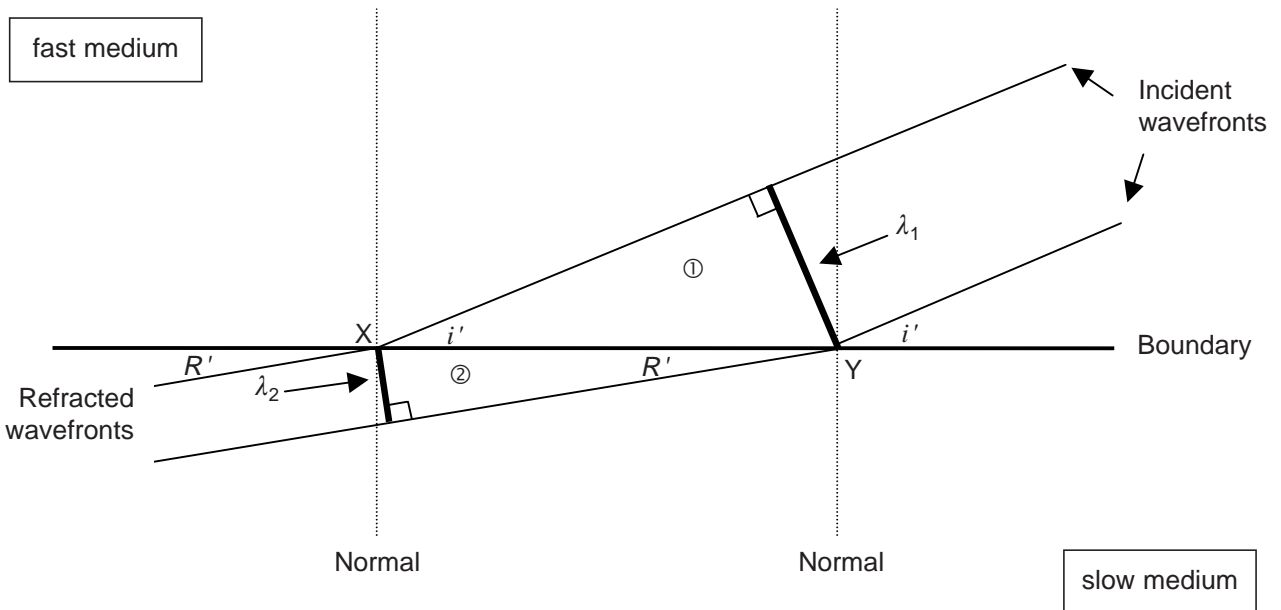
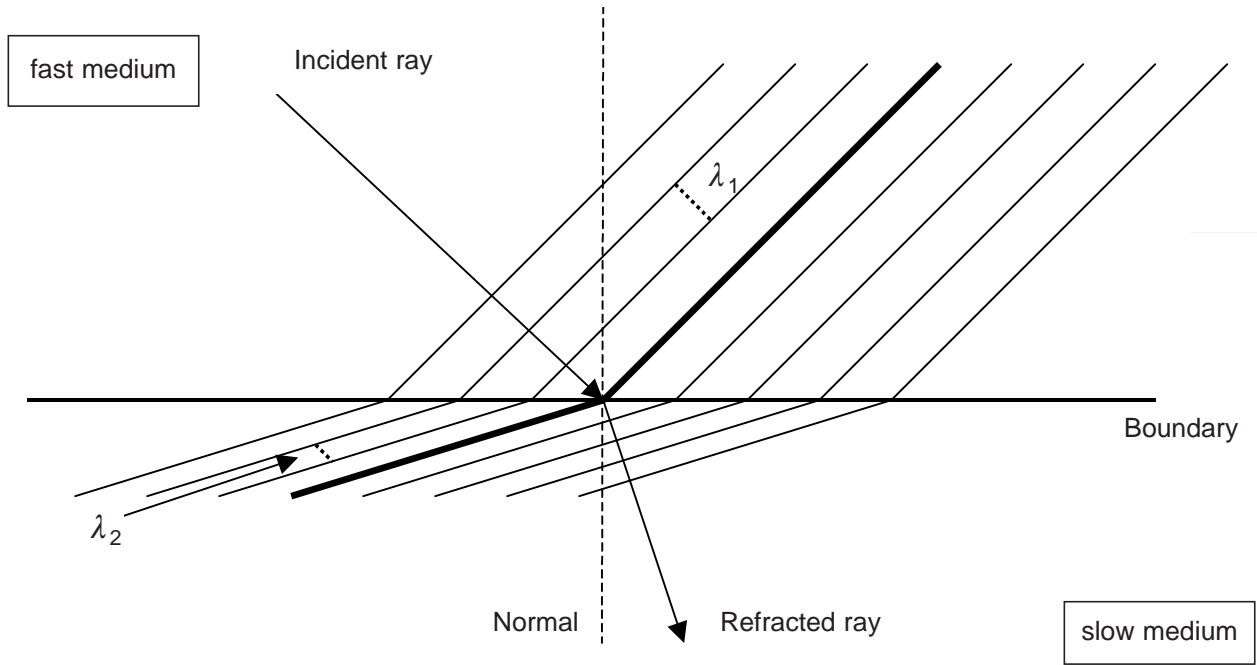

1. In triangle 1:  $\sin i' = \frac{\lambda_1}{XY}$

4. Therefore:  $\frac{\sin i'}{\sin R'} = \frac{\lambda_1}{\lambda_2}$

2. In triangle 2:  $\sin R' = \frac{\lambda_2}{XY}$

5. Since  $v \propto \lambda$ , then  $\frac{v_1}{v_2} = \frac{\lambda_1}{\lambda_2}$

3. Solve for  $\overline{XY} = \frac{\lambda_1}{\sin i'} = \frac{\lambda_2}{\sin R'}$

6. Therefore:  $\frac{\sin i'}{\sin R'} = \frac{v_1}{v_2}$

In terms of the wave ray:

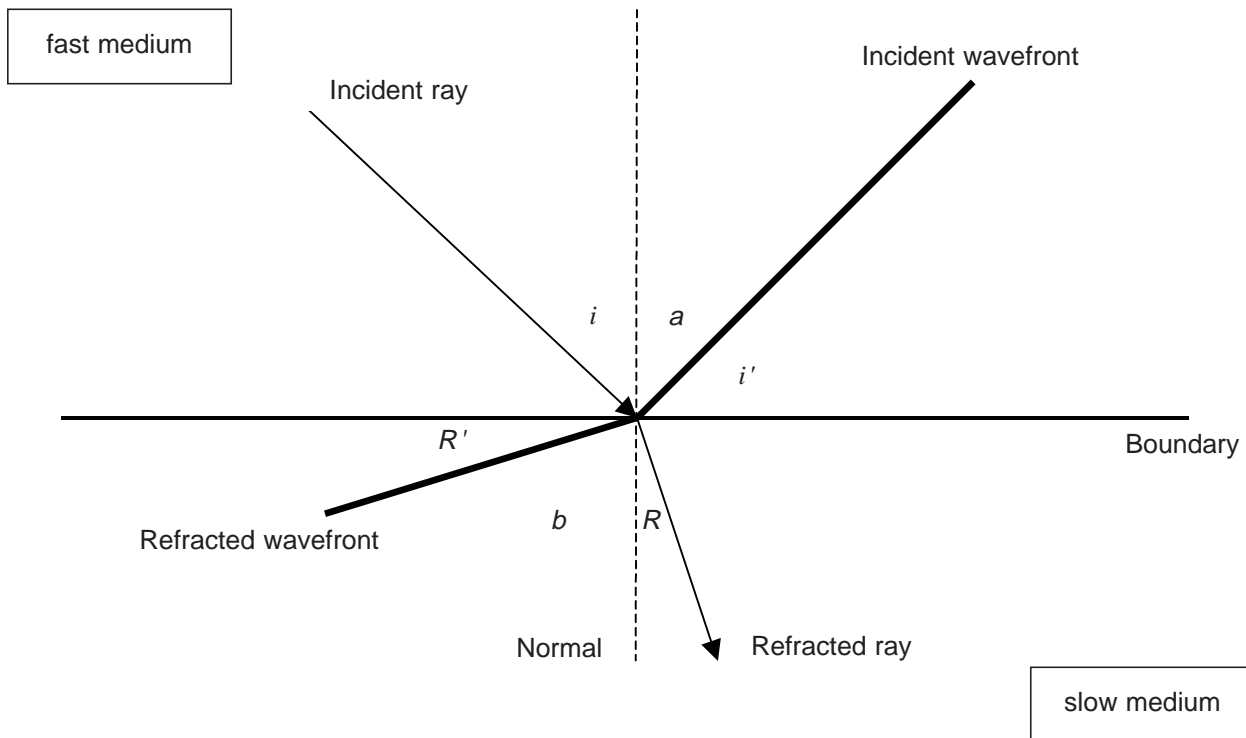

Since the wave ray and wavefronts are perpendicular:  $i + a = 90^\circ$ .

Since the normal and boundary are perpendicular:  $a + i' = 90^\circ$ .

Therefore,  $i + a = a + i'$ .

And:  $i = i'$ .

Similarly,  $R = R'$ .

Snell's Law states that the ratio of the sines of the incident and refracted angles are constant.

$$\frac{\sin i}{\sin R} = {}_1n_2 \text{ where } {}_1n_2 \text{ is called the index of refraction.}$$





**Working with Snell's Law and Wavefronts**

1. Draw in the reflected wave ray. Indicate clearly the direction of motion, the angle of incidence, and the angle of reflection.

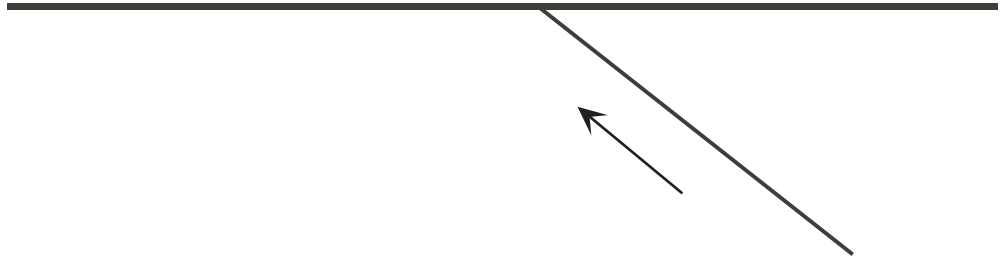

2. The diagram below represents a ripple tank with deep and shallow water. Waves in deep water travel up the page towards the boundary with shallow water, as illustrated below. The frequency of the wave is 8.50 Hz. In deep water, the waves travel at 9.0 cm/s. Diagram is drawn to scale.

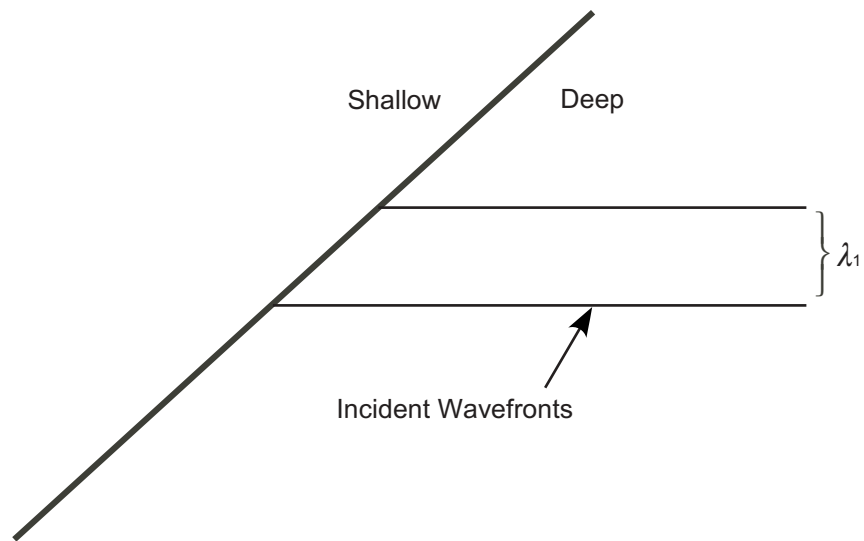

- a) Draw in the **direction of motion** and the **angle of incidence**.
- b) Determine the **relative index of refraction** at the shallow-deep surface.
- c) Determine the **angle of refraction** in deep water.
- d) Draw in the two **refracted** wave crests in the deep water.



**BLM**

Blackline  
Master

## Appendix 1.6: Circular Wave Patterns

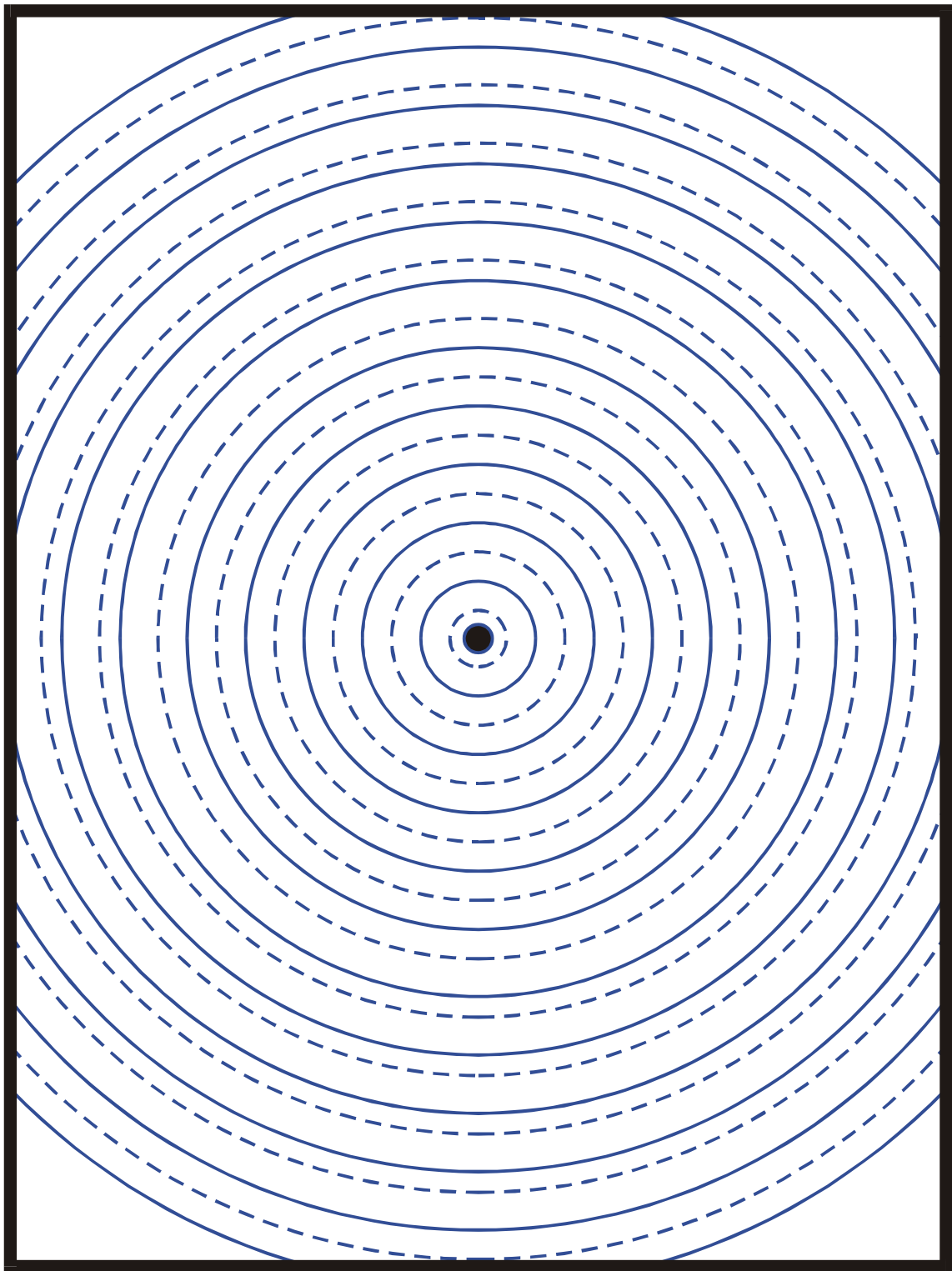

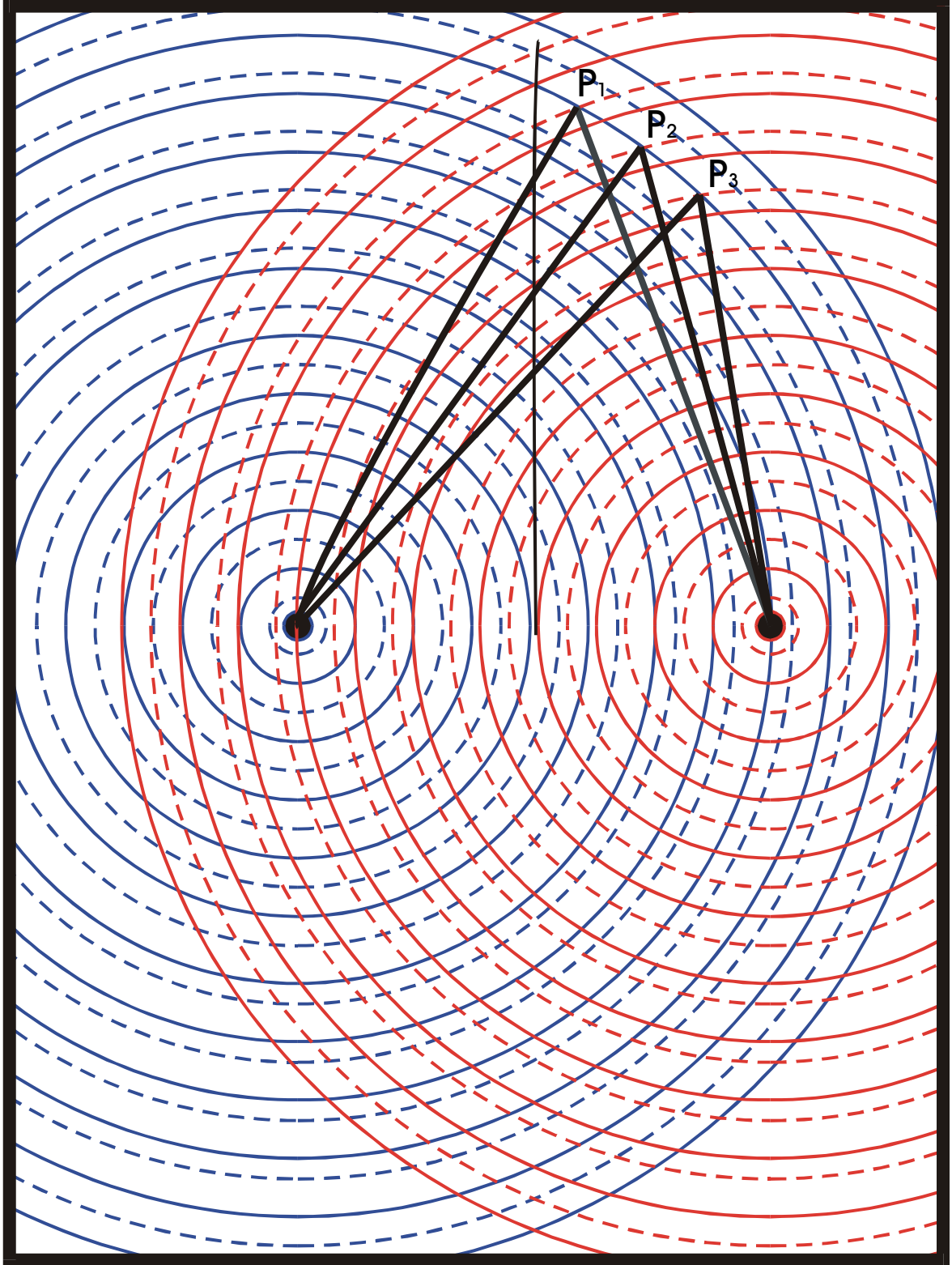

**BLM**

Blackline  
Master

### Appendix 1.7: Interference Pattern from Two Point Sources

From the diagram, represent the path difference in terms of the wavelength.

That is, show  $|\overline{P_n S_1} - \overline{P_n S_2}| = (n - \frac{1}{2})\lambda$ , where P is a point on the nodal line and  $S_1$  and  $S_2$  are the sources.

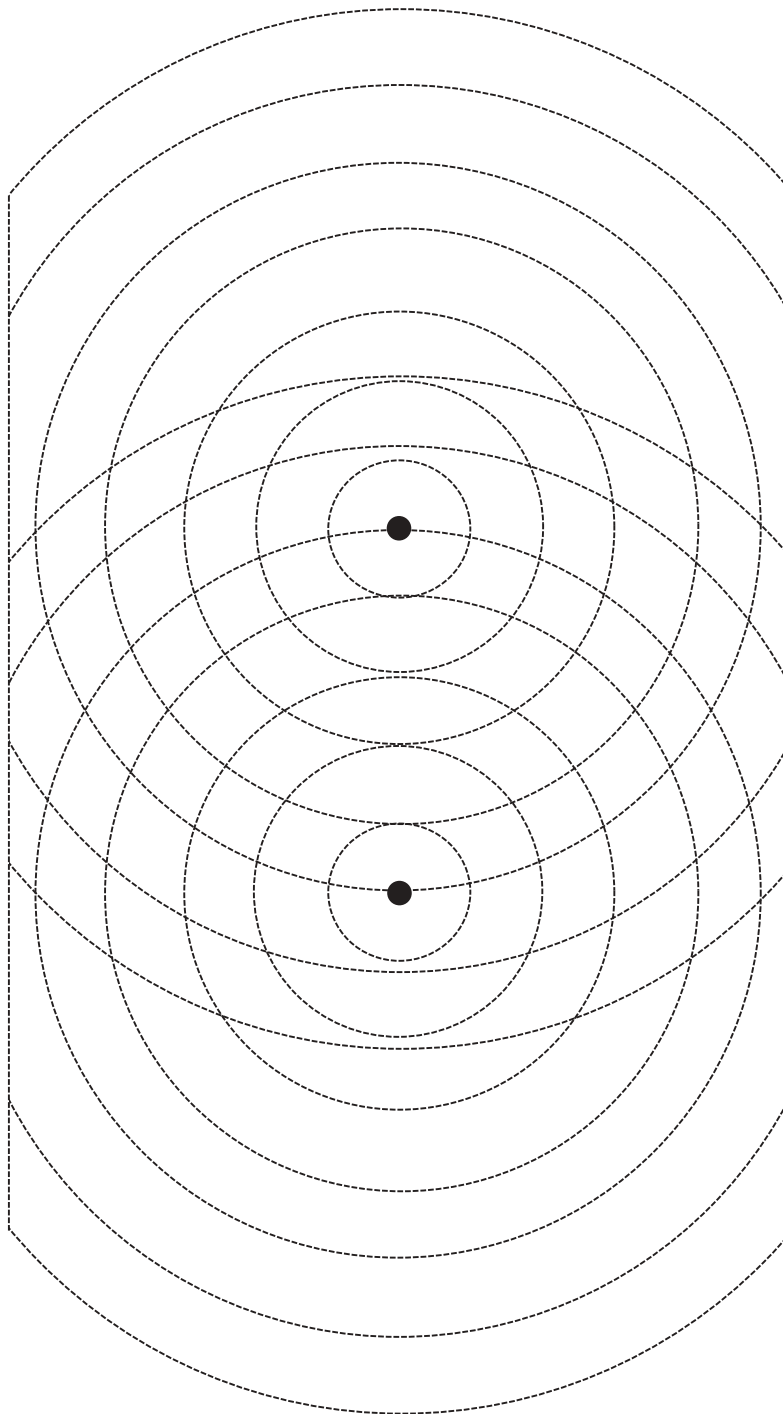

**BLM**

Blackline  
Master

## Appendix 1.8: Moiré Patterns

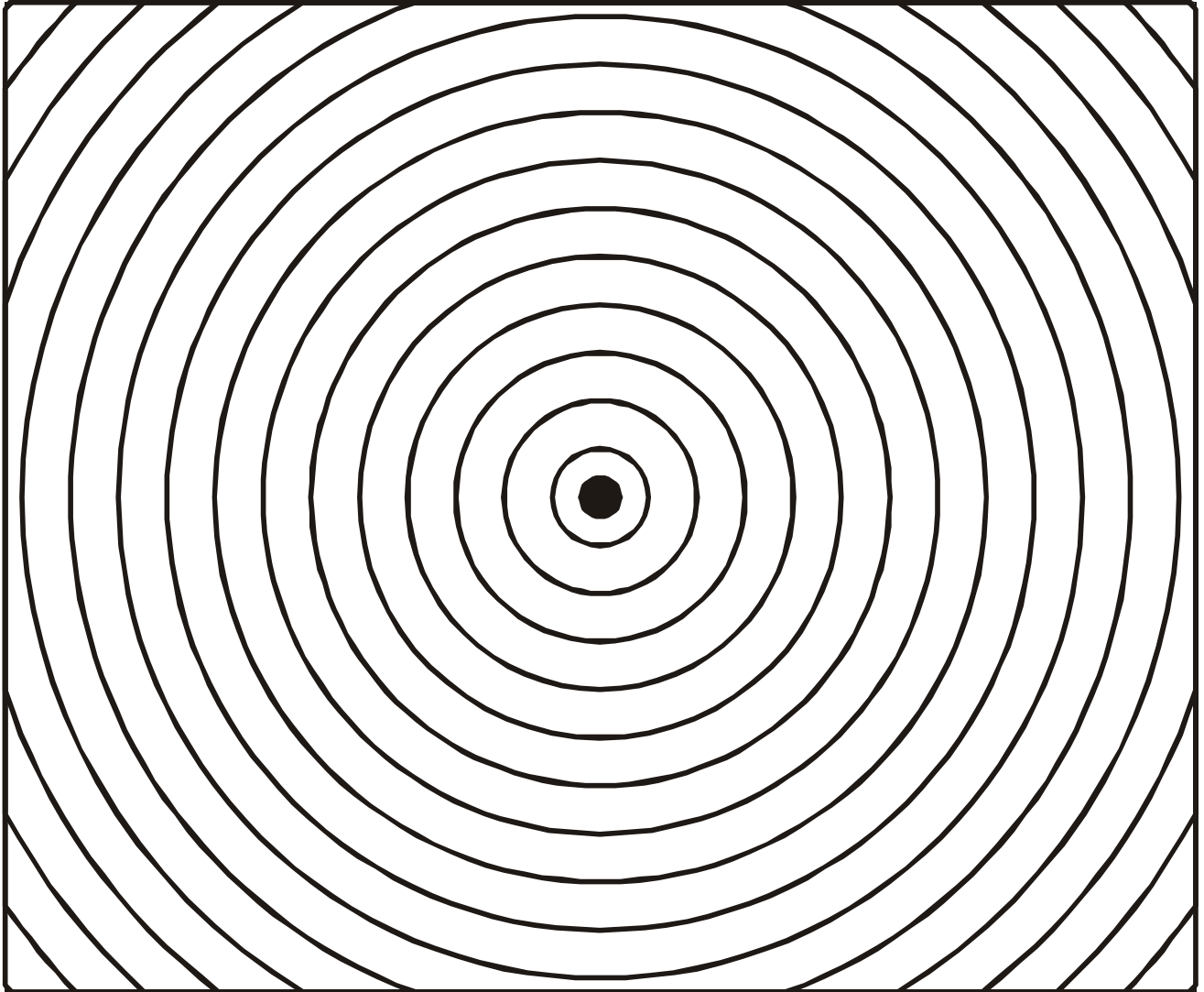

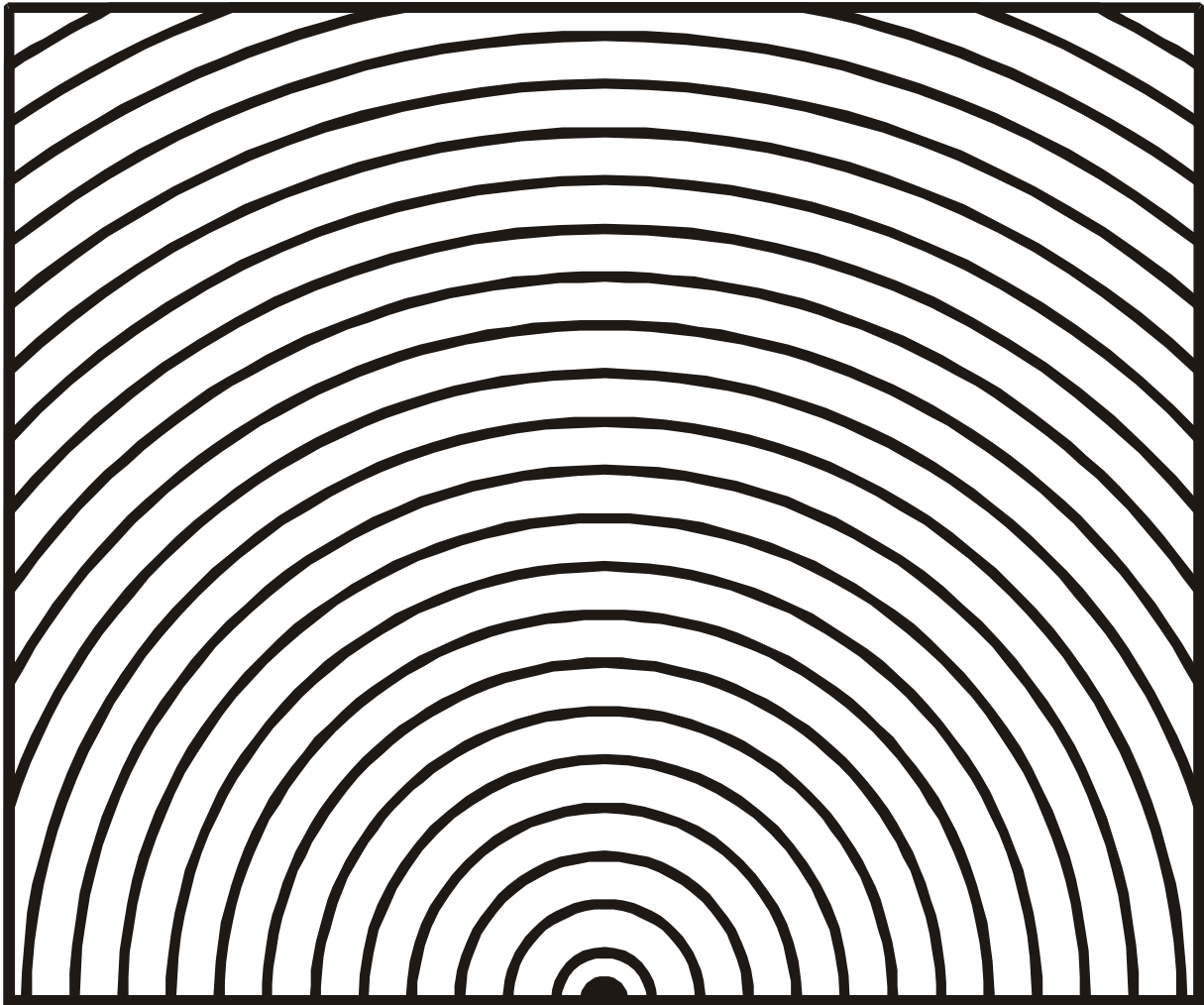

**BLM**Blackline  
Master**Appendix 1.9: Data Table for Speed of Sound**

Speed of Sound	
Material	Speed (m/s)
Gases at atmosphere pressure, 0°C	
Hydrogen	1270
Air	332
Oxygen	317
Carbon dioxide	258
Liquids	
Fresh water (250°C)	1493
Alcohol	1241
Solids (at 0°C)	
Aluminum	5104
Glass	5050
Steel	5050
Human bone	4040
Pine wood	3320



**BLM**

Blackline  
Master

### Appendix 1.10: Sound Intensity Levels Table

Sound Intensity Levels (dB)	
Threshold of hearing	0
Normal breathing	10
Whisper	20
Two-person conversation	60
Vacuum cleaner	80
Air chisel	110
Rock concert	120
Jet taking off	140





## APPENDIX 2: THE NATURE OF LIGHT

### Appendix 2.1: Wave-Particle Model of Light—Models, Laws, and Theories

Science is more than just a collection of facts and observations. Models, laws, theories, and evidence all play an important role in understanding the nature of science. A scientific model is a conceptual representation (idea in your head) that stands for, and helps explain, other things. A model can be physical (a real thing), imagined (in my brain!), or mathematical (numbers and formulas). In science, we develop models that have explanatory and predictive powers (like the model of the universe) and we test these models in the world around us. If our model predicts our observations, we accept the model as a valid description of our world. However, if our model encounters discrepant events and fails to provide adequate explanations, we begin to modify our model or search for an entirely different model.

A good example of a scientific model is the model of the solar system. At one time it was thought that the Sun revolved around the Earth and this geocentric model of the universe was considered to be a “true” representation for many centuries. The model encountered a discrepant event when the retrograde motion of the planets did not exactly fit the epicycles of the geocentric model. A new model, the Copernican Sun-centred model, provided a simple explanation of the movement of the planets and it predicted the phases on Venus. Years later, the invention of the telescope permitted more sophisticated observations to confirm the predictions of the Sun-centred model.

Observations can be used to test models, both externally or by thought experiments, as we re-think and apply our model to new and sometimes discrepant situations. Our observations can lead us to identify regularities and patterns in nature. We call these regularities and patterns **scientific laws**. For example, a simple scientific law would be “what goes up must come down.” We can also deduce laws, given a certain set of conditions. For example, if light is a wave, we can geometrically show that the ratio of the sines of the angles of incidence and refraction is a constant. We often represent laws as mathematical relationships (e.g., Snell’s law, Ohm’s law, Charles’ law, or Newton’s laws). Contrary to popular belief, laws are not absolute but are often constrained to certain conditions. Ohm’s law is valid only for some materials and our pressure laws are constrained by temperature. Even Newton’s laws are valid only in inertial frames of reference.

Scientific theories form explanatory systems for phenomena (and their corresponding laws) and may include presuppositions, models, facts, and laws. For example, Einstein’s theories presuppose that the speed of light is constant in all frames of reference. In Einstein’s world, Newton’s laws, such as  $F = ma$ , hold only for objects that are moving much more slowly than the speed of light.



We must be very careful how we use the term “theory.” In everyday usage, the word theory often refers to an idea that is not proven. It’s partially true that some theories, like many cosmological theories, are speculative ideas and are based on little evidence. Additionally, children often hold simple or naive theories about why things float or why the sky is blue. Hypotheses, or proposed solutions, are also often speculative and we often seek to build support for them through predictions and observations. However, other theories, like theories of radiation, metabolism, or chemical bonding, have considerable evidential supports. It is impossible to “prove” our theories for every possible case, but robust theories explain a great deal and we sometimes literally “bet our lives” on them. Therefore, scientific theories lie along a spectrum from speculative hypotheses to robust explanatory systems. In science education, we often use early models or theories that are adequate for a less sophisticated understanding of a scientific concept. For example, Bohr’s model of the atom explains all the phenomena one might examine in an introductory chemistry program. More progressive theories require a more extensive background.

While it is important that our understanding of the nature of science is embedded in the context that the world is rational and can be understood, we never really know if we have achieved the most rational explanation. In science, truth is elusive but our beliefs must extend far beyond individual opinions. In science, we insist on an evidential argument.

### The Theory-Evidence Connection

One of the main questions scientists are concerned with is the relationship between theory and evidence. It is not unusual in science education to make a knowledge claim in the form of “I know that...”. For example, while discussing health with your doctor, she might say that “lowering cholesterol level lowers one’s risk of heart disease.” To further the claim, support is found for that knowledge claim. We will call this support *evidence*. The nature of the evidence presented will depend on the background knowledge of the knowledge claimer (in this case a doctor). For example, she might stress the statistical evidence or discuss the latest hypotheses of the underlying mechanism that relates cholesterol level and platelet formation. Of course, one might simply quote a recognized authority, like the Department of Health, and not attempt to formulate an argument at all.

Since the background knowledge of the claimer and the intended audience may be different, an evidential argument must be given that “makes sense” to the audience and connects with their prior knowledge and experience.

Consequently, a selection process (theory choice) is involved in deciding the adequacy of a given theory in terms of its ability to accommodate the available evidence. This selection process reviews and judges the characteristics of a good scientific theory. A good theory is accurate; the predictions the theory makes closely match the observations made to support the theory. However, accuracy is not the only characteristic of a good theory. When two theories are equally accurate, the better theory is often the simpler explanation. The Copernican



model of the solar system was no more accurate than the Ptolemaic model, with a series of epicycles to account for the motion of the planets. In the face of equally accurate models, Copernicus' theory simplified the model of the solar system tremendously. Furthermore, a good scientific theory has explanatory powers that cover a broad scope. It explains a lot, even phenomena it was not intended to explain. The scope of a good theory also extends to bold predictions. Often these predictions, such as Einstein's prediction that light would bend near large bodies, are not confirmed until years later.

### **Implications for Science Teaching**

In science education, teachers find that students are frequently "turned off" by science. This is not surprising when one considers that they are routinely asked to perform tasks on the basis of a theoretical model that is not connected to an evidential-experiential base that "makes sense." Solving problems based on a memorization of Ohm's law, or memorizing the valences of elements in order to balance chemical equations, are good examples of such tasks. Students should be encouraged to address such questions as "What are reasons to believe?" and "What is the evidence for?"



**SLA**Student  
Learning  
Activity

## Appendix 2.2: The Mystery Container

The mystery container, sometimes called the black box, is an excellent activity for introducing the nature of science concepts for models, laws, and theories. Students' observations come from their sense data, but they must put meaning to these observations by inferring a model to explain the underlying mechanism of the mystery container. Regularities can be identified as simple laws, and a theory can be advanced that includes observations, inferences, a model, and laws to provide an explanatory system for the mystery container.

Mystery containers are easy to make but you might want to follow a few simple rules.

- No more than two distracters should be placed inside the box.
- Nature does not reveal the atom to us. We must still count on indirect evidence and our inferences to develop an adequate explanatory system. Therefore, the containers should be sealed (or the contents destroyed as in the IPS black box activity).

Diagram of a sample mystery container:

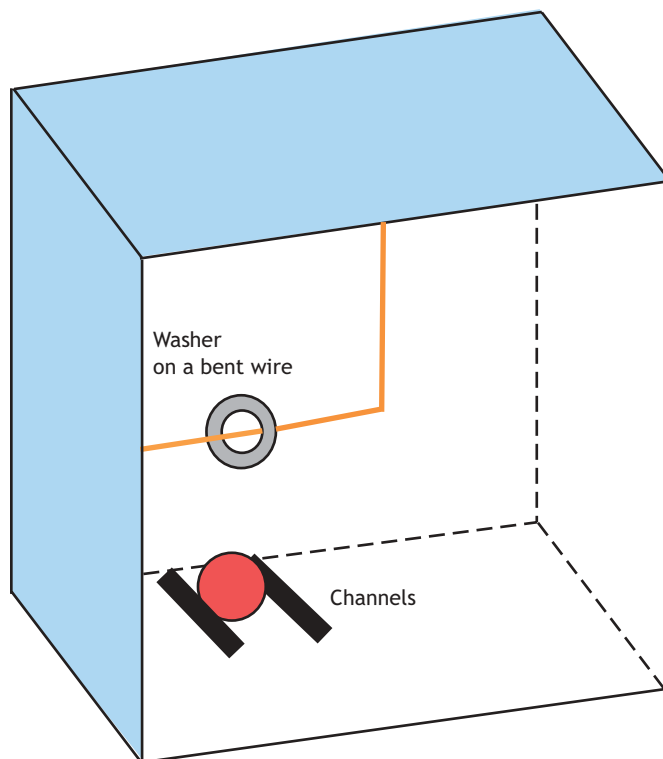

Examine, but do not open, your mystery container.

1. Carefully record your observations and make some inferences about the contents of your container.
2. Make a diagram of the contents of your container.
3. Make a list of the regularities and patterns that you find during your investigation.

Observations	Inferences
<b>Regularities and Patterns</b>	
<b>Diagram of Contents</b>	

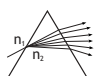



### Appendix 2.3: Astronomy with a Stick

Apparatus: Five sticks of different lengths (e.g., 0.2 m, 0.4 m, 0.6 m, 0.8 m, and 1.0).

A metre stick or measuring tape.

A sunny day! (**Note:** Never look at the Sun directly!)

In this experiment, you must collect your data quickly (in less than 10 minutes).

1. Place the stick on the ground outside and measure the length of its shadow.
2. Graph the height of the stick versus the length of its shadow.

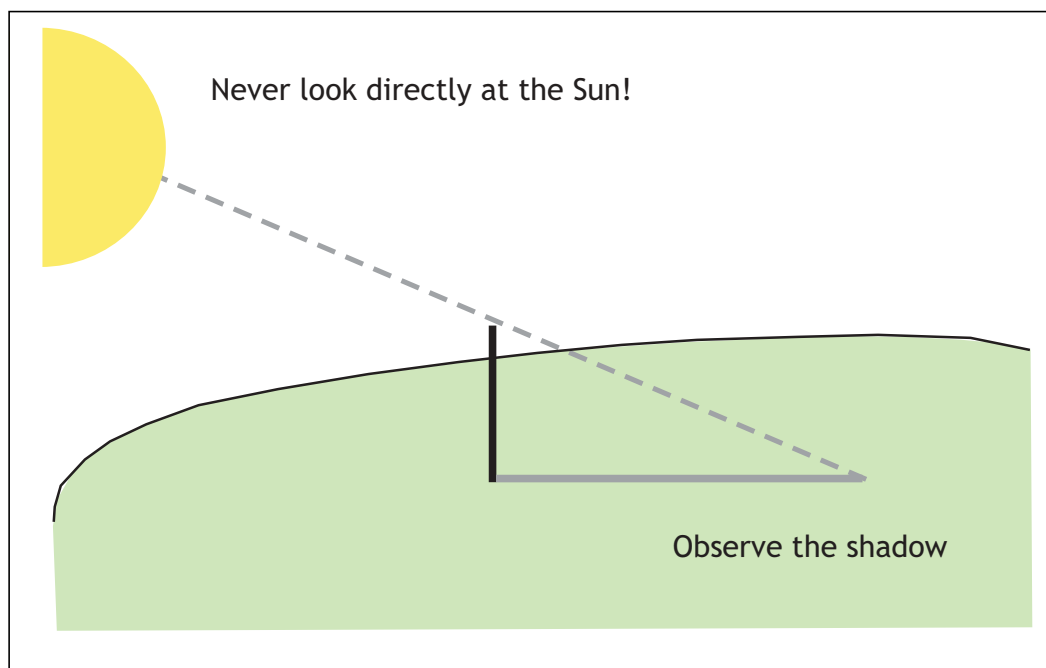

#### Nature of Science Questions

1. Can you describe a simple law that relates the height of the stick to the length of its shadow?
2. State a mathematical law that relates the height of the stick to the length of its shadow.
3. What does “the slope of the height versus length graph” mean?
4. Compare your results with data that are collected over a long period of time (such as an hour).
5. Are there any constraints to your mathematical law?
6. Will your mathematical law be the same tomorrow? Next year?



**BLM**

Blackline  
Master

**Appendix 2.4: Chart for Evaluating the Models of Light**

Model \_\_\_\_\_

Accuracy?  
Explanatory Power?  
Simplicity?

Phenomena	Supporting Arguments	Counter-Arguments
Rectilinear Propagation		
Reflection		
Refraction		
Dispersion		
Diffraction		
Partial Reflection/ Refraction		
Speed of Light		





## Appendix 2.5: Jupiter and Its Moon Io

### Watching Io as It Passes into Jupiter's Shadow (Umbra)

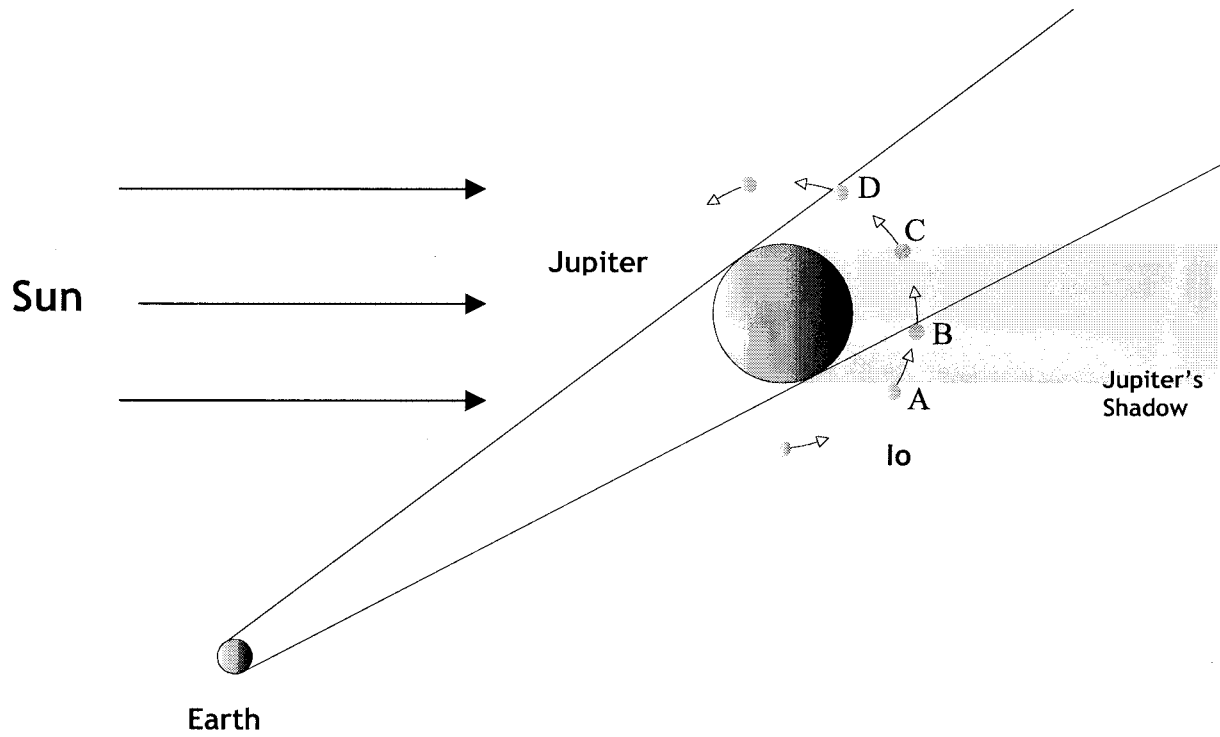



**BLM**Blackline  
Master

## Appendix 2.6: Ole Christensen Rømer: The First Determination of the Finite Nature of the Speed of Light

### A Rømer Timeline...

#### 1. Dates

*Born:* Aarhus, Denmark, 25 Sept 1644

*Died:* Copenhagen, 19 Sept 1710

*Dateinfo:* Dates Certain

*Lifespan:* 66

#### 2. Father

Christen Pedersen Rømer

*Occupation:* Merchant

It is known that when he died (1663 at the latest) he left Ole a great many navigational instruments and books; it appears then that he must have been, at the least, fairly wealthy.

#### 3. Nationality

*Birth:* Aarhus, Denmark

*Career:* Copenhagen, Denmark, and France

*Death:* Copenhagen, Denmark

#### 4. Education

*Schooling:* Copenhagen

In 1662, he was sent to the University of Copenhagen, where he studied with Thomas and Erasmus Bartholin.

#### 5. Religion

*Affiliation:* Lutheran

#### 6. Scientific Disciplines

*Primary:* Astronomy, Optics

*Subordinate:* Physics

#### 7. Means of Support

*Primary:* Academia, Government, Patronage

He lived and studied with Erasmus Bartholin, who was impressed enough with his work to entrust to him the editing of Tycho Brahe's manuscripts. From 1664 to 1670, he edited Tycho's manuscripts.

In 1671, he accompanied Bartholin and Jean Picard to Hveen to observe the position of Tycho's observatory. Then, in 1672, he accompanied Picard back to Paris where he was assigned lodgings in the Royal Observatory and worked under the auspices of the Académie. It is generally assumed that he was a member of the Académie. Louis XIV appointed him to tutor the Dauphin in astronomy, and Rømer travelled around France, making observations at the behest of the Académie.

In 1677, the Professorship of Astronomy in Copenhagen was designated for him.



In 1681, he became Professor of Mathematics at the University of Copenhagen. He was also appointed Astronomer Royal and director of the observatory. In addition, he served in a number of advisory roles to the king, as master of the mint, harbour surveyor, inspector of naval architecture, ballistics expert, and head of a highway commission.

In 1688, he became a member of the privy council.

In 1693, he became the judiciary magistrate of Copenhagen.

In 1694, he became chief tax assessor.

In 1705, he became mayor of Copenhagen. Later, he became prefect of police.

In 1705, he was named a senator.

In 1706, he was named head of the state council of the realm.

## 8. Patronage

*Types:* Scientist, Court Official

The first part of his life, he was supported by scientists: first Bartholin, then Picard, who remained his patron after he settled in Paris. Some connection through the Académie probably allowed him to be appointed as Louis XIV's tutor. In 1704, long after his return to Denmark, he built his observatory on land owned by Erasmus Bartholin.

The major patron in his life was Christian V of Denmark, who appointed him as Astronomer Royal and was responsible for the numerous appointments he held.

After Christian V died, Frederick IV assumed his patronage, first giving Rømer an appointment in 1705.

## 9. Technological Involvement

*Types:* Instruments, Civil Engineering, Hydraulics, Cartography

In Paris, part of his duties involved making instruments. He built clocks and other devices, including a micrometer for differential measurement of position. In Copenhagen, as director of the observatory, he continued his innovation in instrumentation. He was perhaps the first to attach a telescopic sight to a meridian transit.

He also invented a new thermometer and was active in the science of thermometry, passing some ideas to Gabriel Fahrenheit, whom he met in 1708.

Rømer reordered Denmark's system of measuring and registration and introduced a new, rational system for numbers and weights. The number and weight reforms were especially important because the previous system was confusing and hampered trade. Rømer combined weight and length, a system that only occurred in other lands more than a century later (with the metric system).



While Copenhagen was growing rapidly in these years, Rømer was in charge of laying out streets, lighting, water supply and drainage, fire standards, and lesser affairs.

In 1699, he revised the calendar, so that Easter was scheduled according to the Moon.

## 10. Scientific Societies

*Memberships:* Académie Royale, Berlin Academy

He corresponded with Leibniz, Fahrenheit, and others.

Hofer and Leksikon indicate he became a member of the Académie in the early 1670s, but the verbal records of the Académie for this period are missing and this piece of information is not generally mentioned in secondary sources.

Honourary member of the Berlin Academy.

## Sources

1. Hofer, "Rømer," *Nouvelle biographie universelle*, 42 (Paris, 1862), cols. 495-7. [ref. CT143.H6]
2. I.B. Cohen, *Rømer and the First Determination of the Velocity of Light* (New York, 1944). [QC407.C67]
3. Rene Taton, *Rømer et la vitesse de la lumière* (Paris, 1978). [QC407.R63]
4. Kirstine Meyer, "Rømer" [in Danish], *Dansk Biografisk Leksikon*, 20 (Copenhagen, 1941), 392-400. [CT1263.D2]

---

**Rømer, Ole Christensen:** Compiled by Richard S. Westfall, Department of History and Philosophy of Science, Indiana University. Reproduced from <http://es.rice.edu/ES/humsoc/Galileo/Catalog/Files/roemer.html>. Reprinted with permission. All commercial rights reserved.



# SLA

Student Learning Activity

## Appendix 2.7: Ole Rømer and the Determination of the Speed of Light

Natural philosophers have demonstrated an interest in the nature of light since the time of the Greeks. Fundamentally, the nature of light was linked to our understanding and explanations of vision. Early theories of light (or vision) maintained that light emanated from the eyes and its propagation was instantaneous. Hero of Alexandria claimed that the speed of light was instantaneous, noting that if you keep your eyes closed, look to the stars, and then suddenly open your eyes, you will see the stars. Since no time elapses between the opening of your eyes and the sight of the stars, then the speed of light must be instantaneous.

In the 17th century, mapmaking and navigation inspired a great search for the determination of longitude. Galileo discovered the four largest moons of Jupiter in 1610, and immediately recognized that the regularity of the period of these moons could easily be used as a "clock." The orbital period of a moon of Jupiter can be calculated by observing the successive eclipses of the moon. The diagram below illustrates the geometry of observing an eclipse of the moon Io. An eclipse begins when Io enters the shadow of Jupiter (point A).

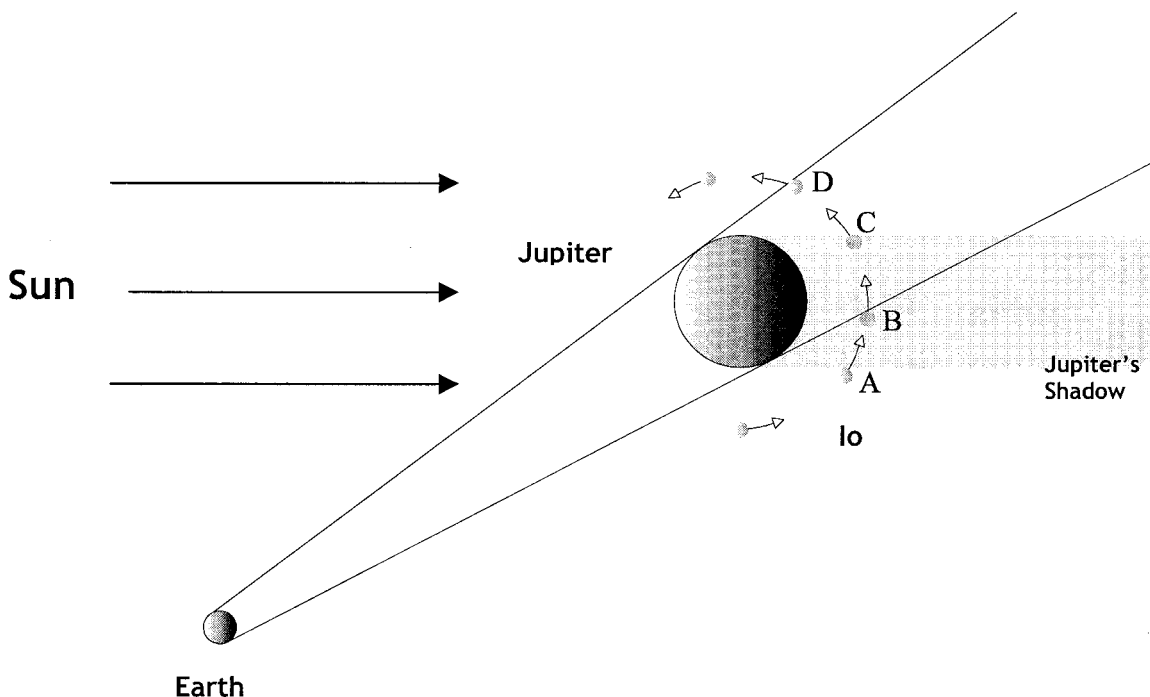

### Questions:

1. When the Earth is in this position, can we observe when the eclipse begins? ends?
2. Describe how you would start and stop a clock to measure the orbital period of Io.
3. Draw a diagram of Jupiter and Io, making the disk of Jupiter about 3 cm across, showing where Io would be when an observer no longer sees it in a telescope.



## Using *Starry Night* Software to Calculate the Period of Io

*Starry Night* is a planetarium program that you can download and demo at <http://www.space.com>. It is available through the Manitoba Text Book Bureau (stock #MS 8420).

During the period 1668–1678, Ole Rømer timed eclipses of Io over 50 times. Not all the observations were true eclipses, however, with Io passing into Jupiter’s shadow behind the planet. Occasionally, Rømer was timing what is called a **transit**, where the moon Io actually passed in **front** of Jupiter as seen from Earth.

Some of the early observations from the period 1668–1672 took place at Tycho Brahe’s famous Uraniborg (“city of the Heavens”) observatory near Copenhagen, Denmark, and were done in partnership with the astronomers Jean Picard and Giovanni Domenico Cassini of France. Over the period 1672–1678, observations were made from the Paris Observatory. For some of Rømer’s observations, Earth was moving towards Jupiter. However, for the majority of the eclipses of Io, Earth was moving away from Jupiter. This was likely done to accommodate observing Jupiter during “prime time” in the hours from sunset to midnight when Jupiter was an easy-to-see object in the evening sky. The table on page 53 of Appendix 2.10 shows the timings of these eclipses of Io as recorded in Ole Rømer’s handwritten notes. Note the times of his observations, and see his preference for “prime time” observing after sunset.

### The Orbital Period of Io

Calculate the average value of the orbital period of Io for each set of values when the Earth is moving towards Jupiter and when the Earth is moving away from Jupiter. Compare these values.

Rømer found that the orbital period of Io was always slightly longer when the Earth was moving away from Jupiter compared to when the Earth was moving toward Jupiter. Rømer concluded that the speed of light was the reason for this discrepancy of time. The drawing of Rømer’s observation on page 37 of this appendix shows the Earth-Jupiter system that he may have used to calculate the speed of light.

We know:

$$\text{speed} = \frac{\text{distance}}{\text{time}} = \frac{\Delta d}{\Delta t}$$

Therefore, the speed of light will be the extra distance that light travels divided by the time that has elapsed over that distance. We calculate this twice: when Earth is moving away from Jupiter, and when Earth is moving towards Jupiter, and then we compare our data. For a first approximation, we assume that Jupiter does not move at all over such a short period of days to weeks, and motions of Earth and Jupiter occur in the same plane.



1. Find the date for a Jupiter-Earth opposition. For example, on February 3, 2003 @ 00h UT (Universal Time).
2. Convert this date to the Julian Date (2452673.50000). The Julian Date (JD) is the number of days since noon on January 1, 4713 BCE, according to the Julian calendar. By clicking on the arrowhead icon to the right of the UT symbol in the time window, *Starry Night* will make this conversion for you.

**Note:** From this point forward, all Julian Dates in brackets (e.g., 2452673.5) represent possible answers for each step in our procedure.

3. Using the *Starry Night* "outer solar system" view (GO→SOLAR SYSTEM→OUTER SOLAR SYSTEM), zoom in until you can see both Jupiter and Earth on the same screen. You will have to click on the "Find" tab and toggle "on" the orbit of Earth. Toggle "off" the orbit of Mars so that only the orbits of Earth and Jupiter are traced on the screen.
4. Find the approximate point of **maximum elongation** (this is often called **quadrature**, meaning "one-quarter the way around"). In one year (365.25 days), Earth orbits the Sun. Therefore, the point of maximum elongation is the date of opposition plus  $365.25/4 = 91.3125$  (JD 2452673.50000 + 91.3125 = JD 2452764.8125). This, of course, neglects the relative motion of Jupiter during this same period. See the following screen shots, and note the positions of Jupiter, Earth, and the Sun at the points called "opposition," when Jupiter-Earth-Sun form a straight line. Also note "quadrature," when these objects form a 90-degree angle. In the diagram, this is point "1".

### Opposition

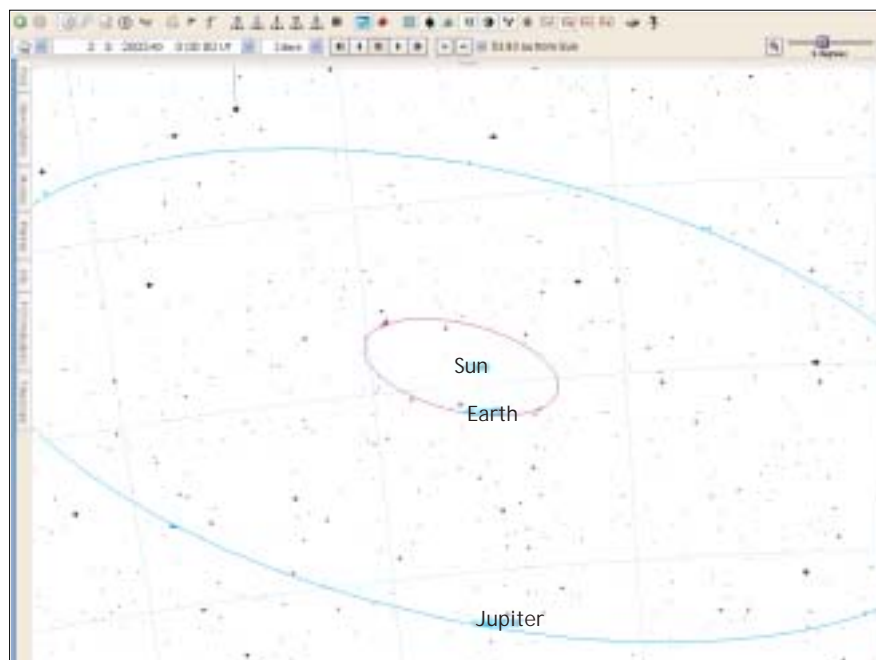

## Quadrature

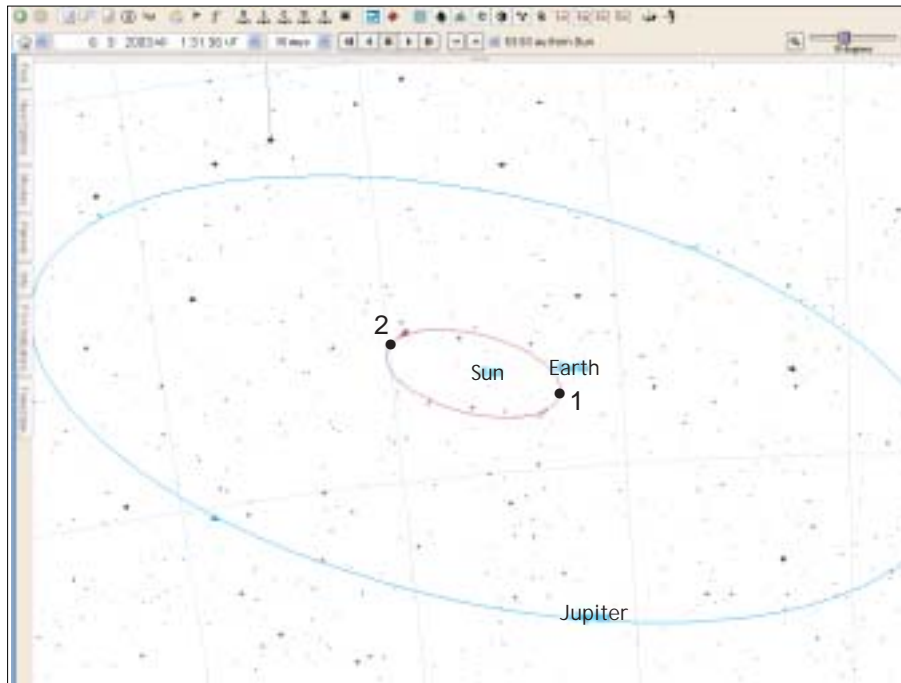

5. In order to work with an appropriate time interval on Earth's orbit, we will identify **two specific points on either side of quadrature**, and call these 'A' and 'B' (refer to the diagram on page 37). Point A represents a position for Earth that is about 20 periods of Io before quadrature, and Point B represents a position that is about 20 periods of Io after quadrature.

Calculate the Julian date (JD) for points A and B (this timespan A→B, represents a total of 40 intervals of Io's orbital period). Rømer had calculated that Io orbits Jupiter, on average, in 1 day, 18 hours, and 28 minutes (1.769 days). Therefore, back up  $20 \times 1.769 = 35.380$  days from the point of quadrature to get to Point A. Using only the significant digits of interest to us in the Julian dates (we call this a Modified Julian Date, or MJD), Point A is at  $\text{MJD } 764.8125 - 35.380 = 729.4325$ . In a similar way, calculate the MJD for point B (MJD is 800.1925).

6. Using *Starry Night*, find the exact Julian date for the eclipse of Io at Points A and B, which represent timings of eclipses when Io exits Jupiter's shadow. We call such an eclipse an "emersion" event. Remember, Earth is moving away from Jupiter during this time interval (MJDs are 729.21667, 800.01597 respectively).
7. Calculate the interval of time between the eclipse at Points A and B (70.7993 days).

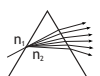

8. Calculate the arc length AB ( $1.8 \times 10^{11}$  m). To simplify, we will take this arc length and consider it a straight line (to accommodate the rectilinear propagation of light).

Radius of Earth's orbit =  $1.496 \times 10^{11}$  m (not known with precision in Rømer's time)

For example,

The sector angle traced out in one day for Earth orbiting the Sun

$$= 2\pi/365.25 \text{ radians}$$

$$= 0.0171937 \text{ radians}$$

Arc length = radius x sector angle (in radians)

$$s = r \cdot \theta$$

$$= (1.496 \times 10^{11} \text{ m})(0.0171937)$$

$$= 1.821 \times 10^{11} \text{ m}$$

9. Calculate the Julian date of quadrature at Point 2 on the other side of Earth's orbit (see diagram on page 37), and repeat steps 5-8 for Points C and D that represent timings of eclipses when Io enters Jupiter's shadow. We call such eclipses *immersion* events, as did Rømer himself. Remember, Earth is now moving towards Jupiter.
- (Point 2 at MJD 947.4375, Point C calculated as MJD 912.0575, and Point D calculated as MJD 982.8175.)
10. Using *Starry Night*, find the exact Julian date for the eclipse of Io at Points C and D that represent timings of eclipses when Io **enters Jupiter's shadow**. We call such an eclipse an "immersion" event. Remember, Earth is moving toward Jupiter during this time interval (MJD 911.41722, 982.20361 respectively).
11. Calculate the interval of time between the eclipses at Point C and D (70.78639 days).
12. Calculate the total difference in the intervals of time for Earth moving away and moving towards Jupiter. This is the amount of time it takes light to travel the interval AB + CD.

$$\text{Total difference in intervals of time} = 70.7933 \text{ days} - 70.78639 \text{ days}$$

$$= 0.00691 \text{ days}$$

$$= 9.9504 \text{ minutes}$$

$$= 597.024 \text{ seconds}$$





13. From your data, calculate the speed of light.

$$\begin{aligned} \text{speed} &= \frac{\text{distance}}{\text{time}} = \frac{\widehat{AB} + \widehat{CD}}{t_1 + t_2} \\ &= (2)(1.821 \times 10^{11} \text{ m})/597.024 \text{ s} \\ &= 6.100 \times 10^8 \text{ m/s} \end{aligned}$$

This value for the speed of light is in the same *order of magnitude* as the modern value.

**Note:** The sketch that follows shows the relative positions of Jupiter and Earth at the two **quadrature** positions. The arc lengths **AB** and **CD** in the previous equation would be equivalent to  $d_1$  and  $d_2$  in the diagram.

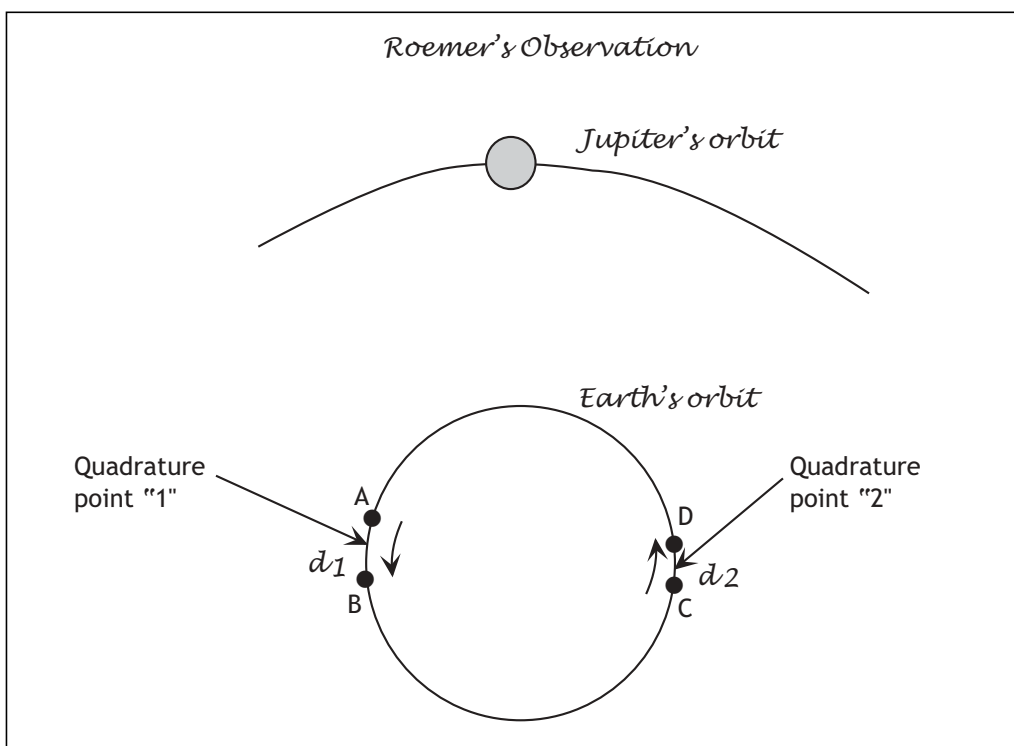

## An Alternative Method Using Rømer's Own Data

In this alternative method, we will use two pairs of eclipses from Ole Rømer's own notes (and rely on Rømer's times too!). One pair will come from an interval when Earth was receding from Jupiter (*emersion events*), and the other pair will be from an interval when Earth was approaching Jupiter (*immersion events*). See the images below for an example of each type of event as they could be seen in modern telescopes from the Paris Observatory.

### “Emmersion” Event: Io Exits Jupiter’s Shadow

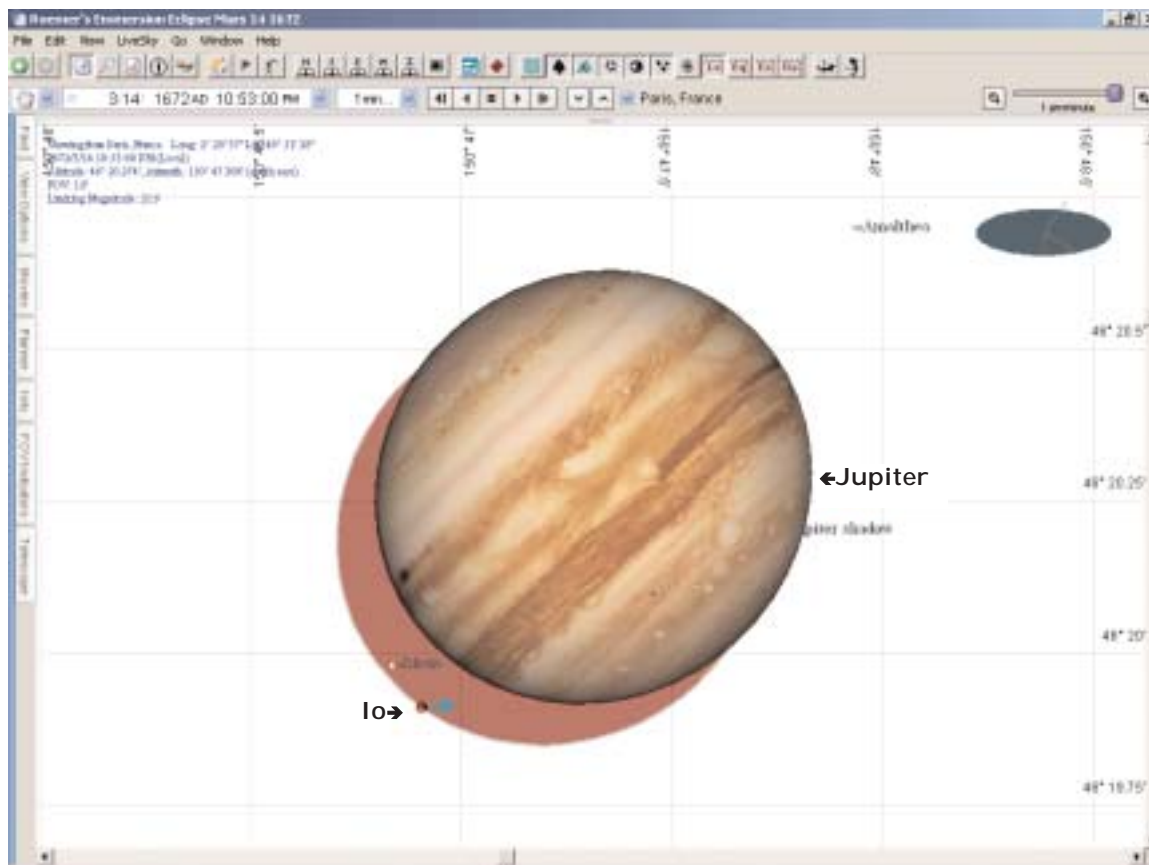

Graphic 1



## “Immersion” Event: Io Enters Jupiter’s Shadow

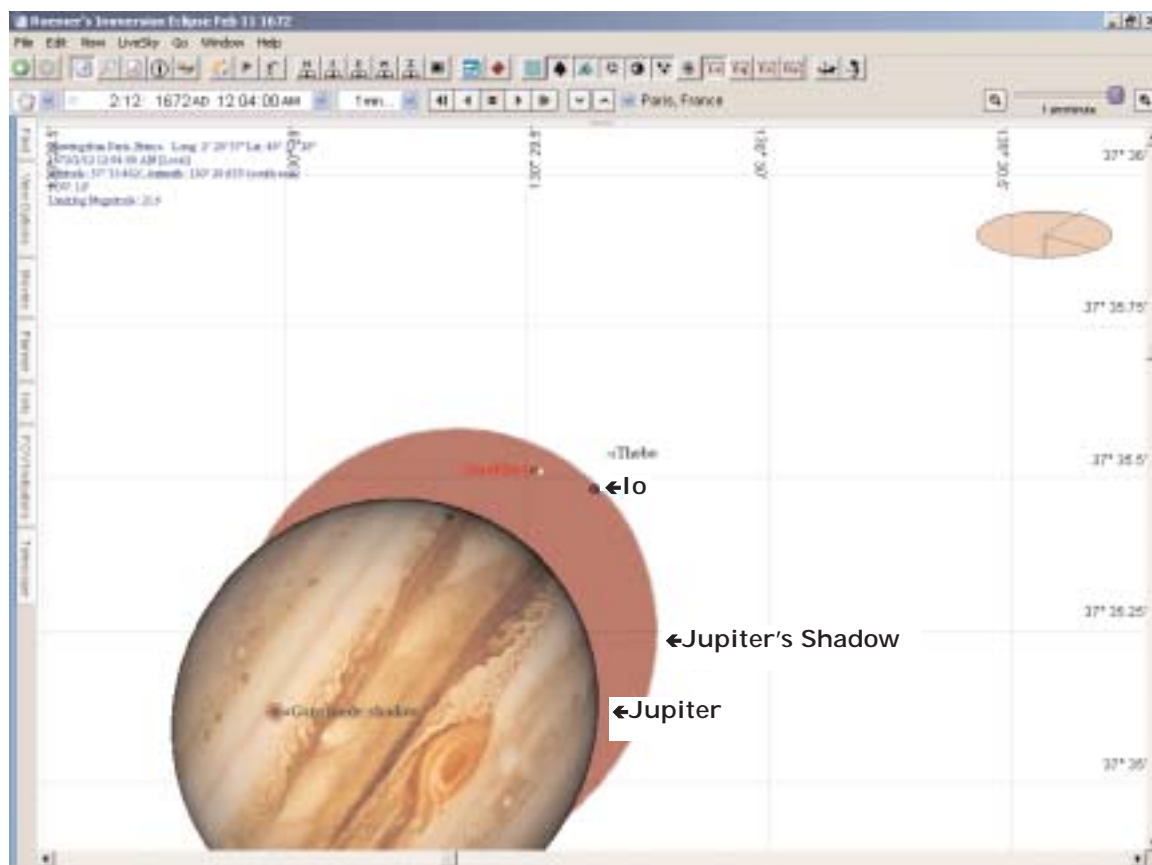

Graphic 2

Rather than use the **arc lengths** AB and CD, as was done in the previous example along Earth’s orbit, we will use direct distances from Earth→Jupiter from the *Starry Night* software. As was found in the previous technique, using pairs of eclipses that are about 70 days apart introduces a significant error in the distance measurement. Light propagates in a straight line to the observer, not along an arc. By taking arc length distances as the distance travelled by light, we introduced a very large systemic error in the calculation of the speed of light. One way to reduce this error significantly is to take pairs of Io eclipses that are very close in time (a few days at most).

1. “Emmersions” at	1672 March 14	JD 2331819.41180
	1672 March 23	<u>JD 2331828.26250</u>
	Interval	8.8507 days
“Immersion” at	1672 February 11	JD 2331787.46111
	1672 February 20	<u>JD 2331796.31041</u>
	Interval	8.8493 days



As we would expect, the second interval (when Earth is approaching Jupiter) is less than the interval when Earth is moving away from Jupiter. It was these irregularities that first intrigued Ole Rømer, and had him consider what such a *mora luminis* ("delay in the light") could mean for determining longitudes.

- Now, determine the difference in the time intervals from (1) and (2) above:  
 $8.8507 \text{ days} - 8.8493 \text{ days} = 0.0014 \text{ days} = 120.96 \text{ seconds}$
- At this point, we need to "modernize" our method, and consult *Starry Night* in order to determine the Earth→Jupiter separation for each of the times listed in parts (1) and (2). Accurate measurements, such as those in *Starry Night* or the *Astronomical Almanac* tables, would not have been available to Rømer.

Earth→Jupiter separation at

1672 March 14 (JD 2331819.41180):	4.4526 A.U.
1672 March 23 (JD 2331828.26250):	<u>4.4956 A.U.</u>
Increase in distance	0.0430 A.U.

Earth→Jupiter separation at

1672 February 11 (JD 2331787.46111):	4.4964 A.U.
1672 February 20 (JD 2331796.31041):	<u>4.4529 A.U.</u>
Decrease in distance	0.0435 A.U.

Adding these two distances together: 0.0865 A.U.

- The result from Step (3) above allows us to calculate the speed of light. Light, from our simulation in *Starry Night*, appears to have taken 120.96 seconds to travel a distance of 0.0865 A.U.

This means the light requires  $120.96 \text{ seconds} / 0.0865 \text{ A.U.} = 1,398.38 \text{ seconds}$  to traverse 1 A.U. (the average distance from the Earth to the Sun) or  $1.496 \times 10^{11} \text{ metres}$ .

$$\text{speed} = \frac{\text{distance}}{\text{time}} = \frac{1.496 \times 10^{11} \text{ m}}{1,398.38 \text{ s}} = 1.07 \times 10^8 \text{ m/s}$$

This result is only ~36% of the modern value of approximately  $3.00 \times 10^8 \text{ m/s}$ , but clearly demonstrates that Rømer's eclipse data can be used to show that light has an extreme velocity when compared to moving objects, such as planets.



### Refining the Technique Using Eclipses of Io Close to Quadrature

Up to now, we have relied upon two techniques that have resulted in unsatisfactory values for 'c'. It remains to attempt one more set of calculations using the Earth-Jupiter distance techniques (Steps 1–4 above) for pairs of eclipses that are very near to quadrature. The reason for this is simple: at these points, the relative speeds of Jupiter and Earth reach their maximum, and the shadows of Jupiter are most pronounced. This allows us to compare this technique with that used earlier in this activity.

Repeat Steps 1–4 from the procedure outlined above (the "Jupiter-Earth" distance technique), but choose pairs of eclipse events that satisfy the following conditions:

- The two eclipse events used are about 4–6 weeks apart
- The pairs of eclipses occur ~6 months apart near the quadratures

1. "Emmersions" at	2001 February 4	JD 2451945.16458
	2001 March 12	<u>JD 2451980.56528</u>
	Interval	35.4007 days

2. "Immersion" at	2001 September 17	JD 2452169.85069
	2001 October 22	<u>JD 2452205.24583</u>
	Interval	35.39514 days

- Now, determine the difference in the time intervals from (1) and (2) above:  
 $35.40070 \text{ days} - 35.39514 \text{ days} = 0.00556 \text{ days} = 480.4 \text{ seconds}$

4. Earth→Jupiter separation at		
	2001 February 4 (JD 2451945.16458):	4.7037 A.U.
	2001 March 12 (JD 2451980.56528):	<u>5.2691 A.U.</u>
	Increase in distance	0.5653 A.U.

Earth→Jupiter separation at		
	2001 September 17 (JD 2452964.50834):	5.3512 A.U.
	2001 October 22 (JD 2452994.59236):	<u>4.8146 A.U.</u>
	Decrease in distance	0.5365 A.U.

Adding these two distances together: 1.1018 A.U.

$$\text{speed} = \frac{\text{distance}}{\text{time}} = \frac{(1.496 \times 10^{11} \text{ m/A.U.}) (1.1018 \text{ A.U.})}{480.4 \text{ s}} = 3.43 \times 10^8 \text{ m/s}$$

At this speed, the light travel time across the diameter of Earth's orbit (i.e., 1 A.U.) would be:

$$\text{Light time} = 1.496 \times 10^{11} \text{ m} / 3.43 \times 10^8 \text{ m/s} = 436.15 \text{ s} = 7.27 \text{ minutes}$$

(The accepted mean value for light time across 1 A.U. is ~8.28 minutes.)



**BLM**Blackline  
Master

## Appendix 2.8: Why Were Eclipse Events at Jupiter Important to 17th-Century Science?

### Jupiter's satellites and the measurement of longitudes in the 17th century

In 1610, Galileo 'discovered' the four largest satellites of Jupiter: Io, Europa, Ganymede, and Callisto. Initially, he named them the *Medicean Stars* in order to honour the family of his most generous patron, the Archduke Ferdinand de Medici. Today, we often refer to these four bodies as the "Galilean Satellites of Jupiter."

The orbits of these satellites have very small eccentricities (they are nearly circular) and are close to the equatorial plane of Jupiter.

Jupiter's equator and its orbit are not much inclined to the plane of the ecliptic.

At the end of the 16th century, the determination of longitudes could not be done very accurately because of the lack of stable and accurate timekeepers—particularly on ships at sea. Galileo then had the idea of using Jupiter's satellites as time indicators: their motions are practically circular and regular; their periods are short enough (on the order of days); and the instants of mutual eclipses do not depend on the location of the observer. This last point is crucial in order to have reliable standards.

This idea—that of using eclipses of Jupiter's largest moons—was taken up again by Cassini in 1668. It eventually met with success, due to the perfection of observational instruments and the invention of a clock that had precision on the order of seconds (by Christiaan Huygens in 1657).

During the winter of 1671-1672, Picard and Rømer (viewing from Uraniborg on the island of Hveen in present-day Sweden, the site of Tycho Brahe's observatory), and Cassini (from the Paris Observatory) observed simultaneously the moments of eclipses of Io by Jupiter. From these measurements, they measured the difference of geographical longitude between Uraniborg and Paris.

From 1672 on, Rømer worked at the Paris Observatory and continued his observations of the eclipses of Jupiter's satellites. Particular emphasis was placed on timings of what was called "the first satellite of Jupiter"—Io.



**SLA**  
Student  
Learning  
Activity

## Appendix 2.9: Becoming Familiar with Ionian Eclipses

The following are some exercises that are related to Io's motion around Jupiter, which put you in a position similar to that of Røemer.

### The Ionian Phenomena

Examine the figure below. The Earth is between a conjunction and an opposition. The radius of the orbit of Io is equal to six times the radius of Jupiter. The angle  $SJE = a$  is always smaller than  $11^\circ$ .

- a) On the figure below, indicate, using the labels  $E_1$ ,  $E_2$ ,  $O_1$ ,  $O_2$ ,  $Sh_1$ ,  $Sh_2$ , and  $P_1$ ,  $P_2$ , the beginning and the end of the following four phenomena:

**Eclipse:** The satellite enters the shadow of Jupiter.

**Occultation:** The satellite, as seen from Earth, goes behind Jupiter.

**Shadow:** The shadow of the satellite is seen on the planet.

**Passage:** The satellite, as seen from Earth, passes in front of the planet.

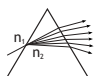
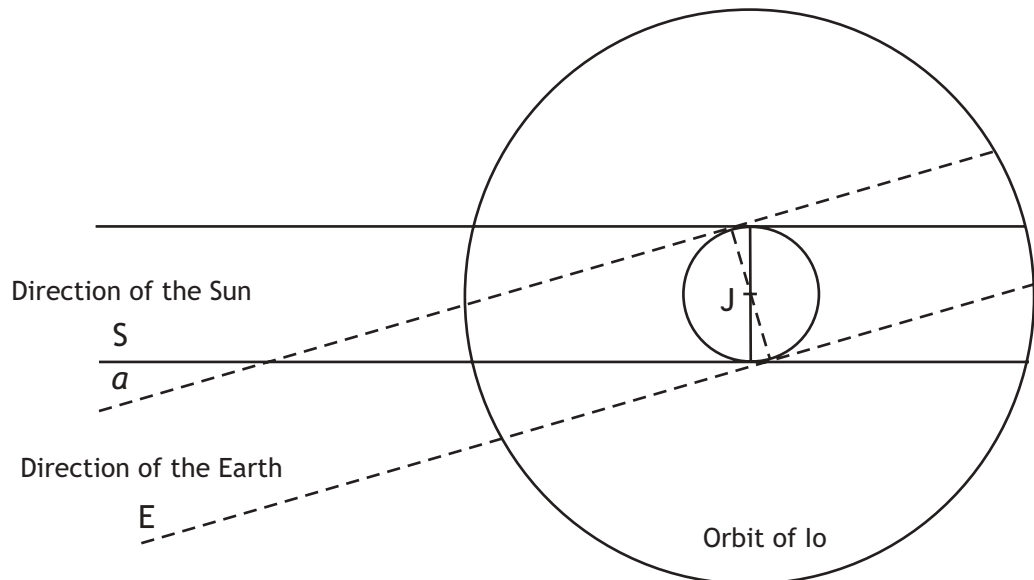

b) Now explain why only the beginnings of the eclipses can be observed from Earth, as seen in the previous diagram.

c) Research what happens when the Earth is close to a **conjunction** with Jupiter and the Sun. Draw a diagram showing the positions of Earth, Sun, and Jupiter when this event occurs.

d) Can we see Jupiter at this time? Why or why not?





- e) Research what happens when the Earth is close to an opposition event with Jupiter and the Sun. Draw a diagram showing the positions of Earth, Sun, and Jupiter when this event occurs.
- f) Draw another figure that shows what happens when the Earth is between an opposition and a conjunction (this occurs twice per calendar year). Explain why only the end or the beginning of the eclipses of Io can be observed from Earth.

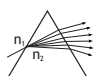

### Reviewing Some Planetary Geometry . . .

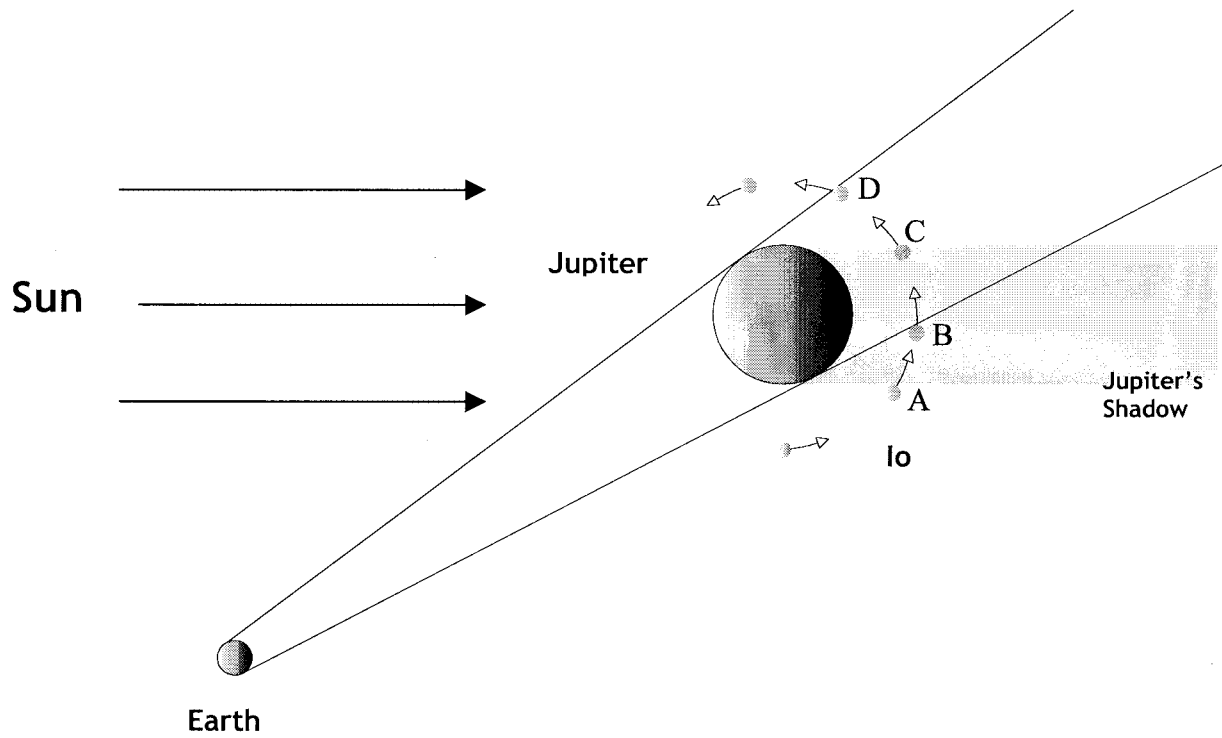

g) Label the above diagram with the following: Direction to the Sun, Earth, Jupiter, Io, Jupiter's Shadow (or umbra).

h) What events occur at the following points? (Don't peek back!)

A \_\_\_\_\_

B \_\_\_\_\_

C \_\_\_\_\_

D \_\_\_\_\_



**SLA**Student  
Learning  
Activity**Appendix 2:10: Simulating Rømer's Eclipse Timings Using *Starry Night Backyard***

**Note:** In order to proceed with this portion of the activity sequence, you will need access to *Starry Night Backyard* (or *Starry Night Pro 4.x*).

A table of Rømer's eclipse timings appears at the end of this activity for ease of removal.

**Procedure for Setting Up an Eclipse in *Starry Night*****Step 1**

Set the location for Paris, France. Set the TIME of the eclipse you wish to view (consult the chart at the end of this activity) by making adjustments to the toolbar as required. Ensure that the software is "stopped." (You can do this by selecting the ■ button on the time increment buttons.)

**Step 2:**

Use the PLANET LIST or Find feature to "lock onto" Jupiter. Once you have locked Jupiter, use the ZOOM feature in order to get Jupiter to be about the size of a "toonie" on the screen. Your screen could look something like this (in *Starry Night Pro*):

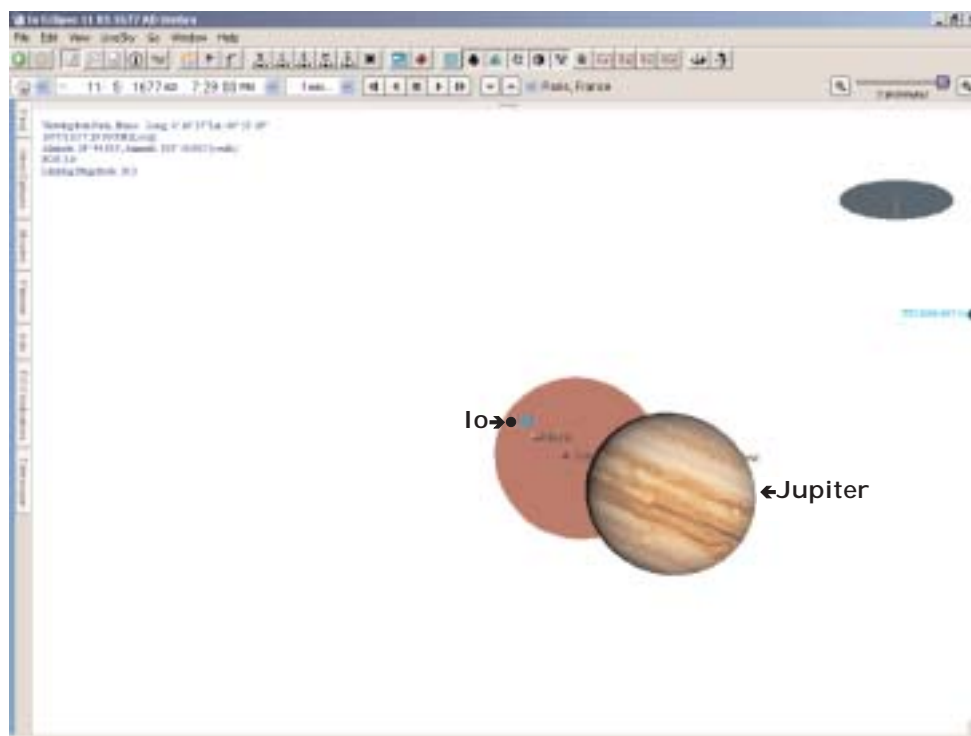
**Graphic 1**

**Note:** Graphics are available online for downloading at <http://www2.edu.gov.mb.ca/ks4/cur/science/default.asp>. Navigate to Physics 30S through the "Curriculum Documents" link.



### Step 3

Using the ► or the ◀ keys on the time panel, and with the time increment set to “minutes,” try to determine the exact moment that Io emerges from the shadow (umbra) of Jupiter. Astronomers call this moment **egress**. You will likely see Io brighten suddenly when this moment occurs.

Your screen could look like this:

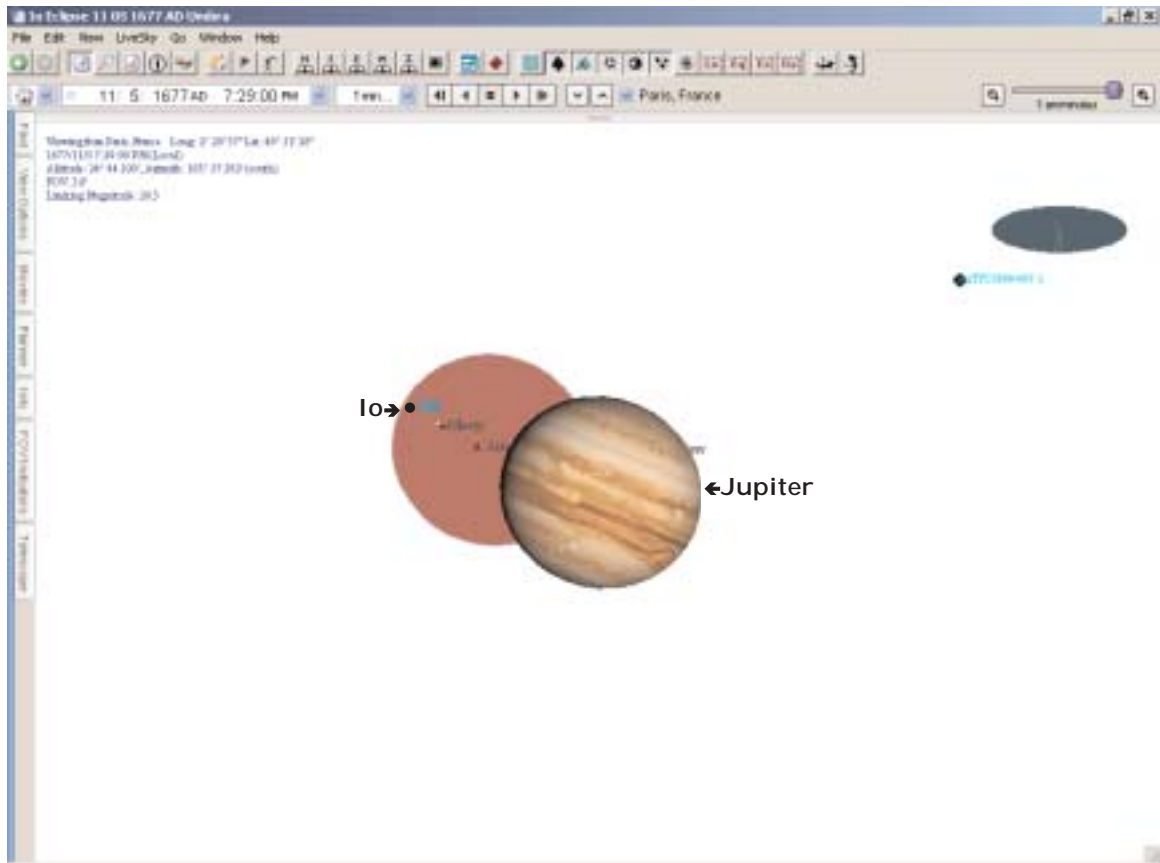

Graphic 2



**Step 4****Locking on Io and observing Jupiter's shadow**

Use the PLANET LIST or Find feature in order to “lock onto” Io. Once you have locked on this moon, use the ZOOM feature in order to get Io to be about the size of a “small disk” on the screen. Your screen could look something like this:

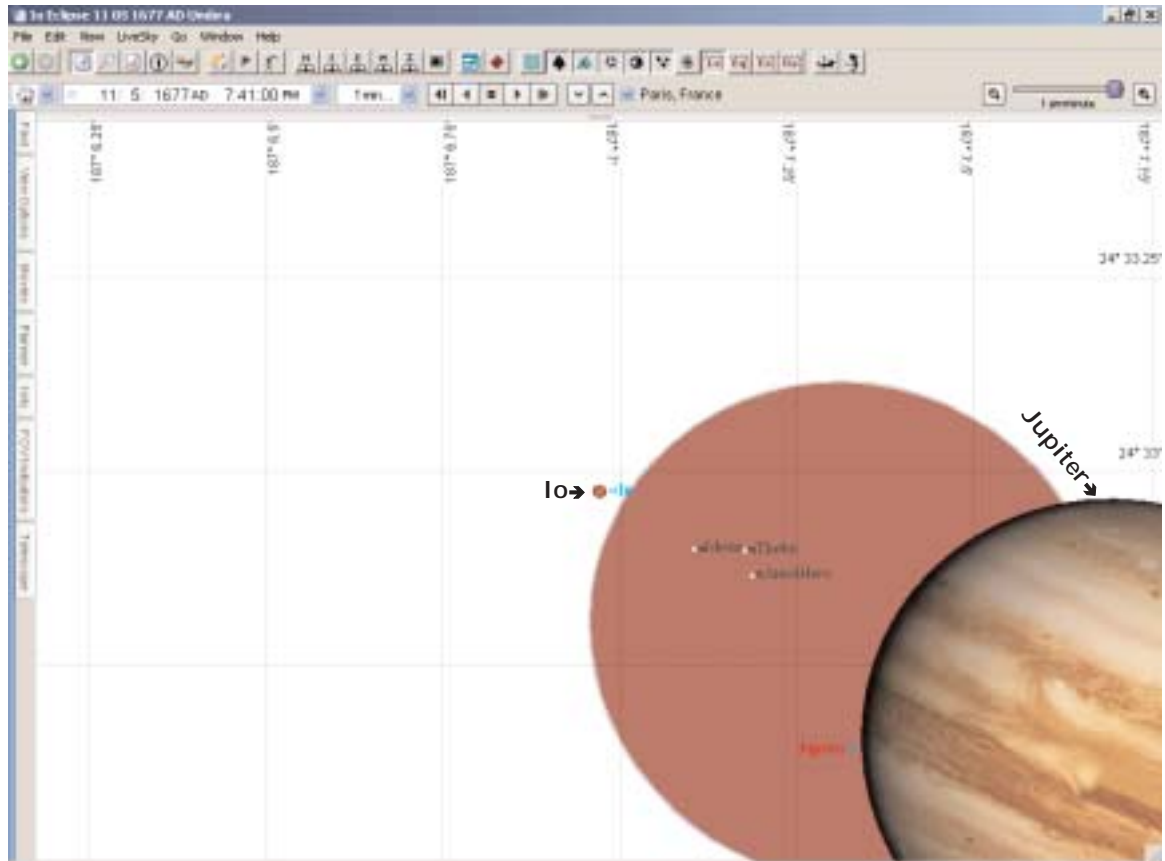
**Graphic 3**

Now, using the time buttons on the toolbar, try to find the exact moment when the shadow of Jupiter crosses the “face” of Io. Fill in the chart on pages 31–32.

Check this time with that of Rømer’s (from the table). Do the two times agree?

What possible explanation could be given if the times do NOT agree with each other?



In another mode (known as “White Sky,” and only available with *Starry Night Pro 4.x*), you can get a good look at Jupiter’s shadow.

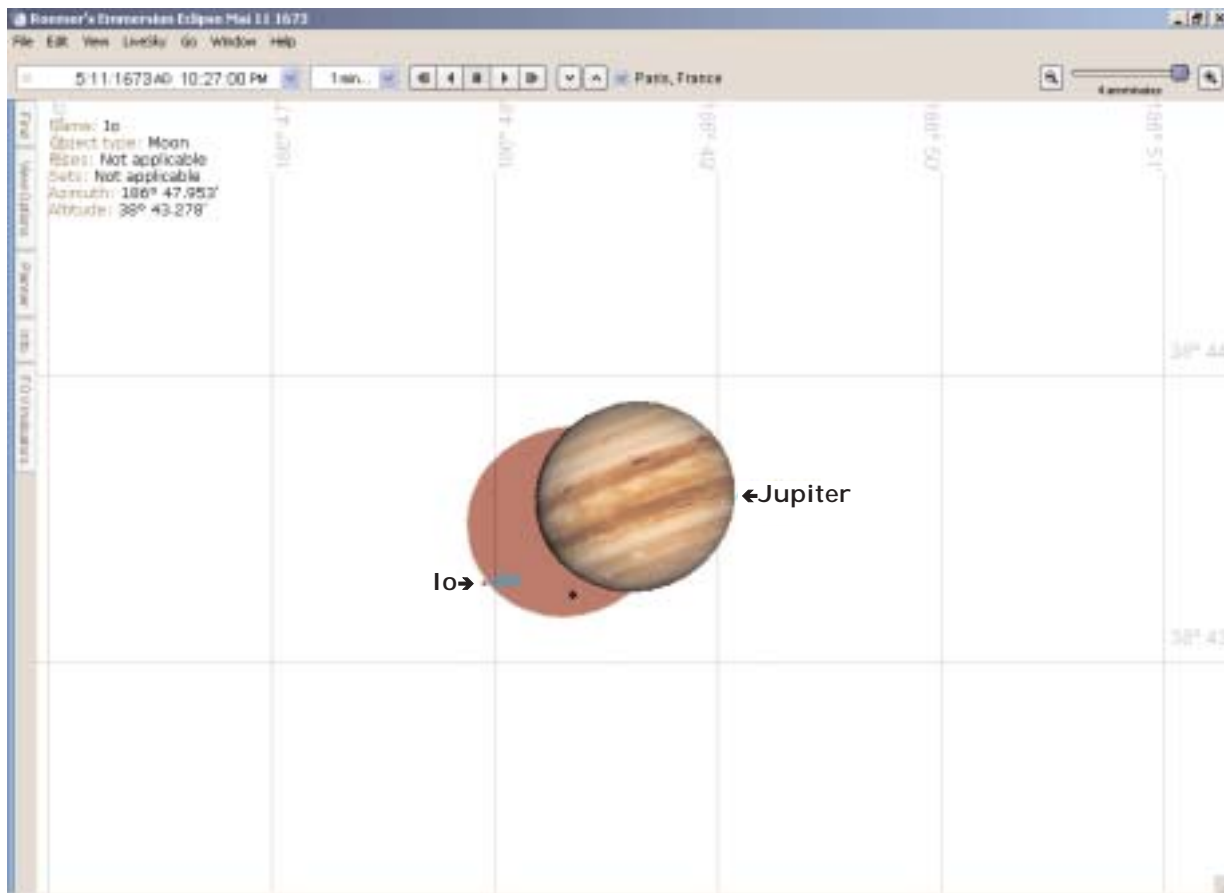

Graphic 4

### Step 5

#### Observing a number of eclipses from Rømer’s notebook data

The information that appears in the chart at the end of this activity includes eclipse timings that are from Ole Rømer’s own notebook. (See Summary of Eclipse Data, pp. 53–54 of this appendix.)

Experiment with some of these to see if there are some “problems” with his data. For instance, could he have been observing the wrong moon (i.e., not Io)? Did an eclipse of Io even occur on the date indicated?

You can record these data in the chart that follows.



Event Date	Transit/ Eclipse	Immersion/ Emmersion	Rømer's Observed Time at Paris Observatory	Observed Time ( <i>Starry Night</i> )	Timing Discrepancy (Rømer vs. Simulation)	Rømer's Timing Early (e) or Late (l)
October 22, 1668	eclipse		10:41 PM			
November 26, 1669	eclipse		11:26 PM			
March 19, 1671	eclipse		10:01 PM			
April 27, 1671	eclipse		7:42 PM			
May 4, 1671	eclipse		9:41 PM			
February 11, 1672	eclipse		10:57 PM			
February 20, 1672	eclipse		8:20 PM			
March 7, 1672	eclipse		7:58 PM			
March 14, 1672	eclipse		9:52 PM			
March 23, 1672	eclipse		7:18 PM			
March 30, 1672	eclipse		8:14 PM			
April 6, 1672	eclipse		10:11 PM			
April 29, 1672	eclipse		10:30 PM			
March 13, 1673	eclipse (Europa)		5:00 AM			
May 11, 1673	eclipse		9:17 PM			
May 18, 1673	eclipse		11:32 PM			
August 4, 1673	eclipse		8:30 PM			
July 31, 1674	eclipse		10:19 PM			

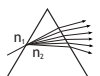

Event Date	Transit/ Eclipse	Immersion/ Emmersion	Rømer's Observed Time at Paris Observatory	Observed Time ( <i>Starry Night</i> )	Timing Discrepancy (Rømer vs. Simulation)	Rømer's Timing Early (e) or Late (l)
July 20, 1675	eclipse		8:26 PM			
July 27, 1675	eclipse		10:17 PM			
October 29, 1675	eclipse		6:07 PM			
August 7, 1676	eclipse		9:49 PM			
August 14, 1676	eclipse		11:45 PM			
August 23, 1676	eclipse		8:11 PM			
November 9, 1676	eclipse		5:45 PM			
August 26, 1677	eclipse		11:31 PM			
September 11, 1677	eclipse		9:14 PM			
September 18, 1677	eclipse		9:41 PM			
September 18, 1677	eclipse		11:51 PM			
November 5, 1677	eclipse		6:59 PM			
January 6, 1678	eclipse		6:25 PM			





**Summary of Eclipse Data from Røemer's Notebooks—For Teachers**

Event Date	Transit/ Eclipse	Immersion/ Emmersion	Røemer's Observed Time at Paris Observatory
October 22, 1668	eclipse	immersion	10:41 PM
November 26, 1669	eclipse	immersion	11:26 PM
March 19, 1671	eclipse	emmersion?	10:01 PM
April 27, 1671	eclipse	immersion	7:42 PM
May 4, 1671	eclipse	immersion	9:41 PM
February 11, 1672	eclipse	immersion	10:57 PM
February 20, 1672	eclipse	immersion	8:20 PM
March 7, 1672	eclipse	emmersion?	7:58 PM
March 14, 1672	eclipse	emmersion	9:52 PM
March 23, 1672	eclipse	emmersion	7:18 PM
March 30, 1672	eclipse	emmersion	8:14 PM
April 6, 1672	eclipse	emmersion	10:11 PM
April 29, 1672	eclipse	emmersion	10:30 PM
March 13, 1673	eclipse (Europa)	emmersion	5:00 AM
May 11, 1673	eclipse	emmersion	9:17 PM
May 18, 1673	eclipse	emmersion	11:32 PM
August 4, 1673	eclipse	emmersion	8:30 PM
July 31, 1674	eclipse	emmersion	10:19 PM



Event Date	Transit/ Eclipse	Immersion/ Emmersion	Røemer's Observed Time at Paris Observatory
July 20, 1675	eclipse	emmersion	8:26 PM
July 27, 1675	eclipse	emmersion	10:17 PM
October 29, 1675	eclipse	emmersion	6:07 PM
August 7, 1676	eclipse	emmersion	9:49 PM
August 14, 1676	eclipse	emmersion	11:45 PM
August 23, 1676	eclipse	emmersion	8:11 PM
November 9, 1676	eclipse	emmersion	5:45 PM
August 26, 1677	eclipse	emmersion	11:31 PM
September 11, 1677	eclipse	emmersion	9:14 PM
September 18, 1677	eclipse	immersion?	9:41 PM
September 18, 1677	eclipse	emmersion	11:51 PM
November 5, 1677	eclipse	emmersion	6:59 PM
January 6, 1678	eclipse	emmersion	6:25 PM



**BLM**

Blackline  
Master

## Appendix 2:11: Contributions to the Determination of the Speed of Light

Name of contributor:	Lifespan (years):	Nationality:
Method(s) used:	Observations:	Inferences:
Value for 'c' determined by method:	Calculation of percentage error based on modern accepted value:	Interesting point about this person's life:



## NOTES



## APPENDIX 3: MECHANICS

# SLA

Student  
Learning  
Activity

### Appendix 3.1: Working with the Modes of Representation

- Define the following terms:
  - interpolation
  - independent variable
  - dependent variable
  - line of “best fit”
- Some of the variables affecting the rate of growth of a plant are amount of sunlight, temperature, amount of water, and amount of fertilizer added. Write the procedure designed to show how the amount of water affects the rate of growth of a plant. Be specific.
- Sketch a graph that shows each of the following mathematical relationships. Include the following in your response:
  - Describe what is happening with the dependent variable as the independent variable is *increasing*.
  - If the  $x$ -axis had data values of 2, 4, 8, and 9, what would be the corresponding values on the  $y$ -axis?
  - Describe a simple situation from your own experiences that might produce a graph of the shape you have drawn.
    - 2nd power
    - square root
    - $y = 5$
    - $y = 1/x$

In the following examples, you will be working with the *four modes of representation*: visual, numerical, graphical, and symbolic.

In each example, include a statement that answers the following:

- ✓ **Visual Mode:** What would you see if you or a friend witnessed the event?
- ✓ **Numerical Mode:** Describe any relationships you see between the variables in the data.
- ✓ **Graphical Mode:** Plot the graph and state, in words, any patterns or relationships you see.
- ✓ **Symbolic Mode:** Using your skills in manipulating data, determine a mathematical relationship between the variables, and state this in *equation form* as words and symbols.



4. An object is dropped from the top of a smokestack near a mine in Thompson. The distance the object has fallen is measured at certain times, as indicated in the data below.

Time (s)	1.1	1.8	2.5	3.8	4.5
Distance (m)	5.4	17	31	72	98

Use the **four modes of representation** outlined on the previous page as you work through this example.

5. An object travels in a circle of fixed radius. The speed,  $v$ , is measured for the object travelling around the circle with different periods,  $T$ . The following data were collected.

Time (s)	0.95	1.2	1.5	1.9	2.5
Speed	13	10	8.3	6.7	4.9

Use the **four modes of representation** outlined on the previous page as you work through this example.

6. A mass suspended from a spring vibrates within a certain period. When the mass is changed, it is noticed and recorded that the period also changes.

Mass (kg)	0.50	0.75	0.90	1.10	1.50	1.90
Time (s)	0.44	0.55	0.60	0.65	0.78	0.88

Use the **four modes of representation** outlined on the previous page as you work through this example.

7. Until the plate tectonics model accounted for the separation of the continents, the idea of an *expanding Earth* was treated very seriously by geophysicists. According to one model, the radius of Earth changed with its volume as follows (we won't use units this time!):

Volume	4.52	14.14	25.25	30.92	34.27	42.45
Radius	1.03	1.50	1.82	1.95	2.02	2.16

Use the **four modes of representation** outlined on the previous page as you work through this example.



**SLA**  
Student  
Learning  
Activity

## Appendix 3.2: A Vector Journey

**Object:** To determine the displacement between two points on a plane (the floor of the school).

**Apparatus:** Measuring device such as a metre stick or a measuring tape.

**Procedure:**

- Start at a given point.
- Using a metre stick or measuring tape, measure the vectors in the north-south direction and the east-west direction that are needed to proceed from the starting point to the end point of your journey.
- The front of the school is (north, south, east, west?) and the gym side of the school is (north, south, east, west?).
- Use any lines on the floor to aid you in maintaining the proper direction.
- List all the vector displacements measured to the nearest 0.1 m in the order that the measurements were made.
- Add these vector displacements in the order that they were made, using a scale diagram.
- Add the collinear vectors for the east-west direction and for the north-south direction. Add these mathematically, using Pythagoras and trigonometry. Include a sketch.
- Repeat these steps for your second vector journey.
- Choose two of the following journeys, making sure they are from different floors.

**Teachers: The following “vector journeys” are samples. Please modify as required**

Main Floor	Start	Finish
	Phys. Ed. Office door	Room _____ door
	Pay phone	Counter in the general office
	Door to Room _____	Door to Library
	Vending machine	Door to Computer Lab
Lower Level		
	Cafeteria door	Back stairwell
	Teacher’s desk	Eyewash station in the science lab
	Door to room _____	Door to chemical storage room
Upper Level		
	Stereo in the student lounge	Door to Room _____
	Front stairs	Stereo in the student lounge



**Report:**

- For each journey, list the displacements measured in the order they were measured.
- Write a description of your journey.
- Show the work in determining the displacement for each journey, both by a scale diagram and through mathematical calculations.
- How do the displacements found by the different methods compare?





**SLA**Student  
Learning  
Activity**Appendix 3.3: Journal Entry on Vectors****Part A**

Using the Three-Point Approach Frame (supplied to you), define and illustrate the following terms.

Vector	Magnitude	Quantity
Scalar	Direction	Unit
Vector diagram	Scale	Collinear vectors
Vector components	Reference system	Resultant

**Part B**

Answer the following questions in your journal.

1. Find the components of the following vectors:

a)  $\vec{A} = 358 \text{ km } 16.0^\circ \text{ north of west}$

b)  $\vec{B} = 0.255 \text{ m/s/s NW}$

c)  $\vec{N} = 1.25 \text{ m/s } 50.2^\circ \text{ south of east}$

2. What is the vector for which the components are 38.3 m E and 71.6 m S?

3. Add the following vectors, using the algebraic method:  $\vec{A} = 6.35 \text{ m N}$  and  $\vec{B} = 9.23 \text{ m W}$ . Write a description of the steps performed to add these vectors.

4. Add the vectors  $\vec{A}$  and  $\vec{B}$  from the previous question, using a scale diagram. Again, write a description of the steps performed to add these vectors, using a scale diagram.

5. A plane is flying at 225 km/h east. Some time later, it is flying at 225 m/s south. What is the change in velocity?

6. Given the vectors:

$$\vec{A} = 0.250 \text{ m E};$$

$$\vec{B} = 0.350 \text{ m E};$$

$$\vec{C} = 0.150 \text{ m N}$$

Determine:

a)  $\vec{A} + \vec{B} + \vec{C}$ , in that order, using a *scale diagram*.

b)  $\vec{B} - \vec{C}$ . Write a description of the steps performed in finding this difference.





### Appendix 3.4: A Vector Sampler

1. Distinguish between a vector and a scalar. Illustrate each with an example.
2. Determine the components of the vector  $\vec{M} = 45.7 \text{ m/s } 18.7^\circ \text{ east of south}$ .
3. A boat can travel in still water at  $2.78 \text{ m/s}$ . The boat is on a river that flows at  $1.24 \text{ m/s}$  in a southerly direction. Calculate the velocity of the boat relative to the shore if:
  - a) the boat heads upstream.
  - b) the boat heads downstream.
  - c) the boat heads in an easterly direction across the river.
4. For the boat and the river in Question #3, what heading must the boat take to land on the western shore of the river directly west of the starting point on the east shore?
5. A plane flies at an airspeed of  $225 \text{ km/hour}$  west. A south wind is blowing at  $105 \text{ km/hour}$ . Determine the velocity of the plane as observed from the ground.

6. Given the vectors:

$$\vec{K} = 28\,900 \text{ m South}, \quad \vec{L} = 17\,400 \text{ m West}$$

$$\vec{M} = 21\,200 \text{ m East}, \quad \vec{N} = 15\,700 \text{ m North}$$

Determine the following using the suggested strategy:

- a)  $\vec{K} + \vec{L} + \vec{N}$ , in that order using a *scale diagram*.
- b)  $\vec{M} - \vec{N}$ , using *trigonometry*.
- c)  $\vec{K} + \vec{L} + \vec{M} + \vec{N}$ , using *trigonometry*.
- d)  $\vec{M} - \vec{L}$



**SLA**Student  
Learning  
Activity**Appendix 3.5: Analysis of Data Using *Microsoft Excel***

Instead of manually drawing your graphs of the raw data and then manipulating the data, you can easily do the graphing in *Excel*. Follow the same three steps, namely:

1. Draw the graph of the raw data.
2. If the line is not straight, use proportioning to determine the variance and manipulate the data to create a new data chart.
3. Graph these manipulated data and find the equation, using  

$$\text{Dependent Variable} = (\text{Constant}) \times \text{Independent Variable},$$
 where the constant is the **slope** of the graph.

**Using *Excel*:**

Open *Excel* and enter the following data:

Pressure (ATM)	Volume (L)
1.25	20.0
2.00	12.5
3.33	8.02
4.24	5.82
6.89	3.50

**1. Graphing the Raw Data**

Select the two columns including the headings.

Select the Chart Wizard.

Step 1: Select the X-Y Scatter option, then choose the "Scatter connected by smooth lines" type of graph. Click "Next."

Step 2: This should be fine. Click "Next."

Step 3: Fill in the titles. Y = Volume (L), X = Pressure (ATM).

Select the "Gridlines" tab and select major axis and minor axis for both X and Y. This produces a grid on your graph.

Click "Next."

Step 4: Select "Place object in Sheet 1."

Click "Finish."

This gives you a graph of the **raw data**. Note that the line is a curve representing an **inverse** or **indirect** relation.



## 2. Manipulating the Data

You must now manipulate the data so that you can obtain a **straight-line** graph. The graph suggests you must take the reciprocal of the **pressure** and make a new chart.

Make two headings: **1/Pressure (ATM<sup>-1</sup>)** and **Volume (L)**.

In the first cell below the **1/Pressure** heading, type =1/.

Then, select the first cell below the **pressure** heading in the raw data.

The designation of that cell (i.e., A2) should appear. You should now see 1/A2.

Press **Enter** and the calculated value of the reciprocal of the pressure appears.

Select this calculated value and a box with a cross in the lower right-hand corner will appear. Drag this cross down the column and the remaining values will be calculated for 1/Pressure.

Select the volume readings, then cut and paste into the new table.

Here is what you should have:

1/Pressure (ATM) <sup>-1</sup>	Volume (L)
0.800	20
0.500	12.5
0.300	8.02
0.236	5.82
0.145	3.5

Now, repeat the steps in “Graphing the Raw Data” to make a graph of the manipulated data.

Your graph should be **almost** a straight line.

To make the **Best Fit Line**, select Chart from the menu bar, then select Add Trendline. Under the Type tab, choose Linear.

Select OK.

Resize the graph to make it larger.

Click on the graph in between gridlines to call up the Format Plot Area.

In the Area section, select white as the colour and click OK.

You now have a straight-line graph!



### 3. Making the Equation

The proportional relationship is:

$$\text{Volume} \propto 1/\text{Pressure}$$

and the equation is  $V = (K)(1/P)$ .

From the graph, find the slope. Pay attention to units.

$$\text{Slope} = \frac{\Delta V}{\Delta(1/P)} = \frac{25 \text{ L}}{\text{ATM}^{-1}}$$

$$\text{Volume} = \frac{25 \text{ L}}{\text{ATM}^{-1}} (1/\text{Pressure})$$

To find the **slope** of the graph, use the Linset function.

Syntax =Index(Linset(array of Y values, array of X values),1)

All other relations are analyzed in the same way except for the manipulation of the raw data.

Here are the formulas you need, in *Excel*, in order to manipulate the data for:

1. Second power (exponent of "2")

=POWER(number, power)

Example =Power(8,2)

Press Enter to obtain 64

In the table you are making, in the Formula Bar (where your typing appears), replace the "number" with the cell designation of the first reading, (i.e., = POWER(A2,2)). Then proceed to change the rest of the data.

2. Third power (exponent of "3")

=POWER(number,3)

3. Inverse square (exponent of "-2")

=POWER(number,-2)

4. Square root (exponent of "1/2")

=POWER(number,0.5)





### Appendix 3.6: Describing Motion in Various Ways

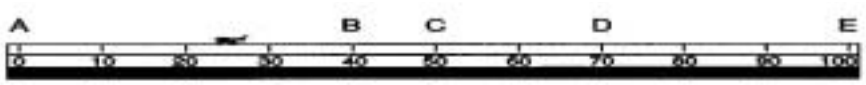

1. A somewhat confused ladybug is moving back and forth along a metre ruler. Determine both the displacement and distance travelled by the ladybug as it moves from:
  - a) A to B
  - b) C to B
  - c) C to D
  - d) C to E and then to D.
  
2. In the diagram above, EAST points to the RIGHT. During which of the intervals in #1 is the ladybug moving in the EASTERLY direction? In the WESTERLY direction?
  
3. Below is a table showing the position above the ground floor of an elevator at various times. On the graph to the right of the table, plot a graph of position-time.

Time (seconds)	0	4	8	12	16	20	24
Position above the ground floor (m)	4.0	8.0	8.0	16	20	20	12

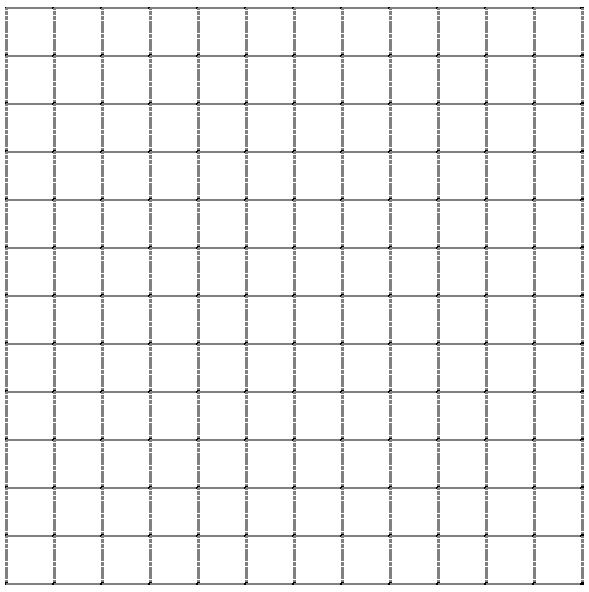

4. A troubled student is waiting to see the principal. He paces back and forth in the hallway in front of the principal's office. The hallway runs north and south. The door to the office is our origin, 0 m. Here is a description of the student's motion.

The student starts at 5.0 m N. He walks to the south for 7.0 m during 10 s. He stands still for 5.0 s. He turns around and walks 15.0 m N during 15.0 s. He stops to say "Hello" to a friend and remains still for 10.0 s. Finally, the principal calls him to the office door. It takes the student 10.0 s to reach the door.

- What is the total time the student spent in the hallway?
- What was the distance travelled by the student during his pacing?
- What was the average speed of the student during his pacing?
- On the graph below, plot time on the horizontal axis and position on the vertical axis. Use straight-line segments to join the points of position-time that you plot.

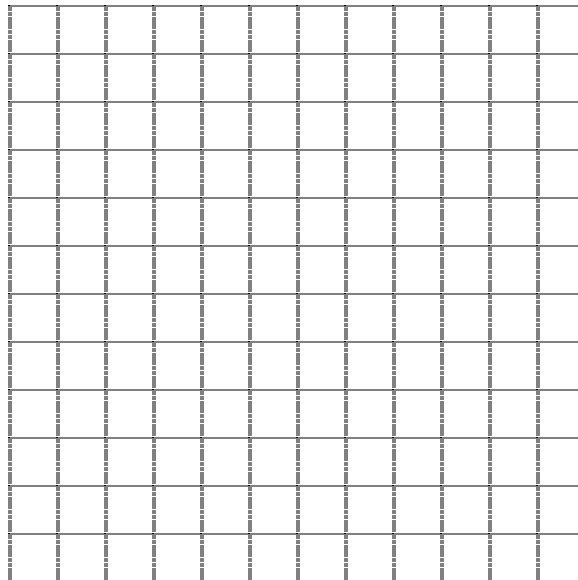

- What is the total displacement for the student's journey? Find this from the graph.
- What is the average velocity for the whole journey?





## Appendix 3.7: Introducing Motion: Position, Time, Distance and Speed, Displacement, and Velocity

**Purpose:** To determine the position of a person moving in a straight line at different instants in time.

To interpret a position-time graph to obtain distance travelled, speed, displacement, and velocity.

### Apparatus

50 metres of hallway or field, stopwatches, measuring tape

### Procedure

#### Part A:

- Using the measuring tape, mark off 5-m intervals along the edges of some floor tiles. Place a piece of masking tape at each 5-m mark. Mark these positions using small signs, like yardage markers along the sidelines of a football field.
- Have a student with a stopwatch stand at each of the markers.
- Have one student begin at the 0-m mark. When the student begins to move, all timers start timing with the stopwatches.
- The student is instructed to walk at a constant rate the full length of the course. As the walking student passes each timer, the timer will stop the stopwatch.
- The timers will then share their times and positions with the group.

### Observations

Description of motion:

Draw a picture of the motion:

Time (seconds)											
Position (metres)											





On the graph below, label time on the horizontal axis and position on the vertical axis and plot the points from the data table. Draw in the line of best fit.

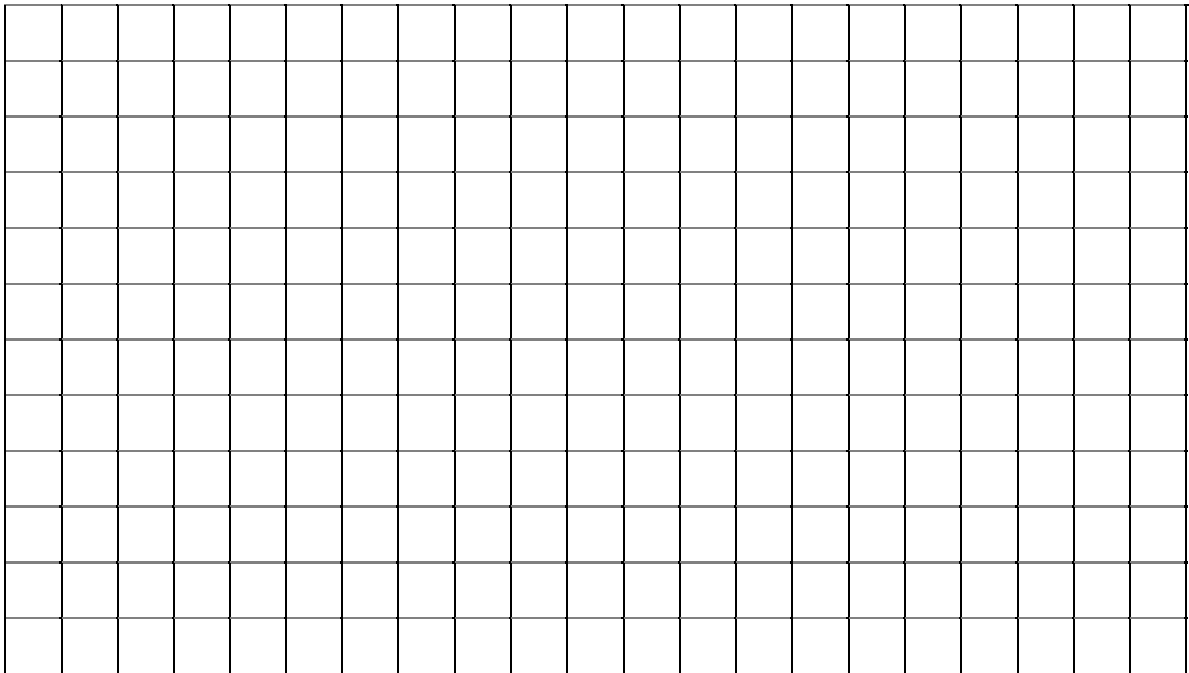

**Procedure**

**Part B**

The student will start from the 0-m mark this time and walk more quickly than before but at a constant rate over the whole course. Again, the timers will start timing when the student begins to move and stop timing when the student passes the timers' positions.

**Observations**

Description of motion:

Draw a picture of the motion:

Time (seconds)										
Position (metres)										

Plot this information on the graph above, using a different colour for these points. Draw in the line of best fit.

**Procedure**

**Part C**

The student will start from the 0-m mark this time and run at a constant rate over the whole course. Again, the timers will start timing when the student begins to move and stop timing when the student passes the timers' positions.

**Observations**

Description of motion:

Draw a picture of the motion:

Time (seconds)											
Position (metres)											

Plot this information on the graph, using a third colour for these points. Draw in the line of best fit.

- Using the descriptions of the motion, how do the starting points compare for the three trials?
- From the graph, determine the starting point for each of the three trials. Compare these to the answers in Part B.
- From the description of the motions, what is the same about all three motions?
- From the description of the motion, what is different about the three motions?
- On the graph, what is different about the three lines?



**Procedure**

**Part D**

The student will start from last mark this time and walk quickly but at a constant rate over the whole course, ending up at 0 m. Again, the timers will start timing when the student begins to move and stop timing when the student passes the timers' positions.

**Observations**

Description of motion:

Draw a picture of the motion:

Time (seconds)											
Position (metres)											

Plot this information on the graph (in Part A), using a fourth colour for these points. Draw in the line of best fit.

**Analysis**

1. How does this fourth line differ from the other three lines on the graph?
  
2. From the description of the motions, can you relate something about the line to the motion it represents?

Line 1:

Line 2:

Line 3:

Line 4:



**Procedure**

**Part E**

Station two timers at the 10-m mark. The student will start from the 0-m mark this time and walk quickly to the 10-m mark. The first timer will stop the stopwatch. The student will stay at the 10-m mark for a slow count of 5. At the count of 5, the second timer will stop his stopwatch and the student will resume her journey covering the whole course at a slower pace than before. Again the timers will start timing when the student begins to move and stop timing when the student passes the timers' positions.

**Observations**

Description of motion:

Draw a picture of the motion:

Time (seconds)											
Position (metres)											









7. For each trial (A through E), calculate the **average velocity** for the journey. Show the equation and the work for each calculation.

8.

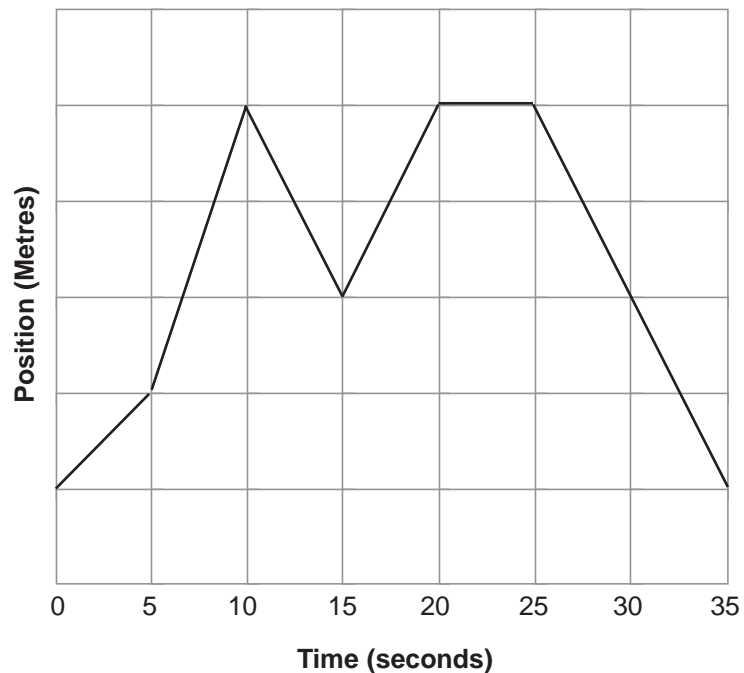

The graph of position-time above shows the position of a soccer linesman running along the sideline of a soccer field during a soccer game.

The 0-m mark is located at the goal line at the south end of the field. All the positions are marked north of that starting point.

- a) Where does the linesman start his journey?
  
- b) During which time intervals is the linesman moving to the north?  
 To the south?  
 Not moving?





- c) What is the distance travelled and the displacement for each interval listed below? Include direction with displacement.

Time Interval	Distance Travelled	Displacement
0–5 seconds		
5–10 seconds		
10–15 seconds		
15–20 seconds		
20–25 seconds		
25–35 seconds		

- d) Calculate the average speed and the average velocity of the linesman for each time interval.

Time Interval	Average Speed	Average Velocity
0–5 seconds		
5–10 seconds		
10–15 seconds		
15–20 seconds		
20–25 seconds		
25–35 seconds		





### Appendix 3.8: Motion: Interpreting Position-Time Graphs



The position-time graph above represents the motion of a remote-controlled toy truck as it moves back and forth along a straight line. The origin marks the position of the boy who controls the truck. The boy has not yet learned how to make the truck change its direction.

A positive position marks positions to the right of the boy, and a negative position marks positions to the left of the boy.

1. During which time intervals is the truck to the right of the boy?  
 To the left of the boy?
2. During which time intervals is the truck moving in the positive direction?  
 In the negative direction?  
 Not moving?
3. What is the position of the truck at 0 seconds? \_\_\_\_\_ 15 seconds? \_\_\_\_\_  
 30 seconds? \_\_\_\_\_ 45 seconds? \_\_\_\_\_



4. When is the truck in front of the boy?
  
  
  
  
  
  
  
  
  
  
5. Describe, in words, the position-time story of the motion that the truck showed during this 50-second interval.

The graph of position-time gives **directly** some information about the motion. This tells the position-time version of the story of this motion (that is, where the truck is at a particular instant in time).

The graph of position-time also gives **indirect** information about the motion of the truck. The following questions deal with obtaining this indirect information, such as distance travelled, displacement, average speed, and average velocity.

6. How far did the truck travel during the following time intervals?

0–10 s \_\_\_\_\_      10–15 s \_\_\_\_\_      15–25 s \_\_\_\_\_  
25–35 s \_\_\_\_\_      35–40 s \_\_\_\_\_      40–50 s \_\_\_\_\_

7. What was the displacement of the truck during the following intervals?

0–10 s \_\_\_\_\_      10–15 s \_\_\_\_\_      15–25 s \_\_\_\_\_  
25–35 s \_\_\_\_\_      35–40 s \_\_\_\_\_      40–50 s \_\_\_\_\_

8. Average speed is given by the distance travelled divided by the time interval. Calculate the average speed for each interval:

0–10 s \_\_\_\_\_  
10–15 s \_\_\_\_\_  
15–25 s \_\_\_\_\_  
25–35 s \_\_\_\_\_  
35–40 s \_\_\_\_\_  
40–50 s \_\_\_\_\_



9. The following relationship is used to calculate average velocity:

$$\text{average velocity} = \text{displacement/time interval or } \vec{v}_{\text{average}} = \frac{\overline{\Delta d}}{\Delta t}$$

This relationship also represents the slope of the line on a position-time graph. Calculate the average velocity for each time interval by calculating the slope of the line segment. Show your work.

Run = $\Delta t$ Time Interval	Rise = $\Delta d$ Displacement	Slope = $\vec{v}_{\text{average}} = \frac{\overline{\Delta d}}{\Delta t}$

10. How do the signs (+, -) of the velocities in Question #9 above compare with the direction of motion in Question #2?

11. In terms of the truck's motion, what does a negative velocity mean?

A positive velocity?

A velocity of 0 m/s?



12. Draw a chord joining the initial position of the truck at 0 s to its final position at 50 s. The slope of this chord represents the average velocity for the whole journey. Calculate the **average velocity** for the whole journey represented by the position-time graph.

13. Displacement is a **vector** quantity. It is always stated with a direction. Distance travelled is just how far an object moves without regard to direction. Distance is a **scalar** quantity.

From the chart on the previous page, determine the distance travelled during each time interval and then calculate the total distance travelled during the 50-s interval.

Calculate the **average speed** of the truck.



14. The average speed for any time interval can be found by drawing a chord joining the position at the first instant in time to the position at the second instant in time. The slope of this chord gives the average velocity for that interval.

Calculate the average velocity for the time interval from 5 s to 35 s.

Calculate the average velocity for the time interval from 15 s to 50 s.







## Appendix 3.9: Journal Entry: Kinematics (Position and Velocity)

### Part A

1. On the Three-Point Approach form, define and illustrate the following terms:

Frame of reference	Kinematics	Clock reading
Time interval	Position	Displacement
Slope	Rate	Speed
Uniform motion	Constant velocity	Tangent
Instantaneous velocity	Constant speed	

2. On the Compare and Contrast Frame, compare and contrast the following:  
 a) velocity and speed  
 b) average velocity and average speed

3. Complete the Category Concept Map for the following:

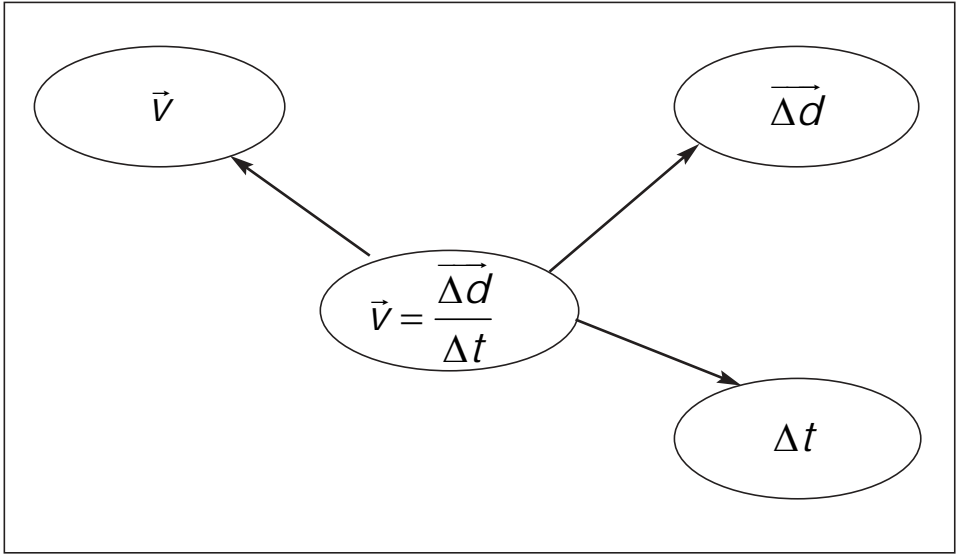





4.

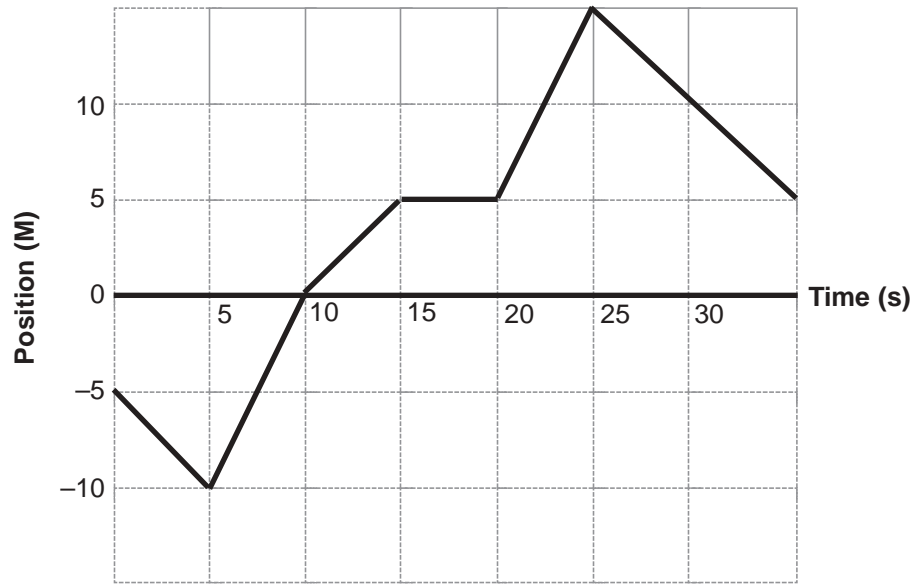

The graph above depicts the motion of a student who, while waiting to see the principal, is pacing the hallway outside the principal's door. The principal's door is at the origin.

- Make a chart finding the velocity for each interval.
- Draw a graph of this velocity-time data.
- Calculate the average speed and the average velocity for this journey.
- Write a story describing the motion of this student depicted by your graph of velocity-time.



**SLA**

 Student  
Learning  
Activity

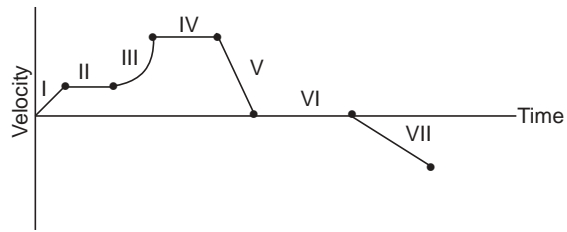
**Appendix 3.10: Kinematics: Position, Velocity, and Acceleration Graphs**

1. The graph above represents the velocity as a function of time for an object that is moving back and forth along a straight line.
  - a) For each interval:
    - i) indicate whether the velocity is positive, negative, or zero.
    - ii) indicate whether the velocity is steady, increasing at a steady rate, increasing at a rate that is not steady, decreasing at a steady rate, decreasing at a rate that is not steady.
    - iii) indicate whether the acceleration is positive, negative, or zero.
  - b) Over which interval would the object travel through the greatest distance? Assume that each segment of the graph lasts for the same amount of time. Explain your answer.

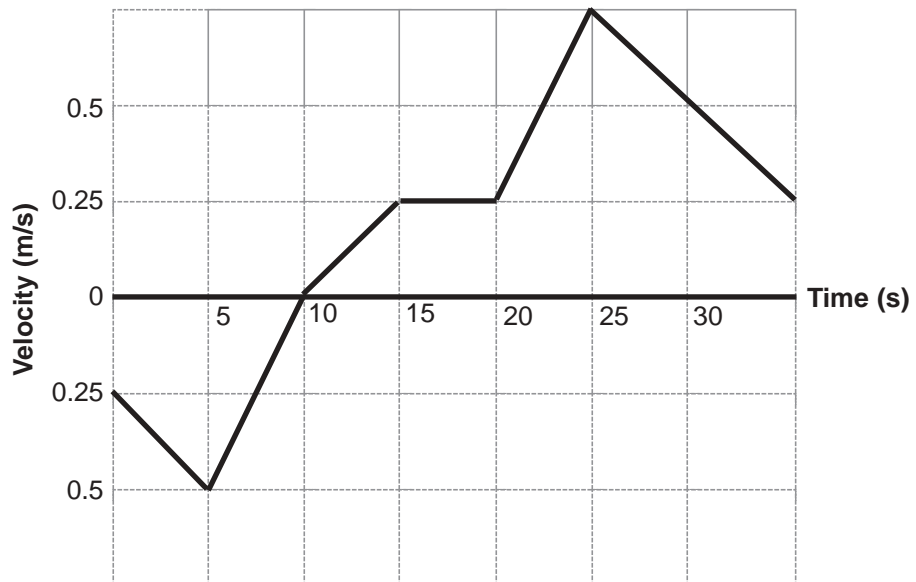

2. For the graph of velocity-time given above, plot a graph of position-time.
  - a) Make a table indicating how the positions were calculated. At  $t = 0$  s,  $x = 3.0$  m.
  - b) Plot the graph of position-time.



3. For the velocity-time graph used in Question #2 on the previous page, plot a graph of acceleration-time.
  - a) Make a table showing how the acceleration was calculated for each interval.
  - b) Draw the acceleration-time graph.
  - c) Determine the average acceleration between 5 s and 20 s.
4. A basketball is thrown straight upwards. The ball slows down as it rises, comes to a stop, and returns to the person's hand with the same speed with which it was thrown upwards. One beneath each other, draw graphs of position-time, velocity-time, and acceleration-time for this motion.

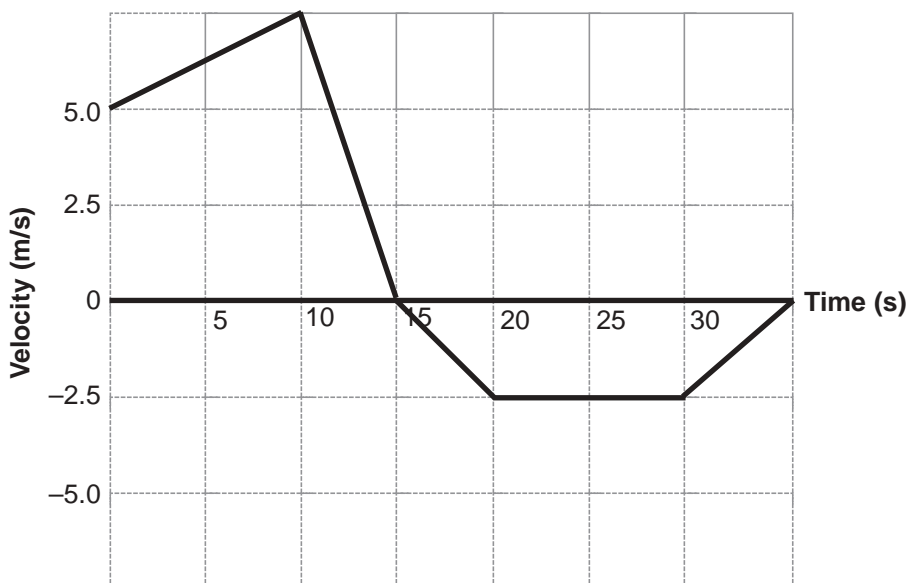

5. For the graph above, if the positive direction is west, determine the following:
  - a) the instantaneous acceleration at 20 s.
  - b) the instantaneous acceleration at 10 s; at 30 s.
  - c) the time interval during which the speed is the largest.
  - d) the time interval(s) during which the displacement is negative.



**SLA**  
Student Learning Activity

**Appendix 3.11: Kinematics and Graphing Skills Builder**

1. a) For the graph below, make a chart and draw the graph for position-time. Assume the object starts at  $t = 7$  at a position of  $-12$  m.

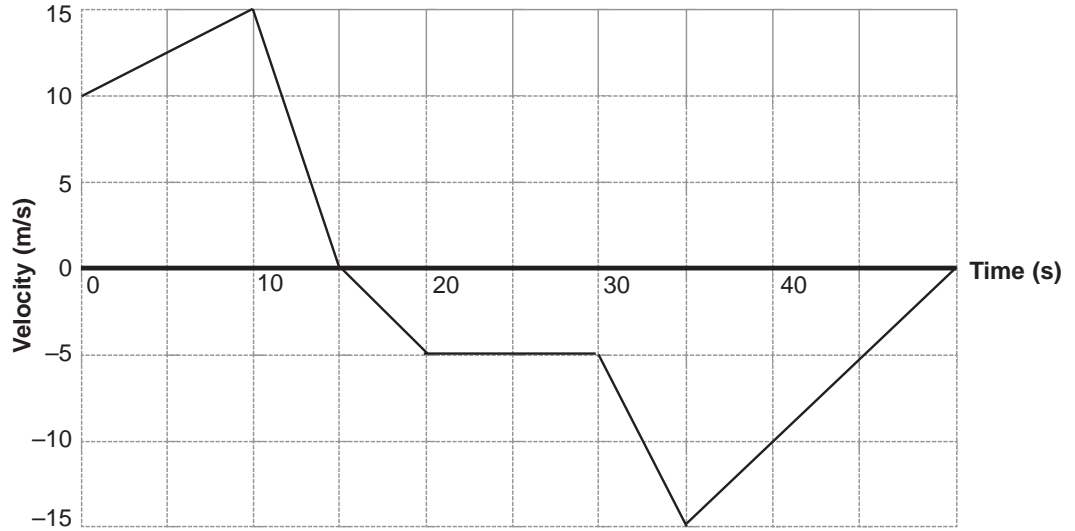

- b) For the graph above, plot a graph of acceleration-time.  
 c) Calculate the average velocity.  
 d) Calculate the average acceleration.
2. For the graph below:
- a) determine the instantaneous velocity at 5.0 s.  
 b) demonstrate the time intervals when the velocity was positive and when it was negative.

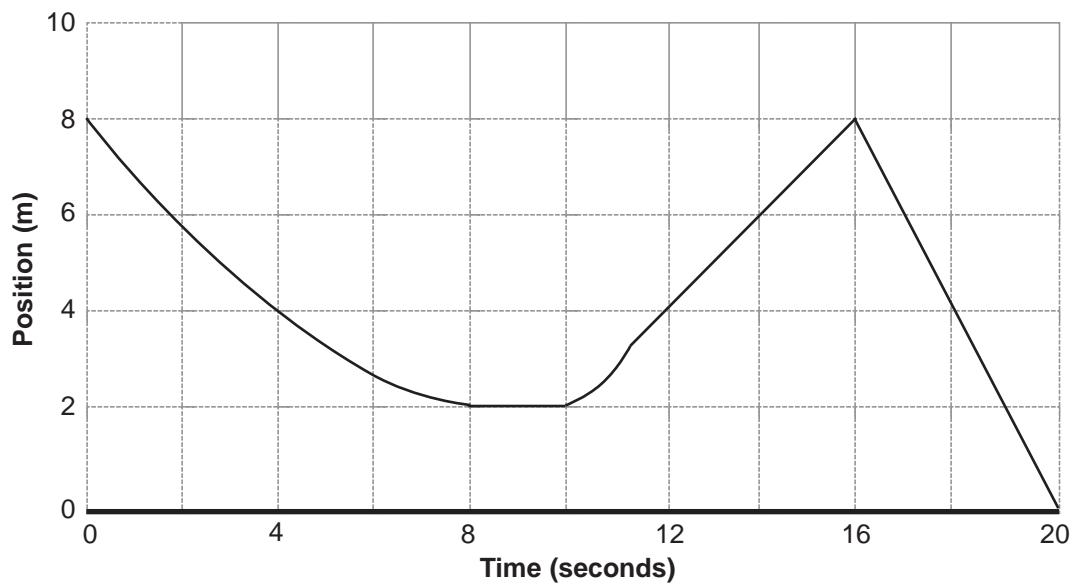



**SLA**

 Student  
Learning  
Activity

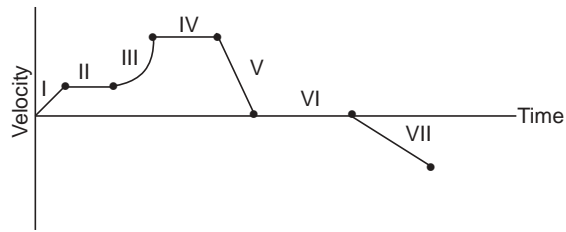
**Appendix 3.12: Kinematics: Position, Velocity, and Acceleration Graphs, and Their Equations**

1. The graph above represents the velocity as a function of time for an object that is moving back and forth along a straight line.
  - a) For each interval:
    - i) indicate whether the velocity is positive, negative, or zero.
    - ii) indicate whether the velocity is steady, increasing at a steady rate, increasing at a rate that is not steady, decreasing at a steady rate, decreasing at a rate that is not steady.
    - iii) indicate whether the acceleration is positive, negative, or zero.
  - b) Over which interval would the object travel through the greatest distance? Assume that each segment of the graph lasts for the same amount of time. Explain your answer.

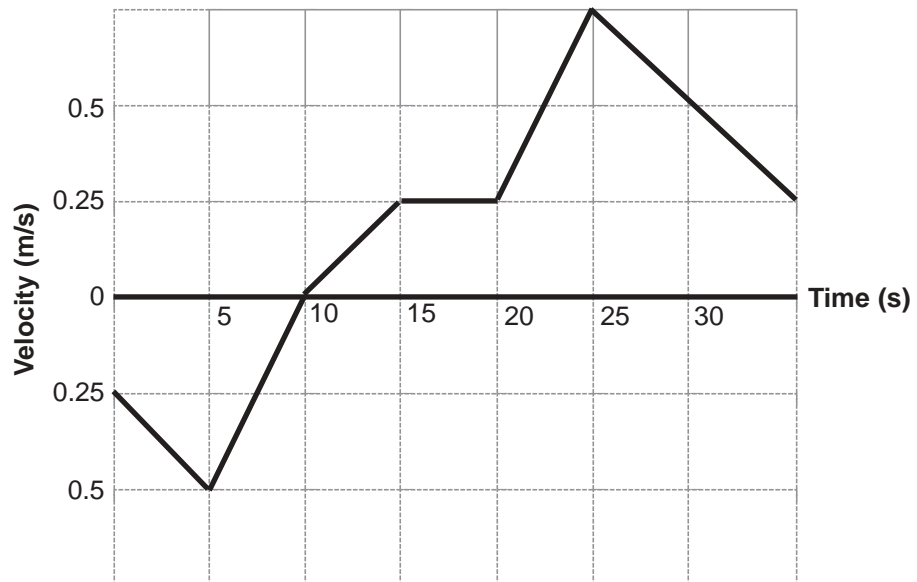

2. For the graph of velocity-time given above, plot a graph of position-time.
  - a) Make a table indicating how the positions were calculated.  
At  $t = 0$  s,  $x = 3.0$  m.
  - b) Plot the graph of position-time.



3. For the velocity-time graph used in Question #2, plot a graph of acceleration-time.
  - a) Make a table showing how the acceleration was calculated for each interval.
  - b) Draw the acceleration-time graph.
  - c) Determine the average acceleration between 5 s and 20 s.
  
4. A Corvette can accelerate from a dead stop to 100 km/h in 10.2 s.
  - a) Determine the acceleration of the car in m/s/s.
  - b) How far did the car travel during this time?
  
5. A sprinter accelerates from rest to a velocity of 9.25 m/s while travelling 25.0 m. The sprinter then runs at a constant velocity for the next 75.0 m.
  - a) Determine the time it took for the sprinter to reach a speed of 9.25 m/s.
  - b) How long did it take the sprinter to run the 100 metres?
  
6. You are driving your car at 15.8 m/s E as you approach an intersection. Having good reflexes, it takes you 0.450 s to react and step on the brakes. The brakes cause the car to accelerate at 8.50 m/s/s W.
  - a) What distance will the car travel during the braking before it slows to 10.8 km/h E?
  - b) What is the time interval during which the car is brought to a stop?



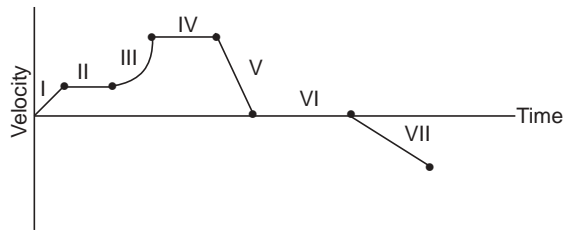

**SLA**Student  
Learning  
Activity**Appendix 3.13: Kinematics Sampler: Graphs, Equations, and Problem Solving**

1. The graph above represents the velocity as a function of time for an object that is moving back and forth along a straight line.
  - a) For each interval:
    - i) indicate whether the velocity is positive, negative, or zero.
    - ii) indicate whether the velocity is steady, increasing at a steady rate, increasing at a rate that is not steady, decreasing at a steady rate, decreasing at a rate that is not steady.
    - iii) indicate whether the acceleration is positive, negative, or zero.
  - b) Over which interval would the object travel through the greatest distance? Assume that each segment of the graph lasts for the same amount of time. Explain your answer.

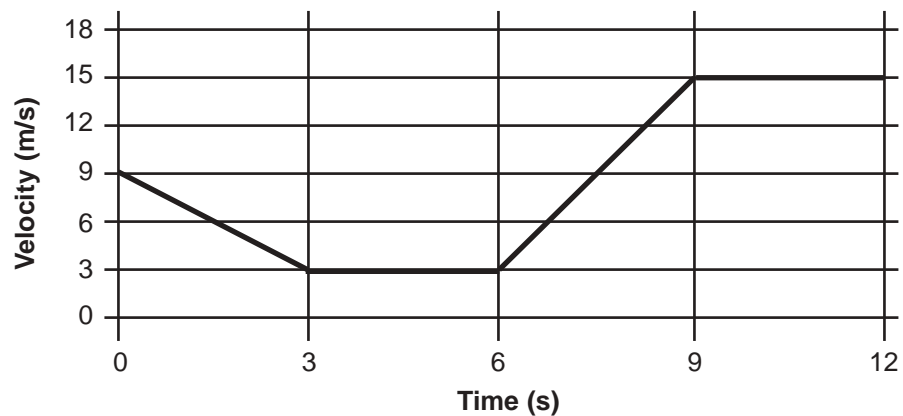

2. The graph above represents velocity as a function of time for an object moving back and forth along a straight line.
  - a) Plot a graph of acceleration versus time for this object.
  - b) Plot a graph of position versus time for this object.



3. A ball is thrown to the floor, bounces, and returns to the thrower's hand. Sketch graphs showing the position of the ball as a function of time, the velocity of the ball as a function of time, and the acceleration of the ball as a function of time. Assume that the ball is in contact with the ground for a negligible time interval and that the ball rises off the ground with the same speed it had when it first hit the floor. Assume upward to be the positive direction and the ground to be the zero point.
4. The table below shows the velocity of a car at various times. By looking at the table, but without substituting into any formulas, determine the acceleration of the car. Explain your answer in words.

Time (seconds)	Velocity (m/s)
0.0	2.5
1.0	3.2
2.0	3.9
3.0	4.6
4.0	5.3
5.0	6.0

5. A car has an initial speed of 16.7 m/s and accelerates at 2.5 m/s<sup>2</sup> for another 8.1 seconds. What is the final speed of the car?
6. A car is initially moving at 28.4 m/s. In a panic stop, the car can decelerate (slow down) with an acceleration of -3.8 m/s<sup>2</sup>. (The acceleration is negative because the car is slowing down.) What is the least amount of time it will take for this car to come to rest?
7. A car moving with a uniform (constant) acceleration takes 3.5 seconds to accelerate from 22 m/s to 34 m/s. Through what distance does the car move during this period of acceleration?
8. What acceleration must a car have if, starting from rest, it travels 30 metres in 3.5 seconds?
9. A rocket is blasting off with a constant upward acceleration of 18.7 m/s<sup>2</sup>. Through what vertical height will the rocket rise as its speed changes from 3.6 m/s to 8.5 m/s?
10. A sprinter running at a speed of 12.5 m/s is approaching the finish line and, in a final burst of willpower, she forces herself to accelerate over the last 3.5 metres of the race. If this period of acceleration lasted for a time interval of 0.24 seconds, what was the sprinter's speed as she crossed the finish line?



11. A motorist is driving at a speed of 32 m/s on a stretch of highway where the speed limit is equivalent to 25 m/s. A truck coming in the opposite direction is flashing its headlights, which the speeding motorist interprets as a signal that a police cruiser is hiding just around a bend in the road 20 metres ahead of the motorist's current location. What must the car's acceleration be (assuming it is constant) if the car is to slow down to the speed limit just as it rounds the bend and passes the police cruiser?
12. A car initially moving at 17.1 m/s undergoes a 2.5-s period of constant acceleration during which it travels 63.5 metres. At what rate was the car accelerating?
13. A baseball pitcher throws a fastball at a speed of 47 m/s. When the catcher receives the ball, he pulls his hand back through a distance of 0.35 metres in the process of making the catch. What was the acceleration of the ball as it was being caught, assuming that the acceleration was constant?
14. A car is moving at 26.5 m/s when the driver sees a red light. If the driver takes 0.45 seconds to step on the brakes and the braking causes the car to accelerate at  $-8.5 \text{ m/s}^2$ , through what distance will the car travel as it comes to rest?
15. An elevator starts from rest at the ground floor of a building and rises to the top floor without stopping anywhere in-between. The elevator accelerates at  $1.5 \text{ m/s}^2$  for 5 s, continues for an additional 15 s at the speed that it had after its initial period of acceleration, and then takes 1.8 s to come to rest with a uniform deceleration.
  - a) Through what vertical distance does the elevator rise during its initial period of acceleration?
  - b) What is the speed of the elevator after it stops accelerating?
  - c) Through what vertical height does the elevator rise during the period that it is moving at a constant speed?
  - d) Through what vertical height does the elevator rise during the time it takes to come to rest at the top of the building?
  - e) Through what total vertical height has the elevator risen?
16. The acceleration of an object due to gravity near the surface of the Moon is approximately  $1.6 \text{ m/s}^2$  and there is no air friction on the Moon. An astronaut throws a rock vertically upward on the lunar surface. What is the acceleration of the rock when
  - a) it is still rising?
  - b) it is at its highest point?
  - c) it is falling back to the lunar surface again?



17. The graph below shows velocity versus time for a car that is initially moving northward along a straight north-south road. Answer the following questions based on this graph.

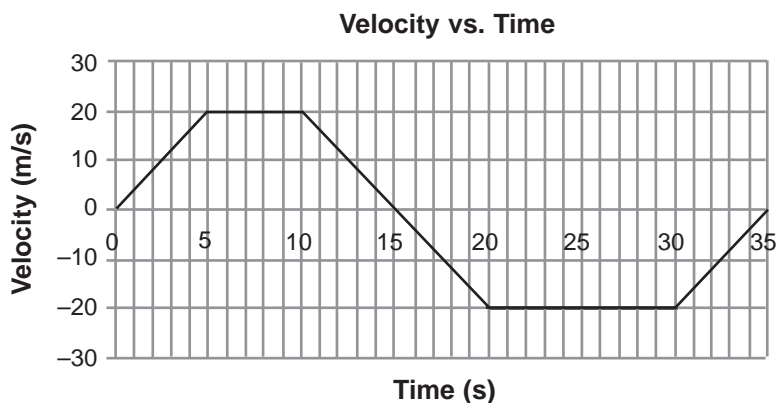

- At what time, after it starts out, does the car first reach its maximum speed in the northward direction?
- At what time, after it starts out, does the car first begin to slow down?
- At what time, after it starts out, does the car reach its maximum distance north of its starting point?
- At what time does the car first start heading back south again?
- Does the car ever come to rest after it has begun to head south again? If so, at what time?
- Is there any time interval during the 35 s shown on this graph during which the car begins to head back north again after it first began heading south? If so, what is the interval?
- At the 35-s mark, is the car at its starting point, north of its starting point, or south of its starting point? Explain how you reached your conclusion. (You should be able to arrive at the answer just by looking at the pattern of the graph and without doing a detailed numerical calculation.)
- What is the maximum distance the car goes north of its starting point?
- At what time, after it starts out, does the car first return to its starting point?
- Draw a graph of the car's displacement versus time.
- Draw a graph of the car's acceleration versus time.



18. The figure below is a graph of acceleration versus time for an object that is moving along a straight east-west path. At time  $t = 0$  s the velocity of the object is also zero, and we are assuming east to be the positive direction.

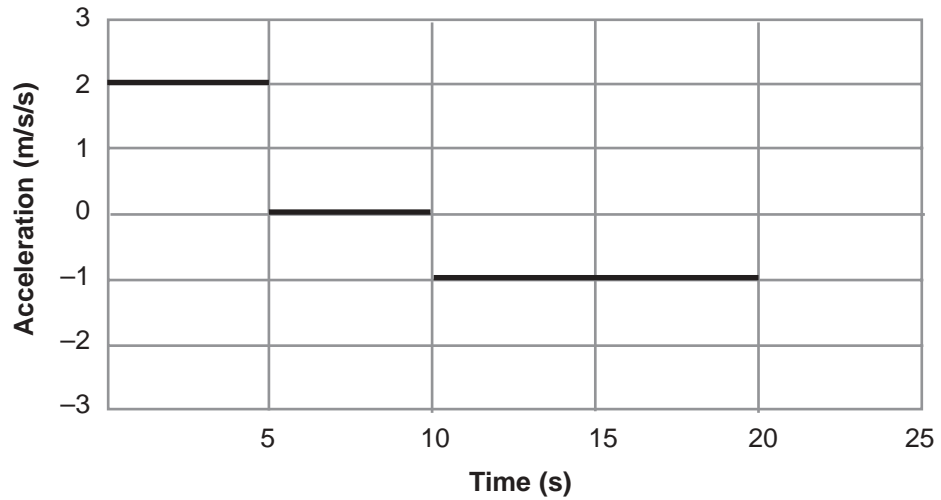

- Use a piece of graph paper with carefully numbered and labelled axes to draw a graph of velocity versus time for this object.
- Find the displacement of the object (with respect to its starting point) at 20 s. Be sure that you give a direction as well as a magnitude. Use the area under a velocity-time graph method rather than the kinematic formulas.
- Now assume that, rather than starting from rest, the initial velocity of the object was 4 m/s. Redraw the velocity-versus-time graph under this new assumption.
- Based on the new graph, calculate how many additional metres are added to the magnitude of the displacement at 20 s because of this change in the initial velocity. Notice that you should be able to calculate the change in the displacement without first calculating the new displacement. Explain how you can do this.



### Appendix 3.14: Kinematics Graphs Transformation Organizer

Going Down:  
Take Slopes

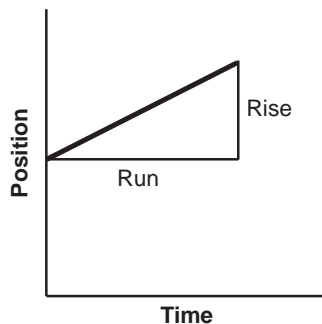

Run	Rise	Slope
Time Interval	Displacement	Velocity
(s)	(m)	(m/s)



	Area = $(V)(\Delta t)$	$d_f = d_i + \Delta d$
Time Interval	Displacement	Position at End of Interval
(s)	(m)	(m)

Area under V-T gives P-T graph.

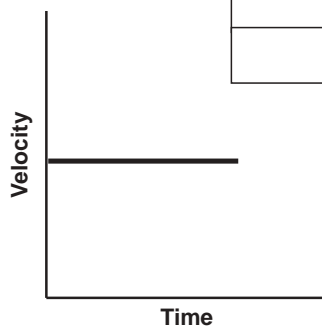

Run	Rise	Slope
Time Interval	Change in Velocity	Acceleration
(s)	(m/s)	(m/s/s)



	Area = $(a)(\Delta t)$	$v_f = v_i + \Delta v$
Time Interval	Change in Velocity	Velocity at End of Interval
(s)	(m/s)	(m/s)

Area under A-T gives V-T graph.

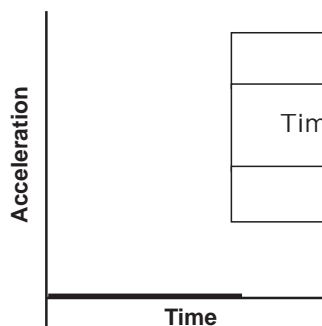

Going Up:  
Take Areas



**SLA**

Student  
Learning  
Activity

## Appendix 3.15: Journal Entry: Dynamics and Diagrams

### Part A

- Using the Three-Point Approach Frame, define and illustrate the following terms.

Dynamics

Force

Newton

Free-body diagram

Inertia

Unbalanced force

Inertia of rest

Inertia of motion

Applied force

- Use a Category Concept Map to relate the quantities in Newton's Second Law,  $F_{\text{net}} = ma$ .

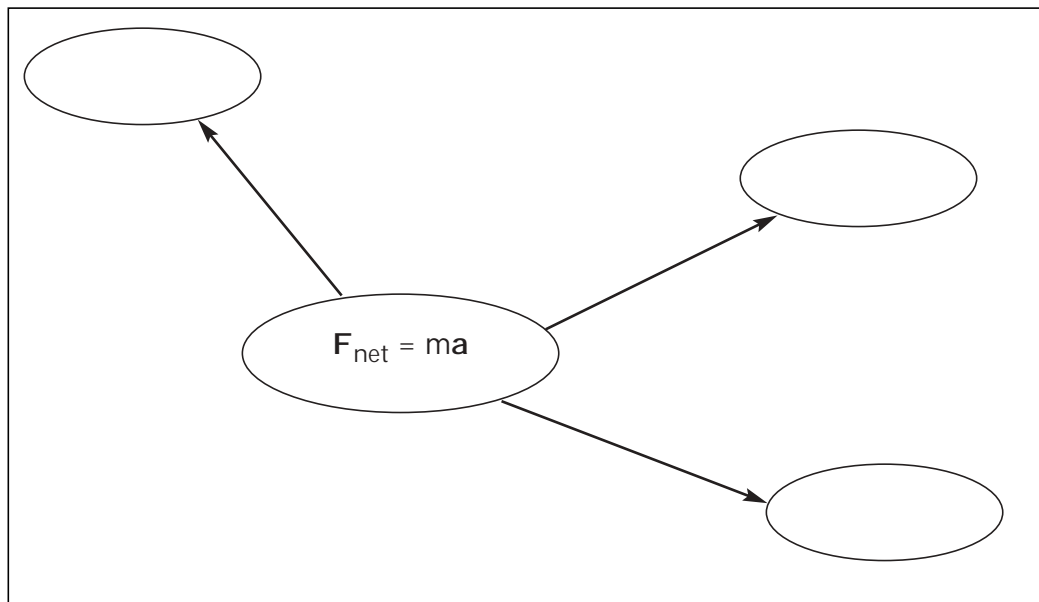

- Use a Compare and Contrast Frame to compare and contrast the following:
  - gravitational mass and inertial mass
  - mass and weight
  - normal force and force of friction
- Explain your strategy for solving problems that contain both kinematics and dynamics information.



## Part B









- Use Newton's Laws of Inertia to explain the following.
  - A person dressed for the winter is standing outdoors in the middle of a pond on frictionless ice. What would the person do, without help from anyone else, in order to reach the shore?
  - A car is driving on an icy road. It tries to turn around a curve but continues in a straight line and ends up in the ditch.
  - You are riding on a bus that is moving at 5 m/s south. You toss a coin straight upwards into the air. You do not move your hand. The coin lands in your hand.
  - According to a legend, a horse, having studied physics, learned Newton's laws. When it was told to pull a cart, it refused, saying that if it pulled the cart forward, according to Newton's Third Law, there would be an equal but opposite reaction force. Thus, there would be balanced forces acting on the cart and, according to Newton's Second Law, the cart would not accelerate. How would you reason with this horse?
- A horizontal force of 75.0 N accelerates a person on a skateboard, with total mass of 65.0 kg, at 0.900 m/s/s.
  - What is the net force acting on the skateboard and its rider?
  - Draw a free-body diagram of this situation.
  - What is the force of friction in this case?
- Two forces act on a sled of mass 80.0 kg. One force of 125 N acts in a southerly direction. A second force of 175 N acts in a westerly direction. The sled is pulled over a level snow-covered surface and accelerates at 1.50 m/s<sup>2</sup>.
  - Draw a free-body diagram showing the view from the top.
  - What is the net force accelerating the sled?
  - What is the sum of the two given forces?
  - What is the force of friction on the sled?
  - If the sled starts from rest, what is the displacement during the first 3 seconds?
- A force of 50.0 N acting 35° from the horizontal is pulling a toboggan and passenger, total mass of 50.0 kg, along a level snow-covered surface. From rest, the toboggan moves 5.00 m in 3.5 s.
  - Calculate the acceleration.
  - What is the net force pulling the toboggan forward?
  - Draw a free-body diagram (side view).
  - Determine the force of friction.

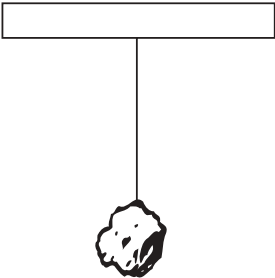

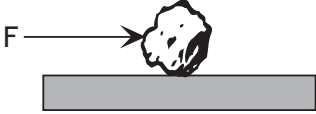

**BLM**Blackline  
Master**Appendix 3.16: Free-Body Diagrams: Linear Motion**

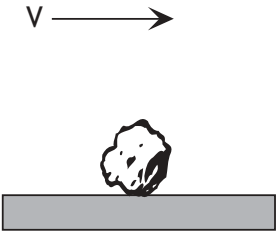
In each case in the pictures below, the rock is acted upon by one or more forces. All drawings are in the vertical plane, and friction is negligible except where noted. Draw accurate free-body diagrams showing all forces acting on the rock. Draw all forces as though they were acting on the centre of mass, even though forces like friction and the normal force act on the surface at the point of contact. Use a ruler and pencil so that you can correct errors. Label the forces using  $F_g$  for the weight or force of gravity,  $T$  for tension,  $F_f$  for force of friction, and  $F_N$  for normal force.



<p>1. Equilibrium</p> 	<p>2. Equilibrium</p> 	<p>3. Rock is pushed but remains motionless. Friction acts.</p> 
<p>4. Rock is falling, no friction.</p> 	<p>5. Rock is sliding at constant speed on a frictionless surface.</p> 	<p>6. Rock is falling at a constant (terminal) velocity.</p> 
<p>7. Rock is decelerating because of kinetic friction.</p> <p><math>v \rightarrow</math></p> 	<p>8. Rock is rising. No friction.</p> 	<p>9. Rock is at the top of its flight, momentarily motionless.</p> 



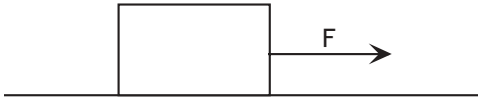

### Appendix 3.17: Free-Body Diagrams 2: Linear Motion

In each case in the pictures below, the block is acted upon by two or more forces. All drawings are in the vertical plane, and friction is negligible except where noted. Draw free-body diagrams showing all forces acting on the block. Draw all forces as though they were acting on the centre of mass, even though forces like friction and the normal force act on the surface at the point of contact. Use a ruler and pencil, so that you can correct errors. Label the forces using  $F_g$  for the weight or force of gravity,  $F_f$  for force of friction, and  $F_N$  for normal force.

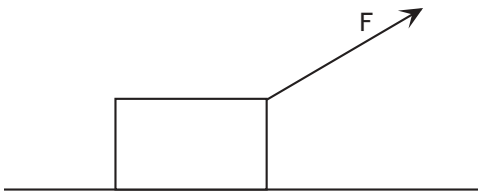
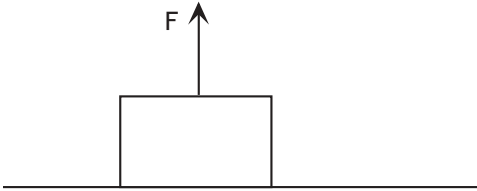
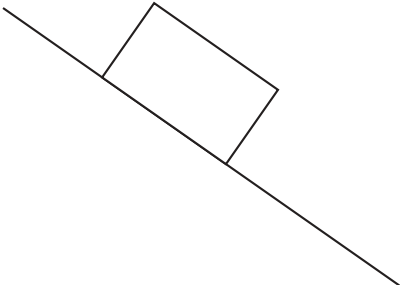
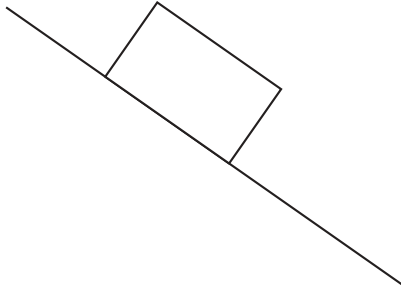
<p>1. The object is pulled horizontally. No friction.</p> 	<p>1. The object is pulled horizontally at constant velocity. Kinetic friction acts.</p> 
<p>3. The object is pulled by a force acting in the direction shown. Static friction acts. The object is motionless.</p> 	<p>4. The object is pulled straight upwards. It is motionless.</p> 
<p>5. The object is resting on the plane. No friction acts.</p> 	<p>6. The object remains motionless. Static friction acts.</p> 



## APPENDIX 4: FIELDS

**SLA**  
Student  
Learning  
Activity

### Appendix 4.1: Vertical Motion at the Earth's Surface

For these questions, use  $g = -9.80 \text{ m/s}^2$ . Assume that air friction is negligible.

1. A stone is dropped from a bridge to the water below. If it takes 2.45 s for the stone to hit the water, calculate the distance the stone fell.
2. A baseball is popped straight up. The ball leaves the bat moving at 37.8 m/s.
  - a) How long does the catcher have to get in position to catch the ball at the same height as the bat struck the ball?
  - b) To what height did the ball rise?
  - c) At what time, after being struck, is the ball moving at 10.0 m/s upwards? Where is the baseball at this time?
  - d) At what time, after being struck, is the ball moving at 10.0 m/s downwards? Where is the baseball at this time?
  - e) What is the velocity of the ball when it is caught?
  - f) At what time is the ball 20.0 m above the ground?
  - g) Where is the ball 4.19 s after being hit?
3. An astronaut on the Moon accidentally drops a camera from a height of 1.60 m.

$$g_{\text{moon}} = -1.62 \text{ m/s}^2$$

- a) How long will it take before it strikes the lunar surface?
  - b) If the astronaut were training on Earth, how long does it take for the fall?
  - c) How fast is it moving when it strikes the surface of the Moon?
4. Food aid on a skid is dropped from an airplane flying horizontally at 125 m/s. The food skid falls for 18.6 s before it hits the ground.
    - a) From what height was the food dropped?
    - b) What is its vertical velocity when it strikes the ground?
    - c) How fast is it travelling horizontally when it strikes the ground?
    - d) How far did the food fall during the fifth second after being released?



**Problem Set Answer Key:**

1. -29.4 m
2.
  - a) 7.72 s
  - b) 73.0 m
  - c) 67.9 m
  - d) 67.8 m
  - e) -37.8 m/s
  - f)  $t_1 = 0.571 \text{ s}$      $t_2 = 7.14 \text{ s}$
  - g) 72 m above the ground
3.
  - a) 1.405 s
  - b) 0.927 s
  - c) -3.45 m/s
4.
  - a) 630 m
  - b) -183 m/s
  - c) 125 m/s in original direction of motion
  - d) -44 m (44 m downwards)



**SLA**Student  
Learning  
Activity**Appendix 4.2: Journal Entry: Gravitational Fields**

- Complete the Three-Point Approach for the following terms.
  - gravity
  - field
  - force of gravity
  - weight
  - gravitational field
  - $g$
  - altitude
  - latitude
  - free-body diagram
  - acceleration due to gravity
  - weightlessness
  - mass
- Gravity is the major concept in this section. Putting gravity at the centre, draw a Concept Map showing how all the terms in Question #1 fit into your scheme for understanding gravity.
- A stone of mass 75.0 g is dropped from the top of a 10-storey building with a height of 32.1 m. Calculate:
  - the velocity with which the stone hits the sidewalk below.
  - the time elapsed from the instant the stone is dropped until it strikes the sidewalk.
  - the weight of the stone.
- From Question #3, calculate the velocity with which the stone hits the sidewalk if the stone was initially thrown upwards at 12.5 m/s.
- From Question #3, calculate the final velocity with which the stone hits the sidewalk if only a constant force of air friction of 0.4 N acted on the stone.
- Why is ' $g$ ' at a planet's surface different for different planets?
  - What kind of planet would have about the same value of  $g$  at its surface as Earth? Justify your answer based on your ideas from Part A.





### Appendix 4.3: Student Sampler: Magnetic Fields

1. Given a bar magnet and an unmagnetized piece of iron that to the naked eye seem identical, describe how you would determine which object is magnetized:
  - a) using a third object of your choice.
  - b) using only the two objects.
2. Describe how a piece of iron can be made into a permanent magnet. Describe the process used outside the magnet and describe what is happening inside the magnet.
3. What is a domain?
4. Describe what happens if a bar magnet is cut into three equal lengths.
5. In the diagrams below, each circle represents a compass. Show the direction of the needle in each compass.

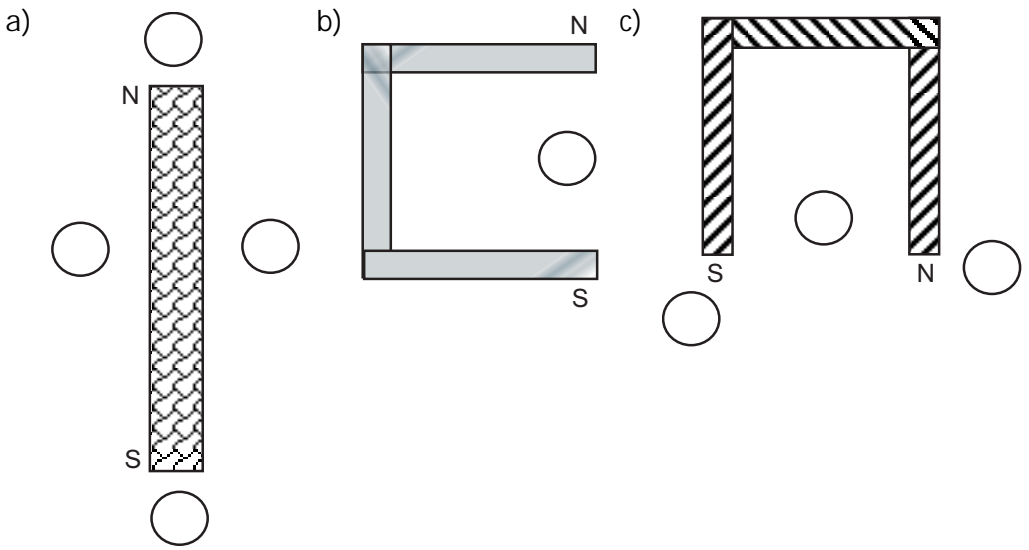

6. What is an **angle of declination**? What implication does it have in the use of a compass?
7. Sketch the magnetic field around
  - a) a bar magnet
  - b) the poles of a horseshoe magnet
  - c) two north poles pushed close together
  - d) Earth



8. The pointed end of an iron nail is held close to the 'S' pole of a magnet.
  - a) Which end of the nail becomes 'N'?
  - b) Name the process that makes the nail a temporary magnet.
9. Apply the domain theory to explain each of the following:
  - a) A nail can be magnetized by stroking it with a strong permanent magnet.
  - b) When a magnet is being magnetized, it reaches a point called saturation where it cannot become any stronger.
  - c) A magnet can be demagnetized by being hammered repeatedly.
  - d) An iron magnet can be demagnetized by being heated to  $770^{\circ}\text{C}$ .
10. In terms of magnetic properties, distinguish between soft iron and hard iron.
11. Name the three most important magnetic chemical elements. What is it in these atoms that makes them magnetic in nature?
12. Distinguish among ferromagnetic, paramagnetic, and diamagnetic materials.





## Appendix 4.4: Student Article Analysis—Scientific Fraud?

### Flirting with Fraud:

#### Millikan, Mendel and the Fringes of Integrity

by Douglas Allchin (1992)

Fraud in science has deluged the public lately: with the David Baltimore/Immanishi-Kari case, cold fusion (Pons and Fleischmann), and allegations against Gallo's priority claims in discovering the AIDS virus. And, with the reporting system in the Human Genome Project being largely unmonitored, can we expect new charges of abuses to be far behind? Many universities, following guidelines established by NSF, now have committees on "scientific integrity," and NSF has sent investigative teams to spot check some of the more active research institutions receiving federal funds.

The depth of fraud historically has been documented (though still quite incompletely) by journalists William Broad and Nicholas Wade in their 1982 *Betrayers of the Truth* (includes an appendix summarizing 34 cases). But careful examination of these cases can also pose some provocative questions about "proper" science. Consider, for example, the classic case of Gregor Mendel, whose published data on inheritance in pea plants, according to statistician Fisher, were too good to be true. Mendel's results were a one in a million chance. Some defend Mendel, though, saying that he followed contemporary practice: to repeat experiments, refine own's technique, and then use only the best results as the most representative ones. If that is not legitimate now, why not? What does this reveal about how we evaluate evidence? It is worth noting for ourselves, in fact, that the standards themselves have changed. Why?

A question worth posing for discussion is:

If a scientist gets the "right" answer, does it matter if the data were "tweaked," "massaged," distorted, or even wholly fabricated?

The case of Robert Millikan, whose renowned oil-drop experiment established the value of the fundamental unit charge,  $e$  (and earned him the Nobel Prize in 1923), is far more provocative.

Millikan, of course, kept detailed notebooks of his laboratory activities, data and assessments of results. Several years ago, an effort to reconstruct Millikan's "exemplary" experimental thinking revealed serious discrepancies between Millikan's notebooks and his published "raw" data (Holton, 1978). The numerous notes which are scattered across the pages cast further doubt on Millikan's integrity:

*This is almost exactly right & the best one I ever had!!!* [20 December 1911]

*Exactly right* [3 February 1912]

*Publish this Beautiful one* [24 February 1912]

*Publish this surely/Beautiful!!* [15 March 1912, #1]

*Error high will not use* [15 March 1912, #2]

*Perfect Publish* [11 April 1912]

*Won't work* [16 April 1912, #2]





*Too high by 1½% [16 April 1912, #3]*

*1% low*

*Too high e by 1¼%*

Millikan had apparently been calculating the values of  $e$  for each set of observations as he went along, and comparing them with his expected value. Further, he seemed to use the match with the theory that he was supposedly testing as a basis for including or excluding results as the very evidence for that theory! As Franklin (1986) has noted, “we are left with the disquieting notion that Millikan selectively analyzed his data to support his preconceptions” (p. 141; echoing Holton 1978). Are we to conclude that Millikan’s analysis, laden with theoretical bias and which seems to treat experimental facts so casually, reflects the nature of scientific “genius”?

The notebooks reveal that, indeed, substantial data are missing from Millikan’s published reports. Of 175 total drops documented in the notebooks, only 58 (barely one-third) appear in the final paper. By contrast, Millikan had announced in his 1913 paper that “It is to be remarked, too, that this is not a selected group of drops but represents all of the drops experimented on during 60 consecutive days, during which time the apparatus was taken down several times and set up anew.” In his 1917 book, *The Electron*, he repeats this statement and then adds, “These drops represent all of those studied for 60 consecutive days, no single drop being omitted.”

At first blush, this outrageous violation of scientific integrity would seem to discredit Millikan’s findings. Even if one assumes that standards of reporting data earlier in the century were less rigorous, Millikan clearly misrepresented the extent of his data. One may caution, however, that we may not want to conclude that therefore there was no good, “scientific” basis for his selective use of data. A more complete analysis of Millikan’s notebooks, in fact, and of the nature of the experimental task that they crudely document, reveals more tellingly the reasons that Millikan included some drops and excluded others.

Physicist-philosopher Allan Franklin has addressed the problem by using Millikan’s original data to recalculate the value of  $e$ . Even when one uses various constellations of the raw data, Millikan’s results do not change substantially. That is, their accuracy was not severely affected by Millikan’s choice of only a subset of the observations. Millikan’s selectivity, at most, gave a false impression of the variation in values or the range of “error” in the data and, therefore, of the statistical precision of the computed value.

In fact, Franklin notes, Millikan threw out data that were “favorable” as well as “unfavorable” to his expectations. Clearly, Millikan’s results were over-determined. That is, he had more data than he needed to be confident about his value for the electron’s charge. Here, the redundancy of data was an implicit method for safeguarding against error. Thus, what appears as fraud from one perspective becomes, from an experimental perspective, a pattern of good technique.



One may examine further specifically when the observations that Millikan excluded occurred. The first 68 observations, for instance, were omitted entirely. Why? Following February 13, 1912 (which marks the first published data), one may also note, the number of excluded results decreases as the series of experiments proceeds. Apparently, Millikan became more skilled as time went on at producing stable, reproducible data. Prior to February 13th, one may infer, he was still working the “bugs” out of the apparatus and gaining confidence in how to produce trustworthy results. That is, he was testing his equipment, not any theory of the electron or its charge. Here, the notebooks help focus our attention on the apparatus and the material conditions for producing evidence, not the role of the evidence itself.

Millikan’s comments in the notebooks highlight the significance of experimental judgements, especially in excluding particular observations. For example, “Beauty Publish,” on April 10, 1912 is crossed out and replaced by, “Brownian came in.” Here, the way the drop had moved meant that his measurements did not reflect the values Millikan needed for his calculations—those which the apparatus, of course, was specifically designed to produce. Millikan’s judgement about other aspects of the experimental set-up are revealed elsewhere:

*This work on a very slow drop was done to see whether there were appreciable convection currents. The results indicate that there were. Must look more carefully henceforth to tem[perature] of room. [19 December 1911]*

*Conditions today were particularly good and results should be more than usually reliable. We kept tem very constant with fan, a precaution not heretofore taken in room 12 but found yesterday to be quite essential. [20 December 1911]*

*Possibly a double drop. [26 January 1912]*

*This seems to show clearly that the [electric] field is not exactly uniform, being stronger at the ends than in the middle. [27 January 1912]*

*This is good for so little a one but on these very small ones I must avoid convection still better. [9 February 1912]*

*This drop flickered as tho unsymmetrical. [2 March 1912]*

*This is OK but volts are a little uncertain and tem also bad. It comes close to lower line. [7 March 1912, #1]*

Millikan had thus been concerned about several parameters critical for obtaining “good” or “clean” results, consistent with the design of the experiment: the size and symmetry of the drop; convection currents (temperature of room); smoothness of movement of the drop; and (elsewhere) dust, pressure and voltage regularity (Franklin, pp. 149-50).



Even where he could not pinpoint the problem, he might sense that “something the matter . . .” [13 February 1912]. Millikan’s confidence in his judgement meant that in some cases he did not even go on to calculate  $e$ , excluding those observations even before seeing the “results.” In other cases, he recognized the “beauty” of the run:

*Beauty. Tem & cond's perfect. no convection. Publish* [8 April 1912]

Millikan’s decisions to publish data (or not) based on their “beauty” (above), therefore, probably reflected his assessments of the particular experimental conditions. His striking comment on February 27, 1912, “Beauty one of the very best,” may thus refer, not to the value of  $e$  itself, but to the quality of his own technique.

Millikan excluded other events based on the methods of calculation. For example, the formula used a substituted value based on certain theoretical assumptions in Stokes’s Law (relating pressure, air viscosity and drop radius). While Millikan tolerated the first-order “corrections” for the values, in 12 cases where unusual data required him to rely on less certain second-order corrections, he simply omitted the events. In other words, not all data were “user-friendly”—that is, tailored to the framework for drawing legitimate conclusions.

Millikan was also able to exploit the fact that the value of  $e$  could be calculated in two ways, each using slightly different measurements of the same event. He allowed the two methods to cross-check each other. In some cases, he noted:

*Agreement poor. Will not work out.* [17 February 1912, #3]

*Error high will not use. . . . Can work this up and prob is OK but point is not important. Will work if have time Aug. 22* [15 March 1912, #2]

Again, where he found discrepancies, he was better off avoiding the possible uncertainties by simply sidestepping the “unworkable” events. By the end of the experimental period, one can sense that Millikan, having more than enough data, was continuing his work merely to build confidence about all his safeguards. Three days before he stopped taking observations, he satisfied himself, “Best one yet for all purposes” [13 April 1912]. Two days later, the very day before ending, he recorded:

*Beauty to show agreement between the two methods of getting  $v_1 + v_2$  Publish surely* [15 April 1912]

An aim of internal consistency, rather than agreement between theory and data, clearly guided Millikan’s work.



Even the final values of the calculations could themselves be clues or signals that something was amiss. One erratic value of  $e$ —clearly outside the boundary of typical or “reasonable” values, or of anything else he had found to date—prompted Millikan to decide: “could not have been an oil drop” [20 December 1911 #3], and to conclude apparently that it was a dust particle. Millikan excluded two other important drops that gave anomalous values of  $e$ , even though one, by Millikan’s own judgement, was a model of consistency. Having begun with some confidence:

*Publish. Fine for showing methods of getting  $v$*  [16 April 1912, #2]

He later marked in the corner of the page (without further accounting), “Won’t work.” In retrospect, Millikan’s intuition seemed to have served him well: we know from data in Millikan’s notebook that these two drops had unusually high total charges and that such drops (as we have learned since 1912) are not reliable using the method that Millikan used. Here, again, Millikan’s primary reasoning concerned whether to trust the apparatus and his experimental measurements—not (yet) whether the theory or value of  $e$  itself was correct.

The use of Millikan’s oil drop experiment in class labs can easily suggest to students that it was quite trivial—what with a novice being able to reproduce the work of a Nobel Prize winner, after all! The current standardization of the experiment disguises, though, the complexity of the context in which it developed. Conceptually, the task in the early 1900s was relatively clear. Indeed, Millikan’s experimental strategy in 1910-1912—to observe drops of fluid, each laden with charge, moving in an electric field—had been tried by many researchers before. The chief difficulties at the time lay in the mechanics of constructing the situation idealized by theory. Millikan’s ultimately successful strategy differed from others by focusing on single drops and by substituting water with oil, which did not evaporate so easily and thus made more sustained observations possible. That is, Millikan’s achievement, marked by the Nobel Prize, was largely technical.

An analysis of Millikan’s notebooks, therefore, highlights a grey zone between outright misrepresentation of data and skilled experimental “micro-reasoning.” Was Millikan’s selective use of data “good” science? One may contrast Millikan and his success, in this case, with his critic, Felix Ehrenhaft, who stubbornly resisted discarding the results of any run. Was Ehrenhaft’s experimental posture appropriately conservative or unduly myopic? Was Millikan, likewise, inexcusably dishonest or justifiably pragmatic?

The question of whether editing of data can represent good science is obviously aggravated by cases where they have failed to yield reliable conclusions. Stephen Jay Gould (1981, pp.56-60) notes that in studying the relative cranial capacity of Caucasians and “Indians,” a 19th-century investigator excluded many Hindu skulls...but for “good” reasons? The “Hindoo” braincases were too small and, because they were “clearly” unrepresentative of the Caucasian population he wanted to sample, they would “bias” his results. Here the effect of



the selection was probably not even conscious. Likewise, anthropologists in the same era, evaluating women's skulls, relied on their "intuitions" to disregard types of measurements that suggested that women (or elephants, whales or bear-rats) were more intelligent than men. So, can one know where selection is legitimate, and where not?

The cases of Millikan and Mendel illustrate, in particular, that in answering such a question, we must focus on experimental skills and judgement (and on apparatus) as much as on the concepts themselves. While this is the potential "lesson," though, the problem that sparks the inquiry may be the spectre that fraud is the very tool of genius.

### **Further Reading**

- Fisher, R.A. 1936. "Has Mendel's Work Been Rediscovered?" *Annals of Science* 1:115-137. Reprinted in C. Stern and E. Sherwood (eds.), *The Origins of Genetics: A Mendel Source Book* (W.H. Freeman, 1966).
- Franklin, Allen. 1981. "Millikan's Published and Unpublished Data on Oil Drops." *Historical Studies in the Physical Sciences* 11:185-201. Also discussed in Chap. 5 of *The Neglect of Experiment* (Cambridge Univ. Press, 1986).
- Gould, Stephen Jay. 1981. *The Mismeasure of Man*. W.W. Norton.
- Holton, Gerald. 1978. "Subelectrons, presuppositions and the Millikan-Ehrenhaft Dispute." *Historical Studies in the Physical Sciences* 9:166-224. Reprinted pp. 25-83 in *The Scientific Imagination* (Cambridge Univ. Press, 1978).

"Flirting with Fraud: Millikan, Mendel and the Fringes of Integrity" by Douglas Allchin. Copyright © 1992. Reprinted from <ships.umn.edu> by permission. All rights reserved.



**SLA**  
Student Learning Activity

### Appendix 4.5: William Gilbert and the Earth’s Magnetic Field

“... magnetick force is animate, or imitates life: and in many ways surpasses life which is bound up in the organick body.”

William Gilbert (1600)  
from his *Physiologia Nova de Magnete*

Sir William Gilbert personifies the “Renaissance man” in that he had a wide-ranging set of interests, and ended up by making his greatest contributions outside of his chosen vocation—medicine. During the latter part of the 16th century, the separation between what was called “craft” (we would call it

technology) and “scholastics” (philosophical/intellectual work) was beginning to break down. There was no scientific method of enquiry as we have come to know it today—no experimental rigour, creation of theories, testing of hypotheses, theoreticians, et cetera. Nevertheless, the scholars of the day supplied the craftspeople with the theory they lacked. This is where William Gilbert made a noble contribution to natural philosophy (we call it “science”).

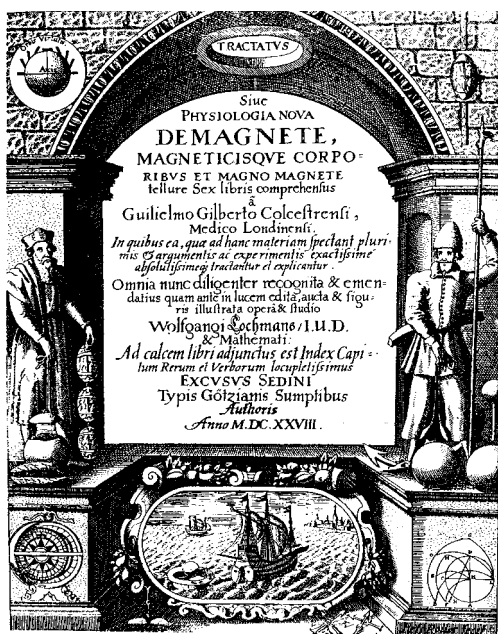

Building on the observations of a retired London mariner and compass-maker, Gilbert sought the answers to how magnetic materials functioned. Natural magnets—called “lodestones”—had been around since antiquity. Indeed, our word “magnet” derives from the Greek *ho Magnes lithos*, meaning “the Magnesian stone,” which were abundant in what is now northern Greece.

Gilbert, the court physician to Queen Elizabeth I, was fascinated with the experiments of Robert Norman (the compass-maker)—particularly those dealing with the magnetic inclination or the dip of a freely suspended compass needle. Gilbert fashioned spherical lodestones to which he gave the intriguing name *terrellas* (little Earths), and proceeded to demonstrate exhaustively any magnetic phenomena.

Among his many observations, Gilbert found that, like a mariner’s compass needle, small magnetic iron needles rested on the surface of a *terrella* with a dip angle related to the position of one of the magnetic poles (see his sketch on the following page).



“Variety in the Inclinations of Iron Spikes at Various Latitudes of a Terrella”

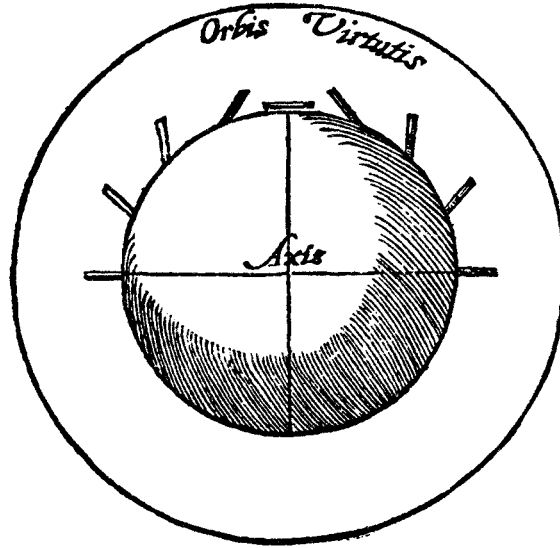

You may have noticed that Gilbert included an *orbis virtutis* (the sphere of virtue) above the surface of the *terrella*. He believed that the magnetic field of a lodestone was somehow coupled to the surface by what he called a *coition*. Later on, this *orbis virtutis* was to provide the force necessary to cause the Earth's diurnal (daily) rotation on its axis. The 13th-century writer, Pierre de Maricourt, had suggested that spherical magnetic bodies spontaneously rotate about their magnetic axes. Though he never saw this phenomenon, he declared openly:

“. . . the Great Magnet of the Earth turns Herself about by Magnetick and Primary virtue . . .”

From Gilbert's point of view, the Earth's magnetism reached to the heavens and was responsible for holding the Earth together. In Newtonian terms, then, terrestrial gravity was simply magnetism.

“. . . the magnetick diurnal revolution of the Earth's globe is a possible assertion against the time-honoured opinion of a Primum Mobile . . .”

With his magnum opus *de Magnete*, Gilbert ushered in a new era where empirical study and the theoretical interpretation of nature would merge in a novel way. Francis Bacon later pointed out that even though Gilbert conducted many “experiments,” his work was noticeably speculative. Instead of using his hypotheses to influence his experimental work, Gilbert formulated his theories after his experimental work had been completed and did not devise further investigations that would give substance to his conclusions. Despite these criticisms, Renaissance natural philosophy owes a great deal to this man's work—for he struggled with a reasoned approach to the visible universe. In the



sense that he tried to reconcile technology of the day to the high-minded principles of natural philosophy, Gilbert was indeed a “Baconian” in his methods, even if a certain naïveté existed in his procedures.

Perhaps his greatest insight was his vision of the Earth as a “great magnet” that was **dipolar**. By duplicating with his terrella many of the observations known from nautical experience, Gilbert was convinced that the Earth’s composition was similar to a great, spherical lodestone with two magnetically opposed poles. Sir William developed the view of the solid Earth as being like an enormous lodestone.

We know that the mineral **magnetite ( $Fe_3O_4$ )** predominates in his terrellas, and it is interesting that today most geophysicists support the idea that the Earth’s liquid, metallic outer core is composed primarily of iron and nickel with a solid iron inner core beneath it. Today, many are in agreement that the fluid motions in the Earth’s outer core are responsible for the generation of the magnetic field of the planet (the so-called **geodynamo**). It is remarkable to think that we still have a very poor understanding of the source of the Earth’s magnetic field, and work with modern-day “terrellae” to model fluid motions in the outer core.

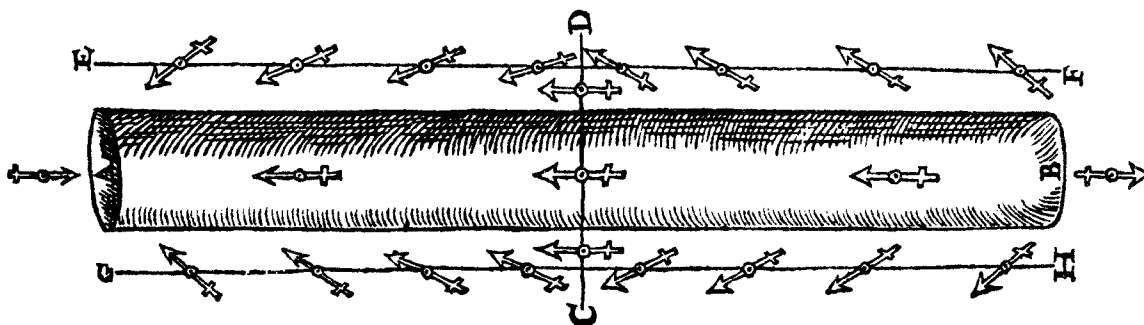

“ . . . a lodestone attracts magneticks not only to a fixed point or pole, but to every part of a terrella save the æquinoctial zone . . . ”

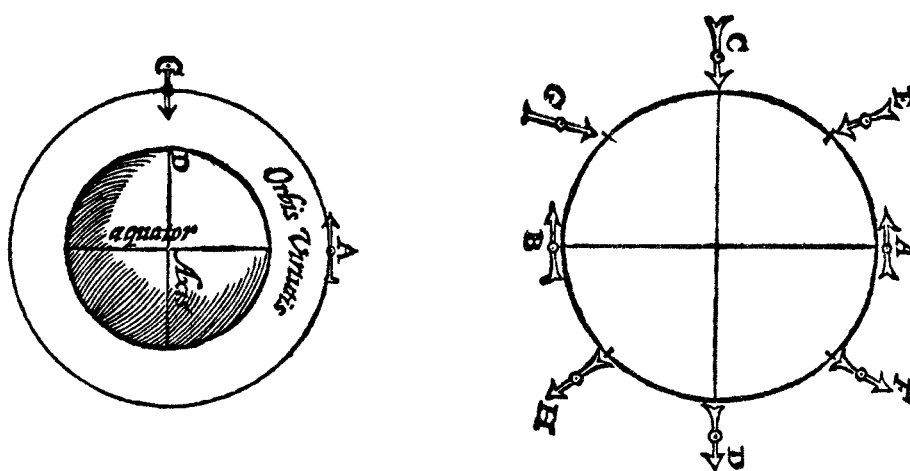



Since William Gilbert was a contemporary of Galileo Galilei, Johannes Kepler, and Tycho Brahe, it is not surprising that he had opinions about the large-scale structure of the universe and was familiar with these luminaries of the early 17th century. In fact, he adopted the Tychonian system that consisted of the five planets revolving around the Sun, and that this system in turn was in circular motion about a fixed Earth. There was one notable exception, however; Gilbert suggested that the Earth underwent diurnal rotation. Perhaps he had in mind that the magnetic field of the Earth was the motive force driving the entire cosmos!

“. . . for in the oldest mines of iron, the most famous at Magnesia in Asia, the lodestone was often dug out with its uterine brother, iron . . .”

The activities that follow are designed to aid the student in “discovering” the magnetic field of the Earth. Indeed, most were demonstrated by Gilbert himself. As the students make their way through each of them, encourage them to use brief sketches as much as possible along with observational statements. This may help to visualize a model of the Earth’s magnetic field that accounts for what they see.

### **Activity Sequence: Earth’s Magnetic Field**

#### **Activity 1: Magnetic Poles**

- Examine a bar magnet and notice that it is marked with an ‘N’ on one end and an ‘S’ on the other end. What do these letters mean?
- Suspend the bar magnet with a piece of dental floss so that it rests horizontally above the floor. Give the magnet a few turns, let go of it, and observe the direction the end marked ‘N’ points to when it comes to rest again.
- Repeat this at least three more times and make a statement about what you observed. Record all results carefully, and include sketches.

#### **Activity 2: Magnetic Compass Needle**

- Using the pivot-mounted compass needle, repeat the procedure from the previous activity. First, cause the needle to rotate on its pivot and record the direction of the pointer after it comes to rest.
- Make a statement about your findings, and compare with those from Activity 1.



### Activity 3: Nature of “Like” and “Unlike” Poles

- Using the suspended bar magnet, bring the ‘N’ pole of a second magnet near (but not touching) the ‘N’ pole of the suspended magnet. What do you see happening?
- Repeat this procedure for the ‘S’ pole of the test magnet (i.e., reverse the ends). What do you observe? Make a prediction about what will happen if you repeat these two steps at the ‘S’ pole of the suspended magnet.
- Test your predictions. Did you observe what was expected from your predictions?
- Make brief sketches and note your observations alongside your sketches. Are there any general conclusions that can be made from this activity?
- Using the small compass available, repeat the above steps and compare/contrast the observations with those using the bar magnet. Is there a certain behaviour for **magnetic poles** that is common to both sets of observations in this activity?

### Activity 4: Mapping a Magnetic Field

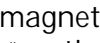
- This activity simulates one of the important observations of Sir William Gilbert, and encourages you to develop your own conception of how the Earth’s magnetic field should behave.
- Place a bar magnet on a sheet of large, white paper. Orient, if possible, the ‘N’ pole of the bar magnet with the magnetic north determined from Activities 1 and 2.
- Use a small magnetic compass for this procedure.
- Beginning near the ‘N’ pole and moving towards the ‘S’ pole at a distance of a few centimetres from the magnet, draw an arrow () to indicate the orientation of the “north-seeking” pointer on the compass. You should have at least eight to ten arrows for one complete circle around the perimeter of the bar magnet.
- Repeat this procedure, but at a distance of twice that used above. Attempt to draw the arrows in approximately the same locations so that straight lines drawn through them would meet at the centre of the magnet.
- Repeat a third time at a distance of four times that used on the first trial.
- Attempt to draw “magnetic lines of force” that would outline the structure of the magnetic field. Compare your results with William Gilbert’s original drawing shown on the following page. In what ways is your “map” similar to Gilbert’s map? Do you notice any differences between the two?
- Generalize the above results and draw a sketch of what you suppose the Earth’s magnetic field would look like if it were visible to the eye from space. As an interesting part of this, decide where you would put the ‘N’ and ‘S’ poles of the Earth’s internal magnet. Make sure that your model is able to explain all of the characteristics of a magnet that you have demonstrated so far.



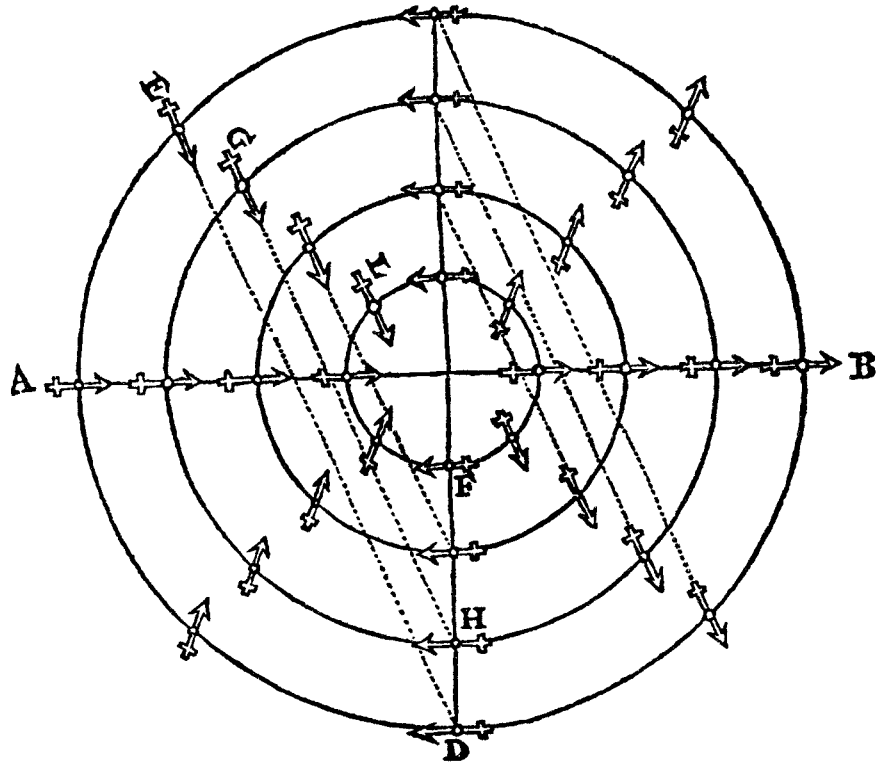

## NOTES



## APPENDIX 5: DEVELOPING ASSESSMENT RUBRICS IN SCIENCE

### The Nature, Purposes, and Sources of Assessment Rubrics for Science

#### What Assessment Rubrics Are

Rubrics are assessment tools that identify criteria by which student processes, performances, or products will be assessed. They also describe the qualities of work at various levels of proficiency for each criterion.

The following types of assessment rubrics may be used in classroom assessment:

- **General rubrics** provide descriptions of proficiency levels that can be applied to a range of student performance processes, performances, or products. Using the same rubric for similar tasks helps teachers manage marking assignments based on student choice, and helps students internalize the common qualities of effective processes, performances, and products.
- **Task-specific rubrics** describe the criteria used in assessing specific forms such as the use of a balance, writing a laboratory report, or calibrating CBL probes. Complex student projects may require a different rubric for each phase (for example, a group inquiry project may require a rubric for collaborative work, information-gathering processes, oral presentations, and written reports).
- **Holistic rubrics** are used to assign a single mark to a process, performance, or product on the basis of its adequacy in meeting identified criteria.
- **Analytic rubrics** are used to assign individual scores to different aspects of a process, performance, or product, based on their specific strengths and weaknesses according to identified criteria. See the Rubric for the Assessment of a Decision-Making Process Activity in Appendix 6.
- **Checklists** are lists of criteria that do not distinguish among levels of performance. They are used to assess the presence or absence of certain behaviours, and are most suitable for assessing processes (for example, “Did the student perform all the necessary steps?”). Because they require “Yes/No” judgements from the assessor, checklists are easy for students to use in peer assessment.
- **Rating scales** ask assessors to rate various elements of a process, performance, or product on a numerical scale. They do not provide complete descriptions of performance at various levels.

## Why Teachers Use Assessment Rubrics

The best assessment tasks ask students to perform the sorts of scientific literacy tasks they will be called upon to perform in real-world situations. They allow students to demonstrate not only the declarative knowledge they have gained, but also the interplay of attitudes, skills, and strategies that constitute their learning. Authentic assessment tasks invite a range of responses and allow students to express their individuality. For all these reasons, assessing scientific literacy is a complex matter.

Assessment rubrics:

- help teachers clarify the qualities they are looking for in student work;
- ensure that all students are assessed by the same criteria;
- help teachers communicate the goals of each assignment in specific terms;
- allow teachers within schools, school divisions/districts, and the province to collaborate in assessment; and
- play an important part in instruction.

## How Assessment Rubrics Enhance Instruction

The best assessment tools do not simply sort and score student work; instead, they describe it in specific terms. This assessment information:

- helps teachers adjust instruction to meet student learning requirements;
- tells students what teachers expect and will look for in their work, and helps them to focus their efforts;
- allows students to assess their own work using the criteria teachers will use to set goals and to monitor their progress; and
- aids in the development of metacognition by giving students a vocabulary for talking about particular aspects of their work.

## Sources of Assessment Rubrics

Teachers develop assessment rubrics in collaboration with students, on their own, and/or with other teachers—or obtain them through published sources.

- ***Classroom Development***

Developing assessment rubrics in collaboration with students can be a time-consuming process, but one that has many benefits in instruction and learning. (Both the benefits and the process are explored on the following pages.) Although it may not be possible to involve students in the process in every instance, some experience in developing rubrics will help students to use ready-made rubrics with more understanding.

- ***Teacher-Developed***

Teachers develop general performance and product rubrics individually, in collaboration within a school or school division/district. Rubrics must be adapted regularly to accurately reflect student performance levels.

It is important that teacher-developed rubrics use language that students understand, and that teachers provide an example of work at each level of proficiency. These examples (called anchors or exemplars) illustrate for students the descriptive phrases used in the rubrics.

- ***Published Sources***

High-quality assessment rubrics are available in various educational resources. The disadvantage of ready-made rubrics is that they may not be congruent with the learning outcomes targeted in a particular assignment, and may not accurately describe Senior 3 performance levels and criteria.

## Developing Rubrics in Collaboration with Students

### Student Benefits

Developing rubrics in collaboration with students requires students to look at work samples, and to identify the attributes that make some samples successful and others unsuccessful. Teachers assist students by providing them with the vocabulary to articulate the various elements they see, and by ensuring the criteria are comprehensive and consistent with learning outcomes. This process:

- requires students to make judgements about the work they see, and identify the qualities of effective writing, speaking, and representing of science concepts; and
- results in an assessment tool that students understand and feel they own—assessment criteria are not perceived as arbitrary or imposed, but rather express students' own observations about what constitutes quality work.

### The Development Process

For their first experience in designing a rubric, ask students to articulate the criteria they use in making judgements about something in everyday life—the quality of a restaurant, for example. The model rubric that they develop for assessing restaurants may help students grasp how the parts of a rubric work.

Students may also find it helpful to develop rubrics after they have done some preliminary work on the assessment task, and so are familiar with the demands of the particular assignment.

The process of developing assessment rubrics in collaboration with students involves numerous steps:

#### **1. Look at samples.**

Develop assessment rubrics by analyzing genuine samples of student work that illustrate the learning outcomes that the assessment task in question addresses. Samples are usually drawn from student work from previous years, used with permission and with names removed. Beginning teachers who do not have files of samples may need to borrow from colleagues.

Select samples that are clear and characteristic of student work at various levels. Streamline the process by distributing examples at only three levels of proficiency: excellent, adequate, and inadequate. Provide two or three examples of each level. Allow students time to read the examples and to talk about them in groups.



## **2. Describe the samples.**

Suggest that students focus on the examples of excellent work first. Pose the question: "What makes this piece successful?" Then ask students to brainstorm attributes of, or criteria for, success. Some of the attributes students list will describe behaviours that are useful in meeting the goals of the work (for example, the topic is stated at the beginning, there are few spelling errors, a graph is used to represent statistical findings).

What rubrics must attempt to articulate, beyond identifying these behaviours, is the essence of a good product or performance. As Wiggins (1995) points out, eye contact may be important in the performance of an oral report, but it is possible to deliver a dreary talk while maintaining eye contact (V1-5: 6). Together with students, identify the salient qualities of works related to science that are engaging and effective. These may be qualities that are harder to define and illustrate (for example, the speaker has moved beyond a superficial understanding of the subject, the producer of a video is aware of the audience, the writer's voice is discernible in a science journalism piece).

## **3. Develop criteria categories.**

From the brainstormed list of attributes, select the criteria categories that will make up the assessment rubric. Most rubrics are limited to three to five criteria categories. A greater number makes the rubrics difficult for assessors to use, especially in assessing live performances. Listing too many criteria can also overwhelm or confuse students who use the rubrics for self-assessment and setting goals.

Develop criteria categories by combining related attributes, and selecting three to five that are considered most important. Label the criteria categories in general terms (organization, style, content) and expand them by listing the specific elements to be examined in assessing quality in these criteria (for example, in the "organization" category, the elements may be "statement of purpose, topic sentences, transition words and phrases, paragraph breaks, order of ideas").

Ensure that no essential attribute that defines good performance is left out. This means including elements considered hard to assess (such as style or creativity). Ignoring elements such as these signals that they are not important. Addressing them helps students grasp the things they can do to improve their own work in these areas. If graphical analysis is identified as one criteria category, for example, the rubric may list elements that convey the details of such an analysis (for example, placement of dependent and independent variables, placement of data points, line of "best fit"). It may also provide definitions.

As students collaborate to develop criteria categories, monitor whether the criteria chosen are related to the intended learning outcomes.

**4. Decide how many performance levels the rubric will contain.**

The first rubric students develop will have three performance levels, based on identifying student work samples as excellent, adequate, or inadequate. In later rubrics, students may move to finer distinctions between levels. The number of levels needed to make meaningful judgements regarding the full range of proficiency is best decided by the teacher. If the scale is large (seven levels, for example), finer distinctions can be made, but it may be difficult to differentiate clearly one level from the next. In science, assessment rubrics designed to be used by students as well as teachers generally use three, four, or five performance levels.\*

Using the same number of performance levels for various tasks throughout the course has the advantage of giving students and the teacher a common vocabulary in talking about ways to improve performance (for example, "This piece does not have the concrete detail of level 4 writing"). Once the number of criteria categories and performance levels has been determined, a rubric template such as the following can be used in developing rubrics.

		Criteria Categories			
Performance Levels	1				
	2				
	3				
	4				
	5				

---

\* Many designers of rubrics advocate a five-level scale. Levels 1, 3, and 5 are developed from an initial sorting of student work into excellent, adequate, and inadequate samples. Levels 2 and 4 describe work that is between these anchor points. Other educators argue that an even-point scale (four or six levels) forces more care in judging than an odd number does; it prevents assessors from overusing a middle category for work that is difficult to assess.

**5. Describe the performance levels.**

In developing the assessment criteria (Step 3), students analyzed successful pieces of work. They now fill in descriptions of excellent, adequate, and inadequate performance in each criteria category.

There are two ways of describing performance levels:

- Evaluative rubrics use comparative adjectives (for example, “weak organization”).
- Descriptive rubrics specify the qualities of work at each performance level with respect to the criteria (for example, “unconnected ideas appear in the same paragraph”). The attributes listed may be negative (for example, “subscripts and coefficients are incorrectly applied”), for sometimes the most telling characteristic of certain levels is their failure to do what they should be doing.

Descriptive rubrics have many advantages over evaluative rubrics. They are more helpful to students, because they spell out the behaviours and qualities students encounter in assessing their own and others’ work, and the things they can address in their own work in order to improve.

When beginning to write descriptive rubrics, students may suggest generally descriptive adjectives (such as “interesting,” “boring”), which may not convey information about what an interesting piece looks like, and how they can improve their work in this area. The description needs to state the attributes that make a work interesting, and be in an acceptable style for scientific communication. Classes may need to begin by using comparative language or general descriptions. As the students and teacher collect examples, they can then fine-tune the rubric with specific descriptions.

By the end of this step, students will have a description of performance at three levels. If the class has decided to create a rubric with four, five, or six performance levels, it may be most efficient for the teacher to draft gradations of quality for the middle levels, and present them to the class for revision. These middle levels are the most difficult to write, and call on more experience and expertise in developing a smooth continuum of proficiency.

**6. Use the rubric for student self-assessment, for teacher assessment, and for instruction.**

Before using the rubric on an actual assignment, students and teachers may want to test it against unsorted samples of work from previous years. Applying the rubric to student work helps the class determine whether the rubric accurately describes the qualities of the work they see, and helps students make meaningful distinctions between work at different levels of proficiency. As students become more adept at using the rubric, and when they have internalized the performance levels, present them with more diverse samples and assessment challenges.

Rubrics make it possible for students to assess their own work on the basis of the criteria that the teacher will use. Any differences in scores between a student's and a teacher's assessment can be the subject of profitable and focussed discussion in student conferences.

If numerical scores are required, point values assigned to each level can be totalled. If the teacher and students decide that certain criteria categories should be more heavily weighted than others, the points assigned to these categories can be multiplied by a factor.

A rubric developed collaboratively can also become a valuable instructional tool, encouraging students to look closely at the specific things they can do to improve a piece of work. If students decide that a writing sample in science is at level 3, they can be asked to work together in groups to improve it so that it fits the description for level 4 work.

***7. Continue to revise the rubric.***

Any assessment rubric can be considered a work in progress, especially if it is stored on the computer. Both teacher and students should carefully review the rubric each time they use it, asking, "Do these criteria capture the most important qualities of excellence in this work?" "What other words and phrases can we use to describe work at this level?" In keeping with this, the rubrics appearing in the Appendix of this document are intended as templates, open to situational revisions.

# APPENDIX 6: ASSESSMENT RUBRICS

## Rubric for the Assessment of Class Presentations

Student Name(s) \_\_\_\_\_

Topic/Title \_\_\_\_\_

Criteria	Performance Levels			
	Level 1	Level 2	Level 3	Level 4
Content	<ul style="list-style-type: none"> <li><input type="checkbox"/> No understanding of the topic was evident.</li> <li><input type="checkbox"/> Basic understanding of the topic was evident.</li> <li><input type="checkbox"/> Student(s) did not relate the material presented to their own experiences.</li> </ul>	<ul style="list-style-type: none"> <li><input type="checkbox"/> Good understanding of the topic.</li> <li><input type="checkbox"/> Knowledge is thorough and detailed.</li> <li><input type="checkbox"/> Student(s) attempted to relate the material presented to their own experiences.</li> </ul>	<ul style="list-style-type: none"> <li><input type="checkbox"/> Excellent depth of understanding is evident.</li> <li><input type="checkbox"/> Student(s) presented material that was further than what was required. Excellent research.</li> <li><input type="checkbox"/> Student(s) showed how the material presented relates to their own experiences.</li> </ul>	<ul style="list-style-type: none"> <li><input type="checkbox"/> The interest of the presenter(s) was exceptional as was their enthusiasm.</li> <li><input type="checkbox"/> The class was keenly attentive during the presentation.</li> </ul>
Interest and Enthusiasm	<ul style="list-style-type: none"> <li><input type="checkbox"/> Little interest and enthusiasm for the topic was displayed in the presentation.</li> </ul>	<ul style="list-style-type: none"> <li><input type="checkbox"/> Some interest and enthusiasm was evident in the presentation.</li> <li><input type="checkbox"/> The class was not very interested or enthusiastic.</li> </ul>	<ul style="list-style-type: none"> <li><input type="checkbox"/> The presenters were clearly interested in their topic and their enthusiasm was quite evident.</li> <li><input type="checkbox"/> The class was noticeably attentive during the presentation.</li> </ul>	<ul style="list-style-type: none"> <li><input type="checkbox"/> All information was relevant and clearly presented.</li> <li><input type="checkbox"/> The presentation was extremely well organized.</li> <li><input type="checkbox"/> Main points were emphasized and reinforced with appropriate examples.</li> </ul>
Clarity and Organization of Material	<ul style="list-style-type: none"> <li><input type="checkbox"/> The information presented was confusing.</li> </ul>	<ul style="list-style-type: none"> <li><input type="checkbox"/> The information was somewhat vague.</li> <li><input type="checkbox"/> There was some organization.</li> </ul>	<ul style="list-style-type: none"> <li><input type="checkbox"/> The information was clearly presented.</li> <li><input type="checkbox"/> The presentation was well organized.</li> </ul>	<ul style="list-style-type: none"> <li><input type="checkbox"/> Strong visual aids were used.</li> <li><input type="checkbox"/> Visual aids were extremely well done with colour, clarity, and care.</li> <li><input type="checkbox"/> Visual aids were designed to emphasize and strengthen the presentation and were successful.</li> </ul>
Use of Visual Aids	<ul style="list-style-type: none"> <li><input type="checkbox"/> Visual aids were not used.</li> </ul>	<ul style="list-style-type: none"> <li><input type="checkbox"/> Visual aids were used.</li> <li><input type="checkbox"/> Visual aids were not well done.</li> <li><input type="checkbox"/> Visual aids used were somewhat relevant to the presentation.</li> </ul>	<ul style="list-style-type: none"> <li><input type="checkbox"/> Visual aids were used.</li> <li><input type="checkbox"/> Visual aids were quite well done.</li> <li><input type="checkbox"/> Visual aids were relevant to the presentation.</li> </ul>	<ul style="list-style-type: none"> <li><input type="checkbox"/> Visual aids were used.</li> <li><input type="checkbox"/> Visual aids were extremely well done with colour, clarity, and care.</li> <li><input type="checkbox"/> Visual aids were designed to emphasize and strengthen the presentation and were successful.</li> </ul>

*\*Teachers are reminded that this rubric would vary with the assignment and format of the presentation.*

## Rubric for the Assessment of a Research Project

Student Name(s) \_\_\_\_\_

Topic/Title \_\_\_\_\_

Criteria	Performance Levels			
	Level 1	Level 2	Level 3	Level 4
Source of Information	<input type="checkbox"/> Student(s) used only one source of information.	<input type="checkbox"/> Student(s) used two sources of information.	<input type="checkbox"/> Student(s) used a variety of sources.	<input type="checkbox"/> Student(s) used a wide variety of sources in a unique manner.
Information Collected	<input type="checkbox"/> The information collected was not relevant.	<input type="checkbox"/> The information collected was relevant to the topic but was not blended into a cohesive piece.	<input type="checkbox"/> The information collected was relevant to the topic and was somewhat organized into a cohesive piece.	<input type="checkbox"/> The information collected was relevant to the topic and was carefully organized into a cohesive piece of research.
Organization of Material	<input type="checkbox"/> The information collected was not organized.	<input type="checkbox"/> The information was somewhat organized.	<input type="checkbox"/> The information was organized and contained recognizable sections.	<input type="checkbox"/> The information was organized and contained recognizable sections that included an introduction, a main body with supporting evidence, and a conclusion that summarized the report.
Presentation of Material	<input type="checkbox"/> The report was handwritten, contrary to established guidelines.	<input type="checkbox"/> The report was neatly handwritten. <input type="checkbox"/> The report contained a bibliography that was not correctly formatted.	<input type="checkbox"/> The report was typed. <input type="checkbox"/> The report contained graphics. <input type="checkbox"/> The report contained a bibliography that was not correctly formatted.	<input type="checkbox"/> The report was typed and appropriately formatted. <input type="checkbox"/> The report contained a title page. <input type="checkbox"/> The report contained relevant graphics. <input type="checkbox"/> The report contained a complete, correctly formatted bibliography.

*\*Teachers are reminded that this rubric would vary with the assignment and format of the presentation.*

## Rubric for the Assessment of a Decision-Making Process Activity

Student Name(s) \_\_\_\_\_

Topic/Title \_\_\_\_\_

Criteria	Performance Levels			
	Level 1	Level 2	Level 3	Level 4
Identification of STSE Issue	<ul style="list-style-type: none"> <li><input type="checkbox"/> Student(s) cannot identify an STSE issue without assistance.</li> </ul>	<ul style="list-style-type: none"> <li><input type="checkbox"/> Student(s) have a basic understanding that an issue could have STSE implications, not necessarily differentiating among the four areas.</li> </ul>	<ul style="list-style-type: none"> <li><input type="checkbox"/> Student(s) have a good understanding of a connection between an issue and its STSE applications.</li> <li><input type="checkbox"/> Some evidence of awareness of an individual response.</li> </ul>	<ul style="list-style-type: none"> <li><input type="checkbox"/> Student(s) have excellent depth and sensitivity in connecting an issue with its STSE implications.</li> <li><input type="checkbox"/> A level of social responsibility is demonstrated.</li> </ul>
Evaluates Current Research on Issue	<ul style="list-style-type: none"> <li><input type="checkbox"/> Student(s) able to access a small amount of current research, with no evaluation of that research evident.</li> </ul>	<ul style="list-style-type: none"> <li><input type="checkbox"/> Student(s) demonstrate some ability to recognize the positions taken in the research data, with no clear evaluative statements.</li> </ul>	<ul style="list-style-type: none"> <li><input type="checkbox"/> Student(s) have secured an array of research, narrow in its scope, but clearly identify the positions taken.</li> <li><input type="checkbox"/> Can offer personal opinions on issue, not necessarily evaluation.</li> </ul>	<ul style="list-style-type: none"> <li><input type="checkbox"/> All acquired research of student(s) is current, relevant, and from a variety of perspectives.</li> <li><input type="checkbox"/> Demonstrates insight into the stated positions, and can frame an evaluation.</li> </ul>
Formulates Possible Options	<ul style="list-style-type: none"> <li><input type="checkbox"/> Student(s) unable to clearly identify the possible options.</li> <li><input type="checkbox"/> Can form options that are not clearly connected to the problem to be solved.</li> </ul>	<ul style="list-style-type: none"> <li><input type="checkbox"/> Student(s) can offer at least one feasible option that is connected to the problem.</li> <li><input type="checkbox"/> Other options may be more or less related directly to the problem.</li> </ul>	<ul style="list-style-type: none"> <li><input type="checkbox"/> Student(s) develop at least two feasible options that are internally consistent, and directly address the problem.</li> <li><input type="checkbox"/> Recognize that some options will fail.</li> </ul>	<ul style="list-style-type: none"> <li><input type="checkbox"/> Student(s) display level of sophistication of feasible options that is beyond expectations.</li> <li><input type="checkbox"/> All options demonstrate a reasonable chance of succeeding at being chosen.</li> </ul>
Identifies Projected Impacts	<ul style="list-style-type: none"> <li><input type="checkbox"/> Student(s) not able to foresee the possible consequences of the options selected.</li> <li><input type="checkbox"/> There appears to be a naive awareness of consequences.</li> </ul>	<ul style="list-style-type: none"> <li><input type="checkbox"/> Student(s) identify potential impacts of decisions taken in a vague or insubstantial way.</li> <li><input type="checkbox"/> Most of the feasible options are viewed as having projected impacts.</li> </ul>	<ul style="list-style-type: none"> <li><input type="checkbox"/> Student(s) identify potential impacts of decisions taken in an organized way.</li> <li><input type="checkbox"/> All of the feasible options are viewed as having projected impacts: some beneficial, some not.</li> </ul>	<ul style="list-style-type: none"> <li><input type="checkbox"/> Student(s) are capable of offering a cost/benefits/risks analysis of each feasible solution.</li> <li><input type="checkbox"/> Construct an organized report that clearly outlines the impacts of each.</li> </ul>

## Rubric for the Assessment of a Decision-Making Process Activity (continued)

Student Name(s) \_\_\_\_\_

Topic/Title \_\_\_\_\_

Criteria	Performance Levels			
	Level 1	Level 2	Level 3	Level 4
Selects an Option and Makes a Decision	<ul style="list-style-type: none"> <li><input type="checkbox"/> Unable to come to a decision that clearly connects with the problem to be solved.</li> <li><input type="checkbox"/> Requires direction from the outside to make a choice.</li> </ul>	<ul style="list-style-type: none"> <li><input type="checkbox"/> Can identify a feasible option, but is faced with the inability to clearly decide on a plan.</li> <li><input type="checkbox"/> Still requiring outside influences to stand by a decision to proceed.</li> </ul>	<ul style="list-style-type: none"> <li><input type="checkbox"/> Clearly selects an option, but others can identify that a better course of action remains untried.</li> <li><input type="checkbox"/> Recognizes potential safety concerns.</li> </ul>	<ul style="list-style-type: none"> <li><input type="checkbox"/> A thorough analysis of all options was done collaboratively.</li> <li><input type="checkbox"/> Decision was firm, justified by the research base, and recognizes most of the safety concerns.</li> </ul>
Implements the Decision	<ul style="list-style-type: none"> <li><input type="checkbox"/> Unable to fully implement the decision, but there remains opportunity to modify it.</li> <li><input type="checkbox"/> Decision lacks the clarity to proceed.</li> </ul>	<ul style="list-style-type: none"> <li><input type="checkbox"/> Implements the decision with a recognition that not all details are laid out in advance.</li> <li><input type="checkbox"/> Some lack of clarity in having a plan for implementation.</li> </ul>	<ul style="list-style-type: none"> <li><input type="checkbox"/> Implements with some visible clarity of purpose.</li> <li><input type="checkbox"/> Confidence is demonstrated that the plan will be one that can be of a scientific inquiry approach.</li> </ul>	<ul style="list-style-type: none"> <li><input type="checkbox"/> Implements a plan with visible clarity of purpose, backed by the research base.</li> <li><input type="checkbox"/> It is clearly demonstrated that the plan will be one that can be carried to completion as inquiry.</li> </ul>
Identifies and Evaluates Actual Impacts of Decision	<ul style="list-style-type: none"> <li><input type="checkbox"/> Unable to clearly recognize more than one possible actual impact.</li> <li><input type="checkbox"/> Cannot effectively evaluate the effects of the decision(s) taken.</li> </ul>	<ul style="list-style-type: none"> <li><input type="checkbox"/> Can clearly recognize more than one possible actual impact for the decision taken.</li> <li><input type="checkbox"/> Cannot effectively evaluate the effects of the decision(s) taken in most instances.</li> </ul>	<ul style="list-style-type: none"> <li><input type="checkbox"/> Able to recognize and comment upon the actual impacts observed.</li> <li><input type="checkbox"/> Some ability in evaluating the impacts of the decision.</li> </ul>	<ul style="list-style-type: none"> <li><input type="checkbox"/> Able to recognize and comment deeply upon the actual impacts observed, noting unforeseen or unique outcomes.</li> <li><input type="checkbox"/> Facility in evaluating the impacts of the decision.</li> </ul>
Reflects on the Decision Making and Implementation of a Plan	<ul style="list-style-type: none"> <li><input type="checkbox"/> Begins to demonstrate an awareness of the need to review the plan.</li> <li><input type="checkbox"/> A reluctance to consider a re-evaluation of the plan.</li> </ul>	<ul style="list-style-type: none"> <li><input type="checkbox"/> Reflects and intends to communicate the results of the implementation plan.</li> <li><input type="checkbox"/> Has some difficulty in how to proceed with a re-evaluation of the problem-solving plan.</li> </ul>	<ul style="list-style-type: none"> <li><input type="checkbox"/> Reflects upon and does communicate the results of the implementation plan.</li> <li><input type="checkbox"/> Recognizes how to proceed with a re-evaluation of the problem-solving plan.</li> </ul>	<ul style="list-style-type: none"> <li><input type="checkbox"/> A higher order synthesis was visible in the reflection process.</li> <li><input type="checkbox"/> Evidence of a sophisticated environmental awareness that informs this post-implementation period.</li> </ul>

*\* Teachers are reminded that the above criteria are suggestions only, and will be adapted according to the needs of the assignment. It is preferable if this rubric is modified in consultation with the students, leading to clarity of purpose.*



## Lab Report Assessment

Project Title \_\_\_\_\_ Date \_\_\_\_\_

Team Members \_\_\_\_\_

Area of Interest	Possible Points	Self	Teacher
<p><b>Formulates Testable Questions:</b> Question is testable and focussed with cause-and-effect relationship identified.</p>			
<p><b>Formulates a Prediction/Hypothesis:</b> Independent and dependent variables are identified and the prediction/hypothesis clearly identifies a cause-and-effect relationship between these two variables.</p>			
<p><b>Creates a Plan:</b> All steps are included and clearly described in a logical sequence. All required materials/equipment are identified. Safety considerations are addressed; major intervening variables are controlled.</p>			
<p><b>Conducts a Fair Test and Records Observations:</b> There is evidence of repeated trials and the inclusion of all data. Detailed data are recorded, and appropriate units are used; data are recorded in a clear/well-structured/appropriate format for later reference.</p>			
<p><b>Interprets and Evaluates Results:</b> Patterns/trends/discrepancies are identified. Strengths and weaknesses of approach and potential sources of error are identified. Changes to the original plan are identified and justified.</p>			
<p><b>Draws a Conclusion:</b> Conclusion explains cause-and-effect relationship between dependent and independent variables; alternative explanations are identified; hypothesis is supported or rejected.</p>			
<p><b>Makes Connections:</b> Potential applications are identified and/or links to area of study are made.</p>			
<p><b>Total Points</b></p>			



## Rubric for Student Presentation

Student Name(s) \_\_\_\_\_

Topic/Title \_\_\_\_\_

Criteria	Performance Levels			
	Level 1	Level 2	Level 3	Level 4
Organization	<input type="checkbox"/> Presentation shows poor organization and lack of preparation.	<input type="checkbox"/> Presentation shows signs of organization but some parts do not seem to fit the topic.	<input type="checkbox"/> Presentation is organized, logical, and interesting.	<input type="checkbox"/> Presentation is very well organized, logical, interesting, and lively.
Preparation	<input type="checkbox"/> Some student preparation is shown.	<input type="checkbox"/> A fair amount of student preparation is shown.	<input type="checkbox"/> An adequate amount of student preparation is shown.	<input type="checkbox"/> A great deal of student preparation is shown.
Content	<input type="checkbox"/> Small amount of material presented is related to the topic.	<input type="checkbox"/> Some material presented is not related to the topic.	<input type="checkbox"/> Almost all material presented is related to the topic.	<input type="checkbox"/> All material in the presentation is related to the topic.
Language	<input type="checkbox"/> Language used is hard to follow and understand.	<input type="checkbox"/> Some language used is hard to follow and understand.	<input type="checkbox"/> Most language used is easy to follow and understand.	<input type="checkbox"/> Language used is well chosen, easy to follow and understand.
Format	<input type="checkbox"/> Poor use of aids and support materials (diagrams, overheads, maps, pictures); does not support the topic.	<input type="checkbox"/> Adequate use of aids and support materials; most support the topic.	<input type="checkbox"/> Good use of aids and support materials; almost all support the topic.	<input type="checkbox"/> Excellent use of aids and support materials; all aids support the topic.
Delivery	<input type="checkbox"/> Many words are unclear; voice is monotonous; spoke too quickly or slowly; no pausing for emphasis; voice is too low to be heard easily.	<input type="checkbox"/> Some words are unclear; voice is somewhat varied; spoken too quickly at times; some pausing for emphasis; voice is sometimes too low to be heard easily.	<input type="checkbox"/> Most words are clear; voice is often varied, interesting, correct speed; frequent pausing for emphasis; voice is loud enough to be heard easily.	<input type="checkbox"/> Words are clear; voice is frequently varied, interesting, generally spoken at the correct speed; effective pausing for emphasis; voice is loud enough to be heard easily.
Audience	<input type="checkbox"/> Audience is not involved or interested.	<input type="checkbox"/> Audience is somewhat involved, sometimes interested.	<input type="checkbox"/> Audience is involved and interested.	<input type="checkbox"/> Audience is very involved and interested.

\* Teachers are reminded that the above criteria are suggestions only, and will be adapted according to the needs of the assignment. It is preferable if this rubric is modified in consultation with the students, leading to clarity of purpose.

## Rubric for Research Skills

Student Name(s) \_\_\_\_\_

Topic/Title \_\_\_\_\_

Research Skills	Performance Levels			
	Level 1	Level 2	Level 3	Level 4
Ability to formulate questions to identify problems for research purposes	<input type="checkbox"/> Shows limited ability	<input type="checkbox"/> Shows some ability	<input type="checkbox"/> Shows general ability	<input type="checkbox"/> Shows consistent and thorough ability
Ability to locate relevant primary and secondary sources of information	<input type="checkbox"/> Unable to locate	<input type="checkbox"/> Somewhat able to locate	<input type="checkbox"/> Generally able to locate	<input type="checkbox"/> Always or almost always able to locate
Ability to locate and record relevant information from a variety of sources	<input type="checkbox"/> Unable to locate and record	<input type="checkbox"/> Somewhat able to locate	<input type="checkbox"/> Generally able to locate and record	<input type="checkbox"/> Always or almost always able to locate and record
Ability to organize information related to identified problem(s)	<input type="checkbox"/> Shows limited ability	<input type="checkbox"/> Shows some ability	<input type="checkbox"/> Shows general ability	<input type="checkbox"/> Shows consistent and thorough ability
Ability to analyze, synthesize information related to identified problems	<input type="checkbox"/> Shows limited ability	<input type="checkbox"/> Shows some ability	<input type="checkbox"/> Shows general ability	<input type="checkbox"/> Shows consistent and thorough ability
Ability to communicate results of inquiries using a variety of appropriate presentation forms (oral, media, written, graphic, pictorial, other)	<input type="checkbox"/> Unable to communicate	<input type="checkbox"/> Somewhat able to communicate	<input type="checkbox"/> Generally able to communicate	<input type="checkbox"/> Always or almost always able to communicate

*\*Teachers are reminded that this rubric would vary with the assignment and format of the presentation.*

---

## **APPENDIX 7: GENERAL LEARNING OUTCOMES**

### **Nature of Science and Technology**

- A1. recognize both the power and limitations of science as a way of answering questions about the world and explaining natural phenomena
- A2. recognize that scientific knowledge is based on evidence, models, and explanations, and evolves as new evidence appears and new conceptualizations develop
- A3. distinguish critically between science and technology in terms of their respective contexts, goals, methods, products, and values
- A4. identify and appreciate contributions made by women and men from many societies and cultural backgrounds towards increasing our understanding of the world and in bringing about technological innovations
- A5. recognize that science and technology interact with and advance one another

### **Science, Technology, Society, and the Environment (STSE)**

- B1. describe scientific and technological developments, past and present, and appreciate their impact on individuals, societies, and the environment, both locally and globally
- B2. recognize that scientific and technological endeavours have been and continue to be influenced by human needs and the societal context of the time
- B3. identify the factors that affect health and explain the relationships among personal habits, lifestyle choices, and human health, both individual and social
- B4. demonstrate a knowledge of, and personal consideration for, a range of possible science- and technology-related interests, hobbies, and careers
- B5. identify and demonstrate actions that promote a sustainable environment, society, and economy, both locally and globally

### **Scientific and Technological Skills and Attitudes**

- C1. recognize safety symbols and practices related to scientific and technological activities and to their daily lives, and apply this knowledge in appropriate situations
- C2. demonstrate appropriate scientific inquiry skills when seeking answers to questions
- C3. demonstrate appropriate problem-solving skills while seeking solutions to technological challenges
- C4. demonstrate appropriate critical thinking and decision-making skills when choosing a course of action based on scientific and technological information

- C5. demonstrate curiosity, skepticism, creativity, open-mindedness, accuracy, precision, honesty, and persistence, and appreciate their importance as scientific and technological habits of mind
- C6. employ effective communication skills and utilize information technology to gather and share scientific and technological ideas and data
- C7. work cooperatively and value the ideas and contributions of others while carrying out scientific and technological activities
- C8. evaluate, from a scientific perspective, information and ideas encountered during investigations and in daily life

### **Essential Science Knowledge**

- D1. understand essential life structures and processes pertaining to a wide variety of organisms, including humans
- D2. understand various biotic and abiotic components of ecosystems, as well as their interaction and interdependence within ecosystems and within the biosphere as a whole
- D3. understand the properties and structures of matter as well as various common manifestations and applications of the actions and interactions of matter
- D4. understand how stability, motion, forces, and energy transfers and transformations play a role in a wide range of natural and constructed contexts
- D5. understand the composition of the Earth's atmosphere, hydrosphere, and lithosphere, as well as the processes involved within and among them
- D6. understand the composition of the universe, the interactions within it, and the impacts of humankind's continued attempts to understand and explore it

### **Unifying Concepts**

- E1. describe and appreciate the similarity and diversity of forms, functions, and patterns within the natural and constructed world
- E2. describe and appreciate how the natural and constructed world is made up of systems and how interactions take place within and among these systems
- E3. recognize that characteristics of materials and systems can remain constant or change over time, and describe the conditions and processes involved
- E4. recognize that energy, whether transmitted or transformed, is the driving force of both movement and change, and is inherent within materials and in the interactions among them

---

## ***BIBLIOGRAPHY***

---

## BIBLIOGRAPHY

- Alberta Education. *Workshop Materials. Alberta Education*. Edmonton, AB: 1989.
- Arons, Arnold B. *A Guide to Introductory Physics Teaching*. New York, NY: Wiley, 1990.
- Bonham, S. "Using Physlets to Teach Electrostatics." *The Physics Teacher* 37.5 (May 1999): 276.
- Bransford, John D., Ann L. Brown, and Rodney R. Cocking, eds. *How People Learn: Brain, Mind, Experience, and School: Expanded Edition: A National Research Council Report*. Washington, DC: National Academy Press, 2000.
- Brush, Steven. "Whole Earth History." *Historical Studies in the Physical Sciences* 17.2 (1997): 345-355. Available online at: <http://punsterproductions.com/~sciencehistory/WEH.htm>
- Bybee, Rodger W., C. Edward Buchwald, Sally Crissman, David R. Heil, Paul J. Kuerbis, Carolee Matsumoto, and Joseph P. McInerney. In *Science and Technology Education for the Elementary Years: Frameworks for Curriculum and Instruction*. Rowley, MA: The NETWORK Inc., 1989.
- Champagne, A.B., R.F. Gunstone, and L.E. Klopfer. "Instructional Consequences of Students' Knowledge about Physical Phenomena." *Cognitive Structure and Conceptual Change*. ed. L.H.T. West and A.L. Pines. New York, NY: Academic Press, 1985.
- Clement, John. "A Conceptual Model Discussed by Galileo and Used Intuitively by Physics Students." In *Mental Models*. Ed. Dedre Gentner and Albert L. Stevens. London, UK: Lawrence Erlbaum Associates, 1983.
- Corno, Lyn, and Judi Randi. "Motivation, Volition, and Collaborative Innovation in Classroom Literacy." In *Reading Engagement: Motivating Readers through Integrated Sources*. Ed. John T. Guthrie, and Allan Wigfield. Newark, DE: International Reading Association, 1997.
- Council of Ministers of Education, Canada. *Common Framework of Science Learning Outcomes K to 12: Pan-Canadian Protocol for Collaboration on School Curriculum*. Toronto, ON: Council of Ministers of Education, Canada, 1997.
- Court, J. "Free Body Diagrams." *The Physics Teacher* 31.2 (1993): 104.
- Court, J. "Free Body Diagrams." *The Physics Teacher* 37.7 (1999): 427.
- Drake, Susan M. *Planning Integrated Curriculum: The Call to Adventure*. Alexandria VI: Association for Supervision and Curriculum Development, 1993.



- Ellis, Edwin S., Donald D. Deshler, B. Keith Lenz, Jean B. Shumaker, and Francis L. Clark. "An Instructional Model for Teaching Learning Strategies." *Focus on Exceptional Children* 23.6 (Feb. 1991): 1-22.
- Evans, L., and J. Stevens. "Which Way Is Up?" *The Physics Teacher* 16.8 (1978): 561.
- Fisher, K. "Exercise in Drawing and Utilizing Free-Body Diagrams." *The Physics Teacher* 37.7 (1999): 434.
- Foster, Graham. *Student Self-Assessment: A Powerful Process for Helping Students Revise Their Writing*. Markham, ON: Pembroke, 1996.
- Glatthorn, Allan A. *Learning Twice: An Introduction to the Methods of Teaching*. New York, NY: HarperCollins College, 1993.
- Good, Thomas L., and Jero E. Brophy. *Looking in Classrooms*. New York, NY: Harper and Row, 1987.
- Haber-Schaim, Uri, John H. Dodge, and James A. Walter. *PSSC Physics*. 8th ed. New York, NY: D.C. Heath and Company, 1991.
- Hake, R.R. "Interactive Engagement Versus Traditional Methods: A Six-Thousand-Student Survey of Mechanics Test Data for Introductory Physics Courses." *American Journal of Physics* 66.1 (1998): 64-74.
- Halloun, I. "Views about Science and Physics Achievement. The VASS Story." In *Proceedings of the International Conference on Undergraduate Physics Education*. Ed. E.F. Redish and J.S. Rigden. Washington, DC: American Institute of Physics, 1998.
- Hammer, D. "Epistemological Considerations in Teaching Introductory Physics." *Science Education* 79.4 (1995): 393-413.
- Hammer, D. "Discovery Learning and Discovery Teaching." *Cognition and Instruction* 15.4 (1997): 485-529.
- Herreman, W., and R. Huysentruyt. "Measuring the Magnetic Force on a Current Carrying Conductor." *The Physics Teacher* 33.5 (1995): 288.
- Hestenes, David, and Malcolm Wells. "A Mechanics Baseline Test." *The Physics Teacher* 30.3 (1992): 159-166.
- Hestenes, David, Malcolm Wells, and Gregg Swackhamer. "Force Concept Inventory." *The Physics Teacher* 30 (1992): 141-151.
- Hewson, P.W. "Epistemological commitments in the Learning of Science: Examples from Dynamics." *European Journal of Science Education* 7.2 (1985): 163-172.
- Hirsch, Alan. *Physics for a Modern World*. Toronto, ON: John Wiley & Sons, 1986.

- Hoy, R.R. "A 'Model Minority' Speaks Out on Cultural Shyness." *Science* 262 (1993): 1117-1118.
- Iona, M. "Weight—An Official Definition." *The Physics Teacher* 37.4 (1999): 238.
- Jensen, L. "Apparent Weight Changes in an Elevator." In *A Potpourri of Physics Teaching Ideas*. Ed. Donna Berry Conner. College Park, MD: American Association of Physics Teachers Publications Department, 1986.
- Kagan, D. "Building a Magnetic Levitation Toy." *The Physics Teacher* 31 (1993): 432.
- Kolodny, A. "Colleges Must Recognize Students' Cognitive Styles and Cultural Backgrounds." *Chronicle of Higher Education* 37.21 (1991): A44.
- Kuhn, Thomas. "Objectivity, Value Judgement, and Theory Choice." In *The Essential Tension: Selected Studies in Scientific Tradition and Change*. Chicago, IL: University of Chicago Press, 1977.
- Kuhn, Thomas S. *The Structure of Scientific Revolutions*. Chicago, IL: University of Chicago Press, 1962.
- Lapp, D. R. "Field Lines Flying Fur." *The Physics Teacher* 34.4 (1996): 252.
- Larochelle, Marie, et Jacques Désautels. *Autour de l'idée de science: itinéraires cognitifs d'étudiants et d'étudiantes*. Laval, QC: Presse de l'université Laval, 1992.
- Lederman, Norm G., Fouad Abd-El-Khalick, Randy L. Bell, and Renée S. Schwartz. "Views of nature of science questionnaire: Toward valid and meaningful assessment of learners' conceptions of the nature of science." *Journal of Research in Science Teaching* 39.6 (2002): 497-521.
- Locke, E.A., and G.P. Latham. *A Theory of Goal Setting and Task Performance*. Englewood Cliffs, NJ: Prentice Hall, 1990.
- Manitoba Education and Training. *A Foundation for Excellence*. Renewing Education: New Directions series. Winnipeg, MB: Manitoba Education and Training, 1995.
- . *Education for a Sustainable Future: A Resource for Curriculum Developers, Teachers, and Administrators*. Winnipeg, MB: Manitoba Education and Training, 2000.
- . *Reporting on Student Progress and Achievement: A Policy Handbook for Teachers, Administrators, and Parents*. Renewing Education: New Directions series. Winnipeg, MB: Manitoba Education and Training, 1997.
- . *Science Safety: A Kindergarten to Senior 4 Resource Manual for Teachers, Schools, and School Divisions*. Renewing Education: New Directions series. Winnipeg, MB: Manitoba Education and Training, 1997.

- . *Senior 2 English Language Arts: A Foundation for Implementation*. Renewing Education: New Directions series. Winnipeg, MB: Manitoba Education and Training, 1998.
- . *Senior 3 English Language Arts: A Foundation for Implementation*. Renewing Education: New Directions series. Winnipeg, MB: Manitoba Education and Training, 1999.
- . *Senior Years Science Teachers' Handbook*. Renewing Education: New Directions series. Winnipeg, MB: Manitoba Education and Training, 1997.
- . *Success for All Learners: A Handbook on Differentiating Instruction: A Resource for Kindergarten to Senior 4*. Renewing Education: New Directions series. Winnipeg, MB: Manitoba Education and Training, 1996.
- . *Technology As a Foundation Skill Area: A Journey Toward Information Technology Literacy: A Resource for Curriculum Developers, Teachers, and Administrators*. Renewing Education: New Directions series. Winnipeg, MB: Manitoba Education and Training, 1998.
- Maxwell, Rhoda J., and Mary J. Meiser. *Teaching English in Middle and Secondary Schools*. 2nd ed. Upper Saddle River, NJ: Prentice Hall, 1997.
- McComas, W.F. "Ten myths of science: Reexamining what we think we know about the nature of science." *School Science and Mathematics* 96 (1996): 10-16.
- McDermott, L.C. "What We Teach and What Is Learned—Closing the Gap." *American Journal of Physics* 59.4 (1991): 301-315.
- McDermott, L.C., and E.F. Redish. "Resource Letter PER-1: Physics Education Research." *American Journal of Physics* 67 (1999): 755-767.
- McDermott, L., and P. Schaffer. "Research as a guide for curriculum development: Part I: An example from introductory electricity." *American Journal of Physics* 60.11 (1992): 994-1003.
- Millar, Robin, and Jonathan Osborne, eds. *Beyond 2000, Science Education for the Future*. London, UK: King's College, 1998. Available online at <http://www.kcl.ac.uk/depsta/education/be2000/be2000.pdf>.
- Minstrell, J. "Teaching Science for Understanding." In *Toward the Thinking Curriculum: Current Cognitive Research*. Ed. L.B. Resnick and I.E. Klopfer. Alexandria, VA: American Society for Curriculum Development, 1989. 129-149.
- Murray, John James. "Historical and Philosophical Perspectives on Teaching the New Global Tectonics." M.Sc.Ed. thesis. Winnipeg, MB: The University of Manitoba, 2002.
- National Academy of Sciences. *Changing Emphases in Assessment of Student Learning*. Washington, DC: National Academy Press, 1996.

- National Research Council. *National Science Education Standards*. Washington, DC: National Academy Press, 1996.
- . *Science Teaching Reconsidered*. Washington, DC: Committee on Undergraduate Science Education. Division on Behavioral and Social Sciences and Education. National Academy Press, 1997.
- Nelson, J. "Kinematics of a Student." *The Physics Teacher* 21.6 (1983): 386.
- Probst, Robert E. *Response and Analysis: Teaching Literature in Junior and Senior High School*. Don Mills, ON: Heinemann, 1988.
- Purcell-Gates, Victoria. "Process Teaching With Direct Instruction and Feedback in a University-Based Clinic." In *Balanced Instruction: Strategies and Skills in Whole Language*. Ed. Ellen McIntyre and Michael Pressley. Norwood, MA: Christopher-Gordon, 1996.
- Redish, E.F., R.N. Steinberg, and J.M. Saul. "The Distribution and Change of Student Expectations in Introductory Physics." In *Proceedings of the International Conference on Undergraduate Physics Education (1996)*. Ed. E.F. Redish and J.S. Rigden. Washington, DC: American Institute of Physics, 1998.
- Reif, F., and J.H. Larkin. "Cognition in Scientific and Everyday Domains: Comparison and Learning Implications." *Journal of Research in Science Teaching* 28 (1991): 733-760.
- Rossing, Thomas. *The Science of Sound*. 2nd ed. New York, NY: Addison Wesley, 1990.
- Roth, W.M., and K.B. Lucas. "From 'Truth' to 'Invented Reality': A Discourse Analysis of High School Physics Students' Talk About Scientific Knowledge." *Journal of Research in Science Teaching* 34.2 (1997): 145-179.
- Ryan, Richard M., James P. Connell, and Edward L. Deci. "A Motivational Analysis of Self-Determination and Self-Regulation in Education." In *Research and Motivation in Education: The Classroom Milieu*. Vol. 2. Ed. Russell Ames and Carole Ames. New York, NY: Academia Press, 1985.
- Saskatchewan Education. *Instructional Approaches: A Framework for Professional Practice*. Regina, SK: Saskatchewan Education, 1991.
- Schunk, Dale H., and Barry Zimmerman. "Developing Self-Efficacious Readers and Writers: The Role of the Social and Self-Regulatory Processes." In *Reading Engagement: Motivating Readers through Integrated Sources*. Ed. John T. Guthrie and Allan Wigfield. Newark, DE: International Reading Association, 1997.
- Silver, E.A., and S.P. Marshall. "Mathematical and Scientific Problem Solving: Findings, Issues, and Educational Implications." In *Dimensions of Thinking and Cognitive Instruction*. Ed. B.J. Jones and L. Idol. Hillsdale, NJ: Lawrence, 1990.

- Spivey, J., "A Versatile Mount for Slinky Wave Demonstrator." In *AAPT Potpourri of Physics Teaching Ideas*. Ed. Donna Berry Conner. College Park, MD: American Association of Physics Teachers Publications Department, 1986.
- Stinner, A. "Contextual Settings, Science Stories, and Large Context Problems: Toward a More Humanistic Science Education." *Science Education* 79.5 (1995): 555-581.
- . "Providing a contextual base and a theoretical structure to guide the teaching of high school physics." *Physics Education* 29 (1994a): 75.
- . "Science Textbooks and Science Teaching: From Logic to Evidence." *Science Education* 76.1 (1992): 1-16.
- . "The story of force: from Aristotle to Einstein." *Physics Education* 29 (1994b): 77-85.
- Stinner, A., and H. Williams. "Conceptual Change, History, and Science Stories." *Interchange* 24.1 (1993): 87-103.
- Strickland, Dorothy S., and Michael R. Strickland. "Language and Literacy: The Poetry Connection." *Language Arts* 74 (March 1997): 201-205.
- Sustainability Manitoba. *Sustainable Development Strategy for Manitoba*. Winnipeg, MB: Sustainability Manitoba, 1998.
- Turner, Julianne C. "Starting Right: Strategies for Engaging Young Literacy Learners." In *Reading Engagement: Motivating Readers through Integrated Sources*. Ed. John T. Guthrie and Allan Wigfield. Newark, DE: International Reading Association, 1997.
- United Nations Educational, Scientific and Cultural Organization (UNESCO). *Le développement durable grace a l'education relative a l'environnement, Connexion* 13.2. Paris, France: UNESCO, June 1988.
- van Zee, E.H., and J.A. Minstrell. "Reflective Discourse: Developing Shared Understandings in a Physics Classroom." *International Journal of Science Education* 19 (1997): 209-228.
- Weinberg, Steven. "A Unified Physics by 2050?" *Scientific American* (Dec. 1999): 68-73.
- White, B.Y., and J.R. Frederiksen. "Inquiry, Modeling, and Metacognition: Making Science Accessible to All Students." *Cognition and Instruction* 16.1 (1998): 3-118.
- Wiggins, Grant. "What Is a Rubric? A Dialogue on Design and Use." In *Student Performance Assessment in the Era of Restructuring*. Ed. Robert E. Blum and Judith A. Arter. Alexandria, VA: ASCD Vi. 5, 1995.
- Williams, Robin. *The Non-Designer's Design Book: Design and Typographic Principles for the Visual Novice*. Berkeley, CA: Peachpit Press, 1994.

Willis, Scott. *Interdisciplinary Learning: Movement to Link the Disciplines Gains Momentum, Curriculum Update*. Alexandria, VA: Association for Supervision and Curriculum Development, November 1992.

Wood, D., J. Bruner, and G. Ross. "The Role of Tutoring in Problem Solving." *Journal of Child Psychology and Psychiatry* 17 (1976): 89–100.

## NOTES



Printed in Canada  
Imprimé au Canada