

Kindergarten to Grade 4 Science

A Foundation for
Implementation

**Manitoba
Education
and Training**
Drew Caldwell,
Minister



***KINDERGARTEN TO GRADE 4
SCIENCE***

A Foundation for Implementation

1999

Manitoba Education and Training

Manitoba Education and Training Cataloguing in Publication Data

372.35043 Kindergarten to Grade 4 science : a foundation
for implementation

(Renewing education : new directions)

Includes bibliographical references.
ISBN 0-7711-2298-5

1. Science—Study and teaching—Manitoba.
2. Science—Manitoba—Curricula. I. Manitoba.
Dept. of Education and Training. II. Series

Copyright © 1999, the Crown in Right of Manitoba as represented by the Minister of Education and Training. Manitoba Education and Training, School Programs Division, 1970 Ness Avenue, Winnipeg, Manitoba R3J 0Y9.

Every effort has been made to acknowledge original sources and to comply with copyright law. If cases are identified where this has not been done, please inform Manitoba Education and Training. Errors or omissions will be corrected in a future edition.

Parts of this publication have been adapted or reproduced from *The Ontario Curriculum, Grades 1–8: Science and Technology* © Queens Printer for Ontario, 1998. Reproduced with permission.

ACKNOWLEDGEMENTS

Manitoba Education and Training gratefully acknowledges the contributions of the following individuals in the development of *Kindergarten to Grade 4 Science: A Foundation for Implementation*.

Members of the Manitoba Development Team for *Kindergarten to Grade 4 Science: A Foundation for Implementation*

Brendene Barkley	Prince Edward School	River East S.D. No. 9
Heather Burdeniuk	Sansome School	St. James-Assiniboia S.D. No. 2
Dan Forbes	Ste. Anne Elementary School	Seine River S.D. No. 14
Clarence Kelly	William Whyte School	Winnipeg S.D. No. 1
Judy Kyliuk	Dalhousie School	Fort Garry S.D. No. 5
Barb McMillan	Faculty of Education	University of Manitoba
Elizabeth Mantler	Springfield Heights School	River East S.D. No. 9
Sandy Margetts	Faculty of Education	Brandon University
Daryl Shipman	Gladstone Elementary School	Pine Creek S.D. No. 30
Barb Wall	Donwood School	River East S.D. No. 9
Kathy Welsh	Mary Montgomery School	Fort La Bosse S.D. No. 41
Leslie Wurtak	Bairdmore School	Fort Garry S.D. No. 5

Writer

Dianne Soltess	St. James-Assiniboia S.D. No. 2
----------------	---------------------------------

Special Contributors

Jan Foster	Oakenwald School	Fort Garry S.D. No. 5
Eileen Froelich	Child Guidance Clinic	Winnipeg S.D. No. 1

Kindergarten to Senior 4 Science Overview Committee

Julie Bacon	École Oak Park	Assiniboine South S.D. No. 3
George Bush	St. James-Assiniboia S.D. No. 2	St. James-Assiniboia S.D. No. 2
Hélène Desrosiers	École Lagimodière	Division scolaire franco-manitobaine n° 49
Dan Forbes	Ste. Anne Elementary School	Seine River S.D. No. 14
Georges Kirouac	Collège régional Gabrielle-Roy	Division scolaire franco-manitobaine n° 49
Judy Kyliuk	Dalhousie School	Fort Garry S.D. No. 5
Coleen McKellar	Vincent Massey High School	Brandon S.D. No. 40
Don Metz	Collegiate, University of Winnipeg	Independent
John Murray	St. Boniface Diocesan High School	Independent
Gerald Rosner	Garden City Collegiate	Seven Oaks S.D. No. 10
Barb Wall	Donwood School	River East S.D. No. 9
Leslie Wurtak	Bairdmore School	Fort Garry S.D. No. 5

Kindergarten to Senior 4 Science Steering Committee

Ron Banister	Manitoba Teachers' Society	Winnipeg S.D. No. 1
Andy Burzynski	Red River College	Red River Community College
Brenda Craig	Wellington School	Winnipeg S.D. No. 1
Jan Foster	Oakenwald School	Fort Garry S.D. No. 5
Loreen Jackson	Manitoba Association of School Trustees	Rolling River S.D. No. 39
Vivian Jacob	Manitoba Association of Parent Councils	Transcona-Springfield S.D. No. 12
John Kozelko	Science Teachers' Association of Manitoba	Winnipeg S.D. No. 1 (from Fall 1998)
Guy Lacroix	Manitoba Association of School Superintendents	Seine River S.D. No. 14 (from Fall 1998)
Wade McMahon	Science Teachers' Association of Manitoba	Winnipeg S.D. No. 1 (from Fall 1998)
David Mackie	R. D. Parker Collegiate	Mystery Lake S.D. No. 2355
Lloyd Paulson	Manitoba Association of School Superintendents	Souris Valley S.D. No. 42 (from Fall 1998)
Cathy Philipson	Manitoba Association of Principals	Lord Selkirk S.D. No. 11 (from Fall 1998)
Gordon Robinson	Faculty of Science	University of Manitoba
Chris Shoemith	F. W. Gilbert School	Whiteshell S.D. No. 2408
Rick Skarban	Manitoba Association of Principals	Mystery Lake S.D. No. 2355 (from Fall 1998)
Arthur Stinner	Faculty of Education	University of Manitoba

**Manitoba Education and Training
School Programs Division Staff**

Lee-Ila Bothe	Coordinator	Production Support Unit Program Development Branch
Diane Cooley	Project Manager	Curriculum Unit Program Development Branch
Paul Cuthbert	Consultant	Learning Technologies Unit Program Development Branch
Amy Karlinsky	Publications Editor	Production Support Unit Program Development Branch
Janet Long	Desktop Publisher	Production Support Unit Program Development Branch
Grant Moore	Desktop Publisher	Production Support Unit Program Development Branch
Aileen Najduch	Project Leader	Curriculum Unit Program Development Branch
Tim Pohl	Desktop Publisher	Production Support Unit Program Development Branch

TABLE OF CONTENTS

Acknowledgements	<i>iii</i>
Table of Contents	<i>v</i>
Introduction	<i>1</i>
Background	<i>1</i>
Contents	<i>1</i>
Purpose	<i>2</i>
Overview	<i>3</i>
Characteristics of the Early Years Learner	<i>3</i>
A Meaningful Learning Environment for All	<i>4</i>
Assessment	<i>5</i>
Scientific Literacy	<i>9</i>
The Foundations for Scientific Literacy	<i>9</i>
Achieving Scientific Literacy through Student Learning Outcomes	<i>11</i>
Scientific and Technological Skills and Attitudes	<i>12</i>
Scientific Inquiry	<i>16</i>
Design Process	<i>18</i>
Planning for Instruction	<i>23</i>
An Integrated Approach	<i>23</i>
Planning Instructional Units	<i>25</i>
Guidelines for Planning	<i>27</i>
Planning Think-Aloud	<i>28</i>
Document Organization	<i>32</i>
The Four Column Format	<i>32</i>
Science Specific Learning Outcomes	<i>34</i>
Kindergarten	
Cluster 1: Trees	<i>K.1</i>
Cluster 2: Colours	<i>K.11</i>
Cluster 3: Paper	<i>K.23</i>
Grade 1	
Cluster 1: Characteristics and Needs of Living Things	<i>1.1</i>
Cluster 2: The Senses	<i>1.19</i>
Cluster 3: Characteristics of Objects and Materials	<i>1.37</i>
Cluster 4: Daily and Seasonal Changes	<i>1.49</i>
Grade 2	
Cluster 1: Growth and Changes in Animals	<i>2.1</i>
Cluster 2: Properties of Solids, Liquids, and Gases	<i>2.21</i>

Cluster 3: Position and Motion	2.49
Cluster 4: Air and Water in the Environment	2.69

Grade 3

Cluster 1: Growth and Changes in Plants	3.1
Cluster 2: Materials and Structures	3.17
Cluster 3: Forces That Attract or Repel	3.33
Cluster 4: Soils in the Environment	3.57

Grade 4

Cluster 1: Habitats and Communities	4.1
Cluster 2: Light	4.19
Cluster 3: Sound	4.39
Cluster 4: Rocks, Minerals, and Erosion	4.59

Appendices

Appendix A: General Learning Outcomes (from Framework)	A.1
Appendix B: Selecting Science-Based Literature	A.3
Appendix C: The Manitoba Clean Water Guide: What You Can Do	A.4
Appendix D: Pets in the Classroom	A.6
Appendix E: Using Learning Centres in the Science Classroom	A.9

References R.1**Blackline Masters**

BLM 1: Scientific Inquiry Recording Sheet: Grades 1 and 2
BLM 2: Scientific Inquiry Recording Sheet: Grades 3 and 4
BLM 3: Design Process Recording Sheet: Grades 1 and 2
BLM 4a: Design Process Recording Sheet: Grades 3 and 4
BLM 4b: Design Process Recording Sheet: Grades 3 and 4
BLM 5: How I Worked in My Group
BLM 6: How We Worked Together
BLM 7: Student Observation Record
BLM 8: Student Evaluation Sheet
BLM 9: Checklist
BLM 10: Food Sorting Cards
BLM 11: Animal Sorting Cards
BLM 12: Geologic Map of Canada
BLM 13: Geologic Map of Canada: Student Version
BLM 14: Geologic Map of Manitoba
BLM 15: Geologic Map of Manitoba: Student Version

INTRODUCTION

Background

Kindergarten to Grade 4 Science: A Foundation for Implementation was produced by Manitoba Education and Training in collaboration with a development team composed of Manitoba educators. This resource for teachers and administrators provides support for implementing *Kindergarten to Grade 4 Science: Manitoba Curriculum Framework of Outcomes* (1999). This framework identifies general and specific student learning outcomes for science and integrates the four foundation skill areas of literacy and communication, problem solving, human relations, and technology. It is mandated for use in all Kindergarten to Grade 4 schools in Manitoba.

Contents

Kindergarten to Grade 4 Science: A Foundation for Implementation contains the following sections:

- **Introduction** — The introduction describes the background, contents, and purpose of this document.
- **Overview** — The overview describes characteristics of the Early Years learner and instructional implications for teachers. It also discusses student diversity in the classroom and the use of differentiated instruction to foster meaningful learning experiences for all. In addition, this section highlights the characteristics of effective assessment and discusses specific assessment strategies.
- **Scientific Literacy** — This section presents a vision for scientific literacy and describes how the general and specific student learning outcomes help to define that vision. A chart showing the division of specific learning outcomes into clusters for each grade is provided. Two essential processes for scientific literacy — scientific inquiry and design process — are described in detail.
- **Planning for Instruction** — This section describes the importance of interdisciplinary teaching units and provides tools for planning science-based units of instruction.
- **Document Organization** — This section explains how to read the four-column format and the codes for the prescribed learning outcomes.
- **Suggestions for Instruction, Teacher Notes, and Suggestions for Assessment** — This four-column section contains the prescribed student learning outcomes, suggestions for instruction, teacher notes, and suggestions for assessment. It is organized by grade and is further divided into clusters or thematic units.
- **Appendices** — The five appendices provide additional information related to general student learning outcomes, selection of science-based literature, water conservation, pets in the classroom, and science learning centres.
- **References** — The reference list consists of works used in the development of this document.
- **Blackline Masters (BLMs)** — This section provides blackline masters to support and enhance the instructional and assessment suggestions. General student recording sheets, assessment masters, and cluster-specific support materials are included.

Purpose

Kindergarten to Grade 4 Science: A Foundation for Implementation provides theoretical content about science instruction. It also provides educators with practical suggestions for planning instruction and assessment to support and monitor student progress and achievement of the prescribed student learning outcomes.

OVERVIEW

Characteristics of the Early Years Learner

Kindergarten to Grade 2

Early Years students from Kindergarten to Grade 2 have a natural curiosity about the world around them. They explore their world through their senses, as well as by watching and imitating others. They are strongly influenced by the adults in their lives.

At this stage of the Early Years, students are highly involved in their own inquiries, based on their guesses about how things work and act. Consciously and unconsciously, they sort, group, order, and pair objects in both their work and play. These experiences help students learn about how things are alike or different. Talking with students as they explore helps to reinforce basic science concepts and encourages students to express themselves using accurate scientific terms.

To solve complex problems, Kindergarten to Grade 2 students require sufficient time to work through the problems step-by-step, using a trial and error approach. Adults need to resist the urge to correct student errors during this problem-solving process, allowing students to work through the errors and learn from them. Students construct their own understandings through interactions with living things, objects, and events in the world and from talking about what they did and what they found out. Technological problem solving (design process) provides an excellent mechanism for students to develop problem-solving skills while working with real-life problems and concrete materials.

Kindergarten to Grade 2 students tend to be somewhat egocentric. Group work, sharing of materials and tasks, and listening to others' ideas and suggestions can be difficult for them. Providing opportunities and establishing supports and guidelines for group work helps students learn to take turns and engage in positive social interactions. The use of science centres provides students with opportunities to develop these group-work skills. For more information, refer to Appendix E: Using Learning Centres in the Science Classroom.

Students at these grades find stories that follow linear sequences easy to understand and remember (e.g., stories about seasons, human growth, and activities of an insect/animal over the course of a day). These stories can be useful teaching tools in science. See Appendix B: Selecting Science-Based Literature for more information about the role of science-based learning resources in the Early Years classroom.

Grades 3 and 4

At Grades 3 and 4, students' views of the world broaden. Their thinking is more comprehensive and tends to be based on a rationale or on logic. Students move from simple matching to more complex ways of classifying.

At these grades, students' communication skills also broaden. Students are able to make simple notes, record data, and express themselves clearly in journals and learning logs. By Grade 3, students are less egocentric and are able to work well with a partner and in small groups. Science centres promoting exploration continue to provide effective learning experiences for students.

Students at Grades 3 and 4 are able to see cause and effect relationships and begin to make simple predictions. They also start to see the cyclical nature of phenomena (e.g., life cycles, the water cycle) rather than taking a linear approach to thinking. Students are now able to design simple experiments, carry them out, analyze the results, and present their findings.

Instructional Implications for Teachers

Kindergarten to Grade 4 science teachers have marvellous opportunities to stimulate their students' innate curiosity about the world around them. Teachers do not merely disseminate information; they facilitate student progress and achievement in learning. A stimulating classroom environment prompts students to ask challenging science questions that teachers may not be able to answer immediately. Effective teachers view these situations as opportunities to work with their students to find answers. It is important that students see teachers as lifelong learners.

A Meaningful Learning Environment for All

Diversity in the Classroom

Students come from a variety of backgrounds and have distinct learning requirements, learning and thinking approaches, and prior knowledge and experiences. Their depth of prior knowledge varies, reflecting their varied experiences inside and outside the classroom. Some entry-level knowledge held by students may be limited or incorrect, impeding new learning. For new learning to occur, it is important for teachers to activate prior knowledge, correct misconceptions, and encourage students to relate new information to prior experiences.

Manitoba's cultural diversity provides opportunities for embracing a wealth of culturally significant references and learning resources in the Early Years science classroom. Students from various backgrounds bring socially constructed meanings, references, and values to science learning experiences, as well as their unique learning approaches. As noted in the *Senior Years Science Teacher's Handbook*, "To be effective, the classroom must reflect, accommodate, and embrace the cultural diversity of its students" (1997, p. 7.13).

Toward this end, *Kindergarten to Grade 4 Science: A Foundation for Implementation* acknowledges and supports cultural diversity. Included in this document are a range of instructional strategies and conceptual links to appropriate communities and their resources, such as Aboriginal communities and agricultural communities. Teachers are encouraged to utilize the community environment and the surrounding natural habitats as these relate to particular science clusters throughout the grades. They afford opportunities to enrich the learning experience. The careful selection of learning resources that acknowledge cultural, racial, and gender differences will allow students to affirm and strengthen their unique social, cultural, and individual identities. A meaningful learning environment for all requires that teachers be sensitive to the role that diversity plays in the Early Years classroom.

Differentiating Instruction

Early Years science teachers continually ask themselves how they can meet each student's learning requirements and still make learning experiences challenging and meaningful for all. One way to help all students achieve the prescribed student learning outcomes for their grade is to differentiate the instructional strategies. (See *Success for All Learners: A Handbook on Differentiating Instruction*, 1996.) Through differentiating instruction, teachers can

- activate students' prior knowledge
- accommodate multiple intelligences and the variety of learning and thinking approaches
- help students interpret, apply, and integrate information

- facilitate the transfer of knowledge, skills, and attitudes to students' daily lives
- challenge students to realize academic and personal progress and achievement

Differentiating instruction does not mean offering a different program to each student. Classroom experiences can be differentiated by offering students choices and by varying instructional and assessment strategies to provide challenging and effective learning experiences for all.

Kindergarten to Grade 4 Science: A Foundation for Implementation includes cross-references to “Strategies That Make a Difference” in *Kindergarten to Grade 4 English Language Arts: A Foundation for Implementation* (1998); and *Success for All Learners: A Handbook on Differentiating Instruction* (1996). Teachers can refer to these documents for further information. Strategies that can be used effectively in the Early Years science classroom include graphic organizers (such as mind maps), knowledge charts that utilize students' prior knowledge, collaborative activities in brainstorming for solutions to design problems, information-processing strategies, science learning logs, and many others.

Learning Phases

Differentiated instructional strategies can be used in relation to the three learning phases:

- activating (preparing for learning)
- acquiring (integrating and processing learning)
- applying (consolidating learning)

These phases of learning are not entirely linear, nor are they discrete; rather, they provide teachers with a useful way of thinking and planning.

- The activating phase helps identify students' prior knowledge.
- The acquiring phase helps students to integrate new information with what they already know, adding or revising their previous knowledge as needed. Teachers help students make meaning of new information.
- The applying phase allows students to reflect on what they have learned, apply their learning in new situations, and extend their learning by drawing connections to other subject areas.

For a discussion of these three learning phases see Chapter 6, *Success for All Learners*.

Assessment

Assessment is “the systemic process of gathering information about what a student knows, is able to do, and is learning to do” (*Reporting on Student Progress and Achievement*, 1997, p. 38). Assessment involves collecting, interpreting, and communicating results related to students' progress and achievement.

In Early Years science, as in other subject areas, effective assessment is

- an integral part of instruction and learning
- continuous and ongoing
- a collaborative and reflective process
- authentic and reflective of meaningful science-learning processes and contexts
- developmentally and culturally appropriate

- focussed on students' strengths
- multi-dimensional
- based on how students learn

(Adapted from *Kindergarten to Grade 4 English Language Arts: A Foundation for Implementation*, 1998, p. 249.)

This view of effective assessment in science for Manitoba is reflective of changes in emphases in science education at the national level and is congruent with international changes in science education. The following chart summarizes, at a glance, some of the changes in the area of assessment.

Changing Emphases *

The *National Science Education Standards* envision change throughout the system. The assessment standards encompass the following changes in emphases:

LESS EMPHASIS ON

Assessing what is easily measured
 Assessing discrete knowledge
 Assessing scientific knowledge
 Assessing to learn what students do not know
 Assessing only achievement
 End of term assessments by teachers
 Development of external assessments by measurement experts alone

MORE EMPHASIS ON

Assessing what is most highly valued
 Assessing rich, well-structured knowledge
 Assessing scientific understanding and reasoning
 Assessing to learn what students do understand
 Assessing achievement and opportunity to learn
 Students engaged in ongoing assessment of their work and that of others
 Teachers involved in the development of external assessments

Formative and Summative Assessment

Assessment can be formative or summative.

- **Formative assessment** is based on data collected before an instructional unit is completed. Its purpose is to improve instruction and learning by
 - providing students and teachers with information about students' progress in accomplishing prescribed learning outcomes
 - evaluating the effectiveness of instructional programming content, methods, sequence, and pace
- **Summative assessment** (evaluation) is based on an interpretation of the assessment information collected. It helps determine the extent of each student's achievement of prescribed learning outcomes. Evaluation should be based on a variety of assessment information. Summative assessment is used primarily to
 - measure student achievement

* Source: *National Science Education Standards*, p. 25. © 1996 by The National Academy of Sciences. Reproduced with permission of the National Academy Press.

- report to parent(s)/guardian(s), students, and other stakeholders
- measure the effectiveness of instructional programming

Kindergarten to Grade 4 Science: A Foundation for Implementation suggests a range of assessment strategies. The same strategy can be used for both formative and summative assessment, depending on the purpose of the assessment.

A detailed discussion of the suggested assessment strategies included in this document follows:

- **Observation** — Observation of students is an integral part of the assessment process. It is most effective when focussed on skills, concepts, and attitudes. Without record keeping, however, observations and conversations can easily be forgotten. Making brief notes on index cards, self-stick notes or grids, as well as keeping checklists, helps teachers maintain records of continuous progress and achievement. (Refer, for example, to BLM 7: Student Observation Record, BLM 8: Student Evaluation Sheet, and BLM 9: Checklist.)
- **Interviews** — Interviews allow teachers to assess an individual’s understanding and achievement of the prescribed student learning outcome(s). Interviews provide students with opportunities to model and explain their understandings. Interviews may be both formal and informal. Posing science-related questions during planned interviews enables teachers to focus on individual student skills and attitudes. Questioning students about how they solved problems or answered science questions reveals their thinking processes and their use of skills. Using a prepared set of questions ensures that all interviews follow a similar structure. It is important to keep a record of student responses and/or understandings.
- **Group/Peer Assessment** — Group assessment gives students opportunities to assess how well they work within a group. Peer assessment gives them opportunities to reflect on one another’s work, according to clearly established criteria. During the peer assessment process, students must reflect on their own understanding in order to evaluate the performance of another student.
- **Self-Assessment** — Self-assessment is vital to all learning and, therefore, integral to the assessment process. Each student should be encouraged to evaluate her/his own work. Students apply known criteria and expectations to their work and reflect on results to determine their progress toward the mastery of a prescribed learning outcome. Participation in setting self-assessment criteria and expectations helps students to see themselves as scientists and problem solvers. It is important that the teacher model the self-assessment process before expecting students to assess themselves. (Refer to BLM 5: How I Worked in My Group.)
- **Performance Tasks** — Performance tasks provide students with opportunities to demonstrate their knowledge and thinking processes. The tasks require the application of knowledge and skills related to a group of student learning outcomes. A scoring rubric that includes a scale for the performance of the task helps organize and interpret evidence. Rubrics allow for a continuum of performance levels associated with the task being assessed.

- **Science Journal/Learning Log Entries** — Science journal writing and learning log entries provide opportunities for students to reflect on their learning and to demonstrate their understanding using pictures, labelled drawings, and words. These can be powerful tools of formative assessment, allowing teachers to gauge a student's depth of understanding. In this document direct questions/scenarios frame the science journal suggestions.
- **Paper and Pencil Tasks** — Paper and pencil tasks can be used as discrete assessment tools or as part of larger assessment experiences. Paper and pencil tasks may include items such as multiple choice questions, true or false questions, long answer questions, matching questions, and completion of a drawing or labelled diagram.

The foregoing assessment suggestions are not meant to be limiting. Teachers are strongly encouraged to develop their own assessment for Early Years science based on their students' learning requirements and the requirements of the prescribed student learning outcomes. *Reporting on Student Progress and Achievement: A Policy Handbook for Teachers, Administrators, and Parents* (1997) contains further information related to reporting on student progress.

SCIENTIFIC LITERACY

The Foundations for Scientific Literacy

Kindergarten to Grade 4 Science: A Foundation for Implementation is designed in accordance with the vision for scientific literacy articulated in the *Common Framework of Science Learning Outcomes K to 12: Pan-Canadian Protocol for Collaboration on School Curriculum* (1997) (hereafter referred to as the *Pan-Canadian Science Framework*).

The *Pan-Canadian Science Framework*

is guided by the vision that all Canadian students, regardless of gender or cultural background, will have an opportunity to develop scientific literacy. Scientific literacy is an evolving combination of the science-related attitudes, skills, and knowledge. Students need to develop inquiry, problem-solving, and decision-making abilities, to become lifelong learners, and to maintain a sense of wonder about the world around them.

Diverse learning experiences based on the [Pan-Canadian] framework will provide students with many opportunities to explore, analyze, evaluate, synthesize, appreciate, and understand the interrelationships among science, technology, society, and the environment that will affect their personal lives, careers, and their future. (p. 4)

To develop scientific literacy, science learning experiences must incorporate the essential aspects of science and its related applications. These essential aspects, the foundations for scientific literacy, have been adapted from the *Pan-Canadian Science Framework* to address the needs of Manitoba students. Manitoba science curricula are built upon the following five foundations for scientific literacy:

- A. Nature of Science and Technology
- B. Science, Technology, Society, and Environment (STSE)
- C. Scientific and Technological Skills and Attitudes
- D. Essential Science Knowledge
- E. Unifying Concepts

For more background on each of these foundation areas, consult *Kindergarten to Grade 4 Science: Manitoba Curriculum Framework of Outcomes* (1999) (hereafter referred to as *K–4 Science Manitoba Framework*).

Manitoba's vision for scientific literacy, as reflected in the five foundation areas, represents a paradigm shift in science education also evident across North America and Western Europe. The chart on the following page highlights some areas in which there are changing emphases.

CHANGING EMPHASES*

The *National Science Education Standards* envision change throughout the system. The science content standards [or student learning outcomes] encompass the following changes in emphases:

LESS EMPHASIS ON

Knowing scientific facts and information

Studying subject matter disciplines (physical, life, earth sciences) for their own sake

Separating science knowledge and science process

Covering many science topics

Implementing inquiry as a set of processes

MORE EMPHASIS ON

Understanding scientific concepts and developing abilities of inquiry

Learning subject matter disciplines in the context of inquiry, technology, science in personal and social perspectives, and history and nature of science

Integrating all aspects of science content

Studying a few fundamental science concepts

Implementing inquiry as instructional strategies, abilities, and ideas to be learned

CHANGING EMPHASES TO PROMOTE INQUIRY

LESS EMPHASIS ON

Activities that demonstrate and verify science content

Investigations confined to one class period

Process skills out of context

Emphasis on individual process skills such as observation or inference

Getting an answer

Science as exploration and experiment

Providing answers to questions about science content

Individuals and groups of students analyzing and synthesizing data without defending a conclusion

Doing few investigations in order to leave time to cover large amounts of content

Concluding inquiries with the result of the experiment

Management of materials and equipment

Private communication of student ideas and conclusions to teacher

MORE EMPHASIS ON

Activities that investigate and analyze science questions

Investigations over extended periods of time

Process skills in context

Using multiple process skills—manipulation, cognitive, procedural

Using evidence and strategies for developing or revising an explanation

Science as argument and explanation

Communicating science explanations

Groups of students often analyzing and synthesizing data after defending conclusions

Doing more investigations in order to develop understanding, ability, values of inquiry and knowledge of science content

Applying the results of experiments to scientific arguments and explanations

Management of ideas and information

Public communication of student ideas and work to classmates

* Source: *National Science Education Standards*, p. 18. © 1996 by the National Academy of Sciences. Reproduced with permission of the National Academy Press.

Achieving Scientific Literacy through Student Learning Outcomes

General student learning outcomes (GLOs) for Manitoba, based on the five foundation areas, define overall expectations for scientific literacy from Kindergarten to Senior 4. Appendix A: General Learning Outcomes includes a complete list of GLOs, excerpted from *K–4 Science Manitoba Framework*. Specific student learning outcomes (SLOs) that further define expectations for student achievement at each grade are also included in this document.

Specific student learning outcomes for Kindergarten to Grade 4 science are arranged in clusters. Clusters 1 to 4 are thematic groupings that generally correspond to disciplinary distinctions within science, including life science, physical science, and Earth and space science. (Note: Kindergarten has only three thematic clusters.) Specific student learning outcomes included in Cluster 0 address the overall science skills and attitudes students are expected to achieve. For a full listing of Cluster 0 student learning outcomes, consult *K–4 Science Manitoba Framework* or the Overall Skills and Attitudes Chart Kindergarten to Grade 4 science included with this document.

Cluster Titles

	K	Grade 1	Grade 2	Grade 3	Grade 4
Cluster 0	Overall Skills and Attitudes (to be integrated into Clusters 1 to 4)				
Cluster 1	Trees	Characteristics and Needs of Living Things	Growth and Changes in Animals	Growth and Changes in Plants	Habitats and Communities
Cluster 2	Colours	The Senses	Properties of Solids, Liquids, and Gases	Materials and Structures	Light
Cluster 3	Paper	Characteristics of Objects and Materials	Position and Motion	Forces that Attract or Repel	Sound
Cluster 4	N/A	Daily and Seasonal Changes	Air and Water in the Environment	Soils in the Environment	Rocks, Minerals, and Erosion

Scientific and Technological Skills and Attitudes

Science education, with scientific literacy as its goal, must engage students in scientific inquiry, technological problem solving (design process), and decision making. These skills, behaviours, and attitudes are essential for the development of scientific understanding and the application of science and technology to new situations. Cluster 0 from *K–4 Science Manitoba Framework* identifies student learning outcomes related to scientific inquiry and technological problem solving (design process), as well as those that apply to both processes. For some educators, this way of conceptualizing science will be new. Yet, the increasing importance of technology in daily life and the need for critical problem-solving skills underscore the importance of integrating basic science concepts with skills and attitudes related to scientific inquiry and the design process.

The following figure, adapted from Alberta Education, illustrates some differences and similarities between scientific inquiry and the design process in purpose, procedure, and product. As teachers plan for the integration of student learning outcomes from Cluster 0: Overall Skills and Attitudes they will become more familiar with these two distinct processes as well as the overlapping skills involved.

Processes for Science Education*

	Scientific Inquiry	Design Process (Technological Problem Solving)
Purpose	satisfying curiosity about events and phenomena in the natural world	coping with everyday life practices, and human needs
Procedure	What do we know? What do we want to know?	How can we do it? Will it work?
Product	knowledge about events and phenomena in the natural world	an effective and efficient way to accomplish a task or meet a need

	Scientific Question	Technological Design Problem
Example	Why does my coffee cool so quickly? <i>An answer:</i> Heat energy is transferred by conduction, convection, and radiation.	How can I keep my coffee hot? <i>An answer:</i> One solution is to develop a styrofoam cup that will keep liquids warm for a long time.

* Source: Science-Technology—STSE Chart. Adapted with permission of the Minister of Education, Province of Alberta, Canada, 1999.

As shown in the accompanying poster, Overall Skills and Attitude Chart Kindergarten to Grade 4 Science, the specific student learning outcomes in Cluster 0 are identified as applying to scientific inquiry, the design process, or both (see example). The scientific inquiry elements are included in black type on a white box on the left. The design process elements are clearly identified by the use of white type on a black box on the right. Learning outcomes related to both processes are located in a horizontal box below the left and right hand boxes. All specific student learning outcomes appear in a numbered and lettered sequence, e.g., 1a., 1b., 1c., 2a., 2b., etc.

Grade 2	
Scientific Inquiry	Design Process
<p>1a. Ask questions that lead to investigations of living things, objects, and events in the immediate environment. (ELA 1.2.4, 3.1.2, 3.1.3; Math SP-I.1.2) GLO: A1, C2, C5</p> <p>1b. Make predictions based on observed patterns or on collected data. (ELA 1.1.1, 1.2.1) GLO: A1, C2</p>	<p>1c. Identify practical problems to solve in the immediate environment. GLO: C3</p>
<p>2a. Access information using a variety of sources. <i>Examples: elders, simple chapter books, concept books, CD-ROMs, Internet...</i> (ELA 1.1.2, 3.2.2 Math SP-II.1.2; TFS 2.1.1) GLO: C6</p> <p>2b. Match information to research needs. (ELA 3.2.3, 3.3.3) GLO: C6, C8</p>	

These specific student learning outcomes are further organized into the following nine categories:

- | | |
|------------------------------------|---|
| 1. Initiating | 6. Analyzing and Interpreting |
| 2. Researching | 7. Concluding and Applying |
| 3. Planning | 8. Reflecting on Science and Technology |
| 4. Implementing a Plan | 9. Demonstrating Scientific and Technological Attitudes |
| 5. Observing, Measuring, Recording | |

The two graphics on the following pages illustrate the stages of scientific inquiry and the design process. Detailed descriptions of each process follow the graphics.

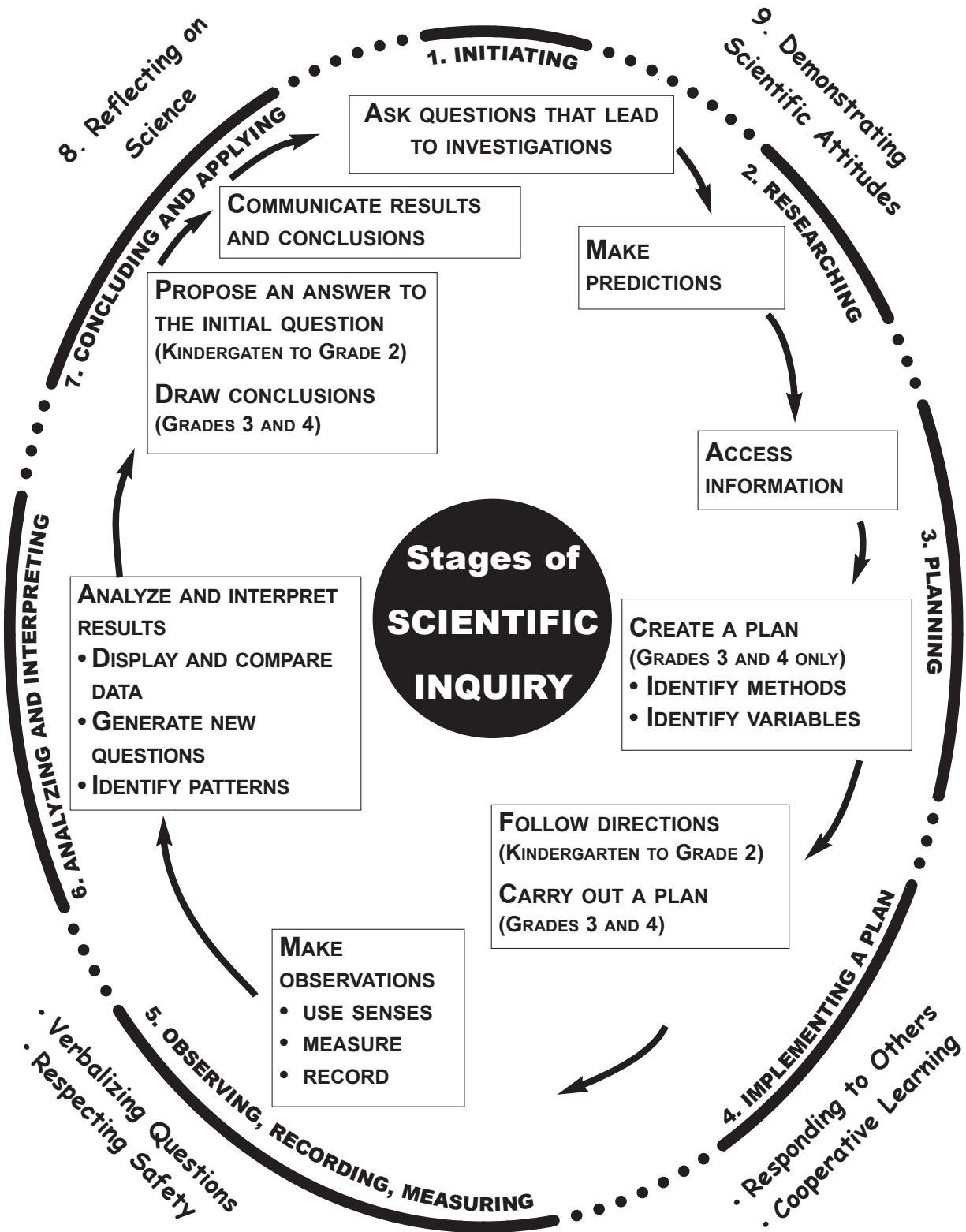

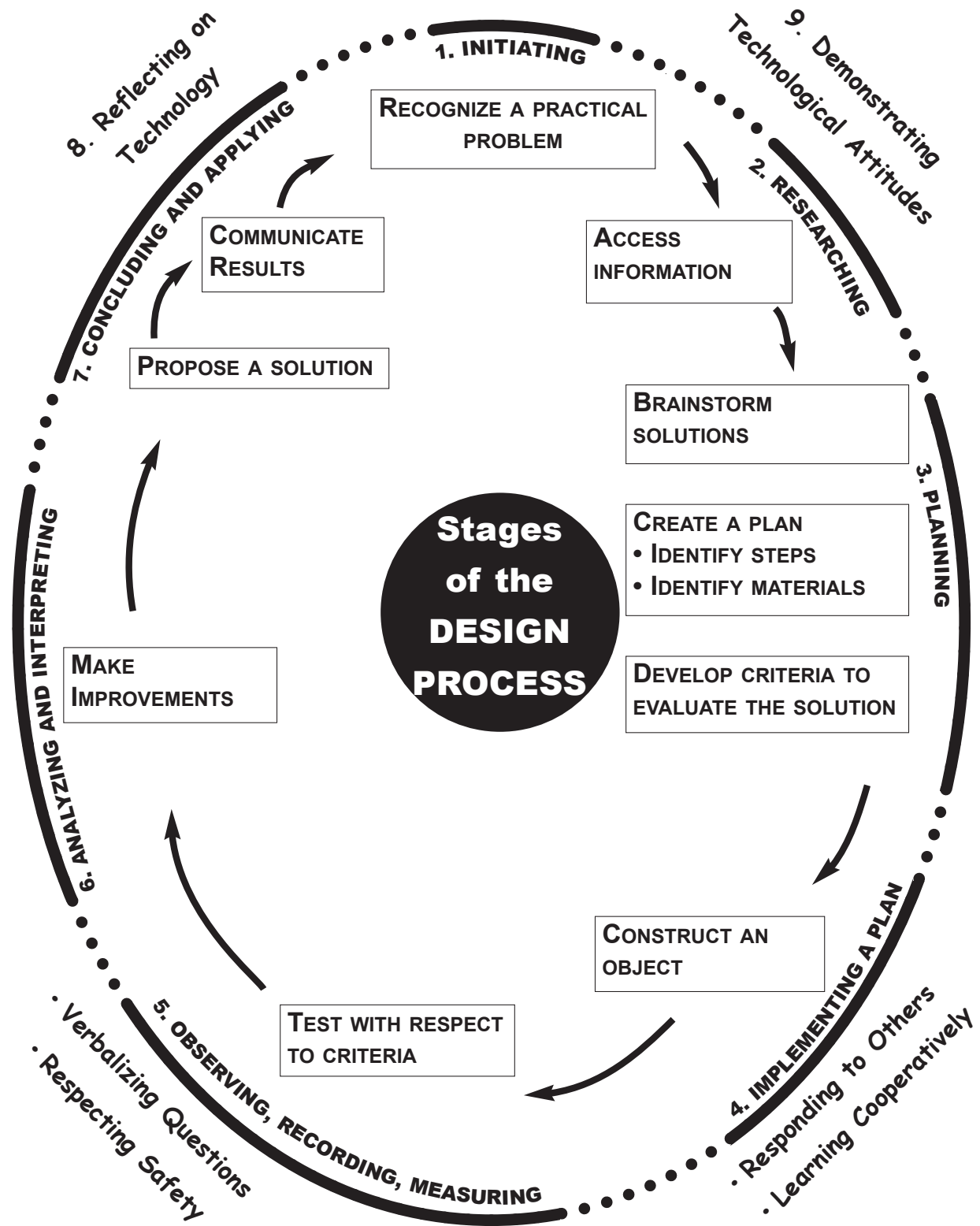

Scientific Inquiry

As indicated in the graphic on page 14, scientific inquiry generally proceeds according to a sequence of stages, although there will be differences in the order and number of stages the students undertake. With repetition and experience, students will become aware of the logical underpinnings of scientific inquiry and develop familiarity and fluency with the requisite skills and attitudes. While all grades follow the general stages of scientific inquiry, there are significant differences in expectations of students across the grades. In Kindergarten to Grade 2, the teacher manages the plan for the scientific inquiry and controls the variables. At these grades, the purpose of the scientific inquiry is to propose one answer to the initial question. By Grades 3 and 4, students work as a class to plan their own experiments and identify and control variables, carry out the experiments in small groups, and draw conclusions related to the initial question.

Stages of Scientific Inquiry

The stages of the scientific inquiry are discussed in detail below. It should be noted that these stages are general guidelines and every scientific inquiry may not address all stages or stages in the exact order provided here.

- **Asking Questions That Lead to Investigations** — Scientific inquiry begins with a child’s curiosity to explore his/her world. Active inquiry starts by asking questions that lead to “investigations of living things, objects, and events in the immediate environment” (*Kindergarten to Grade 4 Science Framework*, 3.26).
- **Making Predictions** — Using prior knowledge, observed patterns, and collected data, students develop ideas to predict possible answers to questions.
- **Accessing Information** — Accessing information is directly linked to SLO 3.2 for *K–4 ELA, Select and Process*. Using a variety of print, non-print, electronic, and human resources, students access information and match it to their inquiry or research needs.
- **Creating a Plan** — This stage of scientific inquiry begins at Grade 3. From Kindergarten to Grade 2, the teacher is responsible for planning scientific inquiry and controlling the variables. At Grades 3 and 4, students work with the class to create a plan to answer a given question and identify variables that need to be controlled. A variable is an object or quantity that can change. For example, learning outcome 3-1-04 expects students to *conduct experiments to determine conditions needed for healthy plant growth*. The conditions listed in the “include” portion of the learning outcome identify variables to be controlled — *light, water, air, space, warmth, growing medium, nutrient*. To test the impact of sunlight on plant growth, students need to ensure that all other variables such as water, air, space, warmth, growing medium, etc., are exactly the same for all plants. By controlling these variables, any changes in the plant can be attributed to different amounts of sunlight.
- **Following Directions (Kindergarten to Grade 2)/Carrying Out a Plan (Grades 3 and 4)** — At this inquiry stage, Kindergarten to Grade 2 students implement a plan, following specific directions. Students in Grades 3 and 4 carry out a plan following and describing a sequence of steps. These steps link directly to SLO 3.1.2 *K–4 ELA, Create and Follow a Plan*. Throughout this stage of scientific inquiry, students are involved in group collaboration, communication, and safety procedures and rules.

- **Making Observations** — During the observation process, students are involved in perceiving characteristics and changes using their senses. Measurement enables students to find the dimensions or quantity of an object and the duration of an event. At this stage, students develop skills in estimating size, mass, length, volume, and time and in selecting and using appropriate measuring devices. Observations can be recorded in a variety of ways. The language arts of *representing* and *writing* allow students to record data using tables, charts, pictures, simple labelled diagrams, flowcharts, sentences, and simple reports.
- **Displaying and Comparing Data** — Students can use pictures or labelled diagrams, charts, graphs, etc. to display their data. These means of organization facilitate data comparison. Through this comparison, students can generate new questions related to the data that may lead to further scientific inquiry. They may also begin to see patterns in the data that help them answer questions or draw conclusions.

This inquiry stage is directly linked to mathematical skills. To facilitate this interdisciplinary integration, references are made to learning outcomes from *Kindergarten to Grade 4 Mathematics: Manitoba Curriculum Framework of Outcomes and Grade 3 Standards* (1996).

- **Proposing an Answer/Drawing Conclusions** — From Kindergarten to Grade 2, students propose an answer to an initial question. This answer comes directly from the scientific inquiry itself. It is not dependent on students' applying prior scientific knowledge. For example, in the scientific inquiry related to learning outcome *K-2-05, Predict and describe changes in colour that result from the mixing of primary colours and from mixing a primary colour with white or black*, students are asked to determine which colours result when two or more primary colours are combined. The expected answers may include "red and blue make purple" or "yellow and blue make green." These statements are based directly on observations made in the inquiry itself.

At Grades 3 and 4, students begin to draw conclusions. The conclusions are based on the data collected from the scientific inquiry, as well as on data collected from other inquiries; patterns seen in data; and prior scientific knowledge or understandings. These conclusions are broader statements that can be applied beyond the boundaries of a specific scientific inquiry.

For example, in the scientific inquiry related to learning outcome *3-1-04, Conduct experiments to determine conditions needed for healthy plant growth*, students conduct a scientific inquiry to answer the question: "What do you think plants need to survive?" The subsequent analysis of their inquiry results, combined with their understanding of the needs of living things from Grade 1, Cluster 1, gives students an answer specifically related to the plants in their experiment. Students are then expected to generalize these findings to all plants in the form of a conclusion. For example: All plants require light, water, air, space, warmth, and nutrients in order to grow and remain healthy.

- **Communicating Results** — "In writing, speaking, and representing, students construct meaning in order to communicate with others" (*Kindergarten to Grade 4 English Language Arts: A Foundation for Implementation*, p. 10). Through photo essays, videos, sketchbooks, flow charts, oral presentations, illustrated reports, or demonstrations, students can communicate the findings and procedures of their scientific inquiry. They can share their thoughts related to the scientific inquiry process through group discussion.

Materials Required for Scientific Inquiry

From Kindergarten to Grade 4, the materials required for explorations and investigations are generally household items, classroom supplies, and recycled objects. At times, students use tools to enhance their observations. A listing of tools for each grade can be found in Cluster 0: Overall Skills and Attitudes.

Safety Considerations

Throughout Kindergarten to Grade 4, the primary responsibility for safety in science belongs to teachers and other school personnel. It is important, however, for students to become aware of the importance of safety measures regarding themselves, others, and the environment. It is essential to instill in every student's mind that safety must be a principal consideration in planning and carrying out scientific experiments, investigations, and explorations. This attitude is a critical component of the scientific culture of students who will become responsible citizens of the future.

Assessment

Students' application of the steps of the scientific inquiry process involves the acquisition of knowledge, skills, and behaviours. Like all other areas of the curriculum, scientific inquiry skills and attitudes should be assessed in relation to the prescribed student learning outcomes. (See page 5 for a general discussion on assessment.) Teachers need to identify and become familiar with Cluster 0 grade-level learning outcomes that focus on skills specific to scientific inquiry. These skills are difficult to assess in a paper and pencil format. They are best assessed through observations, interviews, and tasks that involve students in actively exploring, investigating, and experimenting.

Design Process

As indicated in the graphic on page 15, the design process consists of a series of sequenced stages. Many of these skills and attitudes in the design process will be new to Early Years students. Repetition and discussion will encourage familiarity with the stages and a broader understanding of technological problem solving.

While all grades follow the general stages of the design process shown above, there are significant differences in expectations of students across the grades. In Kindergarten to Grade 2, brainstorming and planning are generally done with the class. By Grade 3, students are brainstorming and planning in small groups. By Grade 4, they are able to carry out these activities independently. The level of sophistication of evaluation criteria for the finished product also changes over the grades. In Kindergarten to Grade 1 the criteria are limited to those related directly to function. In Grade 4, other considerations such as materials and cost take on greater significance.

Stages of the Design Process

The stages of the design process are discussed in detail below. It should be noted that these stages are general guidelines and every design task may not address all stages, or stages in the exact order provided here.

- **Recognizing a Practical Problem** — Recognizing a practical problem initiates the design process. For example, the practical problem for outcome 2.3.14, *Use the design process to construct a vehicle with wheels and axles that meet given criteria*, could be presented in the following manner:

Design and construct a vehicle with 4 wheels and 2 axles that can travel 2 metres across a surface by a push and include a container holding 15 marbles.

Teachers may want to limit materials to

- cardboard
- a selection of specified materials for wheels (e.g., plastic lids, film canisters, spools, cardboard circles, etc.)
- pencils, dowelling, and wooden skewers
- a selection of joining materials (e.g., glue, string, rubber bands, clips, staples, tape, etc.)

Limiting materials provides structure and guidance to the Early Years student who may be overwhelmed by the potential choices.

- **Researching/Accessing Information** — Gathering information is an integral part of the entire design process. Information is gathered in a number of ways from a variety of resources. The teacher’s task is to decide
 - what information will be needed
 - which learning resources are appropriate
 - what information is required to meet the student learning outcomes
 - what information-gathering skills and activities are appropriate to the task
 - what strategies are required for developing research skills

Gathering information requires individual and class discussion as well as effective teacher questioning that activates students’ prior knowledge and experiences and allows for the acquisition and integration of new knowledge. Class discussions will provide teachers with opportunities to identify students’ misconceptions and the need for further research.

- **Developing Evaluation Criteria** — Criteria must be specific enough to limit the scope of impractical solutions and ensure success, but also open-ended enough to allow originality and creativity. The criteria should be generated with student input. The teacher may specify criteria related to the specific learning outcome and available materials, but students can add other criteria. Student-developed criteria often relate to the real-world, such as, “the vehicle must contain a section for the driver and a steering wheel.”

Other categories of criteria that can be included are

- Aesthetics: For some solutions, aesthetics are a factor. The criterion of being “visually appealing” can be included, with student input as to the descriptors (e.g., colour, scale, etc.).
- Cost: By assigning a monetary value to materials or processes, cost efficiency can be addressed.
- Environmental Impacts: Criteria that focus on environmental impacts, sustainability, the effect of the design solution on the environment, and the STSE component of the science curriculum can be addressed.

- **Brainstorming Solutions** — Brainstorming first involves generating many ideas without evaluating them. It involves teacher questioning strategies to encourage fluency, flexibility, and the elaboration of ideas. Brainstorming assists students in the development of critical thinking skills, group communication, and interaction. The design team or student group will discuss the various ideas generated during brainstorming. An idea, which might be a combination of several ideas, is selected as the best possible solution to meet the need or problem.
- **Creating a Plan** — At this stage, the group decides on materials to implement their solution. The planned product should be sketched and labelled prior to construction. The selection of materials and the design will demonstrate students’ understanding of science knowledge and skills associated with the task. As a student gains experience in the design process, she or he will readily sketch the planned solution before making it. For younger students, the making will often come first, with a picture of the design following the construction. Teachers should encourage the visualization of the solution and model the sketching/labelling step.
- **Constructing an Object** — Making the design gives students experience in identifying the properties of materials and their uses. It provides opportunities to apply science knowledge and skills that have been developed through the particular science cluster.

For example, the design problem associated with specific learning outcomes 2.3.14, requires students to have experience with the workings and construction of wheels and axles (student learning outcomes 2.3.11-13) prior to constructing the solution. This may involve the use of structured activities using commercially available construction kits or building sets. The construction stage may involve the generation and revision of ideas and the identification of the need for further research. This could result in a solution that differs from the original design.

- **Testing with Respect to Evaluation Criteria** — Once the design problem has been solved, students must test the finished product or solution against the evaluation criteria specified earlier. The students self-evaluate and peer-evaluate their products and processes. They suggest ideas for improvement of the product. They reflect on the group interaction and the various stages of the design process.
- **Making Improvements** — From testing and evaluating the final product, students will be able to consider their design solutions in order to
 - make modifications
 - list modifications
 - revise the design sketch to reflect modifications
- **Proposing a Solution** — The design process concludes with the proposal of a solution that has been tested with respect to the evaluation criteria and that reflects improvements based on students’ analyses. New problems may also be identified, leading to the need for new product development.
- **Communicating Results** — “In writing, speaking, and representing, students construct meaning in order to communicate with others” (*K-4 ELA Foundation*, p. 10). Through photo essays, videos, design sketchbooks, flow charts, oral presentations, illustrated reports, or demonstrations, students can communicate the products and the procedures of their design process. It is important for students to share their thoughts related to the design process through group discussion.

Materials Required for the Design Process

Materials for a design task include recycled and everyday materials as well as construction kits. All have a place in the design process. When students first implement the design process in the science classroom, materials that are readily available, easily accessible, and familiar to students provide a good starting point.

Construction kits assist students in developing skills with tools and materials. Kits can be used as a medium for modelling or for open-ended exploration, prior to a specific design process learning experience.

For many design tasks, recycled materials such as newspapers, plastic drink bottles, string, boxes, etc., are sufficient. Supplemental items such as tape, glue sticks, straws, scissors, etc., will be needed as well. The use of recycled materials addresses the Science, Technology, Society, and the Environment (STSE) component of the curriculum.

It is important that students become familiar with the characteristics and properties of the materials they are using. Through open-ended exploration and discussion about materials, students gain knowledge about structural qualities. For certain design tasks, it is recommended that the materials be limited. This encourages students to explore and gain experience in the use and properties of specific materials and techniques by focussing their thinking.

At times, some tools will be required for constructing the solution/product. However, with the inclusion of design technology tasks in Early Years, many techniques have been adopted with young students in mind. For example, the use of materials such as cardboard triangles to join two pieces of wood replaces the need for hammers and nails.

Safety Considerations

The use of tools within the Early Years classroom raises safety concerns. As the teacher or school acquires specific tools for use in the design process, attention to the age of the students is important. Some suppliers who provide tools for the design technology component of the curriculum design these tools with the young user in mind. Low temperature glue guns, small bench hooks, mitre boxes, and safety goggles are a few such items. If cutting wood is required, it is important that students use hacksaws designed for the Early Years classroom, rather than bringing saws from home.

There are several methods to ensure safety in the classroom during the design process:

- Teach tool use. Demonstrate and have students practise safe use of the tools prior to beginning the task.
- Generate safety rules for the classroom, with the students developing the criteria whenever possible.
- Organize
 - the students (groupings, supervision, responsibilities)
 - the materials (storage, responsibilities)
 - the tools and equipment (storage, work area, student/teacher tools, supervision)
 - the design process display area
- Arrange the classroom for access to resources and equipment with safety in mind.

Assessment

Student learning outcomes for the design process, like all other areas of the curriculum, should be assessed for the acquisition of knowledge, skills, and behaviours. (See page 5 for a general discussion on assessment.) Teachers need to identify and become familiar with the grade-specific student learning outcomes in Cluster 0 that relate to the design process. Frequently, student learning can be assessed through teacher observation and questioning of students. Assessment should be based on the demonstration of learning that has taken place throughout the design process. Similarly, the solution should not be evaluated on whether it is right or wrong, but rather on the degree of its effectiveness in addressing the original problem.

Because of the sequential and recursive nature of the design process, student self-assessment and peer assessment should be ongoing. The design process also provides opportunities for formative assessment so that teachers can plan for the next stage of instruction and learning.

In the evaluation stage of the design process, assessment should focus on the positive aspects of the solution. Through the use of probing and open-ended questions, the teacher can elicit further thinking on the part of the student, as well as receive an indication about the student's level of achievement related to the learning outcomes. Design books, journals, and photo essays can provide records of each stage of the design process and assist in the assessment of student learning.

PLANNING FOR INSTRUCTION

An Integrated Approach

Effective science learning does not happen in isolation. Early Years students learn best by making connections within and among the different subject areas. Students need to understand the inter-relationships among the science outcomes within a grade, among grades, and with the every-day world. Throughout a unit of instruction, teachers should help students make these connections. Using an integrated approach allows teachers to make connections between the acquisition of skills and real world applications across the curriculum. Integration also helps teachers make the most efficient use of valuable teaching and learning time.

A thematic approach can be used to integrate the various subject areas. Using a science topic as a central focus can help students see their world through the eyes of a scientist. It can provide a meaningful context in which to apply and strengthen skills already acquired and to learn new skills in the different subject areas.

Science utilizes skills developed in other subject areas. Students need to be able to read and view science-related materials. They need to be able to listen in order to acquire information and benefit from the ideas of others. Speaking, writing, and representing are important so students can communicate their questions and understandings related to science. Students also need to be able to see patterns in the real world as well as in collected data. Measurement and number skills are important in making observations and in collecting and interpreting data. Students need skills in statistics in order to represent their data. Student learning is enhanced by the use of information technology in the science classroom both in acquiring information and communicating results.

To assist with integration, references to *Kindergarten to Grade 4 Mathematics: A Foundation for Implementation*, *Kindergarten to Grade 4 English Language Arts: A Foundation for Implementation*, and *Technology as a Foundation Skill Area: A Journey Toward Information Technology Literacy* have been made. Ideas for links to other areas such as art, music, Native studies, and social studies have been included. For general information on curricular integration, refer to *Curricular Connections: Elements of Integration in the Classroom* (1997). The following page contains a sample planning web for an integrated unit of instruction.

Web for a Science-Focussed Theme: An Integrated Approach

The following planning web on “Animal Growth and Change” demonstrates the use of a science theme that integrates student learning from other subject areas.

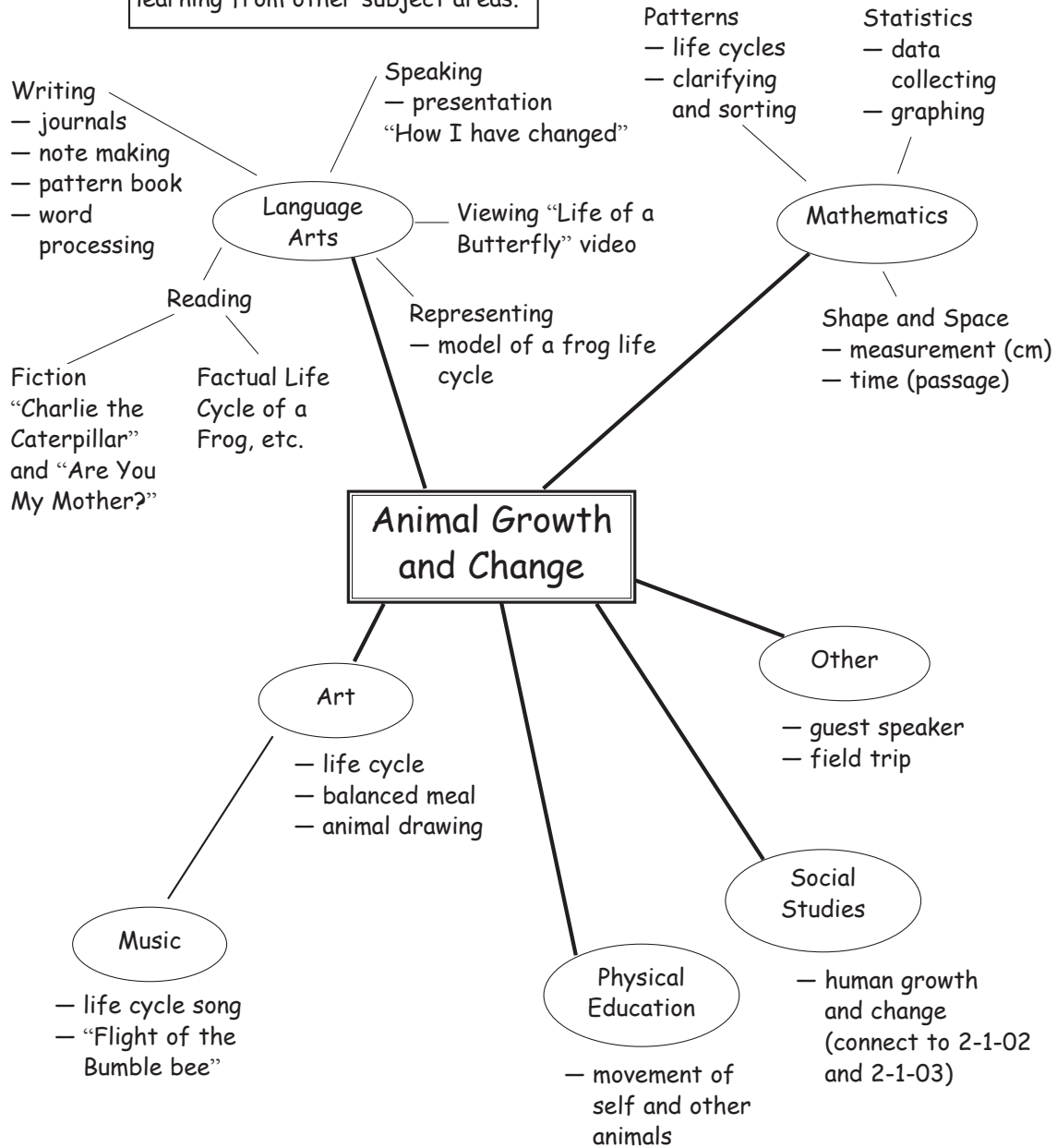

Planning Instructional Units

Kindergarten to Grade 4 Science: Manitoba Curriculum Framework of Outcomes (1999) prescribes general and specific student learning outcomes for Early Years students in Manitoba. The specific student learning outcomes identify what all students are expected to know and be able to do by the end of each grade.

As noted in *Senior 2 English Language Arts: A Foundation For Implementation* (1998) (hereafter referred to as *S2 ELA*), teachers play an enormous role in facilitating student growth. They determine the organization, pace, and focus of instruction. Effective teachers keep instruction centred on student learning outcomes and maintain high expectations for instruction and assessment. They differentiate instruction and provide developmentally appropriate learning experiences and opportunities for all students to achieve the learning outcomes.

Creating balanced, integrated science programming is an individual and creative process. Many elements shape Early Years science programming including:

- the teaching style, resources, and strengths of each teacher
- the interests, ideas, and gifts students brings to the classroom
- the learning requirements of individual students
- the community, public events, and resources that provide science learning opportunities

Teachers need to recognize that there are many factors that have an influence on the direction and character of student learning and achievement. The following discussion adapted from *S2 ELA* suggests a number of points for consideration for teachers as they plan their units. These considerations are also relevant to Early Years science teachers.

Learning outcomes are generally not taught separately or in isolation from each other. Almost all classroom learning experiences involve several learning outcomes. Focussing on the learning outcomes that they plan to assess, rather than all the learning outcomes involved in a learning experience, may help teachers to plan.

Learning is recursive, and many of the learning outcomes need to be addressed repeatedly in different ways throughout the school year. As well as developing new scientific and technological skills, students need to practise and refine those learned previously.

General and specific learning outcomes are end-of-the year outcomes for students. Teachers need to consider and plan for the series of instructional steps that will assist students in achieving all the prescribed learning outcomes by the end of the school year.

Planning is ongoing throughout the year, informed by student interests and learning requirements that become evident through classroom assessment. (p. 3)

Planning Tools

To assist in planning for the implementation of the Kindergarten to Grade 4 science learning outcomes, several tools have been included in *Kindergarten to Grade 4 Science: A Foundation for Implementation*. Planning supports for Kindergarten to Grade 4 science include:

- ledger-size, **Grade-at-a Glance Charts** (Clusters 1—3 or 1—4), one for each grade, each of which lists student learning outcomes
- a three-page, **Overall Skills and Attitudes Chart** (Cluster 0), that provides an overview of student learning outcomes for all grades
- **Guidelines for Planning** that show a suggested sequence of steps for planning an instructional unit
- a **Planning Think-Aloud** that demonstrates the steps taken by a group of teachers as they create a sample science unit on plants
- an online, searchable database available on the Manitoba Education and Training website located at
< <http://www.edu.gov.mb.ca/metks4/curricul/k-s4curr/science/index/html> >

Teachers should utilize the methods and supports that best suit their planning styles. Manitoba Education and Training's online workspace enables teachers to individualize their planning by electronically arranging student learning outcomes, and adding their own comments as they create their teaching units. The Grade-at-a Glance and the Overall Skills and Attitudes Charts will enable teachers to view the broad scope of student learning outcomes for each grade. These pull-out charts provide an excellent starting point for the planning of instructional units. The Guidelines for Planning and Planning Think-Aloud that follow are intended as suggestions only.

Guidelines for Planning

Review the Grade-at-a-Glance and Overall Skills and Attitudes charts to become familiar with the student learning outcomes and related skills and attitudes for a particular grade or grade grouping

Identify learning outcomes that logically fit together and could be used as a focus for study to meet students' learning requirements for that grade

Develop a mind-map to show the relationship among the outcomes by identifying concepts and sub-concepts and an overall order in which they can be addressed

Complete a science planning sheet, such as the one below

- list the student learning outcomes in the order that they will be addressed
- identify assessment strategies and tools to match the student learning outcomes (begin by considering those included in the Suggestions for Assessment column)
- list the associated learning experiences provided in the Suggestions for Instruction (add or delete as needed)
- identify skills and attitudes (Cluster 0) to be addressed
- build in links to other subject areas
- identify supplies, materials, and learning resources, (including literature) to support the learning experiences

Skills	Student Learning Outcomes	Learning Experiences	Assessment	Subject Links	Supplies/Materials	Resources/Literature

Address and accommodate the variety of student needs and learning styles by considering

- differentiated instruction and developmental appropriateness
- multi-modal learning experiences that allow all students to use their strengths
- cooperative or collaborative strategies, grouping patterns, and social skills
- critical and creative thinking and metacognitive strategies
- multiple intelligences
- cultural inclusiveness

Plan with the Student Learning Outcomes in Mind!

Planning Think-Aloud

Grade 3: Plants

The following sample is intended to illustrate how the Guidelines for Planning may be used.

Review

As a team, we reviewed the Grade-at-a-Glance and Overall Skills and Attitudes charts to become familiar with the science knowledge, skills, and attitudes that students are expected to acquire and demonstrate by the end of Grade 3.

Identify

We decided to begin the year with a focus on plants. This decision was based on several factors: in September live plants are easily observable, composting can take place, and students are likely to bring to the class prior knowledge of plant growth and changes. We also determined that an understanding of the relationship between soil types and growth of plants was important. For these reasons we decided that our first instructional unit would address all of the outcomes from Cluster 1: Growth and Changes in Plants, as well as several from Cluster 4: Soils in the Environment.

Develop

Once we had determined the learning outcomes we wished to address, we developed a mind-map to identify the concepts and sub-concepts that we would address through the learning outcomes. We made sure that all of the learning outcomes we wanted to cover were included on the mind-map.

Once the mind map was completed, we determined an overall order for how we wanted to approach the unit. This is identified in the Sequence of Topics. The first things we decided were how to begin and end the unit. We knew that the beginning of a new unit should be interesting to the students, motivating them to want to learn more about the topic. We identified composting as a good place to start, realizing that the soil produced could be used as a growing medium later in the unit. We chose the design process project as the culminating learning experience. This project provides students the opportunity to apply the things they learned throughout the unit in a practical, hands-on manner.

Sample Mind-Map for Plants

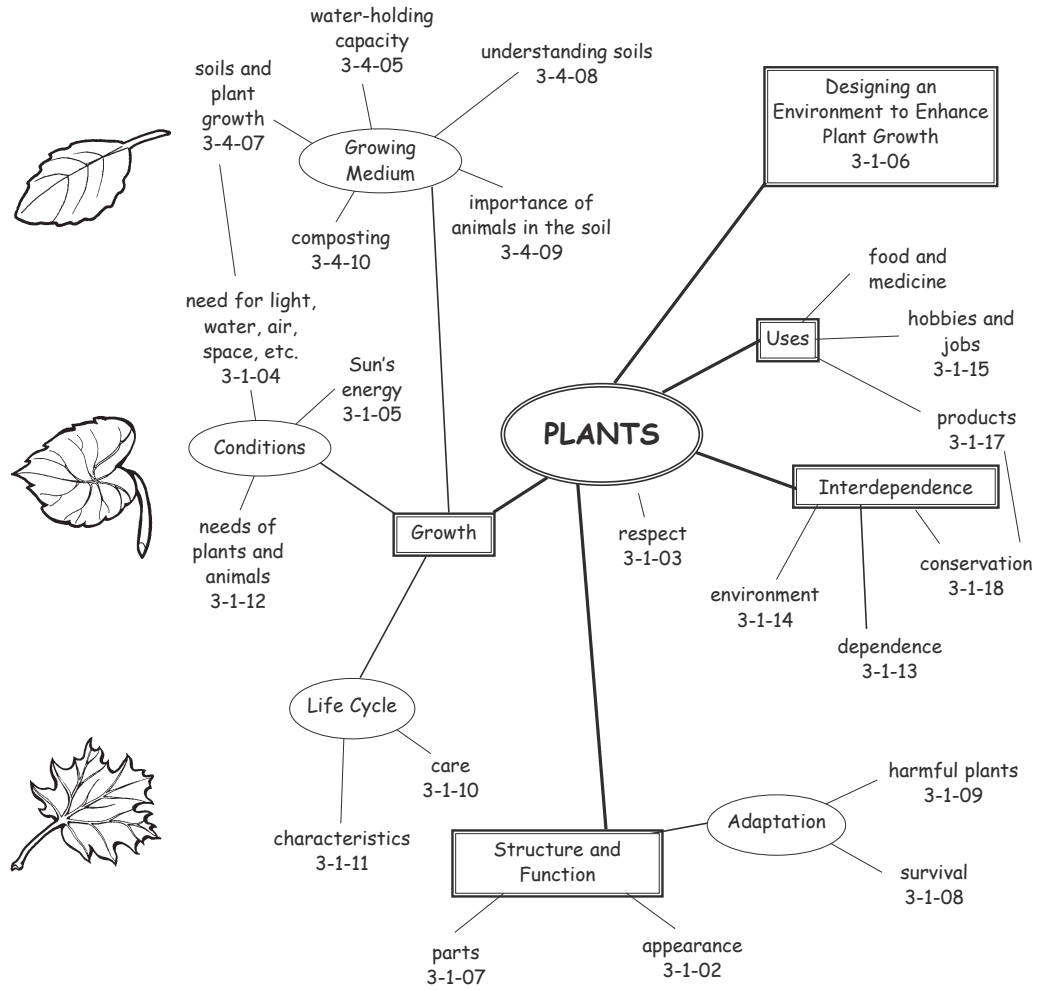

Sequence of Topics

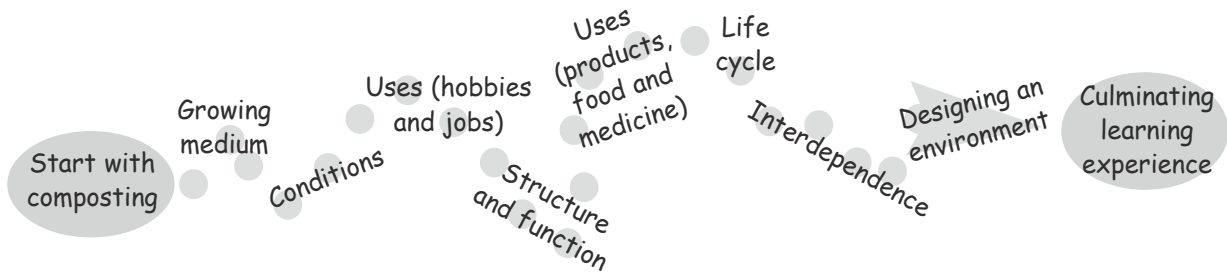

Complete

Our next step was to complete a science planning sheet. We listed all of the specific learning outcomes in the order we wished to address them in the unit on plants. We retained the headings from our mind-map to help remind us of the major concepts. We consulted *Kindergarten to Grade 4 Science: A Foundation for Implementation* for ideas on how to assess student attainment of the learning outcomes, and suggested learning experiences that would help students achieve the outcomes. We also selected outcomes from Cluster 0: Overall Skills and Attitudes that could be addressed by these learning experiences. We left out learning experiences and strategies that did not fit with our approach to the unit and our students' needs and added in others. We verified that Cluster 0 learning outcomes were reflected in the experiences chosen. Finally, we made note of links to other subject areas and identified supplies/materials, and learning resources.

Address

After these initial planning steps, we reviewed our unit on plants to ensure that it would enable all of our students to achieve the prescribed learning outcomes. We considered:

- differentiated instruction and developmental appropriateness
- multi-modal learning experiences
- critical and creative thinking and metacognitive strategies
- multiple intelligences
- cultural inclusiveness

For example, we noted that we had included a variety of instructional approaches and activities, e.g., hands-on experiences, research, and real-life tasks. Students would therefore be able to represent what they learned in a variety of ways. What was missing from this section was the opportunity to identify prior knowledge. Students bring a great deal of knowledge as well as some misconceptions to the class. We knew it would be important to identify entry-level knowledge in order to plan for instruction. Students learn best when they can relate new knowledge to what they already know. We did not want our students to build on misconceptions. Additionally, our school also has many students from other countries and cultures, providing an opportunity to include non-local varieties of plants, where appropriate, within the instructional unit.

Science Planning Sheet — Grade 3: Plants

Skills	Student Learning Outcomes	Learning Experiences	Assessment	Subject Links	Supplies/ Materials	Learning Resources
3-0-6c (classifying)	Structure and Function 3-1-02 Observe, compare, and contrast the structure and appearance of several types of plants.	Page 3.2 Compare and Contrast Venn Comparison	Observation Checklist for Self-Assessment (p. 3.3)	Math PR-I.1.3 Art (p. 3.2)	Plant samples for centre, plant press for art cards, heavy paper	
3-0-2a (access information) 3-0-2b (review information)	3-1-07 Identify the basic parts of plants and describe their functions. Include: roots, stems, leaves, flowers, pistil, stamen, ovule, pollen, seeds, fruit.	Page 3.8 Plant Observations Plant Discovery: Stems Carry Nutrients, Leaves Give Off Oxygen Flower Power	Paper-and-Pencil Task: Plant Observations (p. 3.9)	ELA 1.1.2, 3.2.2 Math SP-I-1.2.3 TFS 2.1.1.	plant samples with all parts, plastic cups, food colouring, celery, flash-light	Plant parts CD-ROM, software package, "The Reason for a Flower" storybook
3-0-4a (carry out a plan) 3-0-5e (record observations)	3-1-08 Explain how different adaptations of plants help them survive in particular environments. 3-1-09 Identify plant adaptations that can be harmful to humans, and describe their effects.	Page 3.8 Weed Pull Plant Adaptation Research		Math SP-V.2.3, SP-II.2.1, SP-II.2.1 ELA 3.2.1, 3.3.2, 4.1.3;	Identify area to have students weed.	<i>Discover Agriculture Science Curriculum Activities</i> on plant adaptations.

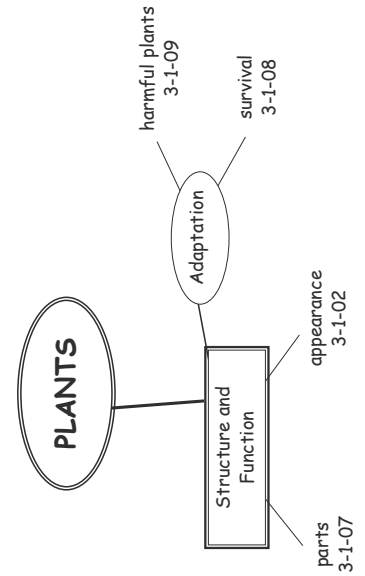

DOCUMENT ORGANIZATION

The Four Column Format

Prescribed learning outcome statements that define what students are expected to achieve at the end of each grade

Suggestions for student learning experiences directly related to the attainment of specific learning outcomes

Kindergarten to Grade 4 Science: A Foundation for Implementation

PRESCRIBED LEARNING OUTCOMES	SUGGESTIONS FOR INSTRUCTION
<p><i>Students will...</i></p> <p>3-1-01 Use appropriate vocabulary related to their investigations of growth and changes in plants. Include: growing medium, nutrient, energy, root, stem, leaf, flowers, pistil, stamen, ovule, pollen, seed, fruit, adaptation, life cycle. GLO: C6, D1</p>	<ul style="list-style-type: none"> ➤ Introduce, explain, use, and reinforce vocabulary throughout this cluster. ➤ Word Cycle Teach students how to use a word cycle to help them become familiar with the specific vocabulary related to the learning outcomes in this cluster. Use the word cycle to assess students' knowledge of terms studied in specific sections of this cluster (see <i>Success for All Learners</i>, 6.31).
<p>3-1-02 Observe, compare, and contrast the structure and appearance of several types of plants. <i>Examples: plants with different types of roots, trees with needles and trees with leaves...</i> GLO: C2, D1, E1</p> <p>3-1-03 Show respect for plants as living things. GLO: B5</p>	<ul style="list-style-type: none"> ➤ Plant Etiquette Discuss and develop a list of guidelines and safety procedures to follow to ensure students show respect for plants as living things. Guidelines might include: avoid trampling on plants, touch plants only after an adult has given permission, touch and bend the plant gently to avoid damage, observe using sense of sight and sense of smell before using sense of touch, etc. ➤ Compare and Contrast Set up a plant observation centre where students sort and classify plants. Have students explain the method used and then resort and relabel the groups. Plants should be provided that show a variety of roots, leaves, flowers, and seeds.
<p>3-0-4h. Follow given safety procedures and rules, and explain why they are needed. GLO: C1</p> <p>3-0-5a. Make observations that are relevant to a specific question. GLO: A1, A2, C2</p> <p>3-0-5b. Use tools to observe, measure, and construct. Include: ruler, metre stick, pan balance, magnifying glass, bathroom scale, thermometer, magnet. (Math SS-I.1.3, SS-III.1.3, SS-IV.1.3, SS-VII.4.3) GLO: C2, C3, C5</p> <p>3-0-6c. Place materials and objects in a sequence or in groups using two or more attributes, and describe the system used. (Math PR-I.1.3) GLO: C2, C3, C5</p>	<ul style="list-style-type: none"> ➤ Venn Comparison: Plants In small groups, have students select two plants to compare and contrast using a Venn diagram. Students may prefer to draw the parts of each plant to show the differences. <div style="text-align: center; border: 1px solid black; padding: 10px; margin: 10px 0;"> </div> <ul style="list-style-type: none"> ➤ Art Connection Have students sketch a plant and/or press a plant to make an environmental note card.

Learning outcomes related to thematic clusters

Learning outcomes related to Cluster O, Overall Skills and Attitudes, selected to correspond to Suggestions for Instruction

Background information and/or definitions for teachers, often beyond what students are required to know; safety information

Suggestions for assessing specific learning outcome(s)

Grade 3, Cluster 1: Growth and Changes in Plants

TEACHER NOTES

SUGGESTIONS FOR ASSESSMENT

Cluster Note: Students' achievement of the learning outcomes in this cluster is dependent on having adequate time to conduct experiments on plant growth and to follow a flowering plant through a complete life cycle.

Caution: Ensure that there are no dangerous plants such as poison ivy or poison berries in your local area. Check to make sure that there are no students with plant allergies in your class. (Refer to *Success for All Learners*, 9.5 for details on conducting an ecology walk.)

Have a plant collection already prepared to ensure a wide variety. Students could participate in making plant collections. Alternatives to live plant collections include pictures of plants or examples of live houseplants.

When discussing the Venn diagram introduce the related vocabulary.

Science Journal Entry: Plant Etiquette

Directions to students: In your science journals, finish the following sentence:

I can show respect for plants as living things by _____.

List as many examples as you can.

Look for

- examples related to avoiding damage to plants
- references to safety issues

Observation Checklist for Student Self-Assessment

Directions to students: At the plant observation centre you will be comparing plants to determine how they are the same and how they are different. Use this checklist to check your observation skills.

How Are My Observation Skills?

I used the following senses to observe:

sight smell touch hearing

I used the following tools:

- magnifying glass
- centimetre ruler
- other _____

I observed the following properties:

colour shape texture size

I also observed _____

Caution: Indicates an important consideration for planning around safety issues

Grey line indicates the start of a new grouping of prescribed learning outcomes and associated suggestions for instruction, teacher notes, and suggestions for assessment. Included only when more than one grouping appears on a page

3.3

Guide to Reading Specific Learning Outcomes

PRESCRIBED LEARNING OUTCOMES	SUGGESTIONS FOR INSTRUCTION
<p><i>Students will...</i></p> <p>3-1-01 Use appropriate vocabulary related to their investigations of growth and changes in plants. Include: growing medium, nutrient, energy, root, stem, leaf, flowers, pistil, stamen, ovule, pollen, seed, fruit, adaptation, life cycle. GLO: C6, D1</p>	<p>➤ Introduce, explain, use, and reinforce vocabulary throughout this cluster.</p> <p>Word Cycle Teach students how to use a word cycle to help them become familiar with the specific vocabulary related to the learning outcomes in this cluster. Use the word cycle to assess students' knowledge of terms studied in specific sections of this cluster (see <i>Success for All Learners</i>, 6.31).</p>
<p>3-1-02 Observe, compare, and contrast the structure and appearance of several types of plants. Examples: <i>plants with different types of roots, trees with needles and trees with leaves...</i> GLO: C2, D1, E1</p>	<p>➤ Plant Etiquette Discuss and develop a list of guidelines and safety procedures to follow to ensure students show respect for plants as living things. Guidelines might include: avoid trampling on plants, touch plants only after an adult has given permission, touch and bend the plant gently to avoid damage, observe using sense of sight and sense of smell before using sense of touch, etc.</p>
<p>3-1-03 Show respect for plants as living things. GLO: B5</p>	<p>➤ Compare and Contrast Set up a plant observation centre where students sort and classify plants. Have students explain the method used and then resort and relabel the groups. Plants should be provided to show a variety of roots, leaves, flowers, and seeds.</p>
<p>3-0-4h. Follow given safety procedures and rules, and explain why they are needed. GLO: C1 3-0-5a. Make observations that are relevant to a specific question. GLO: A1, A2, C2 3-0-5b. Use tools to observe, measure, and construct. Include: ruler, metre stick, pan balance, magnifying glass, bathroom scale, thermometer, magnet. (Math SS-I.1.3, SS-III.1.3, SS-IV.1.3, SS-VII.4.3) GLO: C2, C3, C5 3-0-6c. Place materials and objects in a sequence or in groups using two or more attributes, and describe the system used. (Math PR-I.1.3) GLO: C2, C3, C5</p>	<p>➤ Venn Comparison: Plants In small groups, have students select two plants to compare and contrast using a Venn diagram. Students should show the parts of each plant to show the difference.</p>

PRESCRIBED LEARNING OUTCOMES

Students will...

3-1-01 Use appropriate vocabulary related to their investigations of growth and changes in plants.
 Include: growing medium, nutrient, energy, root, stem, leaf, flowers, pistil, stamen, ovule, pollen, seed, fruit, adaptation, life cycle.
 GLO: C6, D1

3-1-02 Observe, compare, and contrast the structure and appearance of several types of plants.
Examples: plants with different types of roots, trees with needles and trees with leaves...
 GLO: C2, D1, E1

3-1-03 Show respect for plants as living things.
 GLO: B5

3-0-4h. Follow given safety procedures and rules, and explain why they are needed. GLO: C1
3-0-5a. Make observations that are relevant to a specific question. GLO: A1, A2, C2
3-0-5b. Use tools to observe, measure, and construct. Include: ruler, metre stick, pan balance, magnifying glass, bathroom scale, thermometer, magnet. (Math SS-I.1.3, SS-III.1.3, SS-IV.1.3, SS-VII.4.3) GLO: C2, C3, C5
3-0-6c. Place materials and objects in a sequence or in groups using two or more attributes, and describe the system used. (Math PR-I.1.3) GLO: C2, C3, C5

First digit indicates grade; second digit indicates cluster number; third digit(s) indicates specific learning outcome number

Include: Indicates a mandatory component of the specific learning outcome

Cross-reference to general learning outcomes (See Appendix A)

Example: Provides ideas of what could be included (non-mandatory)

Cross-reference to other areas: Math, ELA (English Language Arts), TFS (Technology as a Foundation Skill Area)

Kindergarten Science

Kindergarten

Cluster 1: Trees

Overview

In Kindergarten, an investigation of trees capitalizes on students' curiosity about the world around them. Students' observations of trees, including their seasonal changes, are complemented by a study of basic parts and uses of trees.

PRESCRIBED LEARNING OUTCOMES	SUGGESTIONS FOR INSTRUCTION
<p><i>Students will...</i></p>	
<p>K-1-01 Use appropriate vocabulary related to their investigations of trees. Include: tree, trunk, crown, branch, leaf, needle, bark, root, seed, winter, spring, fall, summer. GLO: C5, D1, D5</p>	<ul style="list-style-type: none"> ➤ Introduce, explain, use, and reinforce vocabulary throughout this cluster. ➤ Picture Word Chart Chart vocabulary words for this cluster. Beside each word, and include a picture that helps to identify it. Have students work in pairs. One student points to the picture. The second student points to the word and identifies what it says. (Post the chart and encourage students to refer to the chart during free play or centre activities.)
<p>K-1-02 Identify ways in which humans and other animals use trees. <i>Examples: humans eat apples and walnuts; birds make their homes in trees; deer eat leaves, bark, and tender twigs...</i> GLO: B1</p> <p>K-1-03 Identify and describe basic parts of a tree. Include: trunk, crown, branch, leaf, bark, root, seed. GLO: D1, E2</p>	<ul style="list-style-type: none"> ➤ Observing the Environment As a class, take a walk in the schoolyard or surrounding neighbourhood. Have the students ask questions about and observe several different types of trees. Point out the basic parts of the tree. Have students draw or paint a picture of a tree that they saw on their walk. Encourage students to include many details. Collect fallen leaves of different colours from a variety of trees to be used later in K-1-04 Leaf Sort. ➤ Tree Centre: Tree Uses Prior to visiting the Tree Centre, have students ask people in the school and family members at home about ways that humans and other animals use trees. At the Tree Centre have objects (both natural and human-made) that come from trees for students to explore. Have students search through magazines to find pictures to show how both animals and people use trees, and work in small groups to use these pictures to make a collage.
<p>K-0-1a. Ask questions that demonstrate a curiosity about living things, objects, and events in the immediate environment. (ELA 1.2.4, 3.1.2, 3.1.3) GLO: A1, C2, C5</p> <p>K-0-2a. Seek information from others. <i>Examples: people at school, at home, in the community...</i> (ELA 3.2.2, 3.2.4; Math SP-II.1.0) GLO: C6</p> <p>K-0-3c. Select materials to be used. GLO: C2, C3</p> <p>K-0-4e. Participate in cooperative group learning experiences. (ELA 5.2.1) GLO: C7</p> <p>K-0-5c. Record observations using drawings. (ELA 4.1.2, 4.2.5) GLO: C6</p> <p>K-0-7b. Describe, in a variety of ways, what was done and what was observed. <i>Examples: concrete materials, drawings, oral language....</i> (ELA 4.1.2, 4.1.3) GLO: C6</p> <p>K-0-9a. Be open-minded while exploring. GLO: C5</p>	

(continued)

TEACHER NOTES

SUGGESTIONS FOR ASSESSMENT

Cluster Note: This cluster should be an ongoing theme throughout the year as students observe trees through the seasons. Some learning experiences are more appropriate to one particular season; others should be repeated in different seasons.

Emphasize the number and variety of trees that can be seen, while drawing students' attention to the common parts.

The **crown** is the top of the tree (branches, leaves, etc.).

Bring items made from trees into the classroom for students to examine.

Checklist: Observing the Environment

To provide formative data, use a checklist to assess students' drawings related to tree observations. Example:

The drawing includes

- trunk
- leaves/needles
- branches
- roots
- realistic colours
- other (nests, seeds, cones, insects, etc.)

PRESCRIBED LEARNING OUTCOMES	SUGGESTIONS FOR INSTRUCTION
<p><i>Students will...</i></p>	<p>➤ “Build a Tree” Role Play</p> <p>Have students role play the parts of a tree. Ask them to lie on the floor and build the tree from the roots to the crown. Make signs for each part of the tree, including a picture and the word for each part. Depending on the number of people in the class, there could be four roots, three trunks, six branches, eight leaves, and three acorns. As the students build the tree, use the following questions to guide them:</p> <ul style="list-style-type: none"> • What holds the tree in the ground and gives it food and water? • What part of the tree helps it stand tall and is covered with bark? • In which parts of the tree do birds build their nests? • What part of the tree gets food from the sun and gives the tree its colour? • From which part of the tree will another tree grow? <p>➤ Sketch and Label Tree Parts</p> <p>Have the students draw a picture of a tree. Post the signs used in the Role Play activity and ask students to label the parts of the tree on their drawing.</p>
<p>K-1-04 Explore, sort, and classify leaves, using their own classification system.</p> <p><i>Examples: size, colour, pattern, length, shape...</i></p> <p>GLO: C2, D1, E1</p>	<p>➤ Looking at Leaves</p> <p>Have the students observe the leaves they have collected. Have students record their observations on a class chart in response to the following questions:</p> <ul style="list-style-type: none"> • What colours and shapes do you see? • How do the leaves feel? • What size are the leaves? • What patterns do you see?
<p>K-0-4e. Participate in cooperative group learning experiences. (ELA 5.2.1) GLO: C7</p> <p>K-0-5a. Observe using one or a combination of senses. GLO: C2</p> <p>K-0-5c. Record observations using drawings. (ELA 4.1.2, 4.2.5) GLO: C6</p> <p>K-0-6c. Place materials and objects in a sequence or in groups using a single, self-determined attribute. (Math PR-I.1.0) GLO: C2, C3, C5</p>	<p>➤ Leaf Sort</p> <p>Have the students work in groups to sort the leaves according to one attribute and then have them share their sorting rules. Have the groups re-sort their leaves according to a different rule.</p> <p>➤ Guess My Rule</p> <p>As a class, play the game “Guess My Rule.” A student sorts the leaves, asks: “What’s my rule?” and selects someone to answer. The student who guesses correctly becomes the leader and sorts the leaves another way. The game continues until the group runs out of sorting attributes.</p> <p>➤ Art Connection</p> <p>At the Art Centre, have the students do leaf rubbings to observe the patterns made by the leaves.</p>

TEACHER NOTES

SUGGESTIONS FOR ASSESSMENT

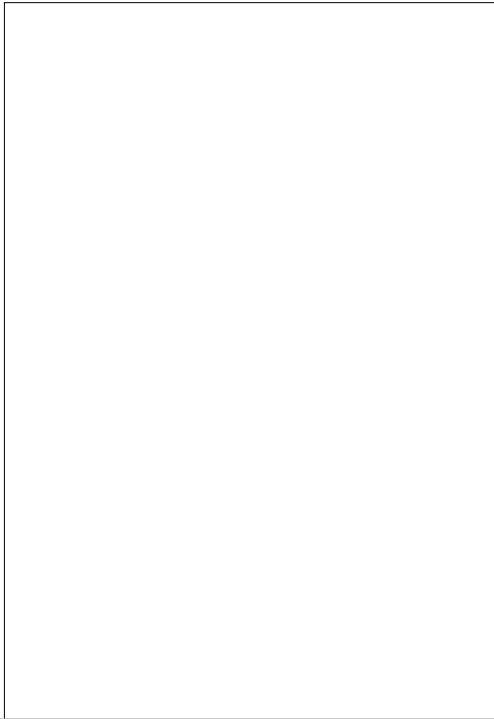

Paper and Pencil Task: Parts of the Tree

To determine student understanding of the parts of a tree and the related vocabulary, give each student a picture of a deciduous tree. Give the following oral instructions:

- Colour the trunk brown.
- Colour two leaves green.
- Colour one branch orange.
- Colour the roots red.
- Colour the crown brown.

If you laminate the leaves, they will keep their colour and will not dry and crumble. Laminated leaves can be kept for many years.

Performance Task: Leaf Sort

Work with individuals or small groups. Give each student a selection of leaves. Have the student sort the leaves in one way and then tell the sorting rule. Have the student re-sort the leaves in another way and give the rule.

Scoring Rubric

- 4 The student is able to sort the leaves in more than one way. The sorting rules are clearly and accurately communicated.
- 3 The student is able to sort the leaves in more than one way. The sorting rules are evident but not clearly communicated.
- 2 The student is able to sort the leaves in one way. The sorting rule is clearly and accurately communicated.
- 1 The student is able to sort the leaves in one way. The student has difficulty communicating the sorting rule.

PRESCRIBED LEARNING OUTCOMES
<i>Students will...</i>
<p>K-1-05 Name and describe each of the four seasons. GLO: D6</p> <p>K-1-06 Recognize that some trees lose their leaves in the fall, while others do not. GLO: D1</p> <p>K-1-07 Describe seasonal changes in the life of a tree. <i>Examples: leaves of some trees change colour and drop off in the fall...</i> GLO: D1</p>
<p>K-0-1b. Make predictions as to what might happen during explorations. (ELA 1.2.1) GLO: A1, C2</p> <p>K-0-2b. Compare gathered ideas and information to personal knowledge. (ELA 3.2.3, 3.3.3; Math SP-IV.1.0) GLO: C6, C8</p> <p>K-0-4f. Verbalize questions during classroom learning experiences. GLO: C6</p> <p>K-0-7a. Recognize connections between new experiences and prior knowledge. (ELA 1.2.1) GLO: A2</p> <p>K-0-7b. Describe, in a variety of ways, what was done and what was observed. <i>Examples: concrete materials, drawings, oral language...</i> (ELA 4.1.2, 4.1.3) GLO: C6</p>

SUGGESTIONS FOR INSTRUCTION

➤ **Identifying the Four Seasons**

As a class, brainstorm and list the four seasons. Discuss what a crabapple (or other common) tree might look like through the four seasons.

➤ **Comparing Trees**

Have students view through pictures, in person, or using multimedia, a deciduous tree and a coniferous tree.

As a class, make comparisons between the two, including what happens to each in the fall, on a chart similar to the following:

Oak	Spruce
has leaves	has needles
has acorns	has pinecones
leaves fall off	needles are always there

➤ **Adopt a Tree**

At the start of the school year, have the students “adopt” a tree. Have the class make predictions as to how the tree will change during the different seasons, and then have them observe the tree over the course of the school year.

Each season, have the students observe and record the appearance of the tree through drawings and words. The drawings could be part of a student-made booklet that is kept over the course of the year. Ask these questions each time the students make their observations:

- Are there any leaves on the tree? If so, what size and colour are they?
- Are there any fruit or nuts, buds or flowers growing on the tree?
- Are there any animals living in or on the tree?

TEACHER NOTES

SUGGESTIONS FOR ASSESSMENT

It would be beneficial to adopt two different trees if possible, one deciduous and one coniferous. This would allow students to see the similarities and differences between them.

Interview: The Four Seasons

For this assessment task gather the following materials:

- a set of pictures (no more than eight) that shows children, plants, and animals at different seasons of the year. Example: child(ren) building a snowman, child(ren) at the beach, bear(s) hibernating, bird(s) feeding babies, squirrel(s) gathering nuts, etc.
- a picture of a deciduous tree in each of the four seasons
- pictures of a deciduous tree with leaves and a coniferous tree with needles

Observe individual students as they perform the tasks and record their responses.

1. Can you name the four seasons? Check those given.

- Spring Summer Fall Winter

2. Here is a set of pictures. These pictures show people, plants, and animals doing different things. Can you find a picture that shows something that might happen in

- Spring? Summer? Fall? Winter?

Notes: _____

3. Show the four pictures of the deciduous tree. Some trees look different in each season. Can you show the tree in

- Spring? Summer? Fall? Winter?

If you put the pictures in order from spring to winter, what picture would come first? Next?

Notes: _____

4. Can you tell me something about each of the pictures?

(Does the student accurately describe the changes for each season?) _____

PRESCRIBED LEARNING OUTCOMES
<i>Students will...</i>
<p>K-1-08 Investigate to determine that many trees produce seeds which are dispersed and may grow into new trees. GLO: C2, D1</p>
<p>K-0-1a. Ask questions that demonstrate a curiosity about living things, objects, and events in the immediate environment. (ELA 1.2.4, 3.1.2, 3.1.3) GLO: A1, C2, C5 K-0-4g. Follow given safety procedures and rules. (ELA 2.1.2) GLO: C1 K-0-5c. Record observations using drawings. (ELA 4.1.2, 4.2.5) GLO: C6 K-0-8a. Recognize that learning can come from careful observations and investigations. (ELA 3.3.4) GLO: A1, A2, C2 K-0-9b. Willingly observe, question, and explore. GLO: C5 K-0-9c. Express enjoyment of science-related classroom activities. GLO: C5</p>

SUGGESTIONS FOR INSTRUCTION

➤ **Seeds from Trees**

During the spring, have the students collect seeds from trees. This could be a “home” assignment. The collection will need to be supplemented to provide a wide variety of examples such as helicopter seeds (maple), acorns, pinecones, and fluff from cottonwood trees.

Have students examine the seeds with a hand lens to observe similarities and differences. Use the following questions to focus discussion:

- What does the seed look like?
- Do you see anything on the seed that might help it move from place to place?
- What is the purpose of the seed?

Plant a seed and water it until it sprouts.

➤ **Matching Tree and Seed**

Using card stock, glue several seeds onto one half of a card, and a picture of the tree from which the seed comes on the other half. Cut the card like a puzzle piece, and place the pieces in a learning centre. Repeat with different kinds of seeds and trees. Have students match the seed to the tree.

➤ **Science Stories and Songs**

Create a group story, song, or rhyme telling about the life of a tree as it grows from seed to maturity, and throughout the seasons.

TEACHER NOTES

SUGGESTIONS FOR ASSESSMENT

It may be difficult for students to distinguish between seeds from trees and seeds from other plants. Encourage them to look for seeds on the ground and then look up to find the same seeds on the tree.

Observation Checklist: Seeds from Trees

Throughout the investigation of seeds, observe and note evidence of the following skill- and attitude-related behaviours:

The student

- willingly observes, questions, and explores
- expresses enjoyment of the learning experiences
- records observations using drawings
- uses the hand lenses safely and purposefully
- asks questions related to seeds and trees

NOTES

Kindergarten

Cluster 2: Colours

Overview

Colour is an important part of the world around us. Through observations and the use of specific vocabulary, students develop their ability to describe their world in terms of colour. They also explore how to create colours by mixing them and where colours are found in the environment.

PRESCRIBED LEARNING OUTCOMES	SUGGESTIONS FOR INSTRUCTION
<p><i>Students will...</i></p>	
<p>K-2-01 Use appropriate vocabulary related to their investigations of colours.</p> <p>Include: red, yellow, blue, orange, brown, black, white, purple, green, grey, pink, mix, light, dark, match, primary colour.</p> <p>GLO: C6, D3</p>	<ul style="list-style-type: none"> ➤ Introduce, explain, use, and reinforce vocabulary throughout this cluster. Students need to learn to identify and name different colours. This understanding can be developed in tasks within art, mathematics, language arts, social studies, and science throughout the Kindergarten year. Look for situations in which students’ conversations, questions, and responses demonstrate readiness for the introduction of a specific term. New vocabulary will enable them to talk about colour in a more succinct and precise manner. Use the new term(s) in your conversations with them. ➤ Colour Word Wall Display colour words along with appropriately coloured symbols where they are easily visible. Add each colour word when that colour becomes the focus as in Colour of the Day/Week.
<p>K-2-02 Sort and classify objects by colour.</p> <p>GLO: C2, D3</p>	<ul style="list-style-type: none"> ➤ Colour of the Day/Week Introduce colours by featuring a colour for each day/week. Use that colour for routine classroom activities such as recording attendance, making name tags, and organizing centre activities. Have students wear items of clothing that match the colour of the day/week.
<p>K-0-3c. Select materials to be used. GLO: C2, C3</p> <p>K-0-6a. Construct, with guidance, concrete-object graphs using 1:1 correspondence. (Math SP-III.2.0) GLO: C2, C6</p> <p>K-0-6b. Compare data using appropriate terms. <i>Examples: more, less, same...</i> (Math SP-IV.1.0) GLO: A1, A2, C2, C5</p> <p>K-0-6c. Place materials and objects in a sequence or in groups using a single, self-determined attribute. (Math PR-I.1.0) GLO: C2, C3, C5</p> <p>K-0-7b. Describe, in a variety of ways, what was done and what was observed. <i>Examples: concrete materials, drawings, oral language....</i> (ELA 4.1.2, 4.1.3) GLO: C6</p>	<ul style="list-style-type: none"> ➤ Colour Treasure Hunt Have the students find something in the room that is coloured red, blue, yellow, etc. Have them share their discoveries with the class and then use the items to make a concrete graph. Have students compare the data on their graphs using appropriate terms. ➤ Sort and Classify By Colour (Centre) At the Math Centre, provide a variety of materials that can be classified and sorted according to colour. Examples: unifix/interlocking cubes, beads, buttons, etc. Have students sort a material of their choice or a combination of different materials according to colour, and record what they have done through drawings.
	<ul style="list-style-type: none"> ➤ Colour Collage Have students work in small groups to create a one-colour collage using a variety of materials/tools. Examples: magazine pictures, wallpaper samples, cloth, wool, crayons, markers, paint, etc.

(continued)

TEACHER NOTES

SUGGESTIONS FOR ASSESSMENT

Note: Commercially made materials often have consistency of colour, necessary for Early Years sorting tasks. Sorting tasks are made more difficult when attributes are not easily recognized and identifiable.

Materials used for sorting should be in solid colours. Avoid multi-coloured buttons, beads, etc. Craft buttons come in solid colours.

Interview: Sort and Classify by Colour

Before the interview gather a set of commercially made materials such as interlocking cubes or craft buttons.

1. Show the student different cubes and have him/her orally identify the colours.

<input type="checkbox"/> red	<input type="checkbox"/> green
<input type="checkbox"/> orange	<input type="checkbox"/> blue
<input type="checkbox"/> yellow	<input type="checkbox"/> black
<input type="checkbox"/> brown	<input type="checkbox"/> purple

2. Show the student the unifix cubes, etc. Ask the students to sort the cubes by colours.
 - student sorted correctly
 - student was able to name/label the sorted groups

3. Give the student a small collection of craft buttons or cubes and a labelled pictograph. Have the student place the materials on the graph.
 - student sorted correctly on the pictograph
 - student was able to tell how many of each colour were on the graph
 - student was able to indicate which was more, less, the same

PRESCRIBED LEARNING OUTCOMES
<i>Students will...</i>

SUGGESTIONS FOR INSTRUCTION

- **Colour Surveys**
At the Math Centre, have the students
 - survey classmates to determine favourite colours
 - tally and graph the colours that classmates wear
 - compare the data using terms such as more, less, and same
- **Writing Centre**
Have the class make a big alphabet book. Have each student select a letter of the alphabet and choose an object to represent that letter. Students must draw, label, and colour their object accordingly. Example:

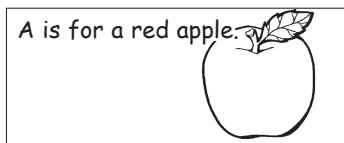

<p>K-2-03 Compare and contrast colours using appropriate terms. <i>Examples: lighter than, darker than, brighter than...</i> GLO: C2, D3</p>
<p>K-2-04 Order a group of objects based on a given colour criterion. <i>Examples: order objects of the same colour range from lightest to darkest...</i> GLO: C2, D3</p>
<p>K-0-4a. Manipulate materials purposefully. GLO: C1, C2 K-0-6c. Place materials and objects in a sequence or in groups using a single, self-determined attribute. (Math PR-I.1.0) GLO: C2, C3, C5</p>

- **Viewing Coloured Objects**
Display two objects of the same colour that are of different tints or shades. Ask students the following questions:
 - Which colour is lighter?
 - Which colour is darker?
 Repeat with several different coloured pairs.
- **Sorting Coloured Objects by Value**
Provide a set of objects of the same colour that range from light to dark. Have students work in pairs to arrange items from lightest to darkest or darkest to lightest. Hint: Have students squint at the colours in order to see which shade or tint of the colour is lighter or darker.
- **Comparing Coloured Strips by Value**
Prepare colour strips in which the colours are either dark or light and distribute one strip to each student. Have students hold up the colour that is named by the teacher. These students can then be asked to group themselves according to the darker shades of the colour or lighter shades of the colour. Example: lighter reds stand here, darker reds stand there.

Art Extension: Give each student one coloured tempera block and either one black or one white tempera block. Demonstrate how to make a colour lighter or darker by gradually mixing more and more white or black with the pure colour. Have students try this exercise using their dabs of mixed colour on manila paper.

(continued)

TEACHER NOTES

SUGGESTIONS FOR ASSESSMENT

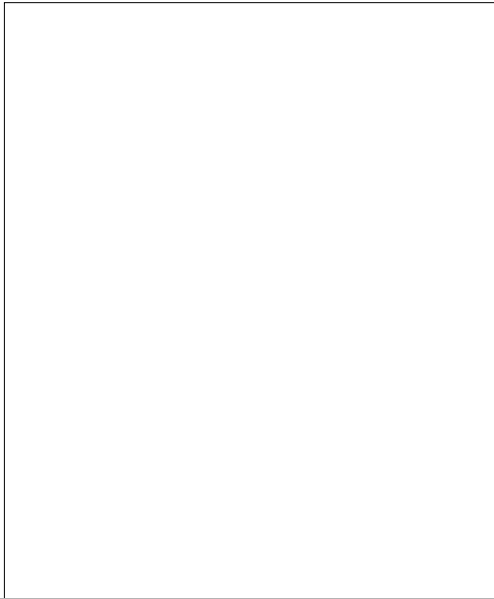

Commercially available, sample strips for paint are good sources for colours of different shades/tints.

The term “value” refers to the amount of light or dark in a colour. Example: A light, sky blue is of higher value than a navy blue. The navy blue has less white in it and is of lower value. Value (light/dark), intensity (bright/dull), and hue (colour) are three variables that artists use to talk about colour.

Paper and Pencil Task: Ordering Colours

Provide students with four paper strips or paint samples. The strips or samples should be variations of the same colour. Have the students order them from lightest to darkest and then glue them in order onto a piece of paper.

PRESCRIBED LEARNING OUTCOMES

SUGGESTIONS FOR INSTRUCTION

Students will...

➤ **Ordering Coloured Strips by Intensity**
Provide students with paint strips of varying intensities in a variety of colours. Be sure to include neon colours as well as dull colours. Have students order the strips from brightest to dullest.

K-2-05 Predict and describe changes in colour that result from the mixing of primary colours and from mixing a primary colour with white or black.
GLO: C2, D3

➤ **Making Colour Splashes**
Have students fold a small piece of heavy paper in half and then open it up. Using tempera or finger paint, have students put a blob of one primary colour on one half and a different primary colour on the other half. Have students predict what will happen when they refold the paper and press. Have students test their predictions by folding and pressing. As they re-open the paper, use the following questions for discussion:

K-0-1b. Make predictions as to what might happen during explorations. (ELA 1.2.1) GLO: A1, C2
K-0-2a. Seek information from others.
Examples: people at school, at home, in the community... (ELA 3.2.2, 3.2.4; Math SP-II.1.0) GLO: C6
K-0-4e. Participate in cooperative group learning experiences. (ELA 5.2.1) GLO: C7
K-0-5c. Record observations using drawings. (ELA 4.1.2, 4.2.5) GLO: C6

- What two colours did you start with?
 - What colour do you see now?
 - What do you think will happen if you repeated this activity?
 - What have you learned from this investigation?
- Have students repeat the procedure using new paper and different colours of paint. Students should make predictions about what the resulting colour might be.

➤ **Investigating Colour — Combining Primary Colours**
At the Art/Science Centre provide yellow, red, and blue tempera or finger paint. Have students investigate to determine the results of mixing combinations of these colours. Have students record their findings. Example:

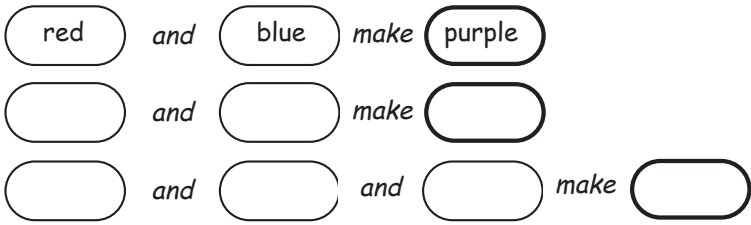

As a class, discuss the findings.

(continued)

TEACHER NOTES

SUGGESTIONS FOR ASSESSMENT

In the traditional colour wheel used by artists, the primary colours are red, yellow, and blue. This colour wheel illustrates the location of the secondary colours: orange, green, and purple. It shows that mixing red and yellow produces orange; mixing blue and yellow produces green; and mixing red and blue produces purple.

The scientists' (physicists') colour wheel is less well-known. It includes the primary colours of yellow, magenta, and cyan. The emphasis of Cluster 2: Colours is to have students identify common colours and understand colour mixing. It is not necessary to use the scientists' colour wheel. Most learning resources reference the artists' colour wheel.

Performance Task: Combining Primary Colours

Scale	Follows Directions	Records Findings
4	independently completes the activity	records findings independently
3	requires additional directions to complete the activity	records findings independently
2	requires some assistance to complete the activity	records findings with some assistance
1	requires direct assistance to complete the activity	records with direct assistance

Science Journal Entry

Have students show what happens when black and white paints are mixed with the primary colours.

Note: This is not intended to be a teacher-created record. Students should be encouraged to develop their own way of recording.

PRESCRIBED LEARNING OUTCOMES

SUGGESTIONS FOR INSTRUCTION

Students will...

Add white and black paint to the centre. Have students repeat their investigations and record their findings. (Link to K-2-04 Art Extension, making colours lighter or darker.)
 Discuss the results in a Sharing Circle. (See *ELA, Strategies*, p. 106.) Use the following questions to guide the discussion:

- What changes did you see when you used white paint with another colour?
- What changes did you see when you used black paint with another colour?
- Can you make or match a colour that another classmate has made?

K-2-06 Create a colour to match a given sample by mixing the appropriate amounts of two primary colours.
 GLO: C3, D3

➤ **Matching Colours**
 At the Art/Science Centre provide yellow, red, and blue paint and “colour cards” made by mixing various amounts of each of the primary colours. Have students explore colour mixing to create a match for each colour card.

K-0-8a. Recognize that learning can come from careful observations and investigations. (ELA 3.3.4) GLO: A1, A2, C2
K-0-9b. Willingly observe, question, and explore. GLO: C5

K-2-07 Explore to identify and describe colours found in their environment.
Examples: rocks, flowers, shells, blocks, crayons...
 GLO: C2, D3

➤ **Observing the Environment: Colour Walk**
 On a walk around the neighbourhood or school grounds, have the students look for and identify colours in the environment. Encourage them to ask questions about what they see. Focus their observations with the following questions:

- What colours can you see?
- Which colour is the lightest?
- Which colour is the darkest?
- Which colour do you see the most often? Why?

K-0-1a. Ask questions that demonstrate a curiosity about living things, objects, and events in the immediate environment. (ELA 1.2.4, 3.1.2, 3.1.3) GLO: A1, C2, C5
K-0-4d. Respond to the ideas and actions of others. (ELA 1.1.2) GLO: C5, C7
K-0-4f. Verbalize questions during classroom learning experiences. GLO: C6
K-0-5a. Observe using one or a combination of senses. GLO: C2
K-0-9c. Express enjoyment of science-related classroom activities. GLO: C5

(continued)

TEACHER NOTES

SUGGESTIONS FOR ASSESSMENT

In Kindergarten, students will have difficulty creating an exact colour match. However, they should begin to recognize which two colours are required to make a third.

Observation Checklist: Matching Colours

The student

- willingly participates in the activity
- understands the directions given
- keeps trying until satisfied with the results
- records findings in pictures
- attempts writing
- works cooperatively
- shares the materials
- discusses findings with others

Discuss with students which objects can be collected and which ones cannot. Reinforce respect for living things and safety procedures.

PRESCRIBED LEARNING OUTCOMES

Students will...

SUGGESTIONS FOR INSTRUCTION

➤ **Read Aloud**

Read aloud books about colour and encourage students to talk about the colours they recognized and how colour was used by humans and other living things.

Art Extension: Have students examine a number of story books/art illustrations. Focus student observation and discussion on the range and variety of colours employed.

➤ **Writing Centre**

Have students use the following frame sentences to write their own colour book.

A _____ is red.

A _____ is red.

A _____ is not red.

TEACHER NOTES

SUGGESTIONS FOR ASSESSMENT

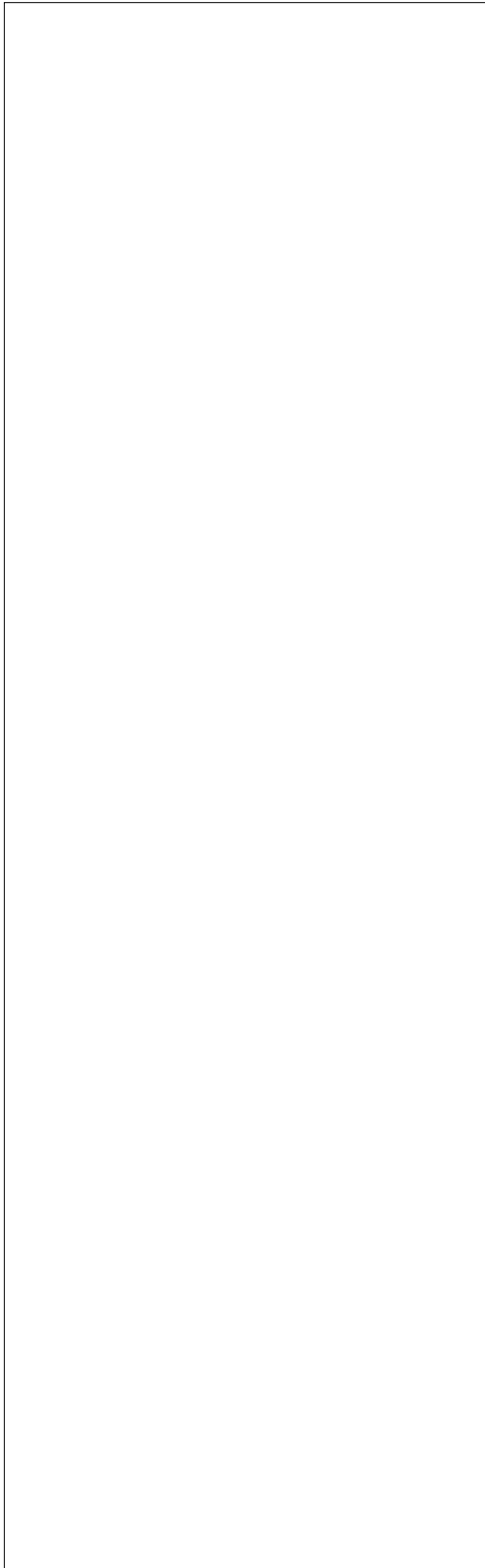

NOTES

Kindergarten

Cluster 3: Paper

Overview

By identifying, describing, and manipulating different kinds of paper and paper products found in the classroom, students are introduced to the concept of characteristics of materials. Hands-on investigations allow students to determine how well different kinds of paper can be cut, torn, and folded, and how these characteristics help to determine their uses. This study of paper culminates in students' developing their design-process skills by constructing a paper product for a particular use.

PRESCRIBED LEARNING OUTCOMES	SUGGESTIONS FOR INSTRUCTION
<p><i>Students will...</i></p> <p>K-3-01 Use appropriate vocabulary related to their investigations of paper. Include: characteristic, thick, thin, hard, soft, smooth, rough, absorbent, pliable. GLO: C6, D3</p>	<p>➤ Introduce, explain, use, and reinforce vocabulary throughout this cluster.</p> <p>➤ Object Wall with Words Cover one bulletin board with paper. Draw and label columns with the words thick, thin, hard, soft, smooth, rough, absorbent, and pliable. Glue one sample of paper under each heading. During the study of this cluster give students opportunities to add other types of paper under the headings.</p>
<p>K-3-02 Identify kinds of paper that can be found in the classroom. <i>Examples: drawing paper, paper towels, paper plates, books, newspaper, cardboard, tissue paper...</i> GLO: B1</p> <p>K-3-03 Recognize that paper is most often made from trees. GLO: D3</p>	<p>➤ Classroom Conversation — What Is Paper? Hold up several different objects made of paper, such as a cardboard box, toilet paper roll, construction paper kite, or tissue paper flower. Ask students to identify each object, and encourage questions about the objects. Have students explain how all the objects are the same.</p> <p>➤ Paper Scavenger Hunt Put many different paper objects around the room, e.g., toilet paper rolls in the art bin, paper plates, paper cups, cardboard box, tissue butterflies, paper fans, etc. Make sure there is at least one object for each child in the class. Have each student find one object in the room that is made of paper and bring it back to the group. Use the following questions to guide the students' discussion about the paper objects they found:</p> <ul style="list-style-type: none"> • What does the paper object feel like? • What colour is the paper object? • What is the object used for? • How are all of the paper objects the same? Different? • Why do people use paper for so many things?
<p>K-0-1a. Ask questions that demonstrate a curiosity about living things, objects, and events in the immediate environment. (ELA 1.2.4, 3.1.2, 3.1.3) GLO: A1, C2, C5</p> <p>K-0-2b. Compare gathered ideas and information to personal knowledge. (ELA 3.2.3, 3.3.3; Math SP-IV.1.0) GLO: C6, C8</p> <p>K-0-5a. Observe using one or a combination of senses. GLO: C2</p>	<p>➤ How Is It Made? Ask students to share what they know about how paper is made. Show a video, use a CD-ROM, or read a book to describe the process of making paper from trees. Help students make links with their learning about trees from Cluster 1. Ask students to share what they learned about making paper.</p>

TEACHER NOTES

SUGGESTIONS FOR ASSESSMENT

Note: It is not expected that students at the Kindergarten level read the vocabulary words without support.

Words should be presented along with illustrations that demonstrate meaning and cue students into using the words orally.

Example:

Thick  Thin 

Science Journal Entry: Paper

Have students record in their science journals what they learned about making paper by asking, “How is paper made?” Have students use pictures and words to show what they have learned.

Students in Grade 3 may be making paper as part of Cluster 3: Growth and Changes in Plants (3-1-17). This would be a good opportunity for the Grade 3 students to share with the Kindergarten students what they did.

Students will continue to describe and compare the paper samples they are using throughout the cluster, improving their ability to observe and describe what they see.

PRESCRIBED LEARNING OUTCOMES

SUGGESTIONS FOR INSTRUCTION

Students will...

K-3-04 Observe and compare characteristics of different kinds of paper.
Examples: compare colour, thickness, stiffness, texture...
 GLO: C2, D3

➤ **Sort and Classify**
 Have students work in pairs to sort and classify a variety of paper samples using their own criteria. Have students explain the reasons for their classification.

K-0-4d. Respond to the ideas and actions of others. (ELA 1.1.2) GLO: C5, C7
K-0-4e. Participate in cooperative group learning experiences. (ELA 5.2.1) GLO: C7
K-0-6c. Place materials and objects in a sequence or in groups using a single, self-determined attribute. (Math PR-1.1.0) GLO: C2, C3, C5

K-3-05 Compare characteristics of different kinds of paper that make them easy or difficult to cut, tear, or fold.
Examples: cardboard is thicker than newsprint and harder to fold...
 GLO: D3, E1

➤ **Paper Sculpture Centre**
 Set up a centre with a variety of paper scraps, glue, construction paper, and heavy cardboard (for the base). Provide samples of different ways of folding, crumpling, cutting, and curling paper to make a three-dimensional collage or paper sculpture. Include books on different kinds of paper folding and paper sculpture at the centre. Instructions to the students will direct them to cover their entire base with a variety of paper pieces, in a variety of forms (crumpled, folded, etc.) Types of paper could include tissue paper, cardboard, wax paper, paper towel, manila tag, construction paper, corrugated cardboard, newsprint, etc. Each day, have some students share and describe their sculptures to the class. Use the following questions to help guide the sharing:

- What kinds of paper are on your sculpture?
- Which paper was the roughest? Smoothest?
- How many different things were you able to do with your paper?
- Which paper was the most difficult to cut? Tear? Why?
- Which paper was the most difficult to fold? Why?

K-0-4a. Manipulate materials purposefully. GLO: C1, C2
K-0-4g. Follow given safety procedures and rules. (ELA 2.1.2) GLO: C1
K-0-5a. Observe using one or a combination of senses. GLO: C2
K-0-8a. Recognize that learning can come from careful observations and investigations. (ELA 3.3.4) GLO: A1, A2, C2
K-0-9a. Be open-minded while exploring. GLO: C5

(continued)

TEACHER NOTES

SUGGESTIONS FOR ASSESSMENT

[Empty box for teacher notes]

Interview: Collage and Folding Paper

The same paper samples used in the Paper Sculpture Centre should be used for the interviews.

1. Have the student sort the samples using his/her own criteria.
The student
 sorts correctly according to his/her own criteria
 labels the sorting rules explains his/her choices
2. Have the student identify which of the paper samples is
 the easiest to cut the hardest to cut
3. Have the student identify which of the paper samples is
 the easiest to fold the hardest to fold
4. Have the student identify which of the paper samples is
 the easiest to tear the hardest to tear
5. Ask student which paper she/he would use to make a paper box to hold something, and to explain why.
 student selects appropriate paper type
 student's explanation includes references to folding, tearing, and/or cutting

Comments: _____

PRESCRIBED LEARNING OUTCOMES
<i>Students will...</i>

SUGGESTIONS FOR INSTRUCTION

➤ **Folding Paper**

Prepare sealable bags containing scraps of different types of paper, such as manila tag, newsprint, construction paper, tissue paper, bond paper, crepe paper, and notebook paper for each table. Explain to the students that they will be doing an origami activity (Japanese art form of folding paper) but the class must first determine the best paper for folding. Have the students explore by folding the different types of paper found in the bag (fold the paper in half, then in half again, etc.). After the exploration, have students select which paper they think would be best for doing origami. Discuss their findings using the following questions:

- Which paper is easiest to fold?
- How many times could you fold each paper?
- What characteristics of paper might be important for origami?

➤ **Origami**

Obtain books on origami from the library and as a class select a project to complete. Or, have students make an origami bird, following directions provided in the Teacher Notes.

TEACHER NOTES

SUGGESTIONS FOR ASSESSMENT

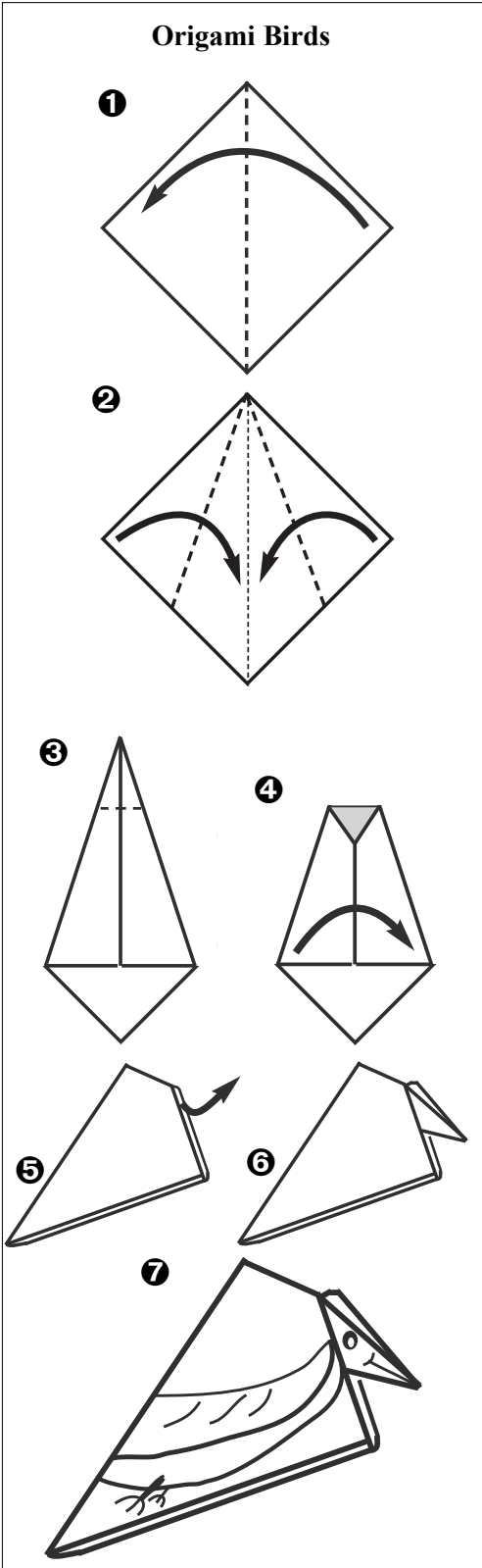

PRESCRIBED LEARNING OUTCOMES
<i>Students will...</i>
<p>K-3-06 Explore to determine an appropriate kind of paper for a particular task.</p> <p><i>Examples: paper towels are useful for soaking up spills...</i></p> <p>GLO: B1, C3</p>
<p>K-0-1b. Make predictions as to what might happen during explorations. (ELA 1.2.1) GLO: A1, C2</p> <p>K-0-4e. Participate in cooperative group learning experiences. (ELA 5.2.1) GLO: C7</p> <p>K-0-4f. Verbalize questions during classroom learning experiences. GLO: C6</p> <p>K-0-5a. Observe using one or a combination of senses. GLO: C2</p> <p>K-0-7a. Recognize connections between new experiences and prior knowledge. (ELA 1.2.1) GLO: A2</p> <p>K-0-7b. Describe, in a variety of ways, what was done and what was observed. <i>Examples: concrete materials, drawings, oral language....</i> (ELA 4.1.2, 4.1.3) GLO: C6</p> <p>K-0-9b. Willingly observe, question, and explore. GLO: C5</p> <p>K-0-9c. Express enjoyment of science-related classroom activities. GLO: C5</p>

SUGGESTIONS FOR INSTRUCTION

➤ **Paper for Writing**

Provide small groups of students with pencils, crayons, and markers. Tell them that their task is to find out which paper is best for writing a letter. Each group should have a selection of 3 types of paper. Use photocopier paper, tissue paper, corrugated cardboard, wax paper, construction paper, etc. Different groups can look at different samples of paper. Have students begin by looking at the samples and discussing with their group how they are the same and how they are different (e.g., thickness, texture, colour, etc.). Have students draw the same image (flower, leaf, etc.) on each sample with the pencil and then repeat the drawing with the crayon and then the marker. Have each group share their observations and guide the sharing with the following questions:

- What did you observe when you wrote on each sample with the pencil, the crayon, and the marker?
- Which paper was best for writing on with the marker? Crayon? Pencil?
- Which kind of paper was hardest to write on? Why?
- If you were writing a note with a pencil, which paper would you choose to write on? Why?

➤ **Paper for Painting**

The following day, repeat the **Paper for Writing** procedure using water-colour paints with the same types of paper. Have students make predictions based on their previous experiences about what might happen. Have students use the paints to determine which paper is best for this activity and share their findings with the class.

➤ **Paper for Spills**

Tell students they must now determine which is the best paper for soaking up spills. As a class, select three types of paper to test. Working in small groups, have students put the paper sample over a clear plastic cup. Using an eye dropper, have students drop water onto the paper sample one drop at a time until the water soaks through and drips into the cup. Remind the students to count each drop they put onto the paper towel. Have students record and then discuss their results using terms like “more” or “less.” Have students order the samples according to how many drops they could hold.

Each group should share their recommendations with the class about the best paper for spills and explain their reasoning.

TEACHER NOTES

SUGGESTIONS FOR ASSESSMENT

Observation Checklist: Paper for Writing, Painting, and Spills

Throughout the explorations of paper, observe and note evidence of the following skills and attitudes:

The student

- willingly observes, questions, and explores
- expresses enjoyment of the learning experiences
- asks questions related to use of paper
- works cooperatively
- is persistent and completes task

PRESCRIBED LEARNING OUTCOMES

SUGGESTIONS FOR INSTRUCTION

Students will...

K-3-07 Use the design process to construct a paper product for a particular use.
Examples: paper cup, envelope, paper mat, box...
 GLO: C3

K-0-1c. Recognize a practical problem in a given context. GLO: C3
K-0-3a. Brainstorm, with the class, possible solutions to a practical problem, and reach consensus on a solution to implement. (ELA 1.2.3, 3.1.3) GLO: C3, C7
K-0-3b. Develop, as a class, limited criteria to evaluate an object based on its function. GLO: C3, C7
K-0-4b. Construct an object to solve a problem or meet a need. GLO: C3
K-0-4c. Identify, with guidance, improvements to an object with respect to pre-determined criteria. GLO: C3

➤ **Design Project**

Provide a context for the design project. This context can come from literature or from a real-life problem. A real-life example could be that students need to prepare for a special lunch for parents. They don't have a budget to purchase supplies and so must make their own. Things needed for the party could include any or all of the following items:

- place mats (woven paper)
- paper cups
- boxes (or square bowls)
- party hats
- invitations (including envelopes)

In planning how to construct one of these items, encourage students to take apart an existing product to use as a template or model. For example, they might take apart and trace a small gift box or envelope. Once a plan has been decided upon, the class must address the question of which type of paper would be best suited to the object. Example: Wax paper for a cup that will hold a liquid; paper that holds its shape but is easy to fold for an envelope. The class must develop clear evaluation criteria that focus on the objects' intended use. For example, what will the "bowl" need to hold? Remind students to follow given safety procedures and rules. Help students identify improvements for the objects once the initial construction has taken place.

TEACHER NOTES

SUGGESTIONS FOR ASSESSMENT

Design Process Checklist

The student

- understands the problem
- contributes to class brainstorming of possible solutions
- contributes to the development of criteria
- constructs the object
- tests the object
- suggests possible improvements
- works cooperatively
- shares tools and materials
- asks related questions

NOTES

Grade 1 Science

Grade 1

Cluster 1: Characteristics and Needs of Living Things

Overview

Students in Grade 1 are interested in a wide variety of living things found in their local environments as well as in those from afar. In this cluster, a study of living things provides opportunities for students to discover the many different forms life takes. Students observe similarities and differences among living things and develop an understanding of their general characteristics. As a result, students become aware that all living things, including themselves, have needs. They discover that living things can often have similar needs, but that particular needs may be unique to individual living things. While the emphasis is on shared characteristics and needs among living things, diversity is also recognized, including the variations that make each human unique.

PRESCRIBED LEARNING OUTCOMES

SUGGESTIONS FOR INSTRUCTION

Students will...

1-1-01 Use appropriate vocabulary related to their investigations of characteristics and needs of living things.

Include: characteristic, human, animal, plant, living things, needs, as well as descriptive words relating to life processes.

GLO: C6, D1

➤ Introduce, explain, use, and reinforce vocabulary throughout the cluster.

1-1-02 Identify major parts of the human body and describe their functions.

Examples: arms and legs for movement...

GLO: D1, E2

➤ **Human Body Parts**

Brainstorm a list of external body parts of human beings. Have students indicate the function of each body part.

Example:	Body Part	Function
	eyes	seeing
	2 legs	moving
	2 arms	carrying things

1-0-4f. Work in cooperative partnerships and groups. (ELA 5.2.1) GLO: C7

Teachers can use this opportunity to include and use words and phrases for body parts from a variety of languages such as Native languages (*Native Studies: Early Years (K-4)* p. 35).

(continued)

(continued)

TEACHER NOTES

SUGGESTIONS FOR ASSESSMENT

This cluster focusses on the characteristics and needs of living things. Students should not undertake any extensive classifying of things as living and/or non-living. This could result in confusing complications around things that were “once living”; or may be considered as “living” by different cultures.

This cluster has strong links with *Native Studies: Early Years (K-4), Grade 1, Unit One*. Refer to this document for further instructional suggestions.

It is important that children be familiar with their own external body parts before beginning the comparison with other animals.

Teachers will need to show sensitivity to differently-abled and special-needs students.

Observation: “Show Me”

Work with small groups. Give the following instructions:

We are going to play a game called “Show Me.” I am going to give you a clue about one part of your body. I want you to point to that part on your body.

- This body part lets you see.
- This body part lets you touch or grab things.
- This body part lets you hear.
- This body part lets you eat, speak, and smile.
- This body part covers your whole body.
- This body part lets you walk.

Make a note of those students who are unsure or unable to identify the body part with its function.

PRESCRIBED LEARNING OUTCOMES

SUGGESTIONS FOR INSTRUCTION

Students will...

➤ **Body Tracing**

Have students work with partners to trace each other’s body outlines. Have them add body parts to the drawings that were not originally traced (e.g., ears, nose, mouth, fingers, hair, eyes, fingernails). Post the tracings and use a Gallery Walk (Brownlie and Close, 1992) to facilitate sharing. (*Gallery Walk* is outlined in *ELA, Strategies*, pp. 202-203.) Discuss the tracings, using the following questions for reflection:

- What body parts did you trace?
- What body parts did you not trace?
- What can you add to your traced body to make it more like you really are?
- What parts does everyone have?

➤ **Animal Observation**

Provide a large picture of an animal for the whole class to study or provide copies of an animal picture for each student. Have students observe the animal closely to identify and discuss its body parts.

➤ **Animal Observation and Drawing**

Have students draw an animal they have observed and have them label external body parts using cut-and-paste labels.

1-1-03 Identify and describe common characteristics of humans and other animals they have observed.

Examples: number of limbs, eyes, ears, skin...

GLO: D1, E1

1-1-04 Identify and appreciate variations that make each human unique.

Examples: eye colour, hair colour, body type...

GLO: C5, E1

1-0-5e. Record observations using drawings and tally charts.

(ELA 4.1.2., 4.2.5; Math SP-II.1.1)

GLO: C2, C6

1-0-6c. Place materials and objects in a sequence or in groups using a single, given attribute or a single, self-determined attribute.

(Math SP-IV.2.1)

GLO: C2, C3, C5

➤ **Animal/Human Comparison**

Have students observe pictures of other animals and discuss the similarities between the external body parts of animals and humans. Use a Venn diagram to show the comparisons.

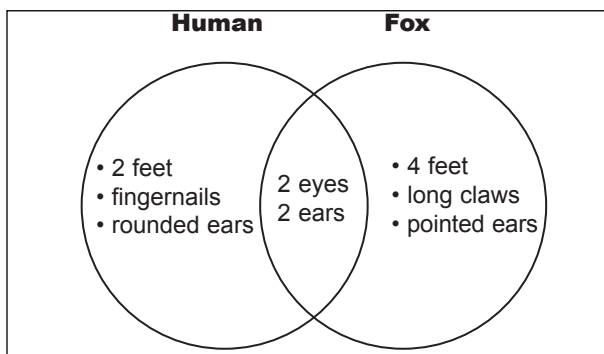

➤ **Math Centre**

Have students collect data related to human variations (e.g., eye colour, hair colour, etc.) Have them, with guidance, represent their data on a concrete object graph or pictograph.

TEACHER NOTES

SUGGESTIONS FOR ASSESSMENT

Children will benefit from observing a live animal, such as a classroom pet. See Appendix C for safety considerations related to pets in the classroom.

It is important to tell the children that when scientists make drawings, they try to make them look the same as the real animal, e.g., same colour and markings.

Paper and Pencil Task: Body Tracing

To assess knowledge of major body parts, have students draw a picture of themselves and attach the correct labels.

Draw a picture of yourself. Cut out the words below. Use them to label your picture.

leg	ear	arm	eye	skin
mouth	hand	nose	foot	

1. Drawing includes

- | | | | |
|-------------------------------|--------------------------------|-------------------------------|--|
| <input type="checkbox"/> legs | <input type="checkbox"/> mouth | <input type="checkbox"/> eyes | <input type="checkbox"/> other (fingers, eyebrows, toes, etc.) |
| <input type="checkbox"/> arms | <input type="checkbox"/> skin | <input type="checkbox"/> ears | |
| <input type="checkbox"/> feet | <input type="checkbox"/> hands | <input type="checkbox"/> nose | |

2. Correct labels are attached for

- | | | | |
|-------------------------------|--------------------------------|-------------------------------|--------------------------------|
| <input type="checkbox"/> leg | <input type="checkbox"/> mouth | <input type="checkbox"/> eye | <input type="checkbox"/> other |
| <input type="checkbox"/> arm | <input type="checkbox"/> skin | <input type="checkbox"/> ear | |
| <input type="checkbox"/> foot | <input type="checkbox"/> hand | <input type="checkbox"/> nose | |

PRESCRIBED LEARNING OUTCOMES

SUGGESTIONS FOR INSTRUCTION

Students will...

1-1-05 Recognize that plants, as living things, come in different forms.
Examples: grass, trees, shrubs...
GLO: D1, E1

1-0-4g. Verbalize questions and ideas during classroom learning experiences.
GLO: C6
1-0-6c. Place materials and objects in a sequence or in groups using a single, given attribute or a single, self-determined attribute. (Math SP-IV.2.1)
GLO: C2, C3, C5

1-1-06 Observe and identify similarities in life processes between themselves and other living things.
Examples: they eat, sleep, grow, and breathe, and so do other living things...
GLO: D1, E1

1-1-07 Recognize that plants, animals, and humans, as living things, have particular needs.
Examples: plants need sunlight and water...
GLO: D1

1-0-1a. Ask questions that lead to explorations of living things, objects, and events in the immediate environment. (ELA 3.1.2, 3.1.3)
GLO: A1, C2, C5

(continued)

➤ **Observing the Environment**
Take students on a walk to observe the plants in their neighbourhood. Provide each student with a collection bag and ask students to collect a variety of leaf samples. Limit the number of samples. Discuss and model respect for plants as living things (link to 1-1-14). After returning to the class, discuss the following questions:

- How many different kinds of plants did you observe?
- How can you group the different plants you found? (Encourage general categories such as grasses, trees, and shrubs.)

➤ **Sort and Classify Leaves**
Have students sort and classify the leaves that were collected; examples include: rounded leaves, pointed leaves, leaves with veins, smooth leaves, fragrant leaves. Encourage students to use smell and feel, as well as sight (link to Cluster 2: The Senses).
Extension: As a class, make an ABC Big Book of Plants. (A is for apple tree, B is for buttercup...)

➤ **Pet Observations**
Have students observe a live animal over the course of a week. Have them take turns being responsible for changing the water, feeding, and cleaning up after the pet. Emphasize respect for living things (link to 1-1-14 **Pet Rules!**). Use a class log book in which students record their observations and their care of the animal. Provide opportunities for students to observe the pet at different times of the day in order to allow them to observe the pet active, asleep, as well as eating and drinking.
Using a Sharing Circle, discuss observations of the pet, utilizing the following questions for reflection:

- What types of activities did the pet do during the day?
- How did you feel when you had the responsibility for caring for the pet?

(See Sharing Circle in *ELA, Strategies*, p. 106).

➤ **How Are We Like Our Pets?**
Use the Think, Pair, Share strategy (McTighe and Lyman, 1992) to have students discuss the similarities between a pet and themselves. Record responses using words and pictures.
Extension: If students have observed a mammal, have them observe another animal such as a fish, bird, reptile, insect or amphibian (see Think-Pair-Share/Think-Pair-Square in *ELA, Strategies*, pp. 15-16).

(continued)

TEACHER NOTES

SUGGESTIONS FOR ASSESSMENT

Students will benefit from seeing and handling plants of varying kinds and sizes, including both indoor and outdoor plants. Emphasize the variety in plants.

Caution: Check for plant allergies prior to bringing plants into the classroom. Many common house plants are poisonous if ingested, so select plants carefully.

Science Journal Entry: Leaves

Have students write or draw about the leaves that they collected and sorted.

Observing Leaves

I learned that leaves. . .

Expect some reference to shape (rounded, pointed); texture (smooth, soft, rough); smell; and structure (veins, no veins).

Students may say that leaves are living things, leaves come from different plants, etc.

Caution: Be sure to check for allergies before bringing a pet to the classroom.

If it is not possible to observe the activities of an animal in the classroom, students can observe their own pets or livestock at home. As an alternative, use books, videos, or multimedia resources.

PRESCRIBED LEARNING OUTCOMES

SUGGESTIONS FOR INSTRUCTION

Students will...

➤ **The Trip**

As a class, discuss what a family would need to take with them for a two-week stay at a cabin that is only accessible by boat. Tell the students that there is no electricity, running water, gas, or oil at the cabin. Everything they need has to be carried in with them. The students should brainstorm to decide what the family will take with them and provide reasons for choosing each item.

This activity is a variation of the Trapline Activity in *Native Studies: Early Years (K-4)* p. 41 and can be modified to suit local situations.

➤ **Plant Investigation: How Does It Grow?**

As the focus shifts from animals to plants, encourage students to ask questions about what plants need to survive. Keep a list of questions visible, and brainstorm ways to find answers to the questions. The following investigation can help students find some of the answers.

Use three plants of the same type and size. Measure the height of the three plants and record the information on an observation sheet. Put the first plant inside a box to block the sunlight but continue to water it once a week. Put the second plant in the sun but do not add water. Place the third plant in the sunlight and water it once a week. Keep a record of how the plants are doing as you focus on the learning outcomes that comprise this cluster. Observe the plants once a week and record observations in words and pictures. At the end of several weeks, review the observations and have students record in their science journals what they learned.

1-1-08 Describe what is needed to care for a pet, a farm animal, or an indoor plant.

Examples: provide fresh water for their hamster daily, feed and bed calves regularly...

GLO: B4, B5

➤ **“How to” Illustrations**

Have students work with partners to identify the basic needs and the care required for pets, indoor plants, and humans. Have students cut and paste or draw pictures as well as write words and phrases to illustrate the basic needs and care required for these living things.

1-0-7d. Connect new experiences and information with prior knowledge.

(ELA 1.2.1)

GLO: A2

TEACHER NOTES

SUGGESTIONS FOR ASSESSMENT

A discussion about the differences between needs and wants should emerge from this learning experience. It is important for students to be able to identify the basic things they need to survive and how, in this respect, they are no different from any other living thing.

It is not easy for students to recognize the life processes and needs of plants. The suggestions given are meant to highlight a plant's need for water and light. A more detailed study of plants occurs in Grade 3.

Have students use Blackline Master 1: Scientific Inquiry Recording Sheet: Grades 1 and 2.

Performance Assessment: "How to" Illustrations

Say to students: Imagine that you are getting a dog for a pet. What do you need for your dog? How will you care for your dog? Explain, using pictures and words.

Scoring Rubric

Note: Explanations may include pictures and/or words.

- 4** solid understanding of the needs of living things; four basic needs (food, water, air, and shelter) identified; clear and complete explanation
- 3** good understanding of the needs of living things; three basic needs identified; clear explanation
- 2** basic understanding of the needs of living things; two basic needs identified; explanation may or may not be clear
- 1** limited understanding of the needs of living things; one basic need identified; explanation unclear or incomplete

PRESCRIBED LEARNING OUTCOMES
<i>Students will...</i>
<p>1-1-09 Compare ways in which humans and other animals meet their needs. <i>Examples: senses, locomotion, tools...</i> GLO: C2, D1, E1</p> <p>1-1-10 Describe how humans and other living things depend on their environment to meet their needs. <i>Examples: the environment provides humans and other living things with food...</i> GLO: D2, E2</p>
<p>1-0-2a. Access information using a variety of sources. <i>Examples: picture and concept books, people, excursions, camps, CD-ROMs...</i> (ELA 3.2.2, Math SP-II.1.1, TFS 2.1.1) GLO: C6</p> <p>1-0-6c. Place materials and objects in a sequence or in groups using a single, given attribute or a single, self-determined attribute. (Math SP-IV.2.1) GLO: C2, C3, C5</p> <p>1-0-9b. Willingly observe, question, and explore. GLO: C5</p>
(continued)

SUGGESTIONS FOR INSTRUCTION

- **Picture Sort**
 Have students work with a partner to sort a variety of animal pictures according to specified categories. Include categories such as how animals move, the foods animals eat, how animals get their food, and where animals live. Have students discuss their picture sort and observe how others sorted their pictures.

- **Science Centre Matching Game**
 Animals move in different ways within their habitats in order to capture food or to escape from their enemies. Set up a matching game at the Science Centre in which students match the feet or footprints of different animals with the actual animal. Be sure to include webbed feet, split hooves, talons, and claws. Discuss student findings using the following questions for reflection:
 - Where might these animals live?
 - Which animals would be the best swimmers? Why?
 - Which feet might be good for climbing? Why?
 - How do an animal’s feet help it to survive in its environment?

- **Investigation — Meeting Needs**
 Have students work with partners to answer questions and identify ways in which humans and other animals meet their needs through their environments. Encourage students to record what they already know about the topic before they read or view texts, videos, or CD-ROMs to get additional information. Questions to guide the investigation could include the following:
 - Which senses do animals use to meet their needs?
 - How do animals move to obtain their food?

Example: How Senses Are Used to Meet Needs

<u>Animal</u>	<u>What I Know</u>	<u>What I Found out</u>
rabbit	uses eyes to look for food	uses smell
hawk	uses ears to listen for food	uses sight
bat	uses ears to listen for food	uses hearing and echolocation

- **Ten Key Questions**
 Give one student a picture of an animal. Have the other students ask questions that can be answered with yes or no about how the animal meets its needs.

(continued)

TEACHER NOTES

SUGGESTIONS FOR ASSESSMENT

Student Interviews: Meeting Needs

For this assessment activity gather the following materials:

- a picture of a person
- a picture of a mammal
- a picture of a different animal (bird, fish, etc.)

Ask individual students the following questions. Record their responses. Note any misconceptions they may have.

1. What are the basic needs of all living things?
 food water air shelter
2. How does a person meet his/her needs? (Use the picture of the person.)
How does the person get food? water? air? shelter?
3. How does this animal meet its needs? (Use the picture of the mammal.)
How does it get food? water? air? shelter?
4. How does this animal meet its needs? (Use the picture of a different animal.)
How does it get food? water? air? shelter?
5. How do senses help animals and humans meet their needs?

PRESCRIBED LEARNING OUTCOMES

SUGGESTIONS FOR INSTRUCTION

Students will...

➤ **Humans in the Environment**

“Physical needs are universal. Native people met and continue to meet these physical survival needs in a variety of ways. The Elders play an important role in providing understanding about survival” (see *Native Studies: Early Years (K-4)*).

Have students research and share traditional stories that illustrate the interdependence between Native cultures and the environment. Invite a storyteller to visit the class, or view First Nations’ art objects and images that show this interdependency.

➤ **Our Community**

Have students identify how people in their community depend on the environment. Have students discuss where they get their food.

1-1-11 Design a representation of an environment that meets the needs of a Manitoba animal.
Examples: a model, a diagram
GLO: C3, D1

➤ **Designing an Environment**

Set the context by saying to the class: “We have discovered that every animal in Manitoba has basic needs that include air, food, and water as well as shelter from the weather in order to survive. Today we are going to design a three-dimensional environment for a Manitoba animal that meets that animal’s needs.” The following is one approach to designing an environment that could be taken with students.

- ❶ Brainstorm and chart different Manitoba animals.
- ❷ As a class, develop criteria for evaluating the final product such as
 - provides for the basic needs of food, water, shelter
 - looks visually appealing
 - uses the materials provided
- ❸ As a class, discuss the general plan for completing this project.
- ❹ Working in cooperative groups, have each group choose an animal and begin their research using a variety of information sources such as library books, CD-ROMs, Internet...
- ❺ Have students draw a simple plan for their environment.
- ❻ Have students construct their environment based on the plans they drew.
- ❼ Have students use the criteria identified to evaluate their finished product and suggest improvements.

Have students use Blackline Master 3: Design Process Recording Sheet: Grades 1 and 2.

1-0-1c. Recognize a practical problem in a given context. GLO: C3
1-0-3a. Brainstorm, with the class, possible solutions to a practical problem, and reach consensus on a solution to implement. (ELA 1.1.3, 3.1.3) GLO: C3, C7
1-0-3b. Create, with the class, a plan to solve a problem or meet a need. Include: identify simple steps to follow. (ELA 1.2.3) GLO: C3, C7
1-0-3c. Develop, as a class, limited criteria to evaluate an object or device based on its function. GLO: C3, C7
1-0-3d. Identify materials to be used, and explain their choices. GLO: C2, C3, C4
1-0-4b. Construct an object or device to solve a problem or meet a need. GLO: C3
1-0-4d. Identify and make improvements to an object or device with respect to pre-determined criteria. GLO: C3
1-0-7b. Propose a solution to the initial problem. GLO: C3
1-0-7c. Identify new problems that arise. GLO: C3

TEACHER NOTES

SUGGESTIONS FOR ASSESSMENT

Depending on the type of community, different environments as sources for food can be highlighted, e.g., farming, fishing, and hunting locales. Students in urban locales can discuss the role of the supermarket in providing a link between the farmer and the shopper.

The materials made available to students can help define the parameters of this learning experience. Part of the criteria could be the use of a specific set or quantity of materials. This can make classroom management of materials easier and limit decisions that students are required to make. For some students at this level, an unlimited choice of materials is overwhelming.

Teachers may have students do all of the planning for the environmental dioramas or models at school and then have students do their construction at home. Upon completion, the projects could be presented to the class.

The criteria for evaluating the final design product must be developed with the students. The science-related criteria (e.g., meeting all of the animal's basic needs) will be provided by the teacher, but the majority of the other criteria should be identified by the students.

Observation Checklist: Designing an Environment

During the process of designing a representation of an environment look for evidence of the following:















- takes part in brainstorming solutions
- helps to create a plan
- helps to develop criteria
- uses a variety of resources to gather information
- constructs the representation
- tests the representation with the criteria established
- explains the design to the class

Group Assessment: Designing an Environment

Create a list of questions with icons, such as the ones below. Have each student assess her/his group's work. (Teachers may choose to read these items to students)

How did we work as a group?

Colour the face that shows how you feel.

- | | | | |
|---|---|---|---|
| We worked cooperatively. |  |  |  |
| We shared materials and ideas. |  |  |  |
| Everyone did his/her share of the work. |  |  |  |
| We took turns. |  |  |  |
| We listened to each other. |  |  |  |

PRESCRIBED LEARNING OUTCOMES	SUGGESTIONS FOR INSTRUCTION
<p><i>Students will...</i></p>	
<p>1-1-12 Identify hobbies and jobs that require knowledge of the needs of living things.</p> <p><i>Examples: gardeners, nurses, zookeepers...</i></p> <p>GLO: B4, B5</p>	<p>➤ Field Trip</p> <p>Take students on field trips to places such as a market garden, a veterinary clinic, a hospital, or a zoo. Have students look for examples of how people in that environment use their knowledge of the needs of living things to care for the plants, animals, or people in their charge (see Field Trips, <i>ELA, Grade 1</i>, p. 166).</p>
<p>1-0-2a. Access information using a variety of sources. <i>Examples: picture and concept books, people, excursions, camps, CD-ROMs...</i> (ELA 3.2.2, Math SP-II.1.1, TFS 2.1.1) GLO: C6</p>	<p>➤ Guest Presenter</p> <p>Invite students’ parents to talk about jobs or hobbies related to living things. Parents are a valuable resource and most parents are willing to share their knowledge with students.</p>
<p>1-1-13 Develop, implement, and evaluate personal and group action plans that contribute to a healthy environment for themselves and for other living things.</p> <p><i>Examples: wash hands before eating, reduce amount of waste produced by the class...</i></p> <p>GLO: B3, B5, C4, C7</p>	<p>➤ What Can I Do? Individual Weekly Planner</p> <p>As a class, brainstorm actions that students can do individually, each day, throughout the coming week to help themselves and other living things stay healthy. Record their actions on a daily plan using words and/or pictures. Plans could include the following ideas:</p> <ul style="list-style-type: none"> • not littering when travelling to and from school (or taking one day to pick up the litter they encounter) • selecting healthy snacks • bringing a lunch packaged in reusable materials
<p>1-0-3a. Brainstorm, with the class, possible solutions to a practical problem, and reach consensus on a solution to implement. (ELA 1.1.3, 3.1.3) GLO: C3, C7</p> <p>1-0-3b. Create, with the class, a plan to solve a problem or meet a need. Include: identify simple steps to follow. (ELA 1.2.3) GLO: C3, C7</p> <p>1-0-9a. Willingly consider other people’s views. GLO: C5, C7</p>	<p>➤ What Can We Do? Class Project</p> <p>As a class, develop and implement a project that would help students and other living things stay healthy (link to 1.12: Guest Presenter for a health perspective). Projects could include the following ideas:</p> <ul style="list-style-type: none"> • reducing the amount of classroom waste produced • cleaning up a local playground, park, or other area of the community
<p>1-1-14 Show respect for living things in their immediate environment.</p> <p><i>Examples: handling the class gerbil with care...</i></p> <p>GLO: B5</p>	<p>➤ Pet Rules!</p> <p>Develop, with the class, a set of rules for handling the classroom or school pet. Discuss the importance of each rule (link to 1.06: Pet Observations). Have students make posters to illustrate the rules. Post the rules near the pet.</p>

TEACHER NOTES	SUGGESTIONS FOR ASSESSMENT
<p>Note: parents refers to parents or guardians.</p>	
<p>Students at this level may not be familiar with the effects of their actions on the environment, themselves, and on other living things. It is important to limit the scope of the action plans to things that are within the realm of possibility for them.</p>	
<p>This attitudinal outcome can be addressed throughout this cluster with teachers modelling respectful behaviour towards living things and expecting this of students.</p>	

PRESCRIBED LEARNING OUTCOMES

Students will...

1-1-15 Recognize that some information they receive about living things is not scientific in nature.
Examples: movie animals talking, Jack’s beanstalk growing to the sky...
 GLO: A1, C5, C8

1-0-2b. Recognize when information answers the questions asked.
 (ELA 3.2.3, 3.2.5)
 GLO: C6, C8

1-0-7d. Connect new experiences and information with prior knowledge.
 (ELA 1.2.1)
 GLO: A2

1-0-7e. Describe, in a variety of ways, what was done and what was observed.
Examples: concrete materials, drawings, oral language...
 (ELA 4.1.2, 4.1.3) GLO: C6

SUGGESTIONS FOR INSTRUCTION

➤ **Fact or Fiction**

Read some traditional folk tales such as *The Three Little Pigs*, *Little Red Riding Hood*, or *Jack and the Beanstalk*. Have students list information from the story they believe is not factual, based on their experiences and knowledge of living things. For any areas they are unsure of, students should check the information in a non-fiction resource.

Example: *The Three Little Pigs:*

- Pigs do not build homes.
- Pigs cannot talk.
- Wolves cannot talk.
- Pigs do not cook supper.

➤ **Partner Reading**

Have partners read other fictional stories about living things and make lists of things in the stories that are science facts. Use a Sharing Circle to have students share science facts they have discovered and explain how these may have added to the story.

TEACHER NOTES

SUGGESTIONS FOR ASSESSMENT

It is important for students to begin developing the ability to discern fact from fiction. This should not lessen their enjoyment of fictional literature, movies, etc., but should ensure that misconceptions are avoided whenever possible.

NOTES

Grade 1

Cluster 2: The Senses

Overview

Our awareness of the environment and the many materials that are found within it is based on our sensory experiences.

Through our senses, we can detect items that may be good to eat, pose danger, or be useful. Our senses are immediate and automatic. But the ability to use our senses safely and effectively involves focus, discernment, awareness, and judgement. In this cluster, students learn more about what the senses are, how they operate, and how they must be protected. Students also refine their observation skills. These skills are critical to science (see *Grade 1, Cluster 3: Characteristics of Objects and Materials*) and can be applied to other subject areas.

PRESCRIBED LEARNING OUTCOMES

SUGGESTIONS FOR INSTRUCTION

Students will...

1-2-01 Use appropriate vocabulary related to their investigations of the senses.
 Include: senses, sight, smell, hearing, taste, touch, eye, nose, ear, tongue, skin, eyelash, eyebrow, eyelid, nostril, cartilage, nose hair, as well as descriptive words related to shape, colour, lustre, wetness, temperature, taste, odour, size, texture, pitch.
 GLO: C6, D1, D3

- Introduce, explain, use, and reinforce vocabulary throughout the cluster.
- **Classroom Word List**
 Develop a class word list as the cluster progresses. Print the vocabulary words on cards and post them where they are easily visible. Encourage students to use this list as a reference throughout the cluster. Group and label terms according to sense categories.

1-2-02 Identify the five senses and describe the main body parts with which they are associated.
 Include: sight and eyes; smell and nose; hearing and ears; taste and tongue; touch and skin.
 GLO: D1

- **Activating the Senses**
 Ask students how they get information about the world around them. During the discussion, provide various sense stimulators (take the lid off a strong-smelling substance, turn on an audio tape of common sounds, utilize an overhead projector to show images, have students use touch to identify an object in a mystery box). Have students discuss what type of information they are able to obtain.

1-0-4g. Verbalize questions and ideas during classroom learning experiences. GLO: C6
1-0-5a. Observe using a combination of the senses. GLO: C2

- **Sense Clusters**
 Have students work in small groups to talk about and record ideas in a Sense Cluster graphic organizer. Provide each group with a picture rich in sensory information (a busy street scene, a circus, etc.). Have students imagine they are in the scene and provide a graphic organizer such as the one shown below, to describe what they can “observe” in the pictured scene. Students record ideas and share their Sense Cluster in a Sharing Circle. (See *ELA, Grade 1*, p. 88; and *ELA, Strategies*, p. 106.)
 Have students repeat the activity in a convenient and safe real-life location, e.g., playground at recess, school lunchroom, etc.

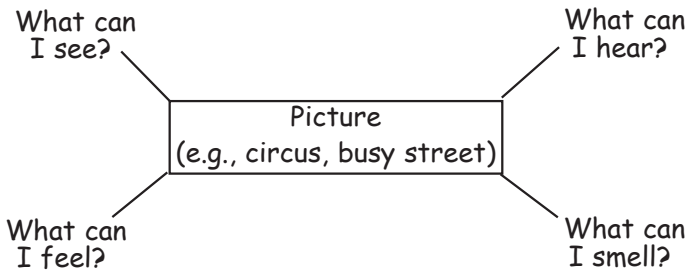

TEACHER NOTES

As the cluster on senses progresses, track and post students' questions in order to form the basis of further investigations.

SUGGESTIONS FOR ASSESSMENT

Caution: Care should be taken when dealing with the sense of taste. Students should be discouraged from tasting unknown substances. If tasting activities are used, they must be carefully controlled with attention paid to overall hygiene and possible allergies. Teachers may prefer to have students talk about the taste of familiar foods.

Paper and Pencil Task: The Senses

To assess understanding of the five senses and the body parts associated with each, provide students with a picture of a child. Have them label the location of each sense.

Match the sense to its body part.



Cut and paste.

sight	hearing	touch
smell	taste	

PRESCRIBED LEARNING OUTCOMES	SUGGESTIONS FOR INSTRUCTION
<p><i>Students will...</i></p>	
<p>1-2-03 Use their senses to sort and classify objects. <i>Examples: sort according to texture, sound, taste, or smell...</i> GLO: C2, D1, E1</p> <p>1-2-04 Identify and describe parts of the eye that help to protect it. Include: eyelash, eyebrow, eyelid. GLO: D1</p>	<p>➤ Using the Senses Set up four different stations with a collection of objects and materials in each. Have students use a different sense at each station to sort the collection. Example: touch. Have students cover their eyes and then sort the objects/materials by touch alone.</p> <p>➤ Observing Our Eyes Have students use small hand mirrors to examine their eyes. As a class, record questions that emerge about the function of different parts. Use these questions as the basis for the next investigation.</p>
<p>1-0-2a. Access information using a variety of sources. <i>Examples: picture and concept books, people, excursions, camps, CD-ROMs...</i> (ELA 3.2.2, Math SP-II.1.1, TFS 2.1.1) GLO: C6</p> <p>1-0-2b. Recognize when information answers the questions asked. (ELA 3.2.3, 3.2.5) GLO: C6, C8</p> <p>1-0-7e. Describe, in a variety of ways, what was done and what was observed. <i>Examples: concrete materials, drawings, oral language...</i> (ELA 4.1.2, 4.1.3) GLO: C6</p>	<p>➤ Eye Protection Have students use print and multi-media resources to locate information about the parts of the eye and the role each part plays in protecting it. Have students reflect on and discuss the text using the following questions:</p> <ul style="list-style-type: none"> • Why do you have eyelashes? Eyebrows? Eyelids? • The eye blinks every few seconds. Why does it do this?
	<p>➤ Picture Glossary: The Eyes Have It Have students draw a large human eye. Have them label the parts and then identify the protective functions of the eyelid, eyebrow, and eyelash (see Moline, 1995).</p> <p>➤ Art Extension The above learning experience can be extended into a creative art project by having students view various representations of the eye in art from different cultures (Egyptian, Haida, East-Indian, Sumerian, Greek, etc.) Have students use a variety of media to experiment with eye shapes through pattern and repetition.</p> <div data-bbox="649 1444 1416 1801" data-label="Image"> <p>The image is a collage of artistic representations of eyes and faces from various cultures. On the left is a detailed drawing of an Egyptian pharaoh's face with a headdress. In the center is a stylized, abstract eye with intricate patterns, resembling a Haida mask. To the right is a profile of a Greek head with a helmet. Below these are several other stylized eyes and faces, including one with a large, expressive eye and another with a more traditional, serene expression.</p> </div>

TEACHER NOTES

Hint: When having students cover their eyes for different activities, use an old, inexpensive pair of children's sunglasses. Cover the lenses with opaque tape (book binding, masking, duct, etc.). These work well and are easy to use.

The **eyelashes** protect the eye from dust and dirt. The **eyebrow** keeps perspiration from entering the eye. The **eyelid** protects the eye from light, retains moisture, and keeps objects out of the eye.

SUGGESTIONS FOR ASSESSMENT

Checklist of Observation Skills: Using the Senses

1. The student used the following senses for sorting:
 - sight
 - hearing
 - touch
 - smell
2. The student used the following characteristics for sorting:
 - colour
 - texture
 - shape
 - size
 - odour
 - other
3. The student was able to:
 - sort the objects/materials at each centre
 - explain the reason/rule for the sorting
 - identify the sense used for the sorting
4. The student
 - meets the learning outcome
 - requires additional practice/instruction

Paper and Pencil Task: Parts of the Eye

Tell students: Draw a picture of your eye. Label its parts. Use words from the word list.

Look for

- eyebrow
- eyelash
- eyelid
- other

PRESCRIBED LEARNING OUTCOMES

SUGGESTIONS FOR INSTRUCTION

Students will...

1-2-05 Recognize that their fingertips are especially sensitive to touch.
GLO: D1

1-0-4a. Follow simple directions while undertaking explorations. GLO: C2
1-0-5a. Observe using a combination of the senses. GLO: C2
1-0-5e. Record observations using drawings and tally charts. (ELA 4.1.2., 4.2.5; Math SP-II.1.1) GLO: C2, C6

➤ **Investigating Sensitivity to Touch**

Plan and conduct an investigation with the class to determine qualitatively which area of the body is most sensitive to touch. Use a variety of materials such as sandpaper, fake fur, steel wool, wood, fabric, or metal. Have students, in turn, touch each item with different parts of their bodies and rank the body parts according to sensitivity to touch.

In order to obtain accurate results, have students touch the object only with the listed body part.

➤ **Braille**

Contact the Canadian National Institute for the Blind to obtain Braille books or cards. Teach students three letters and have them find the letters in their Braille book or on their card. Use the following question for discussion: Why are fingertips so important to people who are blind?

1-2-06 Identify the external part of the ear, and explore to determine its function.
GLO: D1

➤ **Ear Investigation**

Pose the following question to the students, or refer to this question on the class list if it has already been proposed:
How does the outer part of the ear (what you can see) help you to hear? Use an investigation such as the following to answer this question.

Testing Ear Shape

Play music. Have students cup their hand in front of their ear and listen to the sound. Then have them cup their hand behind their ear. Have students make a large ear shape out of paper. Use the paper ear to listen to the music.

Questions for Discussion

Ask students the following questions:

- What happened to the sound when you cupped your hand in front of your ear? behind your ear?
- Why do you think our ears are cup-shaped?
- Does the size of the outer ear affect the clarity of sound?

Extension: Look at the ear size and shape of various animals and discuss how these characteristics may aid hearing.

1-0-1a. Ask questions that lead to explorations of living things, objects, and events in the immediate environment. (ELA 3.1.2, 3.1.3)
GLO: A1, C2, C5
1-0-4a. Follow simple directions while undertaking explorations. GLO: C2
1-0-7a. Propose an answer to the initial question based on their observations. GLO: A1, A2, C2

TEACHER NOTES

Have students use Blackline Master 1: Scientific Inquiry Recording Sheet: Grades 1 and 2.

The outer or external part of the ear helps funnel sound to the inner parts (auditory canal, middle, and inner ear) where sound is eventually changed to nerve impulses. These impulses send a message to the brain. The brain interprets the information.

SUGGESTIONS FOR ASSESSMENT

Interview: Outcomes 1-2-02 to 1-2-06 The Senses, Part 1

Before the interview gather the following materials: pictures of the eye, ear, and nose; a picture that lends itself to a description using the senses such as a busy street, playground, zoo, etc.; and a box with an unknown object in it (select an object that students can identify using the senses such as a cinnamon stick or a piece of cedar).

- Can you name the five senses and tell me where they are found?

<input type="checkbox"/> sight and appropriate body part	<input type="checkbox"/> touch and appropriate body part
<input type="checkbox"/> taste and appropriate body part	<input type="checkbox"/> hearing and appropriate body part
<input type="checkbox"/> smell and appropriate body part	
- Look at this picture. Tell me about the picture using your five senses.

<input type="checkbox"/> describe sights	<input type="checkbox"/> describe textures
<input type="checkbox"/> describe tastes	<input type="checkbox"/> describe odours
<input type="checkbox"/> describe sounds	
- Look at the picture of the eye. Can you show me the parts that help protect the eye?

<input type="checkbox"/> eyebrow	<input type="checkbox"/> eyelid
<input type="checkbox"/> eyelash	<input type="checkbox"/> other

Part 2

- Look at the picture of the ear. How does the outer part of the ear help you to hear?

The student

- indicates that it catches or directs the sound

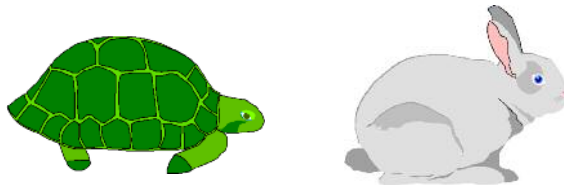

Look at the pictures of the two animals. Which animal do you think can hear better? Why?

The student

- chooses the rabbit
- discusses ear size and shape — the larger the ears, the better the hearing

PRESCRIBED LEARNING OUTCOMES

SUGGESTIONS FOR INSTRUCTION

Students will...

1-2-07 Use smell to identify familiar substances, following safe procedures.
Examples: vinegar, cinnamon, lemon, shampoo...
 GLO: C1, C2, D3

1-2-08 Identify parts of the nose and describe their functions.
 Include: nostril, cartilage, hairs.
 GLO: D1

1-0-2b. Recognize when information answers the questions asked. (ELA 3.2.3, 3.2.5) GLO: C6, C8

1-0-5e. Record observations using drawings and tally charts. (ELA 4.1.2., 4.2.5; Math SP-II.1.1) GLO: C2, C6

1-0-8a. Recognize that learning can come from careful observations and investigations. (ELA 3.3.4) GLO: A1, A2, C2

➤ **Identifying Odours**

Using empty film canisters, prepare samples of a variety of substances for students to identify through their sense of smell. Make holes in the lid of each canister, place substances inside, and number each one. Instruct students to identify each substance according to its odour. After all students have had an opportunity to identify the substances, discuss and chart the findings. Resolve differences by making additional observations.

➤ **Know the Nose**

Have students listen to, read, or view informational text that identifies parts of the nose and describes their functions. Discuss and chart the information.

<u>Part</u>	<u>Purpose</u>
nostril	takes in air
nose hairs	trap dust and dirt
cartilage	gives the nose shape

TEACHER NOTES

SUGGESTIONS FOR ASSESSMENT

Nostrils allow air into and out of the body. They also detect smell. **Cartilage** is a flexible type of bone that gives the nose its shape. **Nose hairs** filter dust that enters the nose.

Caution: Teach students how to use their hands to waft odours toward their noses instead of smelling them with their nose in direct proximity to the substance. While smelling something directly may only be unpleasant at this level, it can be harmful when dealing with chemicals at higher grades. Students should learn the proper procedure early.

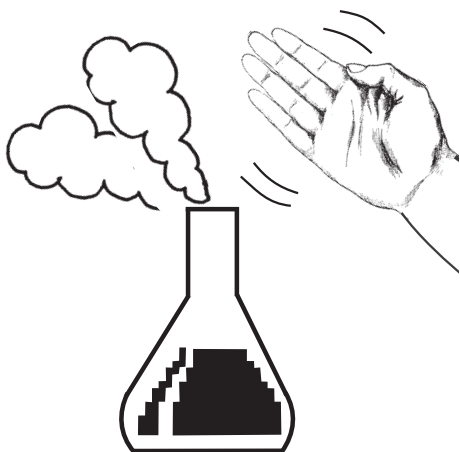

Performance Assessment: Identifying Odours

For this assessment provide students with four translucent film canisters. Put the following liquids into the canisters: vinegar, peppermint water, orange juice, and syrup. Label the canisters 1, 2, 3, and 4.

Student Directions: Your teacher filled these canisters with different liquids. He/she knows that one has vinegar, one has orange juice, one has syrup, and one has peppermint water. Help your teacher figure out which is which.

- Without touching the canisters, predict which liquid is in each canister.

Canister 1 _____

Canister 2 _____

Canister 3 _____

Canister 4 _____

- Now, use your senses to find out about the liquids.

Complete the sentences.

Canister 1 is _____ because _____.

Canister 2 is _____ because _____.

Canister 3 is _____ because _____.

Canister 4 is _____ because _____.

- What was the best sense to use to tell the liquids apart? Why?

Scoring Rubric

Scale	Task Performance
4	followed directions independently made predictions identified the liquids using senses, explanation clear
3	followed directions with limited assistance made predictions identified the liquids using senses, explanation clear
2	followed directions with limited assistance made predictions identified the liquids using senses, explanation unclear
1	required direct assistance made predictions identified liquids, explanation missing

PRESCRIBED LEARNING OUTCOMES

SUGGESTIONS FOR INSTRUCTION

Students will...

1-2-09 Identify parts of the body that are involved directly and indirectly in tasting.
 Include: the tongue is involved directly, the nose is involved indirectly.
 GLO: D1

1-0-7d. Connect new experiences and information with prior knowledge. (ELA 1.2.1) GLO: A2
1-0-8a. Recognize that learning can come from careful observations and investigations. (ELA 3.3.4) GLO: A1, A2, C2

1-2-10 Identify objects and procedures that protect the body and preserve each of the senses in explorations and in daily life.
Examples: sunglasses and safety goggles for eyes, gloves and tongs for hands, plugs for ears, washing hands regularly to avoid getting a cold or pinkeye...
 GLO: B3, C1

1-0-2a. Access information using a variety of sources. *Examples: picture and concept books, people, excursions, camps, CD-ROMs...* (ELA 3.2.2, Math SP-II.1.1, TFS 2.1.1) GLO: C6
1-0-4h. Follow given safety procedures and rules. GLO: C1
1-0-4i. Recognize safety symbols in their surroundings. GLO: C1

➤ **Tasty Words**

With students, brainstorm and list words to describe taste. Include sweet, sour, salty, hot (spicy), and bitter. Add these words to the class word list.

➤ **Investigating Taste and Smell**

Provide two small sections of apples for each student. Have each student eat one section and describe the taste. Have each student then smell a piece of onion, cover his or her nose, and eat the second piece of apple. Use the following questions for discussion:

- Was there a difference in the taste of the two apple pieces?
- Why did the second apple piece taste different from the first?
- What body parts are involved in tasting?

➤ **Science Journals**

Use the following prompt to focus students' science journal entries.

1. Two interesting facts I learned about my sense of taste are

_____.

_____.

2. One question I have is _____.

➤ **Safety Picture Splash**

Show students a page filled with pictures of a variety of objects used to protect the senses. Have students work in small groups to link objects together. Use a Sharing Circle for students to discuss reasons for the links they made. (See *ELA, Strategies*, p 106; and *Success For All Learners*, p. 29.)

➤ **Interviews: Protecting the Senses**

With the students, develop interview questions they can ask parents, relatives, or neighbours to find out how people protect their senses when they are at work and at play. Have students share their findings. Develop a class list of protective devices and how they protect the senses.

TEACHER NOTES

SUGGESTIONS FOR ASSESSMENT

Science catalogues are good sources for pictures of safety equipment.

PRESCRIBED LEARNING OUTCOMES	SUGGESTIONS FOR INSTRUCTION
<p><i>Students will...</i></p>	
<p>1-2-11 Explore to determine ways that the appearance, texture, sound, smell, and taste of objects can be altered.</p> <p><i>Examples: sanding, cooking, painting, tuning instruments, shaping clay...</i></p> <p>GLO: D3, E3</p>	<p>➤ Safety Posters: Be Sensible About Your Senses</p> <p>Have students design and make safety posters to encourage others to protect their senses. Each poster should feature one safety device.</p> <p>➤ Changes</p> <p>Undertake a variety of activities to facilitate students’ explorations of different ways that the appearance, texture, sound, smell, and taste of objects can be altered. Consider the activities below and discuss the changes with students:</p> <ul style="list-style-type: none"> • making popcorn • painting a piece of wood • modelling and texturing clay • making dried apple-head faces or dolls • drying meat <p>➤ Math Connection</p> <p>Have students measure, compare, and explain their observations before and after cooking activities. For example, how much did the popcorn weigh before being popped? How much more room did it need (volume)? What was the height of the highest pop?</p>
<p>1-0-5b. Use, with guidance, appropriate materials and tools to measure and construct.</p> <p><i>Examples: use paper clips to measure the width of a desk...</i> (Math SS-IV.1.1) GLO: C2, C3, C5</p> <p>1-0-5c. Estimate and measure the passage of time using non-standard units, and compare the duration of activities. (Math SS-VI.1.1) GLO: C2, C3, C5</p> <p>1-0-9c. Express enjoyment of science-related classroom activities. GLO: C5</p>	
<p>1-2-12 Describe ways in which the senses can both protect and mislead.</p> <p><i>Examples: seeing enables us to avoid obstacles, smell of smoke tells us something is burning, smell is not reliable when we have a cold, skin may not immediately tell us when we are getting sunburned or frostbitten...</i></p> <p>GLO: B3, C1, D1</p>	<p>➤ Safety Scenarios</p> <p>Provide picture scenarios illustrating how our senses can alert us to danger. Include both sense-based observations and warning devices that utilize the senses. Have students work in small groups to discuss one scenario and present it to the class. After each presentation have students discuss how information from our senses can help to protect us and how particular safety devices work with our senses to keep us safe. Examples of scenarios include:</p> <ul style="list-style-type: none"> • sirens, fire alarms, and smoke detector buzzers • flashing lights • smell of burning food • smell of spoiled food
<p>1-0-4i. Recognize safety symbols in their surroundings. GLO: C1</p>	
	<p>➤ Role Play: Misleading Senses</p> <p>Provide simple situations in which human senses may provide misleading or inadequate information resulting in harmful or dangerous experiences. Environmental hazards, such as sunburn or frostbite, are good examples. Have students work in groups to role-play and rehearse each scenario, including the preventative measures that should be taken.</p>

TEACHER NOTES

SUGGESTIONS FOR ASSESSMENT

--

Paper and Pencil Task: Safety

Tell students: Choose one of the senses. Show four ways that you can protect the sense you have chosen. Use pictures and words.

My sense is _____	
Four ways to protect your _____ are:	

PRESCRIBED LEARNING OUTCOMES	SUGGESTIONS FOR INSTRUCTION
<p><i>Students will...</i></p>	
<p>1-2-13 Recognize and appreciate that humans have different capabilities for sensing the environment and can use aids to assist them.</p> <p><i>Examples: glasses and guide dogs are used to assist people with visual impairment...</i></p> <p>GLO: B1, C5, E1</p> <p>1-2-14 Recognize and appreciate that humans may have different interpretations of similar sensory observations.</p> <p><i>Examples: one student likes the taste of broccoli, another does not...</i></p> <p>GLO: C5, E1</p>	<p>➤ Investigation</p> <p>Have students develop questions about how the visually or hearing impaired use aids to assist them in daily life. The class can plan group investigations to find the answers to their questions. The findings of each group can be presented to the class. Some possible questions include the following:</p> <ul style="list-style-type: none"> • How does a person with a hearing impairment know when to get up in the morning (can't hear an alarm clock), or know when a fire alarm is going off? • How does a person with a visual impairment know when it is safe to cross a busy street? <p>➤ Personal Favourites</p> <p>Have students use words and pictures to illustrate their two favourite items or experiences for each sense, e.g., smell: cinnamon and pine trees; taste: pizza and chocolate cake; and sight: sunsets, forests, etc. In small groups, have students share their lists of favourites. Model recognition and appreciation of differences among students. Lead students in a discussion using the following types of questions:</p> <ul style="list-style-type: none"> • Why do people have different likes and dislikes when tasting foods? • Why do people have different likes and dislikes when listening to music? • Why do people have different likes and dislikes when touching different textures? • Why do people have different likes and dislikes when smelling different aromas? • Why do people have different likes and dislikes when seeing different sights?
<p>1-0-1a. Ask questions that lead to explorations of living things, objects, and events in the immediate environment. (ELA 3.1.2, 3.1.3) GLO: A1, C2, C5</p> <p>1-0-9a. Willingly consider other people's views. GLO: C5, C7</p>	
	<p>➤ Math Connection</p> <p>Have students develop survey questions, collect their data, and make graphs of their favourite things.</p>

TEACHER NOTES

SUGGESTIONS FOR ASSESSMENT

Self-Assessment:

Note: Teachers may choose to read these to students.
Answer Yes or No to questions 1–6.

- 1. Some people use aids to help them see or hear.
- 2. It is okay to make fun of people.
- 3. You should help others.
- 4. Everyone likes the same types of food.
- 5. You should make a person eat something he or she doesn't like.
- 6. Everyone likes the same smells.
- 7. What would you tell someone who is teasing a person with glasses? _____

PRESCRIBED LEARNING OUTCOMES
<i>Students will...</i>
<p>1-2-15 Give examples of how the senses are important in various activities, hobbies, and jobs.</p> <p><i>Examples: smell is important to a chef, sight is important to a baseball player...</i></p> <p>GLO: B4</p>
<p>1-0-4f. Work in cooperative partnerships and groups. (ELA 5.2.1) GLO: C7</p> <p>1-0-9b. Willingly observe, question, and explore. GLO: C5</p>

SUGGESTIONS FOR INSTRUCTION

➤ **Hobbies and Jobs**

Have students work with partners to brainstorm and list hobbies and jobs in which the senses play important roles. Students should record their information on a chart and identify the senses that are most important for the activities or occupations involved. Encourage students to think about jobs that their parents have, hobbies that they have themselves, and common occupations in their community.

<u>Job</u>	<u>Activities</u>	<u>Senses Used</u>
chef	cooking and presenting food	smell, sight, touch

Link: *Native Studies: Early Years (K-4)*, p. 39, includes a learning experience addressing the importance of the senses in helping hunters and trappers ascertain their location and direction.

TEACHER NOTES

SUGGESTIONS FOR ASSESSMENT

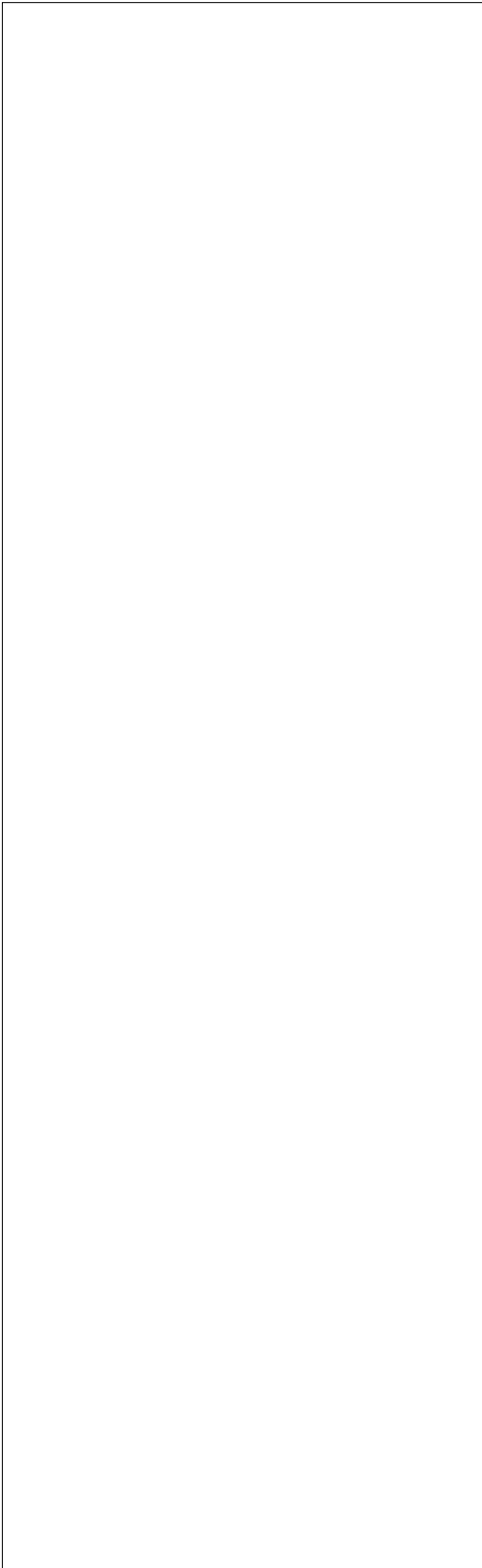

NOTES

Grade 1

Cluster 3: Characteristics of Objects and Materials

Overview

In Grade 1, students are introduced to the concept of materials by exploring various objects in their immediate surroundings. Through these observations, students distinguish between objects and materials, learning that objects are made from materials with specific characteristics. They are also able to describe these characteristics clearly and precisely. By making objects from various materials, they begin to understand the connection between a material's characteristics and the specific purpose(s) for which the material is used.

PRESCRIBED LEARNING OUTCOMES

Students will...

1-3-01 Use appropriate vocabulary related to their investigations of objects and materials.
 Include: characteristic, wood, metal, plastic, cloth, waterproof, absorbent, rigid, pliable, join, recycle.
 GLO: C6, D3

1-3-02 Explore and describe characteristics of materials using their sensory observations.
Examples: steel is hard, shiny, and cold, and makes a ringing noise when tapped...
 GLO: C2, D3

1-3-03 Distinguish between an object and the materials used to construct it.
Examples: chairs can be made of wood, metal, plastic, cloth, leather, wicker, or a combination of these materials...
 GLO: D3, E2

1-3-04 Identify materials that make up familiar objects.
Examples: a desk can be made up of wood, metal, and plastic...
 GLO: D3, E2

1-0-4e. Respond to the ideas and actions of others in building their own understandings. (ELA 1.1.2) GLO: C5, C7

1-0-4f. Work in cooperative partnerships and groups. (ELA 5.2.1) GLO: C7

1-0-4h. Follow given safety procedures and rules. GLO: C1

1-0-5a. Observe using a combination of the senses. GLO: C2

SUGGESTIONS FOR INSTRUCTION

- Introduce, explain, use, and reinforce vocabulary throughout the cluster.
- **Science Words**
 Develop a class list of science words as the unit of study progresses. Post the list where it is easily visible so students can use it as a reference.

- **Investigation**
 Part 1) Have students work in cooperative groups to describe a variety of materials, using sensory characteristics such as colour, shape, texture, and temperature (link to Cluster 2, The Senses). Have students record their observations on a chart.

<u>Material</u>	<u>Characteristic</u>
steel	smooth, shiny, "tings", grey, long and narrow
plastic	smooth, light, flexible, red

Once the chart is completed, have each group review the characteristics to identify those that would stay the same for every sample of that same material. Guide students to eliminate things relating to shape and colour.
 Part 2) Have students add a column to the original chart, indicating different objects that can contain or be made up of the materials they observed (e.g., plastic can be found in chairs, rulers, jackets, etc.).

- **Scavenger Hunt: Observing and Identifying Materials**
 Go on a scavenger hunt to find objects in the school that are made up of several different materials. Have students draw the object and label the parts according to the materials from which they are made. Examples:

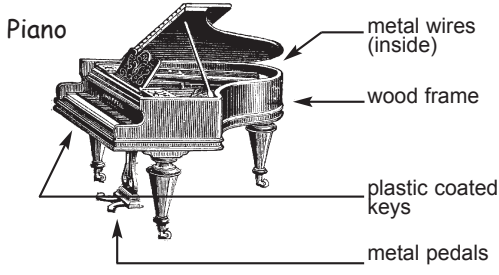

- **What's Inside?**
 Have students dissect discarded objects such as an old torn pair of ski pants, computer components, an old sneaker, a radio, etc. to discover what materials are inside. Have students glue each material onto heavy paper and label.

TEACHER NOTES



SUGGESTIONS FOR ASSESSMENT





















Wood, metal, plastic, cloth, and glass are examples of materials that are used to construct objects. The same type of object can be made from a variety of materials, e.g., a wooden baseball bat and an aluminum baseball bat. The characteristics of the materials determine their usefulness for a specific type of object, e.g., Why don't we see iron baseball bats?

When students are observing the characteristics of materials, try to provide samples of materials and not objects (e.g., a small piece of steel, not a steel nail). This will make it easier for the students to focus on the characteristics of the material and not on the characteristics of the object.

In **Scavenger Hunt**, students should use common terms to identify the materials found in different objects (e.g., plastic, metal, wood, etc.). The emphasis is on the recognition of different materials and not on the precise identification of all the materials involved.

Self-Assessment (Observation Skills): Investigation

(Teachers may choose to read the items to students.)

Colour the correct face.			
1. I used these senses to explore the materials:		2. I looked at:	
sight	 	colour	 
hearing	 	texture	 
taste	 	temperature	 
touch	 	shape	 
smell	 	sound	 

Paper and Pencil Task: Observing and Identifying Materials

To assess knowledge of materials that make up familiar objects, have students use words and/or pictures to explain what they have discovered about materials for building.

Look for

- evidence that the student knows the difference between an object and the materials of its construction
- identification of different materials

PRESCRIBED LEARNING OUTCOMES
<i>Students will...</i>
<p>1-3-05 Explore to identify characteristics of common materials. <i>Examples: waterproof/absorbent, rigid/pliable...</i> GLO: D3</p> <p>1-3-06 Give examples that show how the same material can serve a similar function in different objects. <i>Examples: in gloves and boots, rubber is used to keep out water...</i> GLO: D3, E1</p>
<p>1-0-3d. Identify materials to be used, and explain their choices. GLO: C2, C3, C4</p> <p>1-0-4a. Follow simple directions while undertaking explorations. GLO: C2</p> <p>1-0-6b. Compare data using quantitative terms, and ask questions about the data gathered. (Math SP-IV.1.1) GLO: A1, A2, C2, C5</p> <p>1-0-7a. Propose an answer to the initial question based on their observations. GLO: A1, A2, C2</p>

SUGGESTIONS FOR INSTRUCTION

➤ **Investigation: Keeping out the Rain**

Tell students: “Red Riding Hood needs to decide which jacket to wear to visit her grandmother today because it is raining outside.” Ask: “Which fabric keeps out water the best?” Use a variety of fabric samples such as silk, cotton, nylon, or latex rubber. Stretch each material over a clear plastic cup and hold the fabric in place with rubber bands.

Have students predict how many drops of water can be put on each material before the water drips through. Have them record their predictions on a chart.

Have students work in pairs and use eyedroppers to place one drop of water at a time on each fabric. Students must count the number of drops utilized before the water drips through the fabric. Students should count to twenty-five before adding the next drop. Have students record their findings on a chart.

Have students test all materials in the same manner.

<u>Fabric</u>	<u>Prediction</u>	<u>Actual Count</u>
cotton	3	4

Have students recommend which fabric would be best for making Red Riding Hood’s raincoat and why.

Math Link: Sequence the fabrics from least absorbent to most absorbent.

➤ **Characteristics of Materials**

Provide a variety of objects for students to sort according to other characteristics, such as pliability, weight, and strength. Discuss these characteristics and invite students to suggest objects that fit each category.

➤ **Where Would You Find It?**

From the **Investigation: Keeping out the Rain**, students discovered that rubber works well to keep out water. Have students identify other objects in which rubber is used to perform a similar function, e.g., rubber boots, rubber gloves, etc.

TEACHER NOTES

SUGGESTIONS FOR ASSESSMENT

At this point, students go beyond sensory observations of materials and begin to identify more in-depth characteristics.

Have students use Blackline Master 1: Scientific Inquiry Recording Sheet: Grades 1 and 2.

Observation Checklist: Keeping out the Rain

The student

- follows directions to conduct investigation
- makes predictions
- records predictions
- works cooperatively
- shares responsibilities with group member(s)
- collects data accurately
- records the collected data
- compares the data (the number of drops)
- arrives at an answer based on observations

Science Journal Entry: Keeping out the Rain

Ask students: What jacket would you tell Little Red Riding Hood to wear?

Explain your choice.

Look for

- reference to the investigation
- reference to some form of rubber, plastic, or latex

PRESCRIBED LEARNING OUTCOMES

Students will...

1-3-07 Test and evaluate the suitability of materials for a particular function.
Examples: test mitts made of different materials to evaluate their ability to keep hands warm and dry...
 GLO: C3, D3

1-0-1a. Ask questions that lead to explorations of living things, objects, and events in the immediate environment. (ELA 3.1.2, 3.1.3) GLO: A1, C2, C5
1-0-1b. Make predictions based on classroom experiences. GLO: A1, C2
1-0-5e. Record observations using drawings and tally charts. (ELA 4.1.2., 4.2.5; Math SP-II.1.1) GLO: C2, C6

1-3-08 Evaluate and describe the usefulness of common objects for a specific task.
Examples: compare usefulness of a toothbrush, hairbrush, toilet brush, or paintbrush for cleaning a sink...
 GLO: B1, C3, C4, D3

1-0-5c. Estimate and measure the passage of time using non-standard units, and compare the duration of activities. (Math SS-VI.1.1) GLO: C2, C3, C5
1-0-5d. Select an appropriate non-standard unit, and estimate and measure length. (Math SS-I.1.1) GLO: C2, C3, C5
1-0-7d. Connect new experiences and information with prior knowledge. (ELA 1.2.1) GLO: A2

SUGGESTIONS FOR INSTRUCTION

➤ **Investigating Materials for Warmth**

Setting the Context: Tell students that the mother of the “Three Little Kittens” is trying to decide what type of mittens to buy for all her children.

Ask the students what type of mittens they wear on a cold winter day. Challenge them to try and come up with a way to find out which mittens are warmest. An investigation such as the following should result:

Sample Investigation

Collect mittens made from a variety of materials, e.g., homemade, wool mittens; polyester, fibre-filled mittens; leather mittens; etc. Obtain four pairs in each category. Prepare a freezer bag of ice for each student. Before each trial, record class predictions about which material will prove the warmest. Have students who are wearing the same type of mittens hold the ice until their hands feel cold. Use a stopwatch to measure the time it takes for each student to feel cold. Record this information on a chart.

<u>Material</u>	<u>Prediction (What works best?)</u>	<u>Results</u>
wool	_____	_____
leather	_____	_____
polyester, fibre-fill	_____	_____

➤ **Investigation: The Best Tool for the Job**

- Have students work together to use a series of different brushes to scrub small sections of the classroom, hallway floor, desk, or table.
- Have students decide which brush is most suited to the task and have them justify their decision.
- Ask students to think of examples of other objects or tools that come in a variety of shapes and sizes. Discuss reasons why there are so many variations.

➤ **Guest Speaker**

Invite a painter, or another person who uses different-sized brushes in his/her work. Have the guest show students why different-sized brushes are important.

TEACHER NOTES

SUGGESTIONS FOR ASSESSMENT

If undertaking this unit during the winter, students may take turns wearing different mittens out for recess as part of this investigation. Ensure that students are respectful of each other's belongings throughout this activity and that they don't take risks during extreme cold weather.

Science Journal Entry: Materials for Warmth

Tell students: You need a new pair of mittens for winter. What kind will you buy? Explain why.

Look for

- reference to the investigation
- suitable selection

For **Investigation: The Best Tool for the Job**, cover an area with tempera paint or a similar substance that cleans easily with soap and water in order to provide a substance for scrubbing.

Paper and Pencil Task: The Best Tool for the Job

Match the brush to the place where it is used.

- | | |
|-------------|----------------|
| toothbrush | hair |
| scrub brush | painting easel |
| hairbrush | a mouth |
| paintbrush | a floor |

PRESCRIBED LEARNING OUTCOMES
<i>Students will...</i>
<p>1-3-09 Describe ways that materials can be joined.</p> <p><i>Examples: gluing, stapling, taping, interlocking, buttoning...</i></p> <p>GLO: C3, D3</p>
<p>1-0-4f. Work in cooperative partnerships and groups. (ELA 5.2.1) GLO: C7</p> <p>1-0-6a. Construct, with guidance, concrete-object graphs and pictographs using 1:1 correspondence. (Math SP-III.2.1) GLO: C2, C6</p> <p>1-0-7e. Describe, in a variety of ways, what was done and what was observed. <i>Examples: concrete materials, drawings, oral language...</i> (ELA 4.1.2, 4.1.3) GLO: C6</p>
<p>1-3-10 Use the design process to construct a useful object by selecting, combining, joining, and shaping materials.</p> <p><i>Examples: pencil holder, crayon box, desk organizer...</i></p> <p>GLO: C3, D3</p>
<p>1-0-1c. Recognize a practical problem in a given context. GLO: C3</p> <p>1-0-3a. Brainstorm, with the class, possible solutions to a practical problem, and reach consensus on a solution to implement. (ELA 1.1.3, 3.1.3) GLO: C3, C7</p> <p>1-0-3b. Create, with the class, a plan to solve a problem or meet a need. Include: identify simple steps to follow. (ELA 1.2.3) GLO: C3, C7</p> <p style="text-align: right;">(continued)</p>

SUGGESTIONS FOR INSTRUCTION

➤ **Wearing Fasteners**

Ask students: “How many fasteners are you wearing today?”

Have students draw pictures of themselves fully dressed. Have them label all of the fasteners they are wearing, e.g., laces, buttons, snaps, Velcro, etc. Show students how to develop these drawings into pictographs. Interpret the pictographs in a variety of ways.

Divide students into groups. Students will create a group pictograph that shows the type and numbers of their fasteners based on the fasteners identified in their pictures.

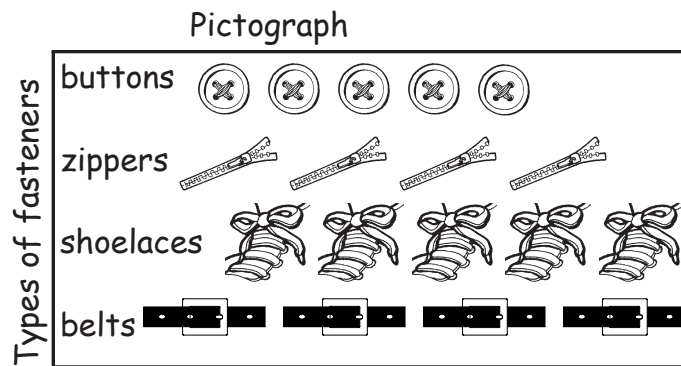

➤ **All Stuck Up**

Have students investigate to discover the best fastener for attaching buttons to a medium-weight paper in a button collage. Include different types of glue (white glue, glue stick); as well as tape; blunt plastic needles and thread; paper clips; etc. Ensure that students follow proper safety procedures.

➤ **Designing a Portable Supplies Container**

Say to students: “We have been talking about ways that materials can be joined. Today, we are going to use our knowledge of fasteners and joining materials to construct an object that is useful for carrying pencils, scissors, crayons, and glue. What could we make to carry these supplies to another room?”

- Have students follow the design process to construct and test their supplies container.
- Ensure that students follow safety procedures and rules for handling materials and tools.

(continued)

TEACHER NOTES

SUGGESTIONS FOR ASSESSMENT

A pictograph is a graph that uses symbols to represent data. (See “Teacher Information: Graphs,” in *Grades 5-8 Mathematics: A Foundation for Implementation.*)

Peer Assessment (Group Work): Wearing Fasteners

How Well Did We Work Together?

Yes or No? (Teachers may choose to read these items to the class.)

1. We shared the work. _____
2. We took turns. _____
3. We listened to each other. _____
4. We solved our own problems. _____
5. We worked until the job was completed. _____
6. We helped each other. _____

Design Process Checklist

The student

- understands the problem
- contributes to class brainstorming for solutions
- contributes to the creation of a plan
- contributes to the development of criteria
- identifies materials to be used
- explains the choice of materials
- constructs a useful object tests the object
- identifies and makes improvements to the object
- proposes a solution to the problem
- works cooperatively assumes group responsibilities
- presents his/her object to the group

PRESCRIBED LEARNING OUTCOMES
<i>Students will...</i>
<p>1-0-3c. Develop, as a class, limited criteria to evaluate an object or device based on its function. GLO: C3, C7</p> <p>1-0-3d. Identify materials to be used, and explain their choices. GLO: C2, C3, C4</p> <p>1-0-4b. Construct an object or device to solve a problem or meet a need. GLO: C3</p> <p>1-0-4c. Test, with guidance, an object or device with respect to pre-determined criteria. GLO: C3, C5</p> <p>1-0-4d. Identify and make improvements to an object or device with respect to pre-determined criteria. GLO: C3</p> <p>1-0-7b. Propose a solution to the initial problem. GLO: C3</p> <p>1-0-8b. Recognize that tools are developed in response to human needs. GLO: A3</p>
<p>1-3-11 Demonstrate ways to reduce, reuse, and recycle materials during classroom learning experiences.</p> <p>GLO: B5, D3</p>
<p>1-0-1c. Recognize a practical problem in a given context. GLO: C3</p> <p>1-0-3a. Brainstorm, with the class, possible solutions to a practical problem, and reach consensus on a solution to implement.(ELA 1.1.3, 3.1.3) GLO: C3, C7</p> <p>1-0-9d. Take the time to measure with care. GLO: C5</p>

SUGGESTIONS FOR INSTRUCTION

Criteria for the investigation could include the following:

- able to accommodate 10 pencils, 2 pairs of scissors, 3 packs of crayons, 1 container of glue
- able to be lifted (some type of handle)
- sturdy (doesn't fall apart)
- attractive

Have students use Blackline Master 3: Design Process Recording Sheet: Grades 1 and 2.

➤ **What's for Lunch?**

Have students check their own lunch kits (or a sample provided by the teacher) to see which materials can be reused or recycled. Have students suggest ways that non-recyclable materials could be reduced. Have students check their lunch kits on the following day. Ask students: Have you reduced the amount of non-recyclable materials in your lunch?

➤ **Tracking Classroom Waste**

For a week, have students keep track of how much waste is discarded in the classroom each day. Record data on a class chart.

<u>Materials</u>	<u>Monday</u>	<u>Tuesday</u>
paper	3 full garbage cans	2 1/2 garbage cans
plastic	5 drink/pudding cups	4 pudding cups
cans	3 pop cans	0 pop cans
other		

As a class, brainstorm ways to reduce classroom waste.

➤ **Reduce, Reuse, Recycle**

Have students use scraps of materials left from classroom learning experiences to create a collage or a sculpture. Materials could include scraps of construction paper, egg cartons, fabric scraps, wooden scraps, styrofoam, etc. Have students develop titles for their work, e.g., Robbie the Recycler, Garbage Helpers, etc. Look for examples of visual art to guide this learning experience.

TEACHER NOTES



SUGGESTIONS FOR ASSESSMENT

Peer Assessment: Design Presentation



Colour in the face that shows how you feel.

The speaker (name) _____

1. spoke clearly   

2. spoke so everyone could hear   

3. told all about his/her object   

4. kept the interest of the group   

I liked _____

Next time _____

It is important for teachers to note that it is not always possible for students to have control over or a say in what goes into their lunch. Children should not be made to feel embarrassed if the amount of non-recyclable materials has not changed.

Self-Reflection: Entire Cluster

Have students complete the self-reflection at the end of the learning experiences for this cluster.

Characteristics of Objects and Materials
Self-Reflection

1. Three things that I learned are:

1) _____

2) _____

3) _____

2. I liked _____

3. I didn't like _____

4. I would like to learn more about _____

NOTES

Grade 1

Cluster 4: Daily and Seasonal Changes

Overview

By observing their environment, students become aware of changes that can occur within it, such as changes in temperature, wind, and light, and in plant and animal life. Through observations and investigations, students learn that changes often occur in cycles, including the relatively short cycle of day and night and the longer cycle of the seasons. Recognizing these cyclical patterns prepares students to deal with daily and seasonal changes. Particular attention is given to studying ways in which humans are able to live comfortably throughout the seasons.

PRESCRIBED LEARNING OUTCOMES	SUGGESTIONS FOR INSTRUCTION
<p><i>Students will...</i></p>	
<p>1-4-01 Use appropriate vocabulary related to changes over time. Include: Sun, light, heat, day, day time, nighttime, morning, afternoon, days of the week, yesterday, today, tomorrow, seasons, shadow, characteristic, behaviour, living things, cycle. GLO: C6, D4, D6</p>	<p>➤ Introduce, explain, use, and reinforce vocabulary throughout the cluster.</p>
<p>1-4-02 Recognize that the Sun is a source of light and heat. GLO: D4, E4</p>	<p>➤ A Walk in the Sun Take the class for a walk on a warm, sunny day. Stop in the Sun and have the children describe how the Sun feels on their skin. Ask the following questions:</p> <ul style="list-style-type: none"> • How do you feel after a few minutes in the Sun? • Does your skin feel cool, warm, or hot? • Why does your skin feel warm in the Sun? • When you stay in the Sun for a long period of time on a hot summer day, what happens to your body? Why? • Will it feel the same if you go into the shade? Why or why not? <p>Once the students have predicted what will happen when they go into the shade, have them move into a shaded area and spend a few minutes there.</p>
<p>1-0-1b. Make predictions based on classroom experiences. GLO: A1, C2</p>	
<p>1-4-03 Recognize that a day is divided into day time and night time based on the presence or absence of sunlight. GLO: D6</p> <p>1-4-04 Sequence and record events and activities that occur over the course of a day, a week, or a year. GLO: C2</p>	<p>➤ Day or Night? Have students divide a page of paper in two. Students should draw things that they do during the day on one side and things that they do during the night on the other. Discuss what causes day and night (presence or absence of sunlight) and have students draw a Sun on the side with the daytime activities.</p> <p>➤ Joan’s Mixed-Up Day Provide students with a set of cards with pictures of a fictional character named Joan showing her activities over the course of one day. Tell them that Joan wants to record in her diary what she did but she has mixed up the cards. Have students work in cooperative groups to sequence the activities properly. Have them post their results on a diary sheet divided into morning, afternoon, and nighttime sections.</p>
<p>1-0-4f. Work in cooperative partnerships and groups. (ELA 5.2.1) GLO: C7</p> <p>1-0-7e. Describe, in a variety of ways, what was done and what was observed. <i>Examples: concrete materials, drawings, oral language...</i> (ELA 4.1.2, 4.1.3) GLO: C6</p>	

(continued)

TEACHER NOTES	SUGGESTIONS FOR ASSESSMENT
<p>Caution: Ensure that students wear hats and use sunscreen when going on walks or field trips.</p>	<p>Paper and Pencil Task: A Walk in the Sun</p> <p>Ask the student: How does the Sun help us? Draw a picture to show at least two different ways. Label your picture.</p> <p>Look for</p> <ul style="list-style-type: none"><input type="checkbox"/> provides heat<input type="checkbox"/> provides light
	<p>Interview: Day or Night?</p> <p>Before the interview, gather the following materials: pictures depicting night and day; pictures showing the activities of a child over the course of a day; days of the week printed on cards; a picture book that follows an animal or insect through a weekly pattern; pictures showing things that take a long time (tree through the seasons, baby to child) and those that take a short time (brushing teeth, skipping); and cards with the months of the year printed on them.</p> <ol style="list-style-type: none">1. Look at the pictures. Some show things that happen in the daytime and others show nighttime activities. Sort the cards into day and night. <p>The student</p> <ul style="list-style-type: none"><input type="checkbox"/> sorted correctly<input type="checkbox"/> explained reasons for placement

(continued)

PRESCRIBED LEARNING OUTCOMES
<p><i>Students will...</i></p>
<p>1-4-05 Recognize that shadows are caused by blocking light. GLO: D4, D6</p> <p>1-0-1b. Make predictions based on classroom experiences. GLO: A1, C2 1-0-7e. Describe, in a variety of ways, what was done and what was observed. <i>Examples: concrete materials, drawings, oral language...</i> (ELA 4.1.2, 4.1.3) GLO: C6 (continued)</p>

SUGGESTIONS FOR INSTRUCTION

- **By the Week**
Make an accordion book for each student. The booklet should have seven pages. Have students keep track of the things they do and the things that happen throughout the week. Have them share their books with the class. Math Link: Use the information for graphing.
- **By the Month**
Divide students into pairs. Have each pair take a month of the year and create a word splash of events, typical activities, words, etc., for that month.

October: Halloween, Thanksgiving, first snowfall, leaves change colours, pumpkins, jackets, Jack Frost, harvest
Have students create posters that illustrate their word splash. The posters can be used to sequence the months of the year. Discuss with the class the activities that occur each month.
- **Months of the Year: Wipe Out**
Have students play this game with a partner. Make a chart with the months of the year and their numeric equivalents (1-12). Using two dice, students take turns rolling the dice with their partner. If a 6 is rolled, June is crossed out; if a 2 is rolled, February is crossed out, and so on. Students may switch to using one die, as necessary (for the months January to June). The first player to wipe out the 12 months wins the game.
Use 12-sided dice if you have them. Students may also play **Wipe Out** with the days of the week and the numbers 1 to 7.
- **What's a Shadow?**
Have students experiment with flashlights and a stationary object such as a small teddy bear to observe how shadows are made, how they move, and the changes in size when the light source moves. Ensure students know that shadows are caused by an object blocking light. Extension: Trace the shadows made or have students develop theatrical performances utilizing a variety of shadow techniques.

(continued)

TEACHER NOTES

SUGGESTIONS FOR ASSESSMENT

2. Look at the pictures. These pictures show how “Mikhail” spent his day. Order the pictures so that they show his day from morning until night.

The student

- sequenced correctly explained reasons for the order

3. What are the names of the days of the week?

- Sunday Monday Tuesday
 Wednesday Thursday Friday
 Saturday names them in order

4. Look at the pictures. These are pictures showing what happened in the book that we read. Match the day of the week card with the picture that shows what happened on that day.

The student

- matched the cards with the picture independently
 required reading assistance but matched correctly
 was unable to match the card and the picture

5. What are the months of the year? How many can you name?

- January February March
 April May June
 July August September
 October November December
 named them in order named them out of sequence

6. Look at the pictures. Some of the pictures show something that would take a long time to happen and some show something that would take a short time to happen. Sort the pictures into long time and short time.

The student

- sorted correctly gave reasons for placement

PRESCRIBED LEARNING OUTCOMES
<i>Students will...</i>
<p>1-0-8a. Recognize that learning can come from careful observations and investigations. (ELA 3.3.4) GLO: A1, A2, C2</p> <p>1-0-9b. Willingly observe, question, and explore. GLO: C5</p>

SUGGESTIONS FOR INSTRUCTION

➤ **Predict-a-Shadow**

Have students discuss, as a class, the shapes of shadows observed outside and inside the classroom. Discuss what causes the shape of the shadow. The light source? The object? Or both? Use the overhead projector to demonstrate shadows. Have the students predict what shape they will see on the screen when a box, a glass, a book, a stapler, etc., is placed on the overhead in turn. Have students compare their predictions to the shape they actually see when the objects are placed on the overhead. Discuss why these shadows occur.

<p>1-4-06 Observe and describe how the Sun appears to change position over the course of a day.</p> <p><i>Examples: track the location of the Sun using shadows...</i></p> <p>GLO: C2, D6</p>
--

➤ **Sun Shadows**

Have students work in small groups of three to four to record shadows throughout the day. Each group will need a piece of white poster board and a stick or dowelling. Have students make a hole in the middle of a piece of white poster paper and place the paper on the ground outside where the Sun will shine on it. A stick or a dowel is placed through the hole in the poster paper. Throughout the day, students should colour the shadow cast by the stick, making sure to record the time beside the mark. They should also observe where the Sun is in relation to each shadow.

Students can compare the marks on their poster board with those of other groups.

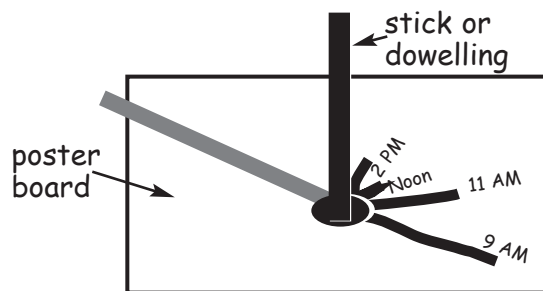

Use the following questions to reflect on the activity with the students:

- Do all groups' posters look the same? Why or why not?
- What made the shadows?
- What shape was the shadow?
- Why did the lengths of the shadow change?
- When did the longest shadow occur? The shortest?
- What other observations did you discover about the shadows made by the sticks?
- Do you think the same shadows will occur at the same time tomorrow? Why or why not?

TEACHER NOTES

SUGGESTIONS FOR ASSESSMENT

Have students use Blackline Master 1: Scientific Inquiry Recording Sheet: Grades 1 and 2.

Peer Assessment (Group Work): Sun Shadows

Answer Yes or No. (Teachers may choose to read these items to the class.)

Our group

followed directions _____

shared the work _____

took turns _____

listened to each other _____

recorded the shadow _____

recorded the time _____

helped each other _____

shared with other groups _____

One thing we did well was _____.

One thing we could do better next time is _____.

_____.

Observation Skills Checklist : Sun Shadows

The student

- follows simple directions to construct “sundial”
- works cooperatively
- records observations accurately
- labels observations accurately
- measures with care
- describes what was done and observed both orally and in pictures/words
- expresses enjoyment of the activity

PRESCRIBED LEARNING OUTCOMES
<i>Students will...</i>
<p>1-4-07 Record, describe, and compare changes in temperature at different times of the day. GLO: C2, D4, E3</p>
<p>1-0-5b. Use, with guidance, appropriate materials and tools to measure and construct. <i>Examples: use paper clips to measure the width of a desk...</i> (Math SS-IV.1.1) GLO: C2, C3, C5</p> <p>1-0-5e. Record observations using drawings and tally charts. (ELA 4.1.2., 4.2.5; Math SP-II.1.1) GLO: C2, C6</p> <p>1-0-6b. Compare data using quantitative terms, and ask questions about the data gathered. (Math SP-IV.1.1) GLO: A1, A2, C2, C5</p> <p>1-0-9d. Take the time to measure with care. GLO: C5</p>
<p>1-4-08 Investigate and describe changes that occur in characteristics and behaviours of living things throughout a day. <i>Examples: some flowers open in the morning, some animals are active at night...</i> GLO: D1, E3</p>
<p>1-0-7d. Connect new experiences and information with prior knowledge. (ELA 1.2.1) GLO: A2</p>

SUGGESTIONS FOR INSTRUCTION

➤ **How Hot Is It?**

Brainstorm with the class a list of words to describe temperature. Examples include hot, warm, cold, freezing, mild, etc. For a period of several days and at different times of the day, have students describe and record outdoor temperatures, using a class chart.

Monday

9 a.m.	12 p.m.	3 p.m.
chilly	warmer	warmest

Ask the students the following questions:

- Are the morning temperatures similar?
- When does the warmest temperature of a day usually occur? Explain your thinking.
- When are the coldest temperatures of a day recorded? Why?
- Why is it important to know when the warmest and coldest temperatures in a day usually occur?

➤ **Night and Day Animals**

Read a variety of books about animals to the class. Include animals that are active during the day (diurnal) as well as those that are active at night (nocturnal). Have students use the following chart to record information discovered.

Animal
Active day/night
What it eats
Where it goes when not active

As a class, select one animal that is active at night and one that is active during the day. As a group, write a story that follows the activities of each animal over a 24-hour period.

➤ **Plant Activities**

Divide the class into partners. Have partners find out about the activities of a plant throughout the course of a day. Provide books that describe plants such as sunflowers, morning glories, etc.

TEACHER NOTES

SUGGESTIONS FOR ASSESSMENT

Paper and Pencil Task: Night and Day Animals and Plants
Have students use words/pictures to answer the following questions.

Night and Day

1. What do animals do during a day? Label your drawings.

2. What do plants do during a day? Label your drawings.

PRESCRIBED LEARNING OUTCOMES
<i>Students will...</i>
<p>1-4-09 Compare characteristics of the four seasons. <i>Examples: length of day, type of precipitation, temperature...</i> GLO: E1, E3</p> <p>1-4-10 Describe how humans prepare for seasonal changes. <i>Examples: put up snow fences, take out winter clothes...</i> GLO: B1, C1</p>
<p>1-0-4e. Respond to the ideas and actions of others in building their own understandings. (ELA 1.1.2) GLO: C5, C7</p>
This area is intentionally left blank for additional notes or activities

SUGGESTIONS FOR INSTRUCTION

➤ **Knowing the Four Seasons**

Use a Think-Pair-Share (McTighe and Lyman, 1992) to determine what students know about the seasons. The following questions can help stimulate discussion:

- What are the four seasons?
- What type of weather do we have in each season?
- What activities do you do in each season?

Note: Think-Pair-Share is discussed in *ELA, Strategies*, p. 15.

➤ **Representing the Seasons**

Give each student a sheet of unlined paper. Tell students to fold the paper in half, and fold it in half again, labelling the sections spring, summer, fall, and winter. Ask them to colour a deciduous tree (e.g., crabapple) and a child in each box based on how the child would look in each of the seasons. Have students include the type of weather present in that season, what the child would wear and be doing. (Spring: buds on tree, rain falling, a child with rubber boots playing outside, etc.)

➤ **Preparing for the Seasons**

Working in pairs, have students draw and label the things that people do to prepare for each season.

Winter

- put up snow fence
- weather-proof house
- sharpen skates
- get out toboggan

Spring

- get out raincoats
- put in sump-pump
- wash windows

Summer

- buy sunscreen
- get out tent

Fall

- rake leaves
- clean eavestroughs

Have students share their projects with the class.

TEACHER NOTES

SUGGESTIONS FOR ASSESSMENT

Science Journal Entry: Seasons

Ask the student: What is your favourite season? Why is it your favourite? Tell how you get ready for this season.

Look for

- appropriate preparations for the season selected
- appropriate activities for the season selected

PRESCRIBED LEARNING OUTCOMES

SUGGESTIONS FOR INSTRUCTION

Students will...

1-4-11 Identify people who help us prepare for and deal with seasonal changes.
Examples: meteorologists, snow plough operators, reporters...
 GLO: B4

1-4-12 Identify features of buildings that help keep humans sheltered and comfortable throughout daily and seasonal cycles.
Examples: furnace, lights, air conditioners, fans, windows, blinds, walls, roof...
 GLO: B1

➤ **People Who Help**

Working in pairs, have students develop a mind map of people who help us prepare for or deal with seasonal changes.

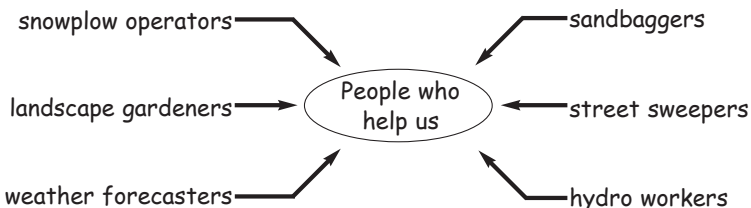

Have students choose one helper and draw that person preparing for seasonal change. Students may write sentences or label their drawings. Students may share their mind maps with the class and discuss what people do to help prepare and deal with seasonal changes.

1-0-4g. Verbalize questions and ideas during classroom learning experiences. GLO: C6

➤ **Keeping Us Comfortable**

Ask students the following question: To keep us comfortable, what features do our homes and other community buildings have that are similar to the school's? Different from the school's?

With the class, brainstorm a list of features or aspects of technology in buildings that keep people comfortable throughout daily and seasonal changes.

Have students use these words to write a poem or paragraph about: being comfortable, life without a furnace, left in the dark, etc.

Art Extension: using a variety of magazines, newspapers, and other print and visual media, have students make a collage of these building features.

1-4-13 Sort clothing to suit each season, and justify their decisions.
 GLO: B1, B3, C3, C4

➤ **What Am I Wearing?**

As children enter the classroom, tape a picture of a type of clothing on each of their backs. Use a variety of pictures that include items of clothing from each season. Students are to ask each other questions that can be answered by yes or no to discover the season in which they would wear "their" piece of clothing. As they find out what the items are, students should place themselves in groups according to the season in which the illustration on their backs belong.

1-0-6c. Place materials and objects in a sequence or in groups using a single, given attribute or a single, self-determined attribute. (Math SP-IV.2.1) GLO: C2, C3, C5

TEACHER NOTES

SUGGESTIONS FOR ASSESSMENT

Catalogues and sales flyers are good sources of pictures of different types of clothing. Saving catalogues or flyers all year will help ensure that pictures of clothing from the different seasons are available.

Performance Assessment: Seasonal Clothing

Before the assessment, gather articles of clothing related to the different seasons. Ask the students to sort the clothes according to the appropriate season and justify their placement.

Look for

- sorts the clothing into appropriate seasons
- justifies the placement of clothing

PRESCRIBED LEARNING OUTCOMES
<p><i>Students will...</i></p> <p>1-4-14 Describe safety precautions related to daily weather, the changing of the seasons, and weather extremes.</p> <p><i>Examples: wearing a raincoat if rain is expected, staying indoors during a blizzard, staying off thin ice in the spring and fall...</i></p> <p>GLO: B3, C1</p>
<p>1-0-4h. Follow given safety procedures and rules. GLO: C1</p> <p>1-0-4i. Recognize safety symbols in their surroundings. GLO: C1</p>
<p>1-4-15 Describe how humans are able to participate in non-seasonal activities.</p> <p><i>Examples: use indoor sport centres to swim in the winter and skate in the summer...</i></p> <p>GLO: B1, B3</p>
<p>1-0-4a. Follow simple directions while undertaking explorations. GLO: C2</p> <p>1-0-6c. Place materials and objects in a sequence or in groups using a single, given attribute or a single, self-determined attribute. (Math SP-IV.2.1) GLO: C2, C3, C5</p>

SUGGESTIONS FOR INSTRUCTION

➤ **Safe Practices**

As a class, create a mind map about safety precautions related to the weather or changing season that students should practise. Create categories such as the following to direct their thinking.

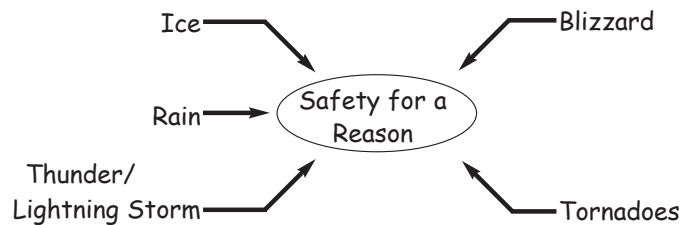

Have students add information about the type of warning, symbol, or announcement associated with each of the hazards.

➤ **Safety Posters**

Working alone or in pairs, have students design a safety poster to encourage other children to be safe during daily and seasonal weather changes. Put the poster up in the school and/or community to promote personal safety.

➤ **Staying Active All Year Long**

Have pairs of students develop lists of sports/activities associated with specific seasons. Have each student choose a sport/activity and draw and label it on an index card. Place labels of the four seasons on the bulletin board. Students must place their card with the season most commonly associated with that sport. Discuss the choices with the students.

Have students reclassify the pictures based on the existence of an indoor sports complex where one could swim, play hockey, play soccer, etc., all year round. Use the following questions for reflection:

- How have the indoor sports complexes changed our seasonal activities?
- Why are indoor sports complexes so important in Manitoba, as compared to places like California? (Teachers will need to choose geographic reference points with which their students are familiar.)

Math Link: Make a class graph of those who take swimming lessons during winter, play indoor soccer during the winter, skate/play hockey during the summer, etc.

TEACHER NOTES

SUGGESTIONS FOR ASSESSMENT

It is important to discuss why students should practise the safety rules. Every year, children and adults in Manitoba die from walking/skating on thin ice in the fall or spring and remaining in the open during a thunderstorm or blizzard.

PRESCRIBED LEARNING OUTCOMES
<i>Students will...</i>
<p>1-4-16 Identify physical and behavioural changes that occur seasonally among Manitoba plants and animals, and discuss possible reasons for these changes.</p> <p><i>Examples: thicker fur, migration, dormancy...</i></p> <p>GLO: D1, E3</p>
<p>1-0-1a. Ask questions that lead to explorations of living things, objects, and events in the immediate environment. (ELA 3.1.2, 3.1.3) GLO: A1, C2, C5</p> <p>1-0-2a. Access information using a variety of sources. <i>Examples: picture and concept books, people, excursions, camps, CD-ROMs...</i> (ELA 3.2.2, Math SP-II.1.1, TFS 2.1.1) GLO: C6</p> <p>1-0-2b. Recognize when information answers the questions asked. (ELA 3.2.3, 3.2.5) GLO: C6, C8</p>

SUGGESTIONS FOR INSTRUCTION

➤ **Manitoba Plants and Animals**

Ask the class the following focus question:

- What kinds of changes do you see happening to animals and plants as the seasons change?

Working in pairs, have students choose a Manitoba plant or animal for further research. Have students gather information from books, CD-ROMs, and videos. Students could fax, call, or e-mail wildlife and horticultural organizations to ask questions about changes that occur in the plant or animal during the different seasons. Have students present their findings in pictures or in words, using accordion books or quadoramas. Have students explain why the plant or animal responds to the seasonal changes as it does. For example, ducks migrate in the fall because there is no food for them when the water freezes. They lay their eggs in spring so the ducklings can grow strong enough to migrate in the fall.

Following the student presentations, use these questions to stimulate discussion:

- Why do animals migrate or hibernate in the fall or winter?
- What happens to most plants during the winter?
- Why is spring a good time of year for plants to bud? Baby animals to be born?

TEACHER NOTES

SUGGESTIONS FOR ASSESSMENT

Quadorama directions

Materials: four square pieces of paper (preferably manila tag)

Fold each square into quarters by folding on the diagonals. Cut one of the diagonals from the outside corner to the middle. Overlap the A and B. Glue them together.

Repeat for the remaining squares. When complete, glue the triangular pieces together to form a quadorama.

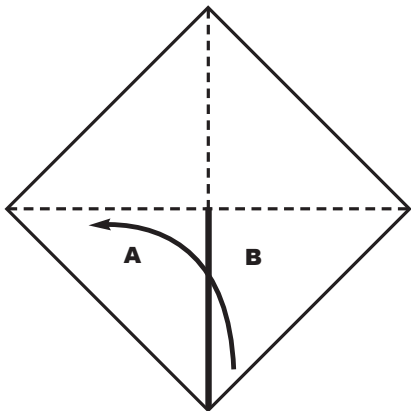
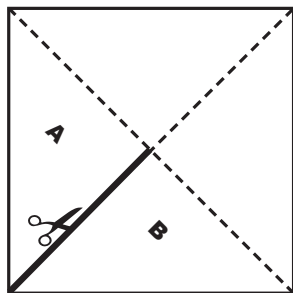
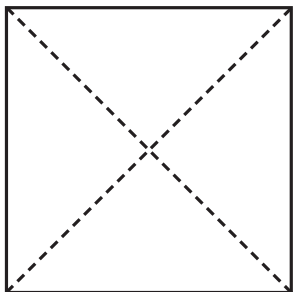

Learning Log Entry: Manitoba Plants and Animals

Three things I learned about how animals prepare for a change in seasons are:

PRESCRIBED LEARNING OUTCOMES
<i>Students will...</i>
<p>1-4-17 Use the design process to construct a device or structure that helps a Manitoba animal adjust to seasonal changes.</p> <p><i>Examples: winter birdfeeder, dog house, dog “booties” for winter...</i></p> <p>GLO: B5, C3</p>
<p>1-0-1c. Recognize a practical problem in a given context. GLO: C3</p> <p>1-0-2a. Access information using a variety of sources. <i>Examples: picture and concept books, people, excursions, camps, CD-ROMs...</i> (ELA 3.2.2, Math SP-II.1.1, TFS 2.1.1) GLO: C6</p> <p>1-0-3a. Brainstorm, with the class, possible solutions to a practical problem, and reach consensus on a solution to implement. (ELA 1.1.3, 3.1.3) GLO: C3, C7</p> <p>1-0-3b. Create, with the class, a plan to solve a problem or meet a need. Include: identify simple steps to follow. (ELA 1.2.3) GLO: C3, C7</p> <p>1-0-3c. Develop, as a class, limited criteria to evaluate an object or device based on its function. GLO: C3, C7</p> <p>1-0-3d. Identify materials to be used, and explain their choices. GLO: C2, C3, C4</p> <p>1-0-4b. Construct an object or device to solve a problem or meet a need. GLO: C3</p> <p>1-0-4c. Test, with guidance, an object or device with respect to pre-determined criteria. GLO: C3, C5</p> <p>1-0-4d. Identify and make improvements to an object or device with respect to pre-determined criteria. GLO: C3</p> <p>1-0-5b. Use, with guidance, appropriate materials and tools to measure and construct. <i>Examples: use paper clips to measure the width of a desk...</i> (Math SS-IV.1.1) GLO: C2, C3, C5</p> <p>1-0-7b. Propose a solution to the initial problem. GLO: C3</p> <p>1-0-7c. Identify new problems that arise. GLO: C3</p> <p>1-0-8b. Recognize that tools are developed in response to human needs. GLO: A3</p>

SUGGESTIONS FOR INSTRUCTION

➤ **Adjusting to Seasonal Change: Designing a Structure**

Say to students: We studied the seasons and the ways in which humans, animals, and plants prepare; we discovered that people have used technology in order to be more comfortable throughout the seasons. Unfortunately, animals cannot change their surroundings in the same way as humans can. We need to help them to survive. We are ready to design a device or structure that can help a Manitoba animal adjust to the seasonal changes.

The following questions can be used to help students identify a specific problem to address:

- How do humans help wild animals in the winter? In summer?
- How do we help our pets stay warm in the winter?

Working in pairs or small groups, have students research a variety of sources to help them decide what they will make to help a Manitoba animal.

Students should gather information by asking questions, using pictures, and their senses to develop a design that is appropriate for the animal they have chosen. Students will:

- ❶ design the device
- ❷ select and use appropriate tools and materials from the supplies provided by the teacher
- ❸ follow given safety procedures and rules
- ❹ share and explain their design to others

TEACHER NOTES

SUGGESTIONS FOR ASSESSMENT

Have students use Blackline Master 3: Design Process Recording Sheet: Grades 1 and 2.

Design Process Checklist

The student

- understands the problem
- contributes to class brainstorming for solutions
- contributes to the creation of a plan
- contributes to the development of limited criteria
- identifies materials to be used
- explains the choice of materials
- constructs a device or structure
- tests the object
- identifies and makes improvements to the object
- proposes a solution to the problem
- works cooperatively
- assumes group responsibilities
- presents his/her device or structure to the group

Self-Assessment of the Design Process

Answer Yes or No. (Teachers may choose to read these items to the class.)

1. I helped brainstorm a solution.
2. I helped develop a plan.
3. I helped develop criteria.
4. I made my device or structure.
5. I worked carefully and did my best.
6. I tested my device/structure.
7. I made changes/improvements to my device/structure.
8. I shared my device/structure with the class.

Next time _____
_____.

NOTES

Grade 2 Science

Grade 2

Cluster 1: Growth and Changes in Animals

Overview

In Grade 2, students focus on animals to build upon their knowledge of living things (see *Grade 1, Cluster 1: Characteristics and Needs of Living Things*). All animals grow and change from birth until adulthood. Because children are interested in the changes that take place over the lifetime of different animals, observing these changes becomes a powerful learning experience for them. In their explorations of growth, students compare their own growth with the growth patterns of various animals, and they learn about the conditions needed to support healthy development. Particular attention is given to the nutritional requirements of humans.

PRESCRIBED LEARNING OUTCOMES

SUGGESTIONS FOR INSTRUCTION

Students will...

2-1-01 Use appropriate vocabulary related to their investigations of growth and changes in animals.
 Include: food groups, *Canada's Food Guide to Healthy Eating*, offspring, adult, behaviour, life cycle, stage, life processes, as well as terms relating to life cycles studied.
 GLO: B3, C6, D1

- Introduce, explain, and reinforce vocabulary throughout the cluster.
- **Word Wall**
 Develop a classroom list of science words as the unit of study progresses. Record the words on cards and post on a Science Word Wall (Cunningham, 1991). Post the list where it is easily visible and encourage students to refer to it during journal or other writing.

2-1-02 Identify and describe constant and changing characteristics of humans as they grow and develop.
Examples: eye colour remains constant, height changes...
 GLO: D1, E3

2-1-03 Recognize that all humans do not grow and develop at the same rate.
 GLO: B3, D1, E1, E3

- **Comparing Myself**
 Have students bring photos of themselves as an infant, a toddler, and as a six- or seven-year-old. Have students work in pairs to complete the following chart. Post charts and have students present their information to the class.

How I Have Changed	
<u>Same</u>	<u>Different</u>
blue eyes	taller
brown hair	longer/more hair

2-0-1b. Make predictions based on observed patterns or on collected data. (ELA 1.1.1, 1.2.1) GLO: A1, C2

2-0-5b. Use, with guidance, tools to observe, measure, and construct. *Examples: ruler, metre stick, pan balance, magnifying glass, bathroom scale, thermometer...* (Math SS-VIII.1.2) GLO: C2, C3, C5

2-0-5d. Estimate and measure length using standard units. (Math SS-I.1.2) GLO: C2, C3, C5

2-0-6a. Construct and label concrete-object graphs, pictographs, and bar graphs using 1:1 correspondence. (Math SP-III.2.2) GLO: C2, C6

2-0-6b. Discuss data and generate new questions from displayed data. (Math SP IV.1.2) GLO: A1, A2, C2, C5

- Have students look at the baby pictures of their classmates. Ask students the following questions:
- How are all the babies the same?
 - How have all the babies changed?
- Picture Match: Put the baby pictures on the bulletin board and ask students to try and match each picture to a student in the classroom. Discuss how easy or difficult they found this task. Why?

- **Height Comparison**
 Have students work in pairs to measure the height of their partner and then record their information on self-stick notes. Place the self-stick notes on a pre-constructed class graph.
 Ask students these questions:
 - Why do you think that students of the same age are not the same height? (food, family characteristics)
 - At what age do you think we stop growing?
 Have students measure, record, and graph the heights of a class of students in a higher grade.

(continued)

TEACHER NOTES

SUGGESTIONS FOR ASSESSMENT

Teachers may want to have a set of classroom photos ready in order to facilitate student comparisons of contemporary and baby photographs.

PRESCRIBED LEARNING OUTCOMES	SUGGESTIONS FOR INSTRUCTION
<p><i>Students will...</i></p>	<p>Ask the following questions:</p> <ul style="list-style-type: none"> • What do you notice about the data collected? • How is this graph the same as our class height graph? • How is this graph different from our class height graph? • If we measured the heights of a class of high school students what do you think the graph would show? Explain your thinking.
<p>2-1-04 Recognize that food is a form of energy and that healthy eating is essential for growth and development. GLO: B3, D1, D4, E4</p>	<p>➤ Energy Analogy</p> <p>Give the students this analogy: Gas is to car as food is to _____. (animal)</p> <p>Ask students the following questions for reflection:</p> <ul style="list-style-type: none"> • What word do you think belongs in the blank? Why? • Why does a car need gas? • Why do animals need food? (to provide energy)
<p>2-0-4f. Work in a variety of cooperative partnerships and groups. (ELA 5.2.1) GLO: C7</p>	<p>➤ Healthy Bodies</p> <p>Have students think about what their bodies need to stay healthy and grow and have them share their ideas with a partner. Discuss the findings with the whole class.</p>
<p>2-1-05 Identify the four food groups of <i>Canada's Food Guide to Healthy Eating</i> and give examples of foods from each group. GLO: B3, E1</p>	<p>➤ Food Sort</p> <p>Provide students with pictures of a variety of foods representing the four food groups. Have them work in small groups to sort the pictures using their own classification system. Share their sorts with the class. Develop with the students a food group label for each sort. Clarify any misconceptions regarding food group placements at this time.</p>
<p>2-0-4g. Verbalize questions, ideas, and intentions during classroom activities. GLO: C6 2-0-6c. Place materials and objects in a sequence or in groups using one or two attributes, and describe the system used. (Math SP-III.0.2) GLO: C2, C3, C5</p>	<p>➤ Canada's Food Guide</p> <p>Distribute a copy of <i>Canada's Food Guide to Healthy Eating</i> to students. Ask these questions:</p> <ul style="list-style-type: none"> • What information is included in the <i>Food Guide</i>? • How does this information help you decide what to eat each day? • Why is important to eat something from each food group each day? • Where do things like potato chips, cake, and candy fit on the <i>Food Guide</i>?

(continued)

TEACHER NOTES

SUGGESTIONS FOR ASSESSMENT

Canada's Food Guide to Healthy Eating is distributed by Health Canada telephone (204) 983-2508, or (613) 954-5995. It is also available online at <www.hc-sc.gc.ca>.

Paper and Pencil Task: Food Sort

Student Directions: Provide pictures of food, labels from food, etc., for students. Have students sort the pictures into the correct food groups, using a chart like the one below.

Fruits & Vegetables	Breads & Cereals
Poultry, Meat, Fish, & Meat Substitutes	Dairy
Other	

PRESCRIBED LEARNING OUTCOMES	SUGGESTIONS FOR INSTRUCTION
<p><i>Students will...</i></p>	
<p>2-1-06 Plan a menu for one day based on the four food groups outlined in <i>Canada's Food Guide to Healthy Eating</i>. GLO: B3, C4, D1</p>	<p>➤ Meal Planning Use food pictures from the sorting activity, magazines, or student drawings. Have the students illustrate a nutritionally balanced breakfast, lunch, and supper. Display each meal on a paper plate. Ask students to explain why their meals are balanced.</p>
<p>2-0-7e. Describe, in a variety of ways, what was done and what was observed. <i>Examples: concrete materials, captioned drawings, oral language...</i> (ELA 4.1.2, 4.2.5) GLO: C6</p>	<p>➤ Fact Talk About Food Have students give a short talk about good nutrition and the four food groups from <i>Canada's Food Guide for Healthy Eating</i>. Provide opportunities for students to practise their talks with parents and peers before the presentation. (See <i>ELA, Grade 2</i>, p. 222.)</p>
	<p>➤ Math Connection Have students survey their classmates to find out what their favourite foods are and then graph the data collected.</p>
<p>2-1-07 Recognize that foods humans eat come from plants and animals, and classify foods accordingly. GLO: B1, B3</p>	<p>➤ Brainstorm Have students work with a partner to brainstorm a list of ten foods for each food group. Ask students: Where does the food you have listed come from before it gets to the grocery store? Through the discussion, have students recognize that food comes from plants and animals.</p>
<p>2-0-6c. Place materials and objects in a sequence or in groups using one or two attributes, and describe the system used. (Math SP-III.0.2) GLO: C2, C3, C5 2-0-9a. Willingly consider other people's views. GLO: C5, C7</p>	<p>➤ Sort and Classify Foods Have students sort their listed foods according to whether they come from plants or animals. Discuss with the class any foods they have had difficulty in placing.</p>
	<p>➤ Twenty Questions Place one food item or a replica or picture of the food item in an opaque bag. Have students apply the information learned about foods to ask questions that can be answered yes or no, and to try and discover the identity of the hidden food. Questioning continues until the food has been identified or twenty questions have been asked. The student who guesses correctly chooses the next food item.</p>

TEACHER NOTES

SUGGESTIONS FOR ASSESSMENT

Performance Task: Meal Planning

Scoring Rubric

- 4 Student’s work demonstrates a solid understanding of the four food groups and of a balanced meal. Three balanced meals are presented. Explanation is clear and complete.
- 3 Student’s work demonstrates a good understanding of the four food groups and of a balanced meal. Three meals are presented with two being balanced. Explanation is complete.
- 2 Student’s work demonstrates a basic understanding of the four food groups and of a balanced meal. Three meals are presented with one being balanced. Explanations may or may not be clear.
- 1 Student’s work demonstrates a limited understanding of the four food groups and of a balanced meal. At least two meals are presented. Meals shown are not balanced. Explanation is unclear or missing.

Student Journal Entry: Meal Planning

Tell students: Pat used these ingredients to make a pizza:

- whole wheat pizza crust
- cheese
- tomato sauce
- green peppers
- onions
- mushrooms
- ground meat

Is his pizza a healthy meal choice? (Yes.) Explain your thinking. Look for references to the four food groups.

Paper and Pencil Task: Sort and Classify Foods

Provide students with pictures of different types of food. Have students sort the foods according to whether they come from plants or animals. See Blackline Master 10: Food Sorting Cards. Student Directions: Cut out each picture. Glue each picture where it belongs.

Food from Animals	Food from Plants
-------------------	------------------

PRESCRIBED LEARNING OUTCOMES
<i>Students will...</i>
<p>2-1-08 Recognize that all animals can have offspring, and that offspring generally resemble their parents. GLO: D1, E1</p> <p>2-1-09 Compare the appearance of young and mature animals of the same type. GLO: D1, E1, E3</p>
<p>2-0-4a. Follow simple directions, and describe the purpose of steps followed. GLO: C2</p> <p>2-0-4f. Work in a variety of cooperative partnerships and groups. (ELA 5.2.1) GLO: C7</p> <p>2-0-5a. Make, with guidance, observations that are relevant to a specific question. GLO: A1, A2, C2</p> <p>2-0-5e. Record observations using written language, drawings, and, with guidance, charts. (ELA 4.1.2, 4.2.5) GLO: C2, C6</p>

SUGGESTIONS FOR INSTRUCTION

➤ **Matching Offspring**

Show the students a picture of a baby animal such as a calf, along with several different kinds of adult animals including the parents of the baby. Ask the following questions:

- Which adult is this animal’s parent?
- How do you know?

➤ **What’s My Name?**

Have students work in cooperative groups to fill in the chart with the names of the males, females, and babies of a variety of animals.

Male	Female	Baby
Rooster	Hen	Chick
Gander	Goose	Gosling
Buck	Doe	Fawn
Boar	Sow	Cub
Bull	Cow	Calf

Share group findings with the entire class.

➤ **Adult-Baby Comparison — Field Trip**

In the spring, have the class visit a local farm or zoo to observe baby animals and their parents. Have students record their observations on a chart such as the one below. Have students use the appropriate names for males, females, and babies as they observe and ask questions.

Animal	Things that are the same in the baby and parent	Things that are different in the baby and parent

Have students share their observations with the class.

TEACHER NOTES

See *Success For All Learners* and *Science Safety* for guidelines related to school trips. A field trip can provide the opportunity to address other outcomes in this cluster including 2-1-10, 2-1-11, 2-1-13, 2-1-16, 2-1-17.

Agriculture in the Classroom, telephone: (204) 487-4029, can provide ideas for field trips, guest speakers, and learning resources to support these outcomes. Contact your local Manitoba Agriculture office for additional information about resource materials and speakers.

SUGGESTIONS FOR ASSESSMENT

Group Assessment: What's My Name?

How Well Did We Work? Comments

We took turns. _____

Everyone participated. _____

We shared materials. _____

We listened to one another. _____

We encouraged one another. _____

We completed the work. _____

Paper and Pencil Task: Adult-Baby Comparison

Use a Venn diagram to compare similarities and differences between baby and adult of a given animal.

Example:

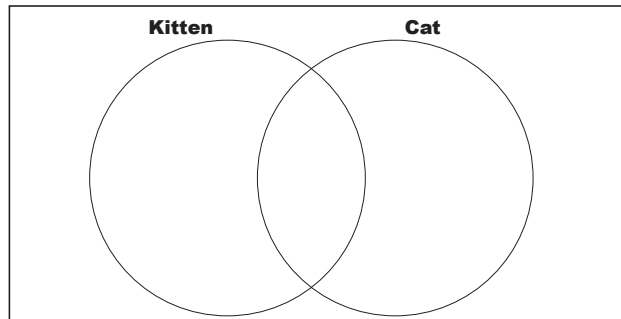

Provide the following list to be cut apart and pasted into the Venn diagram.

hairless	has fur	2 eyes
4 legs	drinks milk	eats solid food
has claws		

PRESCRIBED LEARNING OUTCOMES
<i>Students will...</i>
<p>2-1-10 Compare the length of time from birth to adulthood for humans and other animals. GLO: D1, E1</p> <p>2-1-11 Identify and describe constant and changing characteristics of an animal as it grows and develops. GLO: D1, E3</p>
<p>2-0-2a. Access information using a variety of sources. <i>Examples: elders, simple chapter books, concept books, CD-ROMs, Internet...</i> (ELA 1.1.2, 3.2.2 Math SP-II.1.2; TFS 2.1.1) GLO: C6</p> <p>2-0-5e. Record observations using written language, drawings, and, with guidance, charts. (ELA 4.1.2, 4.2.5) GLO: C2, C6</p> <p>2-0-7a. Propose an answer to the initial question based on their observations. (Math SP-IV.2.2) GLO: A1, A2, C2</p>

SUGGESTIONS FOR INSTRUCTION

➤ **Inquiry Chart**

Have the class use an Inquiry Chart (Hoffman, 1992) to research a specific animal. (See *ELA, Strategies*, p. 83.)

Inquiry Chart for _____			
Topic:	How do baby _____ look like their parents?	How do baby _____ look different from their parents?	How long does it take a baby _____ to become an adult?
What we know (as a class)			
Info. from books (group 1)			
Info. from videos (group 2)			
Info. from CD-ROMs (group 3)			
What we discovered (as a class)			

Have the class identify what they know about the first question. Divide the class into groups and provide each group with one or two reference sources such as books, videotapes, and CD-ROMs. Have the groups look at their resources to see if they contain answers to the first question. They record the information on a card such as the one below.

<p style="text-align: center;">Where did I (we) find the information I (we) need?</p> <p style="text-align: center;">What did the source(s) say?</p>
--

Cards can then be placed on the Inquiry Chart. Once all the information has been gathered, have the class summarize what was discovered. Follow the same process to complete the remaining questions.

Ask the class the following questions:

- How long do human babies need to be fed by their parents?
- When do humans become adults or become independent?
- How long do other animals take to become adults or become independent?
- How are human babies different from these animals?
- What characteristics usually stay the same in animals from birth to adulthood?

TEACHER NOTES

SUGGESTIONS FOR ASSESSMENT

Refer to Assessment opposite 2-1-12.

Science Journal Entry: Inquiry Chart

Have students answer the following questions in their science journals:

- How am I the same as my parent/guardian?
- How am I different from my parent/guardian?

Look for

- things that stay the same, such as: two eyes, two ears, two legs, two arms, etc.
- things that are different, such as: size, amount of hair, muscles, etc.

PRESCRIBED LEARNING OUTCOMES	SUGGESTIONS FOR INSTRUCTION								
<p><i>Students will...</i></p>									
<p>2-1-12 Describe and classify a wide range of animals according to various characteristics and behaviours.</p> <p><i>Examples: skin covering, where they live, food they eat, day or night activity, how they move...</i></p> <p>GLO: C2, D1, E1</p>	<p>➤ Animal Facts: Video Research</p> <p>Show students a video that features a variety of animals. Have students record answers to a predetermined question while watching the video. Examples:</p> <table border="0" data-bbox="673 478 1177 634"> <thead> <tr> <th colspan="2" data-bbox="673 478 1177 514">What do animals eat?</th> </tr> <tr> <th data-bbox="673 514 950 550"><u>Animal</u></th> <th data-bbox="950 514 1177 550"><u>What it eats</u></th> </tr> </thead> <tbody> <tr> <td data-bbox="673 550 950 588">robin</td> <td data-bbox="950 550 1177 588">worms</td> </tr> <tr> <td data-bbox="673 588 950 634">kangaroo</td> <td data-bbox="950 588 1177 634">plants</td> </tr> </tbody> </table>	What do animals eat?		<u>Animal</u>	<u>What it eats</u>	robin	worms	kangaroo	plants
What do animals eat?									
<u>Animal</u>	<u>What it eats</u>								
robin	worms								
kangaroo	plants								
<p>2-0-1a. Ask questions that lead to investigations of living things, objects, and events in the immediate environment. (ELA 1.2.4, 3.1.2, 3.1.3; Math SP-I.1.2) GLO: A1, C2, C5</p> <p>2-0-2a. Access information using a variety of sources. <i>Examples: elders, simple chapter books, concept books, CD-ROMs, Internet...</i> (ELA 1.1.2, 3.2.2 Math SP-II.1.2; TFS 2.1.1) GLO: C6</p>	<p>Provide information resources (pictures, videotapes, books) about other kinds of animals. Have students place these animals in groups, according to how they move.</p>								
	<p>➤ Role Play</p> <p>Have students role-play the movement of different animals. Examples: leap like a frog, hop like a kangaroo, waddle like a duck, lumber like an elephant, gallop like a horse, slither like a snake, crawl like a caterpillar . . . Ask students the following questions:</p> <ul style="list-style-type: none"> • How do these movements help the animals get food and find protection from their enemies? • What other animals hop, crawl, etc.? <p>Have students carry out similar activities describing and grouping animals according to other characteristics (e.g., skin covering).</p> <p>➤ Pattern Book</p> <p>Have students use a familiar pattern book to write their own book about how animals move.</p> <p>Example: Frog, frog, how do you move? I leap from the lily pads and swim in the water. Robin, robin how do you move? I fly to the ground on a rainy day to collect worms for my dinner.</p>								

TEACHER NOTES

SUGGESTIONS FOR ASSESSMENT

Student Interview: Animal Facts (2-1-10 to 2-1-12)

Before interviewing the student, prepare a set of cards (16). See Blackline Master 11: Animal Sorting Cards. Each card should have a picture of a different animal on it. Include mammals, birds, fish, reptiles, amphibians, and insects. (Students don't have to know these terms.)

Say to students:

1. I want you to sort the animal pictures in one way.
What is your sorting rule?
2. Can you sort the pictures in another way?
What is your rule?
3. Can you sort the pictures in a different way?
Record the sorting rules.
4. Pick one of the animals.
Tell me what you know about the animal.

Expected responses will depend on the animal chosen. Students should make reference to some of the following for both the sorting and the animal:

- living thing
- appearance (body parts)
- skin covering
- habitat
- foods they eat
- nocturnal/diurnal
- movement
- enemies
- life cycle
- names of male/female/baby
- protection (if known)

PRESCRIBED LEARNING OUTCOMES
<i>Students will...</i>
<p>2-1-13 Describe and compare ways in which different animals care for their offspring.</p> <p><i>Examples: Canada geese, bears, alligators, bees...</i></p> <p>GLO: D1, E1</p>
<p>2-0-4a. Follow simple directions, and describe the purpose of steps followed. GLO: C2</p> <p>2-0-4h. Follow given safety procedures and rules. GLO: C1</p>
<p>2-1-14 Describe changes in the appearance and activity of various animals as they go through a complete life cycle.</p> <p>Include: an insect, a bird, an amphibian.</p> <p>GLO: D1, E3</p> <p>2-1-15 Compare the life cycles of animals that have similar life cycles and those that have different life cycles.</p> <p><i>Examples: bee and butterfly, gerbil and butterfly...</i></p> <p>GLO: E1, E3</p>
<p>2-0-5a. Make, with guidance, observations that are relevant to a specific question. GLO: A1, A2, C2</p> <p>2-0-5b. Use, with guidance, tools to observe, measure, and construct. <i>Examples: ruler, metre stick, pan balance, magnifying glass, bathroom scale, thermometer...</i> (Math SS-VIII.1.2) GLO: C2, C3, C5</p>
(continued)

SUGGESTIONS FOR INSTRUCTION

➤ **Animal Comparison**

Have students work in small groups to compare the parent care provided by the following animals.

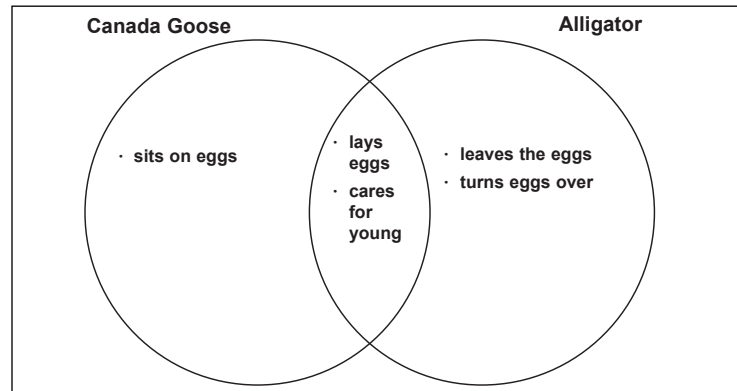

Phrases to use for the comparison

- lays eggs
- leaves the eggs
- sits on eggs
- cares for young
- turns eggs over
- teaches babies to swim
- cares for young until following spring
- both parents care for young

➤ **Mealworm Life Cycle**

Have students observe daily the changes in the mealworms. When the mealworms enter the pupa stage, have students observe the mealworms with a magnifying glass. Have them record the changes that they observe. Have students draw and label a Life Cycle Diagram for the mealworm.

➤ **Read Aloud and Discuss: Butterflies**

Read a science book about a butterfly’s life cycle. Identify the changes from egg to caterpillar to cocoon to butterfly. Focus the discussion on the following questions for reflection:

- Where did the caterpillar come from? (an egg)
- How does the caterpillar meet its own needs?
- What happens as the caterpillar changes?

(continued)

TEACHER NOTES

SUGGESTIONS FOR ASSESSMENT

Set up a life cycle that the students can actively observe during the course of this cluster. Mealworms can be purchased from most pet stores and the stages of their life cycle are easy to observe.

In the pupa stage of the mealworm's life, students can actually observe the changes that take place because mealworms do not spin a cocoon or chrysalis.

Other life cycle options include raising brine shrimp, hatching chicken eggs, raising painted butterflies, or collecting tadpoles and watching them turn into frogs.

Educators are allowed to collect tadpoles for use in the classroom. However, tadpoles/frogs should be returned to the location from which they were collected.

(continued)

PRESCRIBED LEARNING OUTCOMES
<i>Students will...</i>
<p>2-0-7d. Connect new experiences, ideas, and information with prior knowledge and experiences. (ELA 1.2.1, 2.1.2) GLO: A2</p> <p>2-0-7e. Describe, in a variety of ways, what was done and what was observed. <i>Examples: concrete materials, captioned drawings, oral language...</i> (ELA 4.1.2, 4.2.5) GLO: C6</p> <p>2-0-9c. Take the time to repeat a measurement or observation for greater precision or detail. GLO: C5</p>

SUGGESTIONS FOR INSTRUCTION

➤ **Life Cycle Diagram**

Model to show students how to draw a life cycle diagram based on the information gathered from the science book and the ideas discussed. If using the life cycle of an insect, ensure that students are familiar with the terms “larva” and “pupa.”

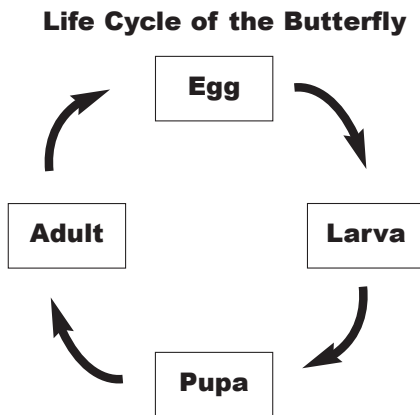

➤ **Researching Life Cycles**

Have students work in pairs to find information about the life cycle of an animal. Include different animals such as insects, birds, amphibians, reptiles, mammals, and fish. Have students represent their findings visually and share them with the class.

➤ **Gallery Walk**

Do a gallery walk to look at the visual representations of the different life cycles. Have students select two life cycles to compare and contrast by using the following headings. Students can fill in their list after viewing the representations.

The _____ Cycle and the _____ Cycle

Ways they are alike

Ways they are different

TEACHER NOTES

SUGGESTIONS FOR ASSESSMENT

Students should have opportunities to study diverse animals. Studying an insect, a bird, and an amphibian will ensure variation, but students do not need to be familiar with these animal classifications.

The Manitoba Fisheries Sustainable Development website provides teacher background information and instructional suggestions related to fish lifecycles .

Science Journal Entry: Life Cycles

Student Directions: Choose either a bird, a frog, or a butterfly. Tell about its life cycle. Include a labelled diagram. When your entry is complete use the following checklist to rate your work.

Science Journal Self-Assessment

- My work (diagrams/writing) is neatly done.
- My diagram is labelled.
- I have used science words.
- My entry has all the information asked for in the question.

PRESCRIBED LEARNING OUTCOMES
<i>Students will...</i>
<p>2-1-16 Observe and describe an animal’s life processes. Include: eating habits, movement, rest patterns, breathing. GLO: E3</p> <p>2-1-17 Identify and describe ways in which humans help other animals. <i>Examples: protecting endangered animals, feeding birds...</i> GLO: B1, B5</p>
<p>2-0-4h. Follow given safety procedures and rules. GLO: C1</p> <p>2-0-5a. Make, with guidance, observations that are relevant to a specific question. GLO: A1, A2, C2</p> <p>2-0-5c. Estimate and measure the passage of time related to minutes and hours. (Math SS-VI.1.2) GLO: C2, C3, C5</p> <p>2-0-5e. Record observations using written language, drawings, and, with guidance, charts. (ELA 4.1.2, 4.2.5) GLO: C2, C6</p> <p>2-0-8a. Recognize that learning can come from careful observations and investigations. (ELA 3.3.4) GLO: A1, A2, C2</p>

SUGGESTIONS FOR INSTRUCTION

➤ **Mealworm Observation**

Give each student a mealworm and a magnifying glass. Have students use as many of their senses as possible to observe the worms. Make labelled diagrams of their observations. Note: mealworms can be put in a sealable plastic bag if students are reluctant to touch them. Ask students the following questions:

- What do you notice about the mealworm’s body?
- How does the mealworm move?
- What does the mealworm eat?

➤ **Pet Observation**

Have students observe a classroom pet over the course of a day and record the animal’s activity. Example:

Herbie Hamster’s Day

9:00 am eating seeds
9:30 am sleeping
10:00 am playing on the wheel

Ask the students the following questions:

- Were there any changes in the pet’s breathing during the day?
- When was the pet most active?
- What do you think would be happening if a record were kept of the pet’s nighttime activity? Explain your thinking.

➤ **Helping Animals to Survive**

Use a Directed-Reading-Thinking activity (Stauffer, 1969; Santa 1988) using stories that focus on the ways in which humans help other animals to survive. (Note: the Directed Reading-Thinking activity is discussed in *ELA, Strategies*, pp. 120-122.)

➤ **Posters**

Have students make posters to encourage other students in the school to help animals, for example, feeding birds in winter or building nesting boxes.

TEACHER NOTES

SUGGESTIONS FOR ASSESSMENT

Refer to Appendix D for information on animals in the classroom. It is recommended that mammals be classroom visitors, rather than long-term pets.

Observation Checklist: Mealworm Observation

During the “mealworm” learning experiences, look for the following skills:

The student

- asks questions about mealworms
- follows rules regarding care of mealworms
- uses magnifying glass to observe mealworms
- makes relevant observations
- records observations using words and drawings
- demonstrates an interest in the mealworm learning experiences

NOTES

Grade 2

Cluster 2: Properties of Solids, Liquids, and Gases

Overview

When students examine materials in the world around them, they become aware of the similarities and differences in their characteristics, such as the ways materials look, feel, sound, or change. In Grade 2, students begin to develop an understanding of matter by investigating properties of solids and liquids. Gases are also introduced through an examination of the properties of air. Students investigate ways in which solids and liquids interact, and identify how the properties of solids and liquids determine their uses. Students observe how water can be made to change from one state to another and back again. Students also encounter changes of state in the study of the water cycle in *Grade 2, Cluster 4, Air and Water in the Environment*. Teachers are encouraged to help students make connections between these learning experiences.

PRESCRIBED LEARNING OUTCOMES	SUGGESTIONS FOR INSTRUCTION
<p><i>Students will...</i></p>	
<p>2-2-01 Use appropriate vocabulary related to their investigations of solids, liquids, and gases.</p> <p>Include: solid, liquid, substance, property, mass/weight, dissolve, gas, changes of state, water vapour, freeze, melt, condense, evaporate, boil, float, sink, buoyancy.</p> <p>GLO: C6, D3, D4</p>	<p>➤ Introduce, explain, use, and reinforce vocabulary throughout this cluster.</p>
<p>2-2-02 Identify substances, materials, and objects as solids or liquids.</p> <p>GLO: D3</p>	<p>➤ Solid or Liquid?</p> <p>Give students a collection of solids and liquids and ask them to sort and label the items. Have students re-sort the items several times, according to different rules. Following the sorting, have students share their sorting rules with the class. The teacher should lead a discussion modelling the use of the terms “solid” and “liquid” and identifying how to sort according to these categories. Show students another substance, material, or object and challenge them to identify whether it would belong in the solid or liquid group. Have them explain their thinking.</p>
<p>2-0-6c. Place materials and objects in a sequence or in groups using one or two attributes, and describe the system used. (Math SP-III.0.2) GLO: C2, C3, C5</p>	
<p>2-2-03 Investigate and compare properties of familiar solids.</p> <p>Include: have mass/weight, take up space, maintain their shape.</p> <p>GLO: C2, D3, E1</p>	<p>➤ Investigating Solids</p> <p>Have students explore solids in science centres, recording their observations in their science journals. The centres should contain a variety of solids.</p> <p>Centre 1: Do Solids Have Mass/Weight?</p> <p>Provide a balance scale. Have students investigate the mass/weight of several solids by using non-standard units. The student sheet for this centre should include the following questions for reflection:</p> <ul style="list-style-type: none"> • What did you discover about the solids as you used the balance scale? • What did you learn about solids at this centre? <p>Centre 2: Do Solids Take Up Space?</p> <p>Provide several containers (e.g., clear plastic cups, small jars, beakers, etc.) marbles, water, a variety of solids, and masking tape or a water soluble marker.</p>
<p>2-0-4a. Follow simple directions, and describe the purpose of steps followed. GLO: C2</p> <p>2-0-5b. Use, with guidance, tools to observe, measure, and construct. <i>Examples: ruler, metre stick, pan balance, magnifying glass, bathroom scale, thermometer...</i> (Math SS-VIII.1.2) GLO: C2, C3, C5</p> <p>2-0-5e. Record observations using written language, drawings, and, with guidance, charts. (ELA 4.1.2, 4.2.5) GLO: C2, C6</p>	

(continued)

TEACHER NOTES

SUGGESTIONS FOR ASSESSMENT

Caution: Remind students that they should not be tasting the solids or liquids used in the class unless they have specific instructions from their teacher to do so. Proper procedures for safety, materials management, and clean-up need to be established early.

Be sure to provide a variety of easily identifiable substances for the initial classifying. For the sorting following the class discussion, provide challenging items such as sand, salt, plasticine, marbles, etc.

Clear directions need to be provided for centre activities. Centre 2, in particular, requires very clear, step-by-step directions. These should use a combination of words and pictures.

In Grade 2, students are not differentiating between mass and weight (as per K-4 Mathematics). These terms can be used interchangeably.

Learning Log Entry: Solids

Have students complete the following in their learning logs after completing the investigations on solids.

Two things I learned about solids are

1. _____.
2. _____.

Look for

- an indication of the student's understanding of key concepts in order to provide direction for further teaching

PRESCRIBED LEARNING OUTCOMES

SUGGESTIONS FOR INSTRUCTION

Students will...

❶ Have students fill one container with water to the line indicated and then add one of the solids to the container of water, observing what happens to the level of the water.

❷ Have students totally fill a small container with water and then pour it into another container to measure (non-standard) how much water the container held. Students then put marbles into the original container and pour the measured water back in an attempt to re-fill it. Students measure to see how much water they were able to put in the container and how much was left over.

The student sheet for this centre should include the following questions for reflection:

- What happened to the water level when you added the solid?
- Why did the container hold less water when you added the marbles?
- What did you learn about solids at this centre?

Note: The property related to maintaining shape is addressed by outcomes 2-2-04 and 2-2-05.

➤ **Summarizing the Properties of Solids**

With students, discuss what they learned during their centre activities. Students can refer back to their observation and reflection sheets. Together, develop a list of properties of solids from the findings. Post this informational text where students can refer to it.

2-2-04 Investigate and compare properties of familiar liquids.
 Include: have mass/weight, take up space, have no definite shape.
 GLO: C2, D3

2-2-05 Identify similarities and differences among properties of familiar solids and liquids.
 GLO: D3, E1

➤ **Investigating Liquids**

Use the list of properties for solids to focus students' investigations of liquids. Provide students with a variety of familiar liquids such as water, milk, detergent, and syrup or oil. Have students work with liquids to answer the focus question for each centre.

Centre 1: Do Liquids Have Weight/Mass?

Provide a balance scale and non-standard units for weighing. Have students investigate the mass/weight of the liquids. Make sure students either weigh the empty container before adding a liquid or provide two of each container so that they can compare the empty container with the full container by placing them on either side of the scale. (Having lids will prevent spills.)

2-0-4e. Respond to the ideas and actions of others in building their own understandings. (ELA 1.1.2) GLO: C5, C7

2-0-5a. Make, with guidance, observations that are relevant to a specific question. GLO: A1, A2, C2

(continued)

(continued)

TEACHER NOTES

SUGGESTIONS FOR ASSESSMENT

There are a variety of ways for the students to use non-standard measurement to determine the amount of water the container held (Math Link). To make a special measuring container, students use masking tape or a water-soluble marker to mark off the water level. Alternatively, smaller containers, or “cups,” can be used, with students having to count how many “cups” of water the container held.

Detailed measurements are not required with this centre activity. Students simply need to see that the original container could not hold as much water when it also contained the marbles.

Self-Assessment: Centres

Answer Yes or No. (Teachers may choose to read these to students.)

1. I followed the directions at each centre.
2. I used the materials appropriately.
3. I recorded my observations.
4. I labelled all diagrams.
5. I answered the questions after finishing each activity.
6. I worked cooperatively.

PRESCRIBED LEARNING OUTCOMES	SUGGESTIONS FOR INSTRUCTION
<p><i>Students will...</i></p> <p>2-0-5b. Use, with guidance, tools to observe, measure, and construct. <i>Examples: ruler, metre stick, pan balance, magnifying glass, bathroom scale, thermometer...</i> (Math SS-VIII.1.2) GLO: C2, C3, C5</p> <p>2-0-7e. Describe, in a variety of ways, what was done and what was observed. <i>Examples: concrete materials, captioned drawings, oral language...</i> (ELA 4.1.2, 4.2.5) GLO: C6</p>	<p>The student sheet for this centre should include the following questions for reflection:</p> <ul style="list-style-type: none"> • What did you discover about the liquids as you used the balance scale? • What did you learn about liquids at this centre? <p>Centre 2: Do Liquids Take up Space?</p> <p>Have students completely fill a container with marbles. Have them add water to the container until it reaches the top. Have students predict whether they can add water to other solids in containers (e.g., blocks, sugar cubes, etc.). Have them test their predictions.</p> <p>The student sheet for this centre should include the following questions for reflection:</p> <ul style="list-style-type: none"> • Why were you still able to add water when the container seemed to be full with marbles? • What did you learn about liquids at this centre? <p>Centre 3: Do Liquids and Solids Maintain their Shape?</p> <p>Provide a variety of differently shaped containers. Have students put liquids into the containers and observe what happens to the shape of the liquid. (The liquid takes the shape of the container.) Have students repeat this pouring task using a medium-sized solid, such as a block or marble. (The solids do not take the shape of the container.)</p> <p>The student sheet for this centre should include the following questions for reflection:</p> <ul style="list-style-type: none"> • What happened to the shape of the liquids when you put them in different containers? • What happened to the shape of the solids when you put them in different containers? • What did you learn about liquids and solids at this centre? <p>➤ Summarizing the Properties of Liquids</p> <p>Discuss with students what they learned during their centre activities. Students can refer to their observation and reflection sheets. Together, develop a list of properties common to all liquids. Add a property to the solids list related to solids' maintaining their shape. Post this informational text where students can read it.</p>
	<p style="text-align: right;">(continued)</p>

TEACHER NOTES

SUGGESTIONS FOR ASSESSMENT

Film canisters used to hold liquids for this investigation must be totally full. Have students fill the canisters so that excess liquid spills out when the lid is put on. Students are most likely to see a difference in mass/weight with liquids such as syrup or oil as compared to water or rubbing alcohol.

Learning Log Entry: Liquids

Have students complete the following phrase:

Three things I learned about liquids are

1. _____.
2. _____.
3. _____.

Look for

- an indication of the student's understanding of key concepts in order to provide direction for further teaching

PRESCRIBED LEARNING OUTCOMES

SUGGESTIONS FOR INSTRUCTION

Students will...

➤ **Comparing Solids and Liquids**

Use a Venn diagram to compare the properties of liquids and solids. Print the information from the informational text posted in the classroom on individual cards or strips of paper. One fact is recorded on each strip. Use different-coloured paper for solids and liquids. Have students work with a partner to use a Venn diagram for comparing solids and liquids.

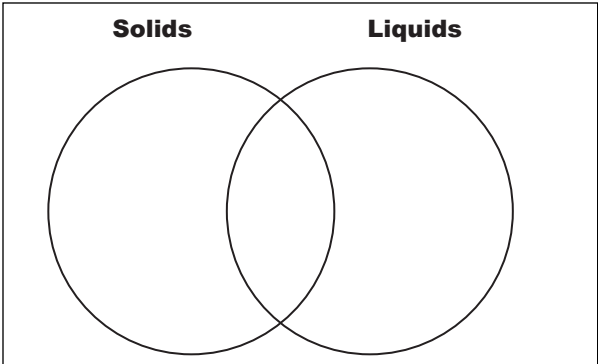

Provide the following slips of paper for students to place on the Venn diagram.



2-2-06 Distinguish between solids that dissolve in water and those that do not.
Examples: sugar dissolves in water, whereas sand does not...
GLO: D3, E1

➤ **Predict and Test**

Provide students with several different types of solids, including those that are powdered, crystallized, or granular (sugar, salt, drink crystals, sand). Have the students predict whether each solid will dissolve in water and then test to see if their predictions are correct. Before testing, some guidelines will need to be determined. As a class, decide whether stirring is permitted, and if so, how much. Predictions and observations should be recorded on a chart.

2-0-1b. Make predictions based on observed patterns or on collected data. (ELA 1.1.1, 1.2.1)
GLO: A1, C2
2-0-7a. Propose an answer to the initial question based on their observations. (Math SP-IV.2.2)
GLO: A1, A2, C2

TEACHER NOTES

SUGGESTIONS FOR ASSESSMENT

Including solids such as bouillon cubes and hard candy (things that will dissolve over time) can add another dimension to the activity. Students may leave solids that did not appear to dissolve in the water for several hours, or overnight, and observe them again.

At this age, students will likely have some familiarity with the term “dissolve.” For this grade, the term should be understood to mean “mixes in completely,” or seems to “disappear.”

PRESCRIBED LEARNING OUTCOMES
<i>Students will...</i>
<p>2-2-07 Explore interactions of familiar liquids with different surfaces, powdered solids, and other liquids, and describe how these interactions determine their uses. GLO: A5, B1, C1, C2</p>
<p>2-0-5a. Make, with guidance, observations that are relevant to a specific question. GLO: A1, A2, C2</p> <p>2-0-5e. Record observations using written language, drawings, and, with guidance, charts. (ELA 4.1.2, 4.2.5) GLO: C2, C6</p> <p>2-0-9b. Express enjoyment when sharing and discussing science-related experiences from daily life. GLO: C5</p>

SUGGESTIONS FOR INSTRUCTION

➤ **Investigating Liquids**

Provide students with a variety of familiar liquids such as oil, water, milk, vinegar, catsup, and syrup. Students will explore these liquids and their interactions at individual centres. Each station should have the same core set of liquids, allowing for on-going comparisons. The student sheets at each centre could include the headings: **What did you do? What did you see?**

Centre 1: Interaction with Different Surfaces

Have students explore the interaction of each liquid with wood (a wooden spoon or paint stir stick). Students dip the wood into each liquid, using a separate spoon for each liquid. Students observe what happens when they remove the wood (sticks, runs off). Have students place a small spoonful of each liquid onto samples of different surfaces (e.g., linoleum, glass plate, paper plate, bread). Students should carefully tilt the surface and observe what happens to the liquids. Students record their observations on the student sheet provided at the centre.

Centre 2: Interaction with Powdered Solids

Have students explore the interactions of liquids and solids by mixing a given amount of powdered drink mix with each liquid. Provide stirring tools. Have students place equal amounts of each liquid in clear plastic cups, then add an equal amount (a small scoop or spoonful) of the powder to each liquid. They should observe what happens, and then stir gently five times and observe again. Students record their observations on the student sheet provided at the centre.

Centre 3: Interaction with other Liquids

Have students explore the interactions of each liquid with food colouring. Have students add a drop of food colouring to each liquid and observe what happens (without stirring). Have students predict what would happen if the mixture were stirred. Students test to determine if their predictions were correct. Next, have students add a spoonful of oil to each liquid, stir, and observe what happens. Students record all their observations on the student sheet provided at the centre.

TEACHER NOTES

SUGGESTIONS FOR ASSESSMENT

Paper and Pencil Matching: Investigating Liquids

Answer the following questions:

1. Why is syrup good for pancakes?
2. Why is water good for drink mixes?
3. Which liquid would you use to polish your wooden furniture?
Why?

Look for reference to results of **Investigating Liquids** centres.

PRESCRIBED LEARNING OUTCOMES
<i>Students will...</i>
<p>2-2-08 Identify liquids used in the home, and describe how they are used.</p> <p><i>Examples: milk for drinking and cooking, detergent for cleaning...</i></p> <p>GLO: B1</p>
<p>2-0-1a. Ask questions that lead to investigations of living things, objects, and events in the immediate environment. (ELA 1.2.4, 3.1.2, 3.1.3; Math SP-I.1.2) GLO: A1, C2, C5</p> <p>2-0-4i. Recognize international symbols and the Canadian Safety Association signage, which provide information on the safety of substances. Include: flammable, explosive, corrosive, poisonous. GLO: C1</p> <p>2-0-5a. Make, with guidance, observations that are relevant to a specific question. GLO: A1, A2, C2</p> <p>2-0-5e. Record observations using written language, drawings, and, with guidance, charts. (ELA 4.1.2, 4.2.5) GLO: C2, C6</p>
<p>2-2-09 Compare different materials with respect to their capacity to absorb liquids, and describe how this capacity determines their uses.</p> <p>GLO: B1, C2, D3</p>
<p>2-0-1a. Ask questions that lead to investigations of living things, objects, and events in the immediate environment. (ELA 1.2.4, 3.1.2, 3.1.3; Math SP-I.1.2) GLO: A1, C2, C5</p> <p>2-0-3d. Identify tools and materials to be used, and explain their choices. GLO: C2, C3, C4</p> <p>2-0-5a. Make, with guidance, observations that are relevant to a specific question. GLO: A1, A2, C2</p> <p>2-0-5e. Record observations using written language, drawings, and, with guidance, charts. (ELA 4.1.2, 4.2.5) GLO: C2, C6</p> <p style="text-align: right;">(continued)</p>

SUGGESTIONS FOR INSTRUCTION

<p>➤ Survey: Liquids at Home</p> <p>As a take-home assignment, have students make a list of different types of liquids found in their homes along with their uses.</p> <table border="1" data-bbox="651 464 1312 590"> <thead> <tr> <th><u>Name of liquid</u></th> <th><u>How it is used</u></th> </tr> </thead> <tbody> <tr> <td>vanilla</td> <td>for flavour when baking</td> </tr> <tr> <td>syrup</td> <td>topping for pancakes/waffles</td> </tr> </tbody> </table>	<u>Name of liquid</u>	<u>How it is used</u>	vanilla	for flavour when baking	syrup	topping for pancakes/waffles
<u>Name of liquid</u>	<u>How it is used</u>					
vanilla	for flavour when baking					
syrup	topping for pancakes/waffles					
<p>Have students compile their results on a class chart. If possible, have them include pictures (from flyers and labels) of the liquids/containers.</p>						
<p>➤ What's Best?</p> <p>Have students identify which of the liquids from their station explorations would be suited to particular uses. Have students imagine that all of the liquids taste the same, allowing them to focus on the physical characteristics of the liquid and its possible use. Use the following format to help students identify suitable liquids and explain their choices (Link to 2-2-07).</p> <p>1). _____ would be useful for a topping for pancakes because it _____.</p> <p>2) _____ would be useful for mixing with grape crystals for a drink because it _____.</p>						
<p>➤ Investigating Absorbency</p> <p>Use the following questions to introduce the investigation:</p> <ul style="list-style-type: none"> • Do all materials absorb water? • Which materials absorb water the fastest? • Which materials absorb the most water? • How can we find these answers? <p>Provide students with a variety of different materials such as bond paper, paper towels, cotton, linen, wood, sponge, and plastic. Have students test the absorbency of each using an eyedropper and water. Have students count how many drops the material will absorb before the drops appear to stay on the surface. Students use a tally sheet to record the amount of water in drops absorbed.</p> <p style="text-align: right;">(continued)</p>						

TEACHER NOTES

SUGGESTIONS FOR ASSESSMENT

Have students use Blackline Master 1: Scientific Inquiry Recording Sheet : Grades 1 and 2.

The term **absorb** indicates that the water is soaked up to the point where you can no longer see the water drops.

Guide students to consider practicality in addition to absorbency when deciding which material is best for soaking up a spill. Discussions such as those related to the pros and cons of paper versus cloth towels should be encouraged.

Paper and Pencil Task: Investigating Absorbency

Provide students with the following scenario. Someone in the kindergarten class has spilled water on the table. They want to clean it up quickly so that it does not wet the floor/carpet. The children do not know which material they should use. What would you tell them? Explain your choice.

Look for

- identification of appropriate material
- reference to the exploration

PRESCRIBED LEARNING OUTCOMES
<i>Students will...</i>
<p>2-0-6c. Place materials and objects in a sequence or in groups using one or two attributes, and describe the system used. (Math SP-III.0.2) GLO: C2, C3, C5</p> <p>2-0-7a. Propose an answer to the initial question based on their observations. (Math SP-IV.2.2) GLO: A1, A2, C2</p> <p>2-0-7d. Connect new experiences, ideas, and information with prior knowledge and experiences. (ELA 1.2.1, 2.1.2) GLO: A2</p> <p>2-0-8a. Recognize that learning can come from careful observations and investigations. (ELA 3.3.4) GLO: A1, A2, C2</p>
<p>2-2-10 Describe useful materials that are made by combining solids and liquids.</p> <p><i>Examples: a drink made from crystals and water, a cake made from cake mix and water, glue made from flour and water...</i></p> <p>GLO: B1, D3</p>
<p>2-0-4h. Follow given safety procedures and rules. GLO: C1</p>
<p>2-2-11 Explore to determine that there is a substance around us called air.</p> <p>GLO: A2, C2, D3, D5</p> <p>2-2-12 Recognize that air is composed of several gases</p> <p><i>Examples: carbon dioxide, oxygen, nitrogen, water vapour...</i></p> <p>GLO: D3</p> <p style="text-align: right;">(continued)</p>

SUGGESTIONS FOR INSTRUCTION

Students should also make other observations both during and after each test (e.g., I could see the wetness spreading; the material fell apart when I picked it up). Have students use their data to place the materials in order from most to least absorbent. Considering both absorbency and the other characteristics they observed, have each group recommend which material they would use to clean up a spilled glass of water. Have them explain their choices.

➤ **Writing Riddles**

Have students work in groups to write a riddle based on one of the materials tested. This could be made into a “lift the flap” book. A sample of the actual material could be placed under the flap. The following captions could be used:

- I am an absorbent material.
- I soak up liquid quickly.
- I can hold a great deal of liquid.
- I come in a roll.
- I am often found in the kitchen.
- What am I? (paper towel)

➤ **Practical Products from Solids and Liquids**

Provide opportunities for students to bake cookies or bannock and/or mix their own beverages from powdered crystals. Encourage description and discussion of the process.

➤ **Art Connection: Papier Mâché**

Have students mix flour or wallpaper paste with water for papier mâché projects. Papier mâché can be used in the development of masks, jewellery, sculpture, etc.

➤ **Observing Air in the Environment**

Setting the context: Hold up a lunch bag in front of the class. As you remove items from the bag, challenge students to identify the objects as solids or liquids. After emptying the bag, ask students what is still left inside. Tell them they will be investigating this third type of material.

(continued)

TEACHER NOTES

SUGGESTIONS FOR ASSESSMENT

--

--

--

Observation Skills Checklist: Air

The student

- asks questions related to air and air composition
- makes relevant observations
- proposes answers to questions related to air
- uses a variety of sources to access information

The student records observations using

- words
- drawings
- other

PRESCRIBED LEARNING OUTCOMES	SUGGESTIONS FOR INSTRUCTION
<p><i>Students will...</i></p>	
<p>2-0-2a. Access information using a variety of sources. <i>Examples: elders, simple chapter books, concept books, CD-ROMs, Internet...</i> (ELA 1.1.2, 3.2.2 Math SP-II.1.2; TFS 2.1.1) GLO: C6</p> <p>2-0-4i. Recognize international symbols and the Canadian Safety Association signage, which provide information on the safety of substances. Include: flammable, explosive, corrosive, poisonous. GLO: C1</p>	<p>Have students undertake the following experiences:</p> <ul style="list-style-type: none"> • take a few deep breaths while placing their palms on their chest • observe a balloon as it is inflated • blow into a plastic bag or drag the open bag through the air and seal the bag • try to pour water into a jar via a funnel through its lid (use plasticine or a few drops of wax from a candle to seal the hole in the lid around the funnel). <p>Have students use the following questions for reflection:</p> <ul style="list-style-type: none"> • What did you feel in your chest? Why? • Why did the balloon increase in size? • What is inside the bag? • Why couldn't you pour water into the jar? (The jar was already full of air and there was no place for the air to go.) • If you cannot see air, how do we know it is all around us? (Link to Air & Water in the Environment 2-4-02, 2-4-03) <p>➤ What Is Air?</p> <p>Consolidate students' prior knowledge regarding the composition of air. (Link to Air & Water in the Environment 2-4-06, 2-4-07 for a discussion of water vapour.) Have students listen to, read, or view books, videos, and CD-ROMs. Include information and discussion on carbon monoxide detectors in homes or the use of oxygen for medical treatment.</p> <p>➤ Composition of Air: Demonstrations</p> <p>Complete the following demonstrations for students, ensuring that there is adequate opportunity for sharing and discussing observations.</p> <p>Demonstration 1: Oxygen</p> <p>Demonstrate the presence of oxygen in the air by placing a candle in a shallow pan filled with water. Light the candle. Place an empty clear glass jar over the candle. (The jar should be approximately one litre in size to provide enough oxygen to draw in the water.) As the flame goes out ask students to notice what is happening to the water in the jar. Discuss their observations.</p>
	<p>(continued)</p>

TEACHER NOTES

The term **air** is often used to describe the gas found all around us. Air is actually a combination of several gases. Many students will already be familiar with the names of some **common gases**. Approximately 78% of air is composed of nitrogen, 22% is oxygen, with minute quantities of carbon dioxide, ammonia, methane, sulfur dioxide, helium, and hydrogen. It is not important for students to know all of the gases that make up air. Students need to understand that when we talk about air we are talking about a mixture of gases, not a single gas.

Fire requires **oxygen** to burn. When the oxygen is used up the flame goes out. The water level in the jar will also rise as the oxygen is used up.

SUGGESTIONS FOR ASSESSMENT

Paper and Pencil Task: Air

Have students answer the following questions:

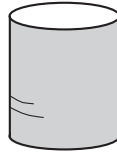

1. John says that this glass is empty.
Is he correct? Explain your thinking.

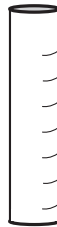

2. Ann wants to use the small glass to fill the tall cylinder with air. Will this work? Explain.

In question 1, the student should indicate that the glass is not empty. It is filled with air. In question 2, the student should indicate that it is not possible to do this. Both the glass and cylinder are already filled with air. Air as a gas does not “pour,” nor does it have any definite shape.

PRESCRIBED LEARNING OUTCOMES

Students will...

SUGGESTIONS FOR INSTRUCTION

Demonstration 2: Carbon Dioxide

Use a carbonated drink such as ginger ale and some raisins to demonstrate the presence of carbon dioxide. Carefully pour ginger ale into a clear glass. Try to preserve as much of the carbonation as possible. Drop in a few raisins. Ask students to observe the movement of the raisins. Have students explain their observations.

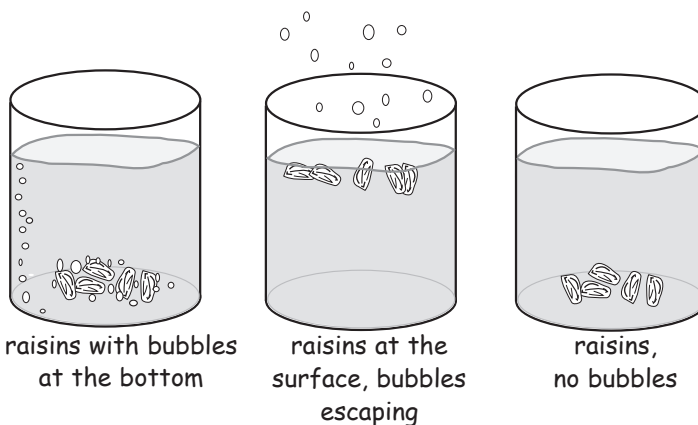

2-2-13 Identify properties of gases.

Include: occupy the space not taken up by solids and liquids, have no definite shape.

GLO: D3

2-0-6b. Discuss data and generate new questions from displayed data. (Math SP IV.1.2)
GLO: A1, A2, C2, C5

2-0-7a. Propose an answer to the initial question based on their observations. (Math SP-IV.2.2)
GLO: A1, A2, C2

2-0-7d. Connect new experiences, ideas, and information with prior knowledge and experiences. (ELA 1.2.1, 2.1.2) GLO: A2

➤ **Investigating Gases**

Set up centres to investigate the properties of gases.

Centre 1: Does Air Take up Space?

Have students put a crumpled piece of paper towel in the bottom of a transparent glass. (Make sure the paper stays in place when the glass is inverted.) Have them invert the glass, and, keeping it as straight as possible, place it carefully into a container of water. Students hold the glass steady while counting to ten. Students lift the glass out of the water without tipping it and observe the paper towel.

The student sheet for this centre should include the following question for reflection:

- Why did the paper towel stay dry?

(continued)

TEACHER NOTES

SUGGESTIONS FOR ASSESSMENT

The carbon dioxide gas from the drink sticks to the raisins and causes the raisins to rise to the surface. As the gas escapes into the air at the surface of the water, the raisins sink.

Air takes up the space in the glass and does not allow the water to enter and wet the towel.

PRESCRIBED LEARNING OUTCOMES

SUGGESTIONS FOR INSTRUCTION

Students will...

Centre 2: Does Air Have a Definite Shape?

Provide a variety of containers — boxes, bags, etc. Have students fill each container with air and try transferring the air/gas from one container to another in whatever manner they determine.

The student sheet for this centre should include the following questions for reflection:

- Was it easy to fill the container with air/gas?
- Did it matter what shape the container was? Large? Small? Long? Narrow?
- If you were able to transfer the air/gas from a small container to a large one, would the large container be partially full? Would the smaller container be completely empty? Why?

➤ **Summarizing the Properties of Gases**

With students, make a class list of the properties of gases discovered through their explorations. Post this information where students can reread it.

2-2-14 Explore to determine how water can be made to change from one state to another and back again. Include: addition or removal of heat. GLO: C2, D3, D4, E3

➤ **Investigating Changing States of Water**

Set up investigations that allow students to explore changing the states of water. Make connections to Cluster 4, Air and Water in the Environment, outcomes 2-4-06 and 2-4-07.

Investigation 1: Liquid to Solid

Have students take the temperature of the water before placing it in a freezer (or outside). Have students take and record the temperature every half hour. When the ice is frozen solid, have students complete the following statement:

As the water froze, its temperature went _____ . (up or down)

Investigation 2: Solid to Liquid

Have students take the temperature of a container of ice cubes before the investigation. Set the ice cubes in various locations within the classroom. Have students take and record the temperature of the water as the ice melts. When the ice has fully melted, have students complete the following statement:

As the ice melted, the temperature of the water went _____ . (up or down)

2-0-4h. Follow given safety procedures and rules. GLO: C1
2-0-5b. Use, with guidance, tools to observe, measure, and construct. *Examples: ruler, metre stick, pan balance, magnifying glass, bathroom scale, thermometer...* (Math SS-VIII.1.2) GLO: C2, C3, C5
2-0-5c. Estimate and measure the passage of time related to minutes and hours. (Math SS-VI.1.2) GLO: C2, C3, C5

(continued)

TEACHER NOTES

SUGGESTIONS FOR ASSESSMENT

--

Learning Log Entry: Gases

Have students complete the following phrase:

Three things I learned about gases are

1. _____
2. _____
3. _____

Look for

- an indication of the student's understanding of key concepts in order to provide direction for further teaching

Only red alcohol thermometers should be used for the investigations.

As the water freezes, students should observe that a layer of ice forms on top first. Discuss how this relates to safety on ice in the fall. A layer of ice on top is not an indication that a body of water is frozen throughout and safe to walk on.

PRESCRIBED LEARNING OUTCOMES

SUGGESTIONS FOR INSTRUCTION

Students will...

Investigation 3: Liquid to Gas

Use a kettle or pot to boil water. Take the temperature of the water prior to heating (students can do this) and at the boiling point (the teacher should do this). Have students carefully observe what is happening (they should see steam). Using oven mitts and a very cold serving spoon or ladle, hold the spoon over the steam so that student see the condensation and realize that the water changed to vapour and then back to liquid on the spoon. Have students observe the temperature change from the time the water was first heated to the point where it began to boil.

As the water was heated, its temperature went _____ . (up or down)

2-2-15 Recognize that the states of solids and liquids remain constant in some circumstances, but may change in other circumstances.

Examples: liquids may freeze when temperature drops, solids may melt when heated, solids remain solid when broken...

GLO: D3, E3

➤ **A Change or Not a Change?**

Have students identify the pictures that indicate a change of state. Have them explain their thinking. Examples of pictures could include the following:

- breaking a crayon
- sharpening a pencil
- putting juice into an ice-cube tray in the freezer
- pouring milk into a glass
- leaving an ice cream cone in the sun

2-0-2a. Access information using a variety of sources. *Examples: elders, simple chapter books, concept books, CD-ROMs, Internet...* (ELA 1.1.2, 3.2.2 Math SP-II.1.2; TFS 2.1.1) GLO: C6

2-0-2b. Match information to research needs. (ELA 3.2.3, 3.3.3) GLO: C6, C8

2-2-16 Describe ways humans dispose of solids and liquids to maintain a clean and healthy environment.

Examples: take used car oil and old paints to collection sites, recycle newspapers...

GLO: B5

➤ **Where Does It Go?**

Bring in a bag of recyclable solids such as newspapers, tin cans, plastic bottles, cardboard, and glass containers. Have students in small groups identify at least two methods for disposing of the items. Students should answer the following questions for reflection and share their answers with the class:

- Is there more than one way to dispose of the same item?
- What is good about throwing things in the garbage? What is bad?
- What is good about sending things to be recycled? What is bad?

Examples: convenience, cleanliness, time, lack of places to take recyclables, landfill sites are becoming too full...

2-0-4e. Respond to the ideas and actions of others in building their own understandings. (ELA 1.1.2) GLO: C5, C7

2-0-9a. Willingly consider other people's views. GLO: C5, C7

(continued)

TEACHER NOTES

SUGGESTIONS FOR ASSESSMENT

Caution: Take steps to ensure safety of both teacher and students when boiling water.

Student Journal Entry: Where Does It Go?

Have students answer the following questions:

1. Tom has a can of old paint. He wants to throw it out. What should he do? Why?
2. Sarah has a box of glass bottles. She wants to throw them out. What should she do? Why?

Look for

- disposing of paint at a community disposal centre
- recycling of glass in some way

PRESCRIBED LEARNING OUTCOMES	SUGGESTIONS FOR INSTRUCTION
<p><i>Students will...</i></p>	<p>➤ Research: The Recycling Process Have students work with a partner to</p> <ol style="list-style-type: none"> a) select a recyclable solid and research what happens to it when it goes through the recycling process, or b) research the disposal of liquids such as car oil or paint. <p>➤ Guest Speaker/Field Trip Invite a guest to speak about the recycling of specific solids or liquids, or go on a field trip to a recycling depot if one is available in the area.</p>
<p>2-2-17 Predict and test to determine whether a variety of materials float or sink in water. GLO: C2, D3</p> <p>2-2-18 Demonstrate ways to make sinking materials float and floating materials sink. GLO: B1, C3</p>	<p>➤ Float or Sink? Provide a variety of objects made of different materials (e.g., wood, plastic, rubber, styrofoam, metal, etc.). Have students predict if the material will float or sink. Have students record their predictions and then test to see if their predictions were accurate.</p> <p>➤ Changing Buoyancy Challenge students to find ways to make sinking things float or floating things sink. Use the objects from Float or Sink? as well as some others. Examples: plasticine sinks when it is in one ball but floats when it is flattened out (the surface area is increased); a tin-foil boat floats but when additional weight is added it will sink; a pencil will float if carefully placed horizontally on the surface of the water but will sink if dropped in horizontally...</p>
<p>2-0-1b. Make predictions based on observed patterns or on collected data. (ELA 1.1.1, 1.2.1) GLO: A1, C2</p> <p>2-0-4g. Verbalize questions, ideas, and intentions during classroom activities. GLO: C6</p>	

TEACHER NOTES

SUGGESTIONS FOR ASSESSMENT

--

Performance Task: Changing Buoyancy

Provide students with a large container of water (aquarium, basin) and a ping pong ball. Ask students to make the ping pong ball sink. Observe.

Scoring Rubric

- 4** Student is able to solve the problem independently and is able to clearly communicate his/her thinking.
- 3** Student is able to solve problem with some assistance. Communication of thinking is clear.
- 2** Student makes several attempts to solve the problem but is unable to make the ball sink. Communication of thinking is partially clear.
- 1** Student makes an attempt to solve the problem but is unable to make the ball sink. Communication of thinking is unclear.

--

PRESCRIBED LEARNING OUTCOMES
<i>Students will...</i>
<p>2-2-19 Use the design process to construct an object that is buoyant and able to support a given mass/weight. GLO: C3</p>
<p>2-0-1c. Identify practical problems to solve in the immediate environment. GLO: C3</p> <p>2-0-3a. Brainstorm, with the class, possible solutions to a practical problem; and in small groups, reach consensus on a solution to implement. (ELA 1.2.3, 2.2.2) GLO: C3, C7</p> <p>2-0-3b. Create, with the class, a plan to solve a problem or meet a need. <i>Examples: identify simple steps to follow, prepare a drawing of the object to be constructed...</i> (ELA 1.2.3) GLO: C3, C7</p> <p>2-0-3c. Develop, as a class, limited criteria to evaluate an object or device based on its function and aesthetics. GLO: C3, C7</p> <p>2-0-3d. Identify tools and materials to be used, and explain their choices. GLO: C2, C3, C4</p> <p>2-0-4b. Construct an object or device to solve a problem or meet a need. GLO: C3</p> <p>2-0-4c. Test an object or device with respect to pre-determined criteria. GLO: C3, C5</p> <p>2-0-4d. Identify and make improvements to an object or device with respect to pre-determined criteria. GLO: C3</p> <p>2-0-7b. Propose a solution to the initial problem. GLO: C3</p> <p>2-0-7c. Identify new problems that arise. GLO: C3</p>

SUGGESTIONS FOR INSTRUCTION

➤ **Design Project**

Sample Context: Jack Be Nimble wants to make a floating candle. The candle has a mass of 50 grams. Jack Be Nimble asks you to help him design a device to hold the candle. Possible evaluation criteria could include the following:

- holds 50 grams without sinking or allowing any water onto the candle
- is made from flame-proof materials
- is pleasing to look at
- is easy and safe to use

Have students use Blackline Master 3: Design Process Recording Sheet: Grades 1 and 2.

TEACHER NOTES

SUGGESTIONS FOR ASSESSMENT

The teacher may choose to provide a selection of small candles and ask the students to decide on the type of material they wish to use for the candle holder. Small bowls can be used for the water source.

Alternatively, the teacher can provide the materials to be used. In either case, common household materials should be used.

Students will need to address the issue of fireproofing (or preventing melting) in their designs. Lining containers with foil is a good solution.

Marbles or coloured stones are useful for placing in the water as a decoration. This could be a project that is taken home as a gift for a special occasion.

Design Project Checklist: Buoyant Objects

The student

- identifies the problem
- contributes to brainstorming
- contributes to the creation of a plan
- helps to develop criteria
- constructs buoyant object
- tests object based on criteria
- makes improvements

Student Self-Assessment of Product

My object met the following criteria: (example)

- held 50 g without sinking
- made from flame-proof materials
- nice to look at
- easy to use
- safe to use

I can improve my object by _____

After I made the changes, my object _____

NOTES

Grade 2

Cluster 3: Position and Motion

Overview

The study of position and motion helps children develop a sense of space as well as an understanding of the relationship between stationary and moving objects, including themselves. Through observations and the use of specific vocabulary, students develop their ability to describe the position and motion of objects and recognize the effects of pushes and pulls on the motion of an object. In exploring motion, students investigate inclined planes, and wheels and axles as types of simple machines. They determine how these simple machines make it easier to move things and how friction affects the motion of objects.

PRESCRIBED LEARNING OUTCOMES

SUGGESTIONS FOR INSTRUCTION

Students will...

2-3-01 Use appropriate vocabulary related to their investigations of position and motion.
 Include: position, stationary, above, between, near, far from, next to, below, in front of, behind, to the right/left, perspective, motion, push, pull, friction, slope, inclined plane, wheel, axle, rotate, clockwise, counterclockwise.
 GLO: C6, D4

- Introduce, explain, use, and reinforce vocabulary throughout this cluster.
- **Picture Dictionary**
 Have students develop a picture dictionary of terms used during this cluster. Students should draw and label each term on separate sheets of paper. At the end of the cluster, students arrange the sheets in alphabetical order and bind them in book form.

2-3-02 Explore and describe the position of a stationary object with reference to themselves, to other objects, or to a specific area.
 Include: above, between, near, far from, next to, below, in front of, behind, to the right/left.
 GLO: D4

- **Identifying Points of Reference**
 How can directions be given so that everyone in the classroom can locate a certain object? With students, brainstorm and list specific terms of reference in the class to describe location (e.g., near the door, below the teacher’s desk, between the windows). Post these where students can easily refer to them.

2-3-03 Explore and describe changes in the position of an object in relation to its original position, themselves, or another object.
 GLO: D4

- **Where Is It?**
 Have the students identify the location of specific objects in relation to another object in the classroom by asking questions such as “Where is the pencil sharpener?” Encourage students to use the points of reference provided above, as well as others, to provide responses that would help someone in the classroom to locate the named objects. For example, “The pencil sharpener is below the light switch that is on the wall next to the door.”

2-3-04 Explore and describe the position of an object viewed from a perspective different from one’s own.
 GLO: D4

- **Body Reference Points**
 Introduce the idea that each student’s body can be used as a reference point or a reference frame. Descriptions could include statements such as: is in front of Ahmad; is between Cari and Saul; or is one metre to my left. Name specific objects in the classroom and have students use their classmates’ and their own bodies as reference points to describe location. Have students describe the location of the same objects using fixed or stationary objects in the classroom as references. Compare the two types of descriptions. Have students recognize that, unlike the environmental reference objects that are fixed, a person’s body is not. When people move, their reference frames change.

2-3-05 Explore and describe how changing the position of one’s own body affects perspective with reference to a stationary object.
 GLO: D4, E3

2-0-4g. Verbalize questions, ideas, and intentions during classroom activities.
 GLO: C6
2-0-5e. Record observations using written language, drawings, and, with guidance, charts.
 (ELA 4.1.2, 4.2.5) GLO: C2, C6

(continued)

TEACHER NOTES

SUGGESTIONS FOR ASSESSMENT

It is important for students to learn to describe the relative position of stationary or moving objects using reference objects. Reference objects are typically things that are easy to locate and identify. It is also important that students develop abilities to see and locate stationary objects and objects in motion from a point of view different from their own.

Interview (2-3-02 to 2-3-05)

Before the interview, collect several small toys/objects (e.g., block, doll house, bear, etc.) to be used as reference points.

- Using a reference point, move a toy to various positions and have the student describe its location. Ask: Where is the (bear)?

The student uses

- | | |
|---------------------------------------|--------------------------------------|
| <input type="checkbox"/> above | <input type="checkbox"/> between |
| <input type="checkbox"/> near to | <input type="checkbox"/> far from |
| <input type="checkbox"/> next to | <input type="checkbox"/> below |
| <input type="checkbox"/> in front of | <input type="checkbox"/> behind |
| <input type="checkbox"/> to the right | <input type="checkbox"/> to the left |

- Have the student describe the position of the toy after moving it from its original position, using a reference point and themselves.

Ask: Where is the bear now?

The student

- describes position using reference point
- describes position using himself/herself as reference point

- Use 3 different toys (bears). Have students describe the locations of each toy based on each of the other toy's perspectives.

Example: bear 1 bear 2 bear 3

Where is bear 2? (Behind bear 1, in front of bear 3, to the right of bear 1, to the left of bear 3.)

Comments: _____
_____.

(continued)

PRESCRIBED LEARNING OUTCOMES

SUGGESTIONS FOR INSTRUCTION

Students will...

- **Where Is It Now?**
 Part 1) After describing the position of an object, have a student move to a new location and describe the object’s position from this new perspective. Students should use both stationary and body reference points.

 Part 2) After describing the position of an object, the teacher should change its position and encourage students to describe the change in as many ways as possible. Descriptions should describe the change in the following ways: in relation to its original position (e.g., moved to the right), in relation to themselves (e.g., moved closer to me), and in relation to another object (e.g., moved behind the desk).
- **Name that Object Game**
My View: Have students work in pairs to describe where an object is located in relation to themselves and other objects in the classroom. Have one student provide a description of an object’s location. Have the second student (who is sitting beside the first student, facing in the same direction) identify the object. Encourage students to be active listeners as they practise using precise language to describe position.

Your View: Repeat the activity above, but this time have students sitting facing each other. They must describe an object’s location from their partner’s perspective.

2-3-06 Describe the motion of various objects and living things.
Examples: spinning, swinging, bouncing, sliding, rolling, jumping...
 GLO: D1, D4

- **Simon Says**
 Play a game of “Simon Says...” to explore movement and develop the cluster vocabulary. Example: Simon says jump in place. Simon says spin around. Play this game outdoors or in the gym to encourage movement.

2-0-1a. Ask questions that lead to investigations of living things, objects, and events in the immediate environment. (ELA 1.2.4, 3.1.2, 3.1.3; Math SP-I.1.2) GLO: A1, C2, C5
2-0-2a. Access information using a variety of sources. *Examples: elders, simple chapter books, concept books, CD-ROMs, Internet...* (ELA 1.1.2, 3.2.2 Math SP-II.1.2; TFS 2.1.1) GLO: C6
2-0-2b. Match information to research needs. (ELA 3.2.3, 3.3.3) GLO: C6, C8
2-0-4e. Respond to the ideas and actions of others in building their own understandings. (ELA 1.1.2) GLO: C5, C7

- **Picture Sort**
 Have students sort and classify pictures of animals according to how they move (link to Growth and Changes in Animals, 2-1-12).
 Example:
- | | | | |
|-----------------|------------|-----------------|-------------|
| <u>Hop/Jump</u> | <u>Fly</u> | <u>Walk/Run</u> | <u>Swim</u> |
| kangaroo | robin | dog | fish |
| frog/toad | bat | cheetah | tadpole |

(continued)

(continued)

TEACHER NOTES

SUGGESTIONS FOR ASSESSMENT

Young children tend to view objects from their own point of view. They need to understand that the position of an object is relative. (It depends upon the reference frame that is used to describe it.) One student's reference frame will result in a different description of an object's position from that of a classmate.

4. Have the students describe the position of an object from their perspective. Then, have them describe its position from the interviewer's perspective.

The student describes

own perspective

other perspective

Comments: _____

5. Have the students describe the position of an object. Then have them move to another location and describe the position of the same object.

The student

clearly describes the position of the object

uses reference points

uses "direction" or position language

clearly describes the position from the different perspectives

PRESCRIBED LEARNING OUTCOMES

SUGGESTIONS FOR INSTRUCTION

Students will...

2-0-4f. Work in a variety of cooperative partnerships and groups. (ELA 5.2.1) GLO: C7
2-0-6c. Place materials and objects in a sequence or in groups using one or two attributes, and describe the system used. (Math SP-III.0.2) GLO: C2, C3, C5

➤ **Exploring Objects that Move**

Set up a centre with an assortment of simple mechanical toys and objects that can be set in motion. If possible, include the following objects:

- wheel and axle systems that rotate around an axis such as toy cars
- objects that spin rapidly such as tops, yo-yos, button and string zoomers, and gyroscopes
- objects that swing (move back and forth) such as a pendulum
- objects that bounce (strike an object and rebound) such as rubber balls
- objects that slide (move over a surface while maintaining continuous contact) such as hockey pucks, shuffleboard disks, or curling stones
- objects that roll (move along by revolving on an axis or by repeatedly turning over) such as marbles

Have the students describe how these objects move.

2-3-07 Recognize that the position and motion of an object can be changed by a push or a pull and the size of the change is related to the strength of the push or pull.

GLO: D4

2-0-4a. Follow simple directions, and describe the purpose of steps followed. GLO: C2
2-0-5d. Estimate and measure length using standard units. (Math SS-I.1.2) GLO: C2, C3, C5
2-0-5e. Record observations using written language, drawings, and, with guidance, charts. (ELA 4.1.2, 4.2.5) GLO: C2, C6
2-0-9c. Take the time to repeat a measurement or observation for greater precision or detail. GLO: C5

➤ **Investigating Changes in Position and Motion**

Have students work in small groups to investigate how pushes and pulls affect the position and motion of objects. Provide students with several different objects such as toy trucks, hockey pucks, shuffleboard rocks, or pull toys. Have students move each object using different amounts of relative force (push it hard, or push it lightly) for each trial. Have students measure the distance the object travelled each time (e.g., mark off distances on the floor, count floor tiles) and record their information in a chart such as the one below.

Toy Car

Strength of push	Distance travelled
light push	_____
medium push	_____
hard push	_____

Use the following questions to reflect on the investigation:

- What did you discover about changing the position and motion of an object? (The size of the change is related to the strength of the push or pull.)
- How might this information be helpful? (Curlers need to know how hard to throw a rock depending on the situation, hockey/ringette players need to know where the puck/ring needs to go and how hard to shoot it.)

Have students record in their science journals their understanding of how the position and motion of objects are changed in relation to pushes and pulls.

TEACHER NOTES

SUGGESTIONS FOR ASSESSMENT

Learning Log Entry: Exploring Objects that Move

Have students summarize what they learned about how different toys/objects move by completing the following:

Toys and objects move in different ways. At the centre, I learned that _____
_____.

Look for

- | | |
|---------------------------------|---------------------------------|
| <input type="checkbox"/> rotate | <input type="checkbox"/> bounce |
| <input type="checkbox"/> spin | <input type="checkbox"/> slide |
| <input type="checkbox"/> swing | <input type="checkbox"/> roll |
| <input type="checkbox"/> other | |

It is not important for students to accurately measure the strength of a push or the distance travelled. However, they should be provided with enough experiences to realize that the strength of the push has a direct effect on the size of the change in position.

Discussions of **pushes and pulls** develop into an understanding of the concept of **force**. While students are not expected to use the term force at this grade, encourage proper usage should students already be using the term.

PRESCRIBED LEARNING OUTCOMES
<i>Students will...</i>
<p>2-3-08 Compare and describe the effects of friction on the motion of objects and humans when travelling across different surfaces.</p> <p><i>Examples: wheels of a toy on tile, sandpaper, or foam rubber; shoes on carpet, tile, or ice...</i></p> <p>GLO: C2, D4</p>
<p>2-0-7a. Propose an answer to the initial question based on their observations. (Math SP-IV.2.2) GLO: A1, A2, C2</p> <p>2-0-7d. Connect new experiences, ideas, and information with prior knowledge and experiences. (ELA 1.2.1, 2.1.2) GLO: A2</p> <p>2-0-8a. Recognize that learning can come from careful observations and investigations. (ELA 3.3.4) GLO: A1, A2, C2</p>

SUGGESTIONS FOR INSTRUCTION

➤ **How Well Does It Move?**

Set up several centres in which students explore friction and motion. At each centre, provide students with a variety of surfaces such as tiles, sandpaper, foam rubber, and carpet. Centres 2 and 3 require ramps. Have students record their observations at each centre.

Centre 1: Objects with wheels

Centre 2: Objects that slide

Centre 3: Objects that roll

When students have had the opportunity to work at each centre, have them reflect on the learning experiences, using the following discussion questions:

- On which surface(s) does the object move the easiest?
- On which surface(s) does the object have the most difficulty moving?
- Are there any surfaces that do not seem to make a difference to the movement of the object?
- Why do certain surfaces affect the motion of objects?

➤ **Practical Examples of Friction**

With students, brainstorm and list examples of how friction is important in daily life. Examples include: sand is put on ice to make it easier for walking, curlers use a “slider” on their shoes to allow easier movement on ice, athletic shoes have special textures to prevent slipping, etc.

TEACHER NOTES

SUGGESTIONS FOR ASSESSMENT

If students have not used the term **friction** in their discussions, introduce it and model its use as a way to talk about the resistance to motion between two surfaces.

Paper and Pencil Task: How Well Does It Move?

Student directions: The entranceway of the school has a very slippery floor. The teacher is worried about students falling and hurting themselves. What could be done to make this area safer? Explain your answer.

Look for

- a surface that will increase friction
- use of the term “friction” in the explanation

PRESCRIBED LEARNING OUTCOMES
<i>Students will...</i>
<p>2-3-09 Explore and describe the effects of changing the slope of an inclined plane on the downward motion of an object and the effort needed to push or pull an object upward.</p> <p>GLO: C2, D4</p>
<p>2-0-4a. Follow simple directions, and describe the purpose of steps followed. GLO: C2</p> <p>2-0-5a. Make, with guidance, observations that are relevant to a specific question. GLO: A1, A2, C2</p> <p>2-0-7a. Propose an answer to the initial question based on their observations. (Math SP-IV.2.2) GLO: A1, A2, C2</p>

SUGGESTIONS FOR INSTRUCTION

➤ **Investigating the Effect of Incline on Motion, Part 1**

Have students work in small groups to determine how changing the slope of an inclined plane affects the downward motion of objects. Test a variety of objects for each slope. Have students release the object at the top of the slope and measure the distance travelled using standard measurements, e.g., decimetres, metres. Include objects that move in different ways. Have students record their observations in a chart like the following:

Distance Travelled

<u>Object</u>	<u>1st Slope</u> <i>(least steep)</i>	<u>2nd Slope</u>	<u>3rd Slope</u> <i>(steepest)</i>
toy car	_____	_____	_____
ping pong ball	_____	_____	_____
pencil	_____	_____	_____
roller skate	_____	_____	_____

Ask the following question:

- How does the slope affect an object’s downward motion? (The steeper the slope, the farther the object will travel.)

➤ **Investigating the Effect of Incline on Motion, Part 2**

Have groups of students use the toy car or roller skate and the three slopes from the previous learning experience to explore how easy or difficult it is to have the object travel up the different slopes. Have students test the slopes by releasing the car or skate from the base with enough push (force) to get the object to travel to the top of the slope. Following the tests, have students order the slopes according to the effort needed to push the object to the top.

Ask students the following question:

- How does the slope affect the effort needed to push an object to the top? (The steeper the slope, the harder the push needed.)

Have students use Blackline Master 1: Scientific Inquiry Recording Sheet: Grades 1 and 2

TEACHER NOTES

SUGGESTIONS FOR ASSESSMENT

An **inclined plane** is a slanting surface that connects one level to a higher level. The slanting surface (slope) can be gradual or steep.

Paper and Pencil Task: Inclined Planes

Ping wants to use his skateboard to reach the top of a hill. He has a choice of three ramps from which he can begin. Which should he use, and why?

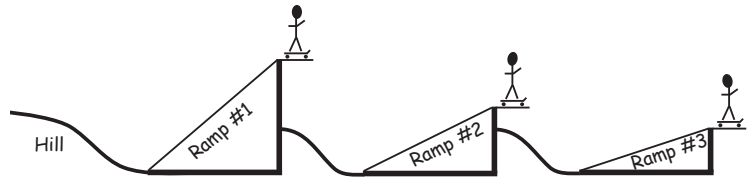

Look for

- ramp #1
- ramp #1 is steeper and Ping would travel farther.

What else could Ping do to make sure he gets to the top?

Look for

- push off hard when he starts

PRESCRIBED LEARNING OUTCOMES

SUGGESTIONS FOR INSTRUCTION

Students will...

2-3-10 Identify how humans use inclined planes to make motion easier.
Examples: staircase, playground slide, wheelchair ramp, ramp on a moving van...
GLO: B1, D4

2-0-4h. Follow given safety procedures and rules. GLO: C1
2-0-5e. Record observations using written language, drawings, and, with guidance, charts. (ELA 4.1.2, 4.2.5) GLO: C2, C6
2-0-7d. Connect new experiences, ideas, and information with prior knowledge and experiences. (ELA 1.2.1, 2.1.2) GLO: A2

- **Investigating How Humans Use the Inclined Plane**
Use a heavy object (that can be tied to a rope) and an inclined plane that is safe and sturdy enough to allow a student to walk on it while pulling a heavy object (a wheelchair ramp works well). The slope should not be higher than the vertical distance a student can lift the heavy object off the floor (chest height, perhaps). Ask students to lift an object off the floor to the indicated height. Discuss whether they found it easy or hard to do. Then, have them use an inclined plane to pull the object up to an equivalent vertical height. Discuss how this compares with lifting the object. Which method required more effort?
- **Science Journals**
Have students use labelled diagrams and text to explain how inclined planes help humans move heavy objects.
- **Partner Brainstorming**
Have students work in pairs to identify examples of inclined planes in their community such as a toboggan slide, playground slide, ski hill, wheelchair ramp, etc. Have students share their partners' lists and compile a class list.

2-3-11 Explore toys to determine how wheels and axles interact and move.
GLO: C2, D4

2-3-12 Recognize that the wheels of a vehicle rotate clockwise or counterclockwise depending on the direction of motion of the vehicle.
GLO: D4

2-3-13 Identify how humans use the wheel and axle to make movement easier.
Examples: moving dolly, wheelbarrow, cart, wagon...
GLO: B1, D4

(continued)

- **Picture Glossaries**
Have students use toy cars or trucks to explore the movement of wheels and axles. Have them sketch and label their observations. Ensure that students observe the following:
 - the interaction of the wheel and axle
 - the movement of the wheels on the driver's side when the car is pushed forward
 - the movement of the wheels from the passenger's side when the car is pushed forward
 - the movement of the wheels from the driver's side when the car is pushed backward and
 - the movement of the wheels from the passenger's side when the car is pushed backward.
 - **Wheels and Axles in the Environment**
Part 1) Have students repeat the task of pulling a heavy object up an inclined plane (wheelchair ramp). This time, challenge them to think of how rollers could help make their job easier. Use simple rollers to move the object up the ramp. Discuss how this made the job easier and identify any problems they had (keeping the rollers
- (continued)

TEACHER NOTES

SUGGESTIONS FOR ASSESSMENT

An **inclined plane** is an example of a **simple machine**. Simple machines help to make work easier.

Science Journal Entry

Provide students with the following scenario: A child wants to move a heavy box up the stairs. What is the easiest way to get the box up the stairs? Use labelled diagrams and words in your answer.

Look for

- a ramp (inclined plane)
- explanation that less effort is needed when you use a ramp (The work is easier.)

The **wheel and axle** is one type of **simple machine**. The wheel is connected to the axle. When the wheel is turned the axle is also turned. When the axle is turned the wheels are turned. One complete turn of the wheel causes one complete turn of the axle. When the toy is pushed forward, the wheel and axle, when viewed from the driver’s side of the vehicle, turn in a counterclockwise direction.

When the same forward movement of the vehicle is viewed from the passenger’s side, the wheel and axle turn in a clockwise direction. When the toy is pushed backward, the wheel and axle, when viewed from the driver’s side of the vehicle, move in a clockwise direction. When viewed from the passenger’s side of the vehicle, the wheel and axle move in a counterclockwise direction.

PRESCRIBED LEARNING OUTCOMES

SUGGESTIONS FOR INSTRUCTION

Students will...

2-0-4g. Verbalize questions, ideas, and intentions during classroom activities. GLO: C6
2-0-4h. Follow given safety procedures and rules. GLO: C1
2-0-7e. Describe, in a variety of ways, what was done and what was observed. *Examples: concrete materials, captioned drawings, oral language...* (ELA 4.1.2, 4.2.5) GLO: C6
2-0-9a. Willingly consider other people's views. GLO: C5, C7

2-3-14 Use the design process to construct a vehicle with wheels and axles that meets given criteria.
 GLO: C3, D4

2-0-1c. Identify practical problems to solve in the immediate environment. GLO: C3
2-0-3a. Brainstorm, with the class, possible solutions to a practical problem; and in small groups, reach consensus on a solution to implement. (ELA 1.2.3, 2.2.2) GLO: C3, C7
2-0-3b. Create, with the class, a plan to solve a problem or meet a need. *Examples: identify simple steps to follow, prepare a drawing of the object to be constructed...* (ELA 1.2.3) GLO: C3, C7
2-0-3c. Develop, as a class, limited criteria to evaluate an object or device based on its function and aesthetics. GLO: C3, C7
2-0-3d. Identify tools and materials to be used, and explain their choices. GLO: C2, C3, C4
2-0-4b. Construct an object or device to solve a problem or meet a need. GLO: C3
2-0-4c. Test an object or device with respect to pre-determined criteria. GLO: C3
2-0-4d. Identify and make improvements to an object or device with respect to pre-determined criteria. GLO: C3
2-0-7b. Propose a solution to the initial problem. GLO: C3
2-0-7c. Identify new problems that arise. GLO: C3
2-0-8b. Recognize that tools are developed in response to human needs. GLO: A3, B2

in place). Repeat the procedure using a device with wheels (a cart) and compare this with their results using the rollers.
 Part 2) Have students work in small groups to draw or find pictures of machines/tools with wheels. Have students glue the pictures on chart paper and record how each example makes work easier for humans.

<u>Picture of machine/tool</u>	<u>How it helps</u>
(wheelbarrow)	helps carry things such as dirt from place to place

➤ **Gallery Walk**
 Post the charts and use a Gallery Walk (Brownlie and Close, 1992) to facilitate the sharing of information. (Note: Gallery Walk is discussed in *ELA, Strategies* pp. 202-203.)

➤ **Design Project: A Vehicle with Wheels and Axles**
 Use literature to help set the context for the design task. For example, identify a practical problem in a story that involves a character having to transport something from one place to another, or who needs to travel from one place to another. Sample criteria for the creation of a vehicle include

- contains 4 wheels, 2 axles
- seating space for at least the driver
- space for cargo (4 blocks)
- sturdy (doesn't fall apart under the load)
- able to travel in a straight line down a ramp when released from the top

Students can make vehicles from a variety of ready-made objects including cereal boxes, pop cans, or milk cartons.

(continued)

TEACHER NOTES

SUGGESTIONS FOR ASSESSMENT

Have students use Blackline Master 3: Design Process Recording Sheet: Grades 1 and 2.

Design Process Checklist: Vehicles

The student

- understands the problem
- contributes to brainstorming
- contributes to the creation of a plan
- develops criteria with the class
- selects appropriate materials and tools
- constructs vehicle with wheels and axles
- uses tools and materials safely
- tests vehicle based on criteria
- suggests and makes improvements to the vehicle

Student Self-Assessment of the Construction and/or Process

1. One problem I had was _____

2. I did well on _____

3. One thing I would suggest to another student _____

4. I would like to learn more about _____

5. I could improve it by _____

PRESCRIBED LEARNING OUTCOMES

Students will...

SUGGESTIONS FOR INSTRUCTION

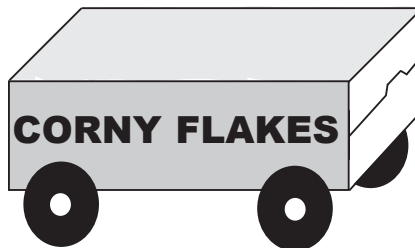

Vehicles can also be constructed from square section wood.

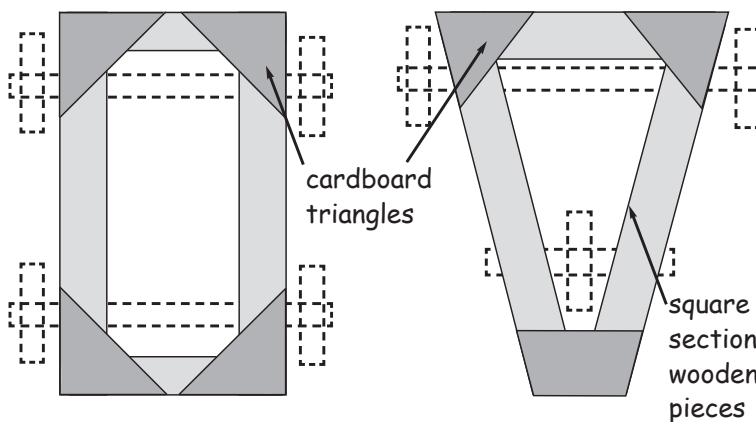

Vehicle Bodies

The body (chassis) of the constructed vehicles can be rectangular, triangular, t-shaped, etc. Cardboard triangles (purchased or home-made) provide an effective and sturdy method of joining the wooden pieces.

Wheels

There are many materials that can be used for making wheels: jar lids, cardboard disks, thread spools, thick wooden dowelling, etc. Reinforce thin wheels to prevent wobbling (Kraft stick, thick cardboard, etc.).

All wheels must be attached to the axle. The axle must be attached to the body (or chassis) of the vehicle. Axles can be made from thin wooden dowelling or even pencils. An axle holder is required to allow the axle to turn.

(continued)

TEACHER NOTES

SUGGESTIONS FOR ASSESSMENT

Square section wood is a common design construction material for students. It is similar to wooden dowelling, but is square (1 cm x 1 cm).

PRESCRIBED LEARNING OUTCOMES

Students will...

(This area is intentionally left blank for student notes.)

SUGGESTIONS FOR INSTRUCTION

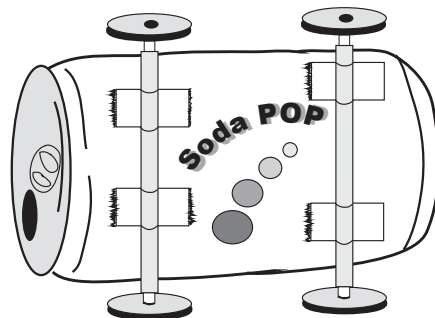

Axle Holders

The simplest type of axle holder is a tube, such as a straw, taped to the bottom of the body of the vehicle. The placement of the axle holder is important to the smooth and straight-line movement of the vehicle. Axle holders need to be parallel to the front and rear chassis of the vehicle and each other. Spacers (small pieces of plastic straw) can be used between the wheel and the body of the vehicle to allow the wheels to move freely. If the axle does not fit tightly on the wheels, a cap may be needed to prevent the wheel from falling off. Caps can be made from plasticine, rubber bands, washers, beads, etc.

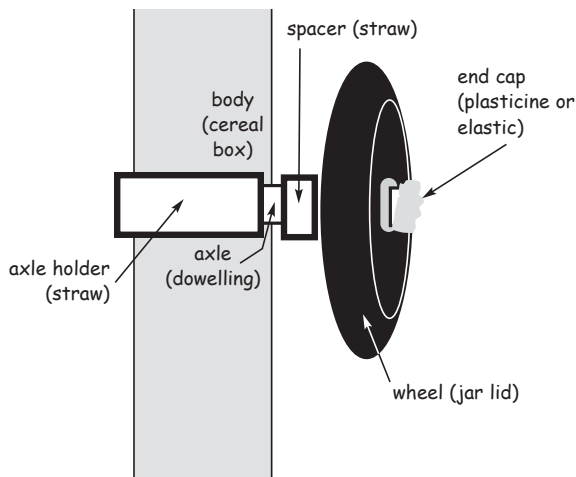

TEACHER NOTES

SUGGESTIONS FOR ASSESSMENT

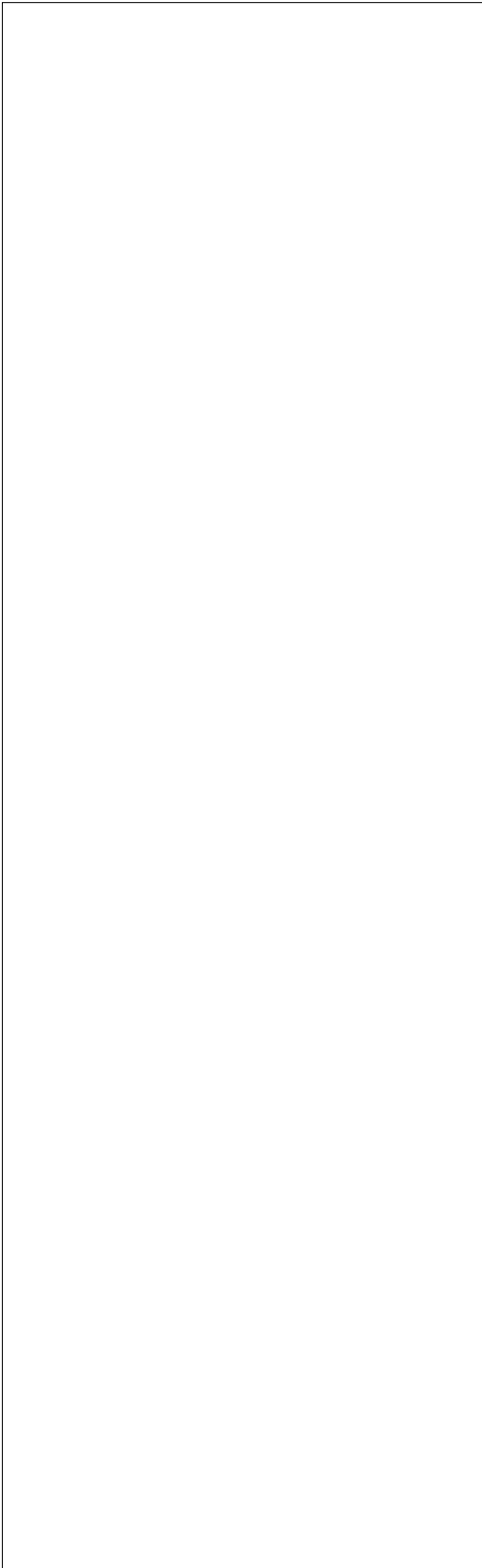

NOTES

Grade 2

Cluster 4: Air and Water in the Environment

Overview

Air and water are major parts of our physical environment and are essential for life. Yet our awareness of them is often limited, largely because we identify them only in their most obvious and observable forms. Through investigations, students learn about the characteristics of air, and the various forms of water in the environment. Students continue to build their understanding of the nature of science by describing evidence of the water cycle (see *Grade 2, Cluster 2: Properties of Solids, Liquids, and Gases*) and of moving air in indoor and outdoor environments. In the process, students discover the many ways in which air and water contribute to the health and survival of living things, including themselves.

PRESCRIBED LEARNING OUTCOMES

SUGGESTIONS FOR INSTRUCTION

Students will...

2-4-01 Use appropriate vocabulary related to their investigations of air and water.
 Include: wind, air current, temperature, changes of state, water cycle, freeze, melt, condense, evaporate, sources of drinking water, pollution.
 GLO: C6, D4, D5

➤ Introduce, explain, use, and reinforce vocabulary throughout the cluster.

2-4-02 Recognize that air can move.
 Include: wind, air current.
 GLO: D5

2-4-03 Observe and identify evidence of moving air in indoor and outdoor environments.
Examples: leaves blowing, drapes moving...
 GLO: B1, C2, D5

2-4-04 Identify positive and negative effects of changes in air temperature and air movement in indoor and outdoor environments.
 GLO: B1, E3

➤ **Activating Prior Knowledge**
 Use a KWL Strategy (Ogle, 1986) to activate prior knowledge related to wind and identify questions that students may have. The teacher should model the use of the terms “wind” and “air current” in discussions and ensure that students relate these to air movement. (Note: KWL is discussed in *ELA, Strategies*, pp. 89-92.)

➤ **Observing the Environment — Who Can See the Wind?**
 On a windy day, take a class walk to observe the effects of wind on the environment. Challenge students to find evidence that the air is moving. Students can also look for evidence of water in the environment at the same time (link to 2-4-06).

➤ **Charting Changes**
 Use a Think-Pair-Share (McTighe and Lyman, 1992) to create charts showing positive and negative effects of air temperature and movement in both indoor and outdoor environments. Have students add to their own charts when they hear new ideas. (Note: Think-Pair-Share is discussed in *ELA, Strategies*, p. 15. This strategy has been suggested throughout this cluster.)

I noticed changes	in Air Temperature	in Air Movement
When	I went into my house	I went to play in the playground
The change was	It was cooler	The wind grew stronger
Positive effects	I stopped sweating	It was better for kite flying
Negative effects	I got too cold later	The papers blew away

2-0-1a. Ask questions that lead to investigations of living things, objects, and events in the immediate environment. (ELA 1.2.4, 3.1.2, 3.1.3; Math SP-I.1.2) GLO: A1, C2, C5

2-0-5a. Make, with guidance, observations that are relevant to a specific question. GLO: A1, A2, C2

TEACHER NOTES

SUGGESTIONS FOR ASSESSMENT

Science Journal Entry: Effects of Moving Air

Have students answer the following question: How does moving air affect our lives? Provide three examples.

Look for

- wind can cool us down, blow things away, damage property, etc.
- dry clothes
- fly kites, etc.

<p>PRESCRIBED LEARNING OUTCOMES</p>
<p><i>Students will...</i></p>
<p>2-4-05 Use the design process to construct and test a device that shows evidence of air movement. <i>Examples: windsock, wind chime, pinwheel, sailboat, kite...</i> GLO: C3</p>
<p>2-0-1c. Identify practical problems to solve in the immediate environment. GLO: C3 2-0-3a. Brainstorm, with the class, possible solutions to a practical problem; and in small groups, reach consensus on a solution to implement. (ELA 1.2.3, 2.2.2) GLO: C3, C7 2-0-3b. Create, with the class, a plan to solve a problem or meet a need. <i>Examples: identify simple steps to follow, prepare a drawing of the object to be constructed...</i> (ELA 1.2.3) GLO: C3, C7 2-0-3c. Develop, as a class, limited criteria to evaluate an object or device based on its function and aesthetics. GLO: C3, C7 2-0-3d. Identify tools and materials to be used, and explain their choices. GLO: C2, C3, C4 2-0-4b. Construct an object or device to solve a problem or meet a need. GLO: C3 4c2-0- Test an object or device with respect to pre-determined criteria. GLO: C3, C5 2-0-4d. Identify and make improvements to an object or device with respect to pre-determined criteria. GLO: C3 2-0-7b. Propose a solution to the initial problem. GLO: C3 2-0-7c. Identify new problems that arise. GLO: C3</p>

SUGGESTIONS FOR INSTRUCTION

➤ **Design Project: Wind Chimes**

Have students plan and construct devices that show evidence of air movement. For example, have students construct a wind chime for themselves or for a special occasion. Let students determine the materials to be used along with a base provided by the teacher. Sample evaluation criteria might include the following:

- contains at least three different materials
- has a device that enables it to be hung up
- makes a noise in a breeze
- is aesthetically pleasing

Have students use Blackline Master 3: Design Process Recording Sheet: Grades 1 and 2.

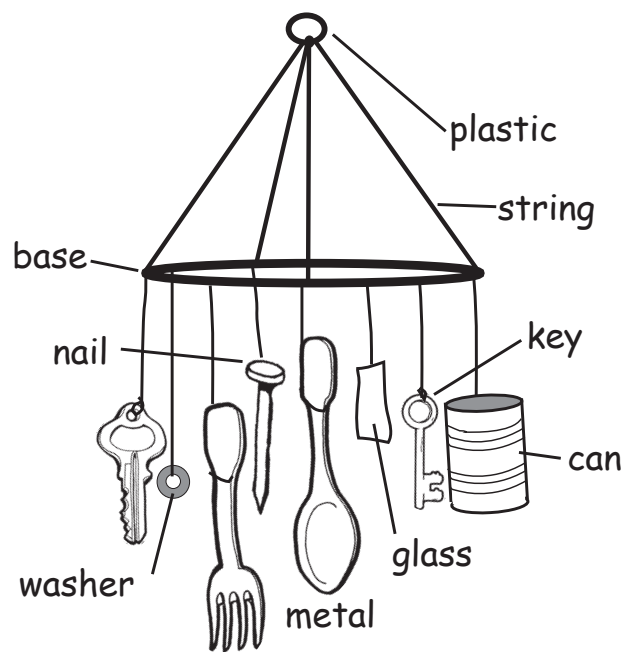

TEACHER NOTES

SUGGESTIONS FOR ASSESSMENT

Design Process Checklist

The student

- took part in the discussion
- used a variety of information sources to develop design
- worked cooperatively
- selected materials to build device
- used tools safely
- tested design with pre-determined criteria
- modified design to better meet criteria

Self-Assessment of Finished Product

How Did I Do? Answer Yes or No.

1. My device met the following criteria (example):

- contains three different materials yes ___ no ___
- has a way/device for hanging yes ___ no ___
- makes a noise in a breeze yes ___ no ___
- is nice to look at yes ___ no ___

2. I can improve my device by _____

_____.

Comments _____

_____.

PRESCRIBED LEARNING OUTCOMES

SUGGESTIONS FOR INSTRUCTION

Students will...

2-4-06 Observe and identify examples of water in the environment.
Examples: dew, frost, snow, rain, lakes, puddles, clouds, fog, perspiration...
GLO: C2, D5

2-0-2a. Access information using a variety of sources. *Examples: elders, simple chapter books, concept books, CD-ROMs, Internet...* (ELA 1.1.2, 3.2.2 Math SP-II.1.2; TFS 2.1.1) GLO: C6
2-0-2b. Match information to research needs. (ELA 3.2.3, 3.3.3) GLO: C6, C8

2-4-07 Describe evidence of water changing state, and recognize that these changes are part of the water cycle.
Examples: puddles evaporating after a rainstorm, snow melting...
GLO: D4, D5, E2, E3

2-0-1a. Ask questions that lead to investigations of living things, objects, and events in the immediate environment. (ELA 1.2.4, 3.1.2, 3.1.3; Math SP-I.1.2) GLO: A1, C2, C5
2-0-1b. Make predictions based on observed patterns or on collected data. (ELA 1.1.1, 1.2.1) GLO: A1, C2
2-0-5a. Make, with guidance, observations that are relevant to a specific question. GLO: A1, A2, C2
2-0-5c. Estimate and measure the passage of time related to minutes and hours. (Math SS-VI.1.2) GLO: C2, C3, C5
2-0-5e. Record observations using written language, drawings, and, with guidance, charts. (ELA 4.1.2, 4.2.5) GLO: C2, C6
2-0-7a. Propose an answer to the initial question based on their observations. (Math SP-IV.2.2) GLO: A1, A2, C2
2-0-7e. Describe, in a variety of ways, what was done and what was observed. *Examples: concrete materials, captioned drawings, oral language...* (ELA 4.1.2, 4.2.5) GLO: C6
2-0-8a. Recognize that learning can come from careful observations and investigations. (ELA 3.3.4) GLO: A1, A2, C2

➤ **Where’s the Water?**
Place a mirror in the freezer section of the refrigerator for five to ten minutes. Remove the mirror from the freezer and breathe on it. What forms on the mirror? Explain why.
Have students work in pairs to read and view informational texts (books, illustrations, filmstrips, videos, and CD-ROMs) to gather information about water in the environment. Have students make a picture glossary of examples in their science journals.
Use the following questions to review findings:

- In which new places did you find water?
- Does water exist in all parts of the world?
- What different forms of water did you discover existing at different times of the year?

➤ **Observing Puddles**
After a rainstorm, take the students outside to observe a puddle or pour water on the sidewalk or tarmac to create a puddle. Working in pairs, the students should make a list of everything they observe about their puddle and trace their puddle using chalk. Ask students to predict what changes they will see in their puddle when they return after two to three hours. Revisit the puddle and trace its size (if it is there at all). Have the class brainstorm possible explanations for the “disappearing puddle.” The teacher should record possible explanations and revisit these after the following demonstrations.
Math Link: Create an in-class puddle by pouring water onto acetate, or a similar plastic material. Have students trace the puddle using a marker. After wiping up the water they can cover the inside of the puddle tracing with interlocking cubes or centimetre squares to discover its area. They can go around the outside of the puddle with a piece of string and then measure the string to discover the perimeter of their puddle.

➤ **Demonstration: Cloud in a Bottle**
Pour hot water into a large jar (4 litres) and swirl it around to warm up the glass. Pour the hot water out of the jar, keeping the jar upside down to prevent any heat from escaping. Light a match or a couple of matches at once and let the smoke rise inside the jar. Quickly place the lid on the jar to trap the smoke inside.
Once the lid is on, turn the jar upright and place ice cubes on the lid. Shine a flashlight through the jar to help students observe what happens. Fog or cloud begins to form when the air near the lid starts to cool. Have students draw what they see. Ask students to explain where the cloud came from. Record possible explanations and revisit these after the next demonstration.

(continued)

TEACHER NOTES

SUGGESTIONS FOR ASSESSMENT

Dew is the moisture found on grass and other objects on the Earth’s surface in the early morning. This is replaced by **frost** in colder weather. Ensure that students identify forms of water found at different times of the year as precipitation, such as **snow, rain**, and the resulting **puddles, lakes**, or **snowbanks**. Students should also be looking to themselves for signs of **perspiration** and **water vapour** (in the breath).

Paper and Pencil Task: Where’s the Water?

Draw and label a picture to show where water is found in the environment. Include at least six different places.

Use the following checklist to assess the drawing:

- includes detail
- is labelled
- shows an understanding of the location of water in the environment
- includes six or more different places

Clouds and **fog** are made of small water droplets or tiny ice crystals that form around dust particles and float in the air. The tiny drops of water move together, forming larger, heavier drops. These water droplets are formed from water that evaporates from ponds, streams, lakes, oceans, moist plants, or soil. The evaporated water is called **water vapour**. When there is too much water vapour for the clouds to hold, the water falls as **rain, sleet**, or **snow**. The form of precipitation depends on the temperature.

PRESCRIBED LEARNING OUTCOMES

SUGGESTIONS FOR INSTRUCTION

Students will...

➤ **Demonstration: Making It Rain**

Place ice cubes on a cookie sheet for a long enough duration to make the metal cold. Hold the cookie sheet over a steaming kettle. Ask students to notice what happens when the steam from the kettle hits the cold cookie sheet. (Droplets of water form on the bottom of the cookie sheet. When the droplets of water become too heavy they fall like rain.) Have students draw what they see. Ask students to explain what happened to the water.

➤ **Where Did the Water Go?**

The class should revisit the explanations suggested for **Observing Puddles**, **Cloud in a Bottle**, and **Making It Rain** and suggest possible revisions to the original explanations. After students have made their changes, stimulate further student discussions by stating that water does not “disappear” but changes “state.” Students can help identify two states of water at this point (liquid and gas). Review the three learning experiences and trace the movement of and changes that occur to a water droplet. Pictures or words could be used to summarize as follows:

Observing Puddles: The drop started in the puddle as a liquid and then went into the air where it looked as if it disappeared as a gas.

Cloud in a Bottle: The drop started as hot water, a liquid. It went into the air as a gas. When it hit the cold lid it turned back into a water drop, a liquid.

Making It Rain: The drop started in the kettle as a liquid. When it got hot it left the kettle as steam, a gas. When it hit the cookie sheet it changed back to a liquid water drop.

➤ **Demonstration: Miniature Water Cycle**

The concept of water changing state as evidence of the water cycle can be illustrated using pop bottles. Cut the top off two two-litre plastic drink bottles and put wet sand in the bottom of one. Attach the second drink bottle with strong tape. Put the bottles on the window ledge in the sun. Identify water changing states as it goes through the water cycle.

Observe and record observations of the water cycle several times during the day, over a period of several days.

Have students record their understanding of the water cycle in their science journals by drawing and labelling a diagram.

(continued)

TEACHER NOTES

SUGGESTIONS FOR ASSESSMENT

In order for students to get the maximum benefit, demonstrations should be done in front of small groups. Other students could be working independently or in groups on centre activities, or carrying out an activity supervised by a helper.

Caution: The use of a kettle and boiling water raises safety concerns. Steps should be taken to ensure that the kettle will not be left unattended and cords are not placed where someone can trip over them.

Learning Log Entry: Water

Answer the following questions about water:

1. What do I know about water?
2. What did I learn about water today?
3. What questions would I like to ask?

Performance Task: The Water Cycle

Have students use a paper plate, markers, construction paper, cotton balls, etc. to make models/pictures of the water cycle. Students should label all parts and be able to explain their model to the class/teacher.

Scoring Rubric: The Water Cycle

- 4 water cycle model complete showing the three processes of evaporation, condensation, and precipitation; labels are correct; explanation is accurate
- 3 water cycle model shows at least two of the three processes of the cycle; labels are correct, but some may be missing; explanation demonstrates a good understanding
- 2 water cycle model shows at least two processes of the cycle; labels may be missing or incorrect; explanation shows a grade level understanding
- 1 water cycle model shows at least one process of the cycle; labels are missing or incorrect; explanation shows limited understanding and may be unclear

PRESCRIBED LEARNING OUTCOMES

SUGGESTIONS FOR INSTRUCTION

Students will...

➤ **Making Solid Water**

Working in cooperative groups, have students fill plastic cups 3/4 full of water. Have students make as many observations as they can about the water in the cups. Place the cups in a freezer overnight. Repeat observations on the contents of the cups when they come out of the freezer. Use the following headings on a chart to record both sets of observations.

1. Water Before Freezing 2. Water After Freezing

Use Think-Pair-Share (McTighe and Lyman, 1992) to have students discuss what happened to the water and predict what they think will happen if the cups are left at room temperature. Leave the cups at room temperature and have students list their observations by adding a third component to their chart such as the one below.

3. Water After Sitting In Class

2-4-08 Investigate to determine factors that cause things to dry quickly or slowly.

Examples: air temperature, amount of moisture in the air; amount of wind...

GLO: C2, D5, E3

2-0-4f. Work in a variety of cooperative partnerships and groups. (ELA 5.2.1) GLO: C7

2-0-5a. Make, with guidance, observations that are relevant to a specific question. GLO: A1, A2, C2

2-0-7a. Propose an answer to the initial question based on their observations. (Math SP-IV.2.2) GLO: A1, A2, C2

➤ **Drying Conditions**

Divide students into groups of four. In groups, have students wet four paper towels by carefully pouring approximately 25 ml of water over each one. One student should take charge of each paper towel. The first paper towel should be crumpled and set aside. The second paper towel should be held up straight without moving it. The third paper towel should be held up straight and moved gently back and forth in the air. The fourth paper towel should be held in front of a blow dryer that is set on low. When one paper towel is completely dry, students gather to compare the wetness of their four paper towels. Have students rank the towels from driest to wettest. Discuss the results. Ask students the following questions:

- Which method dried the paper towel the fastest? Why?
- Based on this experiment, would your clothes dry faster outside on the clothesline, in the drier, or hanging on a hanger in your home?
- What evidence do you have to support your prediction?
- What difference might you find if you hung your clothes outside on a hot summer day, cold windy day, and a rainy day? Why?

TEACHER NOTES

SUGGESTIONS FOR ASSESSMENT

For **Drying Conditions**, have students use Blackline Master 1: Scientific Inquiry Recording Sheet: Grades 1 and 2.

Science Journal Entry: Drying Conditions

Ask students: On which day will your clothes dry quickly? Explain how you know.

a cold, windy day

a rainy day

a hot, humid, windy day

a hot, dry, windy day

Explanation for “a hot, dry, windy day” should include the following points:

- the warmer the temperature, the faster the drying time
- the lower the moisture in the air (humidity), the faster the drying time
- moving air (wind) speeds up evaporation, therefore decreasing drying time

PRESCRIBED LEARNING OUTCOMES
<i>Students will...</i>
<p>2-4-09 Identify sources of drinking water, and explain how this water is distributed in one’s own and in other communities.</p> <p><i>Examples: wells, springs, lakes, rivers are sources; pumps, pipes, aqueducts and water trucks help distribute water...</i></p> <p>GLO: B1, D5, E2</p> <p>2-4-10 Describe different uses of water by humans.</p> <p><i>Examples: drinking, washing, cooking, canoeing, irrigating...</i></p> <p>GLO: B1</p>
<p>2-0-2a. Access information using a variety of sources. <i>Examples: elders, simple chapter books, concept books, CD-ROMs, Internet...</i> (ELA 1.1.2, 3.2.2 Math SP-II.1.2; TFS 2.1.1) GLO: C6</p> <p>2-0-7e. Describe, in a variety of ways, what was done and what was observed. <i>Examples: concrete materials, captioned drawings, oral language...</i> (ELA 4.1.2, 4.2.5) GLO: C6</p>
<p>2-4-11 Explain and appreciate the importance of clean air and water for humans, plants, and animals.</p> <p>GLO: B5, D2</p> <p>2-4-12 Identify substances that pollute air and water, and describe ways of reducing such pollution.</p> <p><i>Examples: car exhaust, smoke, carbon monoxide, oil, house paints, and sewage...</i></p> <p>GLO: B3, B5, D3, D5</p>
<p>2-0-4e. Respond to the ideas and actions of others in building their own understandings. (ELA 1.1.2) GLO: C5, C7</p>

(continued)

SUGGESTIONS FOR INSTRUCTION

➤ **Drinking Water Word Sort**

Give each student a 5 x 10 cm manila tag card. Have each student write the name of a place where he/she would find drinking water. Put the titles: “**In Nature**” and “**Human-Made**” on the board. Have the students tape their words under the correct heading. Have other cards ready for students as they brainstorm other places where they would find drinking water (water fountain, sink, lake, river, well, etc.). Add these new cards to the sorting board.

➤ **Where Does Water Come From?**

Have students listen to, read, and discuss texts that explain how water is delivered to their own and other communities. Use before, during, and after listening/reading strategies to help students increase their comprehension of concepts.

Have students work with partners to make a diagram showing how water gets from its source to their home or the school and is distributed to different rooms in the building. A visit to the mechanical room of the school or the basement in a home can help students appreciate the system of pipes needed to bring water into a home and have it available at a number of locations.

➤ **Water Uses**

With students, brainstorm and list different uses of water by humans. On a large diagram of a house, have students use pictures or words to indicate which uses for water occur in different rooms of a house.

➤ **Clean Air and Water**

- As a class, discuss the following questions:
- Why is clean air important to living things?
 - What happens to living things if the air is not clean?
 - How does air become unclean or polluted?
 - Why is clean water important for living things?
 - What happens to living things when water is not clean?
 - How does water become unclean or polluted?

➤ **Focus on Pollution**

With students, brainstorm and list causes of air pollution and water pollution. Have students work in pairs to suggest ways to reduce this pollution. Have students reach consensus and record their prevention measures.

(continued)

TEACHER NOTES

The City of Winnipeg, Water and Waste Department publishes pamphlets and an education program related to water and water conservation. For more information telephone (204) 989-8355. See the References section for more information.

SUGGESTIONS FOR ASSESSMENT

Paper and Pencil Task: Water Uses

Have students design/create a web or mind map to show how humans use water. Example:

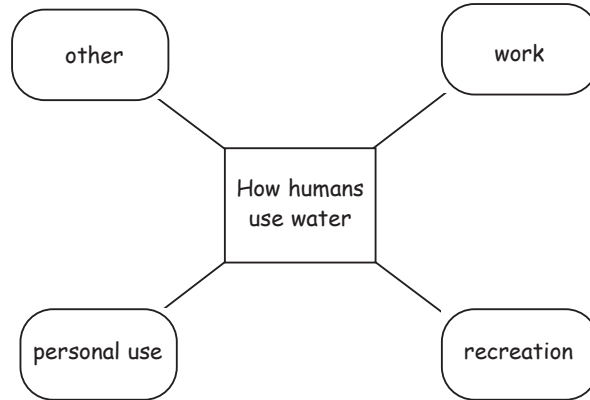

Mind Map/Web Checklist: Water Uses

The student demonstrates an understanding of water use by including examples of

- personal use
- recreational use
- work-related use
- other

Science Journals: Clean Air and Water

Have students respond to the following prompts in their science journals.

I think clean air is important to living things because:

1. _____
2. _____

I think clean water is important to living things because:

1. _____
2. _____

PRESCRIBED LEARNING OUTCOMES

SUGGESTIONS FOR INSTRUCTION

Students will...

2-0-4g. Verbalize questions, ideas, and intentions during classroom activities. GLO: C6
2-0-7e. Describe, in a variety of ways, what was done and what was observed. *Examples: concrete materials, captioned drawings, oral language...* (ELA 4.1.2, 4.2.5) GLO: C6

➤ **Radio or Television Commercials**

Have students work in pairs to write slogans for television or radio commercials that promote the ideas of reducing pollution and keeping the environment clean. For example: Toss your garbage in the trash. Don't pour paint into the grass. Stop: don't pour oil in the sewer.

2-4-13 Recognize that clean water is an increasingly scarce resource in many parts of the world, and describe consequences of a shortage of clean water.
 GLO: B1, B3, B5

➤ **The Wealth of Water**

Have students listen to, read, and view pictures, magazines, newspaper articles, and video clips showing the scarcity of water in many parts of the world. Identify how a shortage of water might have an impact upon daily life, e.g., washing, drinking, bathing, crops, etc.

2-0-2a. Access information using a variety of sources. *Examples: elders, simple chapter books, concept books, CD-ROMs, Internet...* (ELA 1.1.2, 3.2.2 Math SP-II.1.2; TFS 2.1.1) GLO: C6
2-0-9a. Willingly consider other people's views. GLO: C5, C7

2-4-14 Record personal use of water, and identify ways in which they can reduce water usage.
Examples: rather than leaving water running while brushing teeth, turn off tap to reduce usage...
 GLO: B5, C2, C5

➤ **Water Diary**

Give each student a chart such as the one below to record their personal use of water for the day. Students use a tally mark every time they use water.
 Math Link: The following day, when the chart is completed, ask students to tally and graph their results.
 Have students use a chart similar to the one shown below.

Personal Use Chart

Water Use	At School	At Home	Other
Bathroom	✓✓✓	✓✓	✓
Washing	✓	✓✓✓	
Brushing teeth		✓✓✓✓	✓
Recreation		✓	✓
Drinking	✓✓✓✓	✓✓	✓

2-0-5e. Record observations using written language, drawings, and, with guidance, charts. (ELA 4.1.2, 4.2.5) GLO: C2, C6
2-0-6a. Construct and label concrete-object graphs, pictographs, and bar graphs using 1:1 correspondence. (Math SP-III.2.2) GLO: C2, C6
2-0-7d. Connect new experiences, ideas, and information with prior knowledge and experiences. (ELA 1.2.1, 2.1.2) GLO: A2

➤ **Water Conservation Posters**

As a class, review personal-use charts and brainstorm ways in which students can reduce the amount of water they use (e.g., turn off the tap when brushing their teeth, have shorter showers, don't fill the bathtub to the top, set a timer when watering the garden, fix dripping faucets, etc.). Have each student select one conservation method and make a poster to illustrate it.

TEACHER NOTES

SUGGESTIONS FOR ASSESSMENT

Household Water Use in Manitoba*

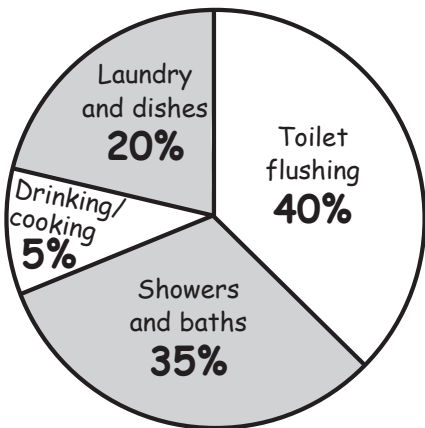

* Source: *The Manitoba Clean Water Guide*, p. 14. Reproduced with permission of Manitoba Environment, 1999.

Paper and Pencil Task: Water Waste

Have students examine the pictures and describe how water is being wasted. Ask students how the waste can be reduced.



NOTES

Grade 3 Science

Grade 3

Cluster 1: Growth and Changes in Plants

Overview

In Grade 3, the study of living things focusses on the characteristics and needs of plants and their growth patterns. Students observe and investigate local plants, but a deeper understanding and appreciation is developed through planting, nurturing, and observing individual plants over time. Connections are made to students' prior knowledge of animal needs (see *Grade 2, Cluster 1: Growth and Changes in Animals*) by identifying needs that are similar between plants and animals and how those needs are met. This cluster addresses the importance of plants to the environment as well as the significance of food, shelter, medicine, and other plant products to humans. Emphasizing the connection between this cluster and *Grade 3, Cluster 4: Soils in the Environment* develops the relationship between plants and the soils in which they are grown.

PRESCRIBED LEARNING OUTCOMES

SUGGESTIONS FOR INSTRUCTION

Students will...

3-1-01 Use appropriate vocabulary related to their investigations of growth and changes in plants.

Include: growing medium, nutrient, energy, root, stem, leaf, flowers, pistil, stamen, ovule, pollen, seed, fruit, adaptation, life cycle.

GLO: C6, D1

➤ Introduce, explain, use, and reinforce vocabulary throughout this cluster.

➤ **Word Cycle**

Teach students how to use a word cycle to help them become familiar with the specific vocabulary related to the learning outcomes in this cluster. Use the word cycle to assess students' knowledge of terms studied in specific sections of this cluster (see *Success for All Learners*, 6.31).

3-1-02 Observe, compare, and contrast the structure and appearance of several types of plants.

Examples: plants with different types of roots, trees with needles and trees with leaves...

GLO: C2, D1, E1

➤ **Plant Etiquette**

Discuss and develop a list of guidelines and safety procedures to follow to ensure students show respect for plants as living things. Guidelines might include: avoid trampling on plants, touch plants only after an adult has given permission, touch and bend the plant gently to avoid damage, observe using sense of sight and sense of smell before using sense of touch, etc.

3-1-03 Show respect for plants as living things.

GLO: B5

➤ **Compare and Contrast**

Set up a plant observation centre where students sort and classify plants. Have students explain the method used and then resort and relabel the groups. Plants should be provided that show a variety of roots, leaves, flowers, and seeds.

3-0-4h. Follow given safety procedures and rules, and explain why they are needed. GLO: C1

3-0-5a. Make observations that are relevant to a specific question. GLO: A1, A2, C2

3-0-5b. Use tools to observe, measure, and construct. Include: ruler, metre stick, pan balance, magnifying glass, bathroom scale, thermometer, magnet. (Math SS-I.1.3, SS-III.1.3, SS-IV.1.3, SS-VII.4.3) GLO: C2, C3, C5

3-0-6c. Place materials and objects in a sequence or in groups using two or more attributes, and describe the system used. (Math PR-I.1.3) GLO: C2, C3, C5

➤ **Venn Comparison: Plants**

In small groups, have students select two plants to compare and contrast using a Venn diagram. Students may prefer to draw the parts of each plant to show the differences.

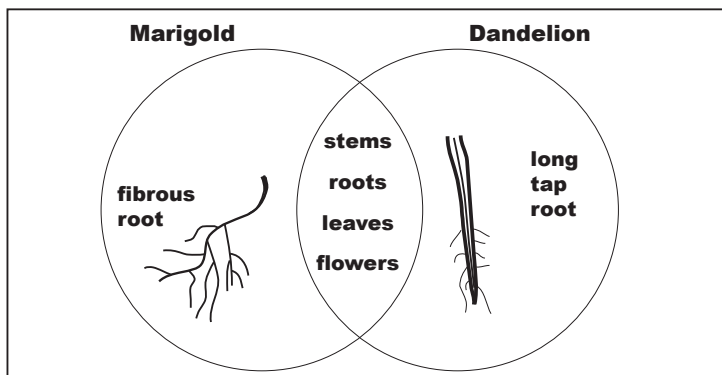

➤ **Art Connection**

Have students sketch a plant and/or press a plant to make an environmental note card.

TEACHER NOTES

SUGGESTIONS FOR ASSESSMENT

Cluster Note: Students’ achievement of the learning outcomes in this cluster is dependent on having adequate time to conduct experiments on plant growth and to follow a flowering plant through a complete life cycle.

Caution: Ensure that there are no dangerous plants such as poison ivy or poison berries in your local area. Check to make sure that there are no students with plant allergies in your class. (Refer to *Success for All Learners*, 9.5 for details on conducting an ecology walk.)

Have a plant collection already prepared to ensure a wide variety. Students could participate in making plant collections. Alternatives to live plant collections include pictures of plants.

When discussing the Venn diagram introduce the related vocabulary.

Science Journal Entry: Plant Etiquette

Directions to students: In your science journals, finish the following sentence:

I can show respect for plants as living things by _____.

List as many examples as you can.

Look for

- examples related to avoiding damage to plants
- references to safety issues

Student Self-Assessment: Plants

Directions to students: At the plant observation centre you will be comparing plants to determine how they are the same and how they are different. Use this checklist to check your observation skills.

Checklist: How Are My Observation Skills?

I used the following senses to observe:

- sight smell touch hearing

I used the following tools:

- magnifying glass
- centimetre ruler
- other _____

I observed the following properties:

- colour shape texture size

I also observed _____

PRESCRIBED LEARNING OUTCOMES	SUGGESTIONS FOR INSTRUCTION
<p><i>Students will...</i></p>	
<p>3-1-04 Conduct experiments to determine conditions needed for healthy plant growth. Include: light, water, air, space, warmth, growing medium, nutrients. GLO: A1, C2, C5, D1</p> <p>3-1-05 Recognize that a plant uses the Sun’s energy to make its own food. GLO: D1, D2, D4, E4</p>	<p>➤ Investigating Conditions for Healthy Plant Growth</p> <p>To determine students’ prior knowledge (related to the learning outcomes), ask students the following question: What do you think plants need to survive?</p> <p>Discuss with students how to test to determine which conditions are necessary for plant growth. Decide as a class the best procedure to use in conducting the experiment, the materials required, and how to record the observations.</p> <p>This investigation will take place over a two- to three-week period. Ensure that only one variable is changed at a time and that all other conditions remain constant. Include the variables light, water, air, space, warmth, growing medium, and nutrients. Each group of students will be responsible for one of the conditions and must ensure that all the other conditions are kept constant.</p> <p>Have students make predictions about which plants they think will grow best and why.</p> <p>Have students record their observations about each condition in their science journals. Encourage students to take pictures of their group’s plant growth. Have students use Blackline Master 2: Scientific Inquiry Recording Sheet: Grades 3 and 4.</p> <p>At the end of the experiment, have students present their findings to the class. Students can scan pictures, create slide shows, or use software to create multimedia presentations.</p>
<p>3-0-1b. Make predictions based on observed patterns, collected data, or data provided from other sources. (ELA 1.1.1; Math SP-IV.2.3) GLO: A1, C2</p> <p>3-0-3a. Brainstorm, with the class, one or more methods of finding the answer to a given question and reach consensus on which method to implement. GLO: C2, C7</p> <p>3-0-3b. Identify, with the class, variables that have an impact on an investigation. GLO: A1, A2, C2, C7</p> <p>3-0-3c. Create, with the class, a plan to answer a given question. (ELA 3.1.4) GLO: C2, C7</p> <p>3-0-4a. Carry out a plan, and describe the steps followed. (Math SP-V.2.3) GLO: C2</p> <p>3-0-5a. Make observations that are relevant to a specific question. GLO: A1, A2, C2</p> <p>3-0-5b. Use tools to observe, measure, and construct. Include: ruler, metre stick, pan balance, magnifying glass, bathroom scale, thermometer, magnet. (Math SS-I.1.3, SS-III.1.3, SS-IV.1.3, SS-VII.4.3) GLO: C2, C3, C5</p> <p>3-0-5c. Estimate and measure mass/weight, length, volume, and temperature using standard units. (Math SS-IV.1.3, SS-I.1.3, SS-III.1.3, SS-VIII.4.3) GLO: C2, C3, C5</p> <p>3-0-5e. Record observations in a variety of ways. <i>Examples: point-form notes, sentences, simple diagrams, charts...</i> (ELA 3.2.1, 3.3.2, 4.1.3; Math SP-II.2.1, SP-V.2.3) GLO: C2, C6</p> <p>3-0-7a. Draw a simple conclusion based on their observations. GLO: A1, A2, C2</p> <p>3-0-7b. Explain why conclusions related to classroom experiments should be based on multiple trials or classroom data rather than on an individual result. GLO: A1, A2, C2</p> <p>3-0-7d. Examine how new experiences, ideas, and information connect to prior knowledge and experiences, and record these connections. (ELA 1.2.1, 2.1.2, 3.3.3) GLO: A2, C6</p> <p>3-0-7e. Communicate results and conclusions in a variety of ways. <i>Examples: point-form lists, sentences, simple diagrams, charts, demonstrations...</i> (ELA 2.3.5, 3.3.2, 4.1.3; Math SP-III.2.3; TFS 2.1.4) GLO: C6</p>	<p>➤ Math Connection</p> <p>Have students measure plant growth, count leaves, record their data, display their data, and formulate questions to assist in other data collection strategies.</p>

TEACHER NOTES

SUGGESTIONS FOR ASSESSMENT

Beans will sprout within a week and can be sprouted in a clear plastic bag. Popcorn also sprouts easily. Marigolds take longer but will produce a flowering plant (see outcomes 3-1-10, 3-1-4).

If the experiments include growth in different types of soil, then outcome 3-4-07 can be addressed here.

Sunlight provides the plant with energy to change carbon dioxide and water into the food substances (sugars) they need. This process is called photosynthesis. **Water** carries nutrients and moisture that the plant requires to make its own food.

Carbon dioxide is required as air for the plants. Plants release oxygen into the air. Plants require ample **space** to grow so that they acquire enough water and can get enough sunlight. Plants need **soil** containing the proper **nutrients** in order to produce their own food.

In experiments it is important to control **variables**. A variable is an object, or quantity that can change. For example, if students are going to test the impact of sunlight on plant growth, they need to ensure that all the other variables such as water, space, warmth, growing medium, etc., are exactly the same for all plants, so that any changes in the plant can be attributed to different amounts of sunlight.

Performance Task

Say to students: You have been given a new plant for your bedroom. How will you make sure that it remains healthy and grows? Be sure to include as much detail as possible.

Scoring Rubric

- 4 Student work demonstrates a solid understanding of the conditions needed for healthy plant growth. At least six conditions are given (light, water, air, space, warmth, growing medium, nutrients). Explanation is clear and complete.
- 3 Student work demonstrates a good understanding of the conditions needed for healthy plant growth. Four or five conditions are given. Explanation is clear.
- 2 Student work demonstrates a basic understanding of the conditions needed for healthy plant growth. Three or four conditions are given. Explanation is unclear or incomplete.
- 1 Student work demonstrates a limited understanding of the conditions needed for healthy plant growth. Two conditions are given. Explanation is unclear or missing.

PRESCRIBED LEARNING OUTCOMES	SUGGESTIONS FOR INSTRUCTION
<p><i>Students will...</i></p>	
<p>3-1-06 Use the design process to construct an environment that enhances plant growth.</p> <p><i>Examples: window sill garden, terrarium, cold frames...</i></p> <p>GLO: A5, C3, C5, D1</p>	<p>➤ Design an Ideal Growing Environment</p> <p>Challenge students to design an ideal growing environment for plants. Provide a context for the design activity. The context can come from a related literature piece or from a specific need such as a school foyer plant-growing area. Although there are numerous resources that describe how to build a terrarium, a windowsill garden, and a cold-frame, it is important for students to use the design process to plan, construct, and evaluate their own designs. Designs could include a self-watering system, or a plant-turning system to keep plants facing the sun.</p> <p>Have students use Blackline Master 4: Design Process Recording Sheet: Grades 3 and 4.</p>
<p>3-0-1c. Identify practical problems to solve in the local environment. GLO: C3</p> <p>3-0-2a. Access information using a variety of sources. <i>Examples: children’s magazines, local farmers, CD-ROMs, Internet...</i> (ELA 1.1.2, 3.2.2; Math SP-I.1.2.3; TFS 2.1.1) GLO: C6</p> <p>3-0-3d. Brainstorm, in small groups, possible solutions to a practical problem, and reach consensus on which solution to implement. GLO: C3, C7</p> <p>3-0-3e. Create, in small groups, a written plan to solve a problem or meet a need. Include: identify steps to follow, prepare a simple diagram. (ELA 1.2.3) GLO: C3, C7</p> <p>3-0-3f. Develop, in small groups, limited criteria to evaluate an object or device based on its function and aesthetics. GLO: C3, C7</p> <p>3-0-4b. Construct an object or device to solve a problem or meet a need. GLO: C3</p> <p>3-0-4c. Test an object or device with respect to pre-determined criteria. GLO: C3, C5</p> <p>3-0-4d. Identify and make improvements to an object or device, and explain the rationale for the changes. GLO: C3</p> <p>3-0-4h. Follow given safety procedures and rules, and explain why they are needed. GLO: C1</p> <p>3-0-5b. Use tools to observe, measure, and construct. Include: ruler, metre stick, pan balance, magnifying glass, bathroom scale, thermometer, magnet. (Math SS-I.1.3, SS-III.1.3, SS-IV.1.3, SS-VII.4.3) GLO: C2, C3, C5</p> <p>3-0-7c. Identify new problems that arise. GLO: C3</p> <p>3-0-8c. Recognize that designing a solution to a simple problem may have considerations, such as cost, materials, time, and space. GLO: B2, C3</p>	

TEACHER NOTES

SUGGESTIONS FOR ASSESSMENT

Observation Checklist: Design an Ideal Growing Environment

The student

- willingly participates in brainstorming possible solutions
- researches ideas using a variety of sources
- creates a written plan/diagram
- works with a group to develop criteria
- constructs the growing environment
- tests the growing environment
- makes improvements to the growing environment
- communicates results

Group Assessment: Design an Ideal Growing Environment

How Did We Work?

Group Members

Comments

Listened to the ideas of others _____

Shared the work _____

Encouraged other group members _____

Worked cooperatively _____

Stayed on task _____

Followed safety procedures/rules when using materials/tools _____

Next time we should _____

PRESCRIBED LEARNING OUTCOMES	SUGGESTIONS FOR INSTRUCTION
<p><i>Students will...</i></p>	
<p>3-1-07 Identify the basic parts of plants and describe their functions. Include: roots, stems, leaves, flowers, pistil, stamen, ovule, pollen, seeds, fruit. GLO: D1, E2</p>	<p>➤ Plant Observations Provide plant samples for students to observe. Have them identify the basic parts. Focus students’ observations by posing these questions:</p> <ul style="list-style-type: none"> • What are the basic parts of a plant? • What is the function (purpose) of each part? <p>Have students sketch their plant and label its main parts. Drawings should include roots, stems, leaves, flowers/seeds/fruit.</p>
<p>3-0-2a. Access information using a variety of sources. <i>Examples: children’s magazines, local farmers, CD-ROMs, Internet...</i> (ELA 1.1.2, 3.2.2; Math SP-I.1.2.3; TFS 2.1.1) GLO: C6 3-0-2b. Review information to determine its usefulness to research needs. (ELA 3.2.3, 3.3.3) GLO: C6, C8</p>	<p>➤ Plant Discovery: Stems Carry Nutrients Divide students into groups. Provide each group with a cup, water, food colouring, and a stalk of celery or a white carnation. Have students colour the water with food colouring and then place the celery or the carnation in the water, and observe what happens. The coloured water travels to the top, changing the colour of the leaves or flower. This helps to demonstrate that one purpose of the stem is to carry nutrients from the soil to the leaves and flowers.</p>
	<p>➤ Plant Discovery: Leaves Give off Oxygen Put leaves upside down in a clear bowl filled with water. Shine a bright light on the leaves. Have students observe bubbles forming on the leaves. The bubbles are escaping oxygen.</p> <p>➤ Flower Power Have students use videos, CD-ROMs, etc., to identify and describe the purpose of the flower, pistil, stamen, ovule, pollen, seeds, and fruit. Model notetaking during the viewing process.</p>
<p>3-1-08 Explain how different adaptations of plants help them survive in particular environments. <i>Examples: cacti have fleshy stems that store water, allowing them to survive in a dry environment; plants with tap roots can grow well in heavily compacted soil...</i> GLO: D1, D2, E1 3-1-09 Identify plant adaptations that can be harmful to humans, and describe their effects. (continued)</p>	<p>➤ Weed Pull If possible, have students participate in weeding the school flower bed or lawn. Weeds would need to be clearly identified beforehand. Students will need close supervision for this activity and should wear protective gear. Following the weed pull, ask students the following questions:</p> <ul style="list-style-type: none"> • Were the weeds easy to pull or difficult? • What parts of the weeds make them able to spread easily? Why? <p>➤ Plant Adaptation Research Have students find answers to the following questions:</p> <ul style="list-style-type: none"> • How are plants adapted to extreme environments (very hot, cold, wet, or dry)? • In what ways do plants protect themselves? • Which plant adaptations cause harm to humans? <p>(continued)</p>

TEACHER NOTES

SUGGESTIONS FOR ASSESSMENT

Plant Parts

The **roots** are used to: anchor the plant in the soil, bring water and nutrients to the stem, and sometimes store food (e.g., carrot). **Stems** are used to: support the upper part of the plant, carry water and dissolved nutrients to the leaves, and store food. **Leaves** produce the food for the plant through a process called photosynthesis. **Flowers** are the reproductive part of the plant. The **pistil** is the part of the flower that produces the seeds. The **stamen** is the part of the flower that contains the pollen. The stamen is surrounded by the petals. The **ovule** is the part of the plant that develops into the seed. **Pollen** is the yellowish powder that forms in flowers. Grains of pollen carried to the pistils of flowers fertilize them. The seeds contain the embryo for the new plant. The fruit contains the seeds. It is the ripened ovule.

Paper and Pencil Task: Plant Observations

Student directions:

1. Draw a diagram of a flowering plant and label its parts.
2. Explain how each of these parts helps the plant

roots _____
 stems _____
 leaves _____
 flowers _____
 pistil _____
 stamen _____
 ovule _____
 pollen _____
 seeds _____
 fruit _____

For the assessment of outcomes 3-1-07 to 3-1-09, see **Student Interview** opposite outcome 3-1-11.

Discover Agriculture Science Curriculum Activities, “Grade 5 Lesson Two — Adaptations of Plants,” contains easily adaptable material suitable to address this outcome, with diagrams of common food plants, including the roots. “Lesson Three — Weeds,” addresses the structural adaptations of weeds that make them problematic for farmers. (See the References section for a full citation.) Contact Agriculture in the Classroom, telephone: (204) 487-4029, for further information about materials and speakers.

PRESCRIBED LEARNING OUTCOMES

Students will...

Examples: rose thorns cause painful punctures, poison in rhubarb leaves can cause sickness and death...

GLO: B3, C1, D1

3-0-4a. Carry out a plan, and describe the steps followed. (Math SP-V.2.3) GLO: C2

3-0-5e. Record observations in a variety of ways. *Examples: point-form notes, sentences, simple diagrams, charts...* (ELA 3.2.1, 3.3.2, 4.1.3; Math SP-II.2.1, SP-V.2.3) GLO: C2, C6

3-1-10 Care for a flowering plant throughout its life cycle, tracking its growth and its changes over time.

GLO: B5, C5, D1, E3

3-1-11 Identify characteristics that remain constant and those that change throughout the life cycle of a flowering plant.

Examples: generally, for a given plant, the leaf shape and flower colour stay the same, whereas the leaf size and number of leaves change...

GLO: D1, E3

3-0-4e. Respond respectfully to the ideas and actions of others, and recognize their ideas and contributions. (ELA 1.1.2, 5.2.2) GLO: C5, C7

3-0-5a. Make observations that are relevant to a specific question. GLO: A1, A2, C2

3-0-7e. Communicate results and conclusions in a variety of ways. *Examples: point-form lists, sentences, simple diagrams, charts, demonstrations...* (ELA 2.3.5, 3.3.2, 4.1.3; Math SP-III.2.3; TFS 2.1.4) GLO: C6

3-1-12 Identify needs common to plants and animals, and contrast how they meet those needs.

GLO: D1, E1

(continued)

SUGGESTIONS FOR INSTRUCTION

Have students work individually or with a partner to research information regarding plant adaptations.
Have students present information in the form of integrated text.

Plant	Adaptation
rhubarb	poisonous leaves
cacti	water-retentive stem and spines
oak tree	hard bark, strong and long taproot
Canada thistle	deep root, prickly leaves, produces milk
rose	thorns, pleasant scent
dandelion	parachute seeds, grow anywhere
sedges	wedge-shaped stem to cut the wind, etc.

➤ **Observing Plant Life Cycles**

Use the activity **Investigating Conditions for Healthy Plant Growth** (3-1-04 and 3-1-05). Have students continue their observations until plants reach maturity. Discuss observations and focus discussions on the plants in the control group.

Ask students these questions about the plant life cycles:

- What changes happened to the plant?
- When did the plant grow the most?
- How long did it take the plant to flower?
- What do the seeds look like?
- What parts of the plant are the same throughout the life cycle? (leaf shape)
- What parts of the plant changed throughout the life cycle? (roots grew, stem grew, leaves grew, flowers formed, seeds formed, etc.)

➤ **Art Connection: Flower Printing**

Take a leaf or flower and lay it between a piece of fabric (bottom) and wax paper (top). Use a non-synthetic fabric. Pound the flower or leaf reasonably hard with a hammer so it is imprinted on the fabric. Soak in cold water to set it.

➤ **Identifying Needs**

Use a Focused Free Write to activate and extend students' prior knowledge regarding the basic needs of living things and how they meet those needs (see *Grades 1 and 2, Cluster 1*). (Note: the Focused Free Write is discussed in *Success for All Learners*, 6.30.)

(continued)

TEACHER NOTES	SUGGESTIONS FOR ASSESSMENT
<p>Plant Life Cycles Amaryllis bulbs work well for observing a complete life cycle. Bean plants will also work but require manual pollination using a cotton swab.</p>	<p>Student Interview for Outcomes 3-1-07 to 3-1-11 Before the interview, gather/prepare the following materials: pictures of three different plants such as cactus, dandelion, coniferous tree; and a series of pictures depicting the life cycle of a flowering plant. Ask students the following questions:</p> <ol style="list-style-type: none">1. What are the basic parts of a plant and what does each part do? <input type="checkbox"/> root <input type="checkbox"/> stem <input type="checkbox"/> leaves <input type="checkbox"/> flowers <input type="checkbox"/> pistil <input type="checkbox"/> stamen <input type="checkbox"/> ovule <input type="checkbox"/> pollen <input type="checkbox"/> seeds <input type="checkbox"/> fruit2. Here are three different plants. Can you tell how each of these plants is adapted to its environment?3. Arrange these pictures in order to show the life cycle of this plant.4. What characteristics stay the same over this plant's life cycle?5. What characteristics change over this plant's life cycle? <p>Record student responses. Note any misconceptions or gaps in their learning.</p>

PRESCRIBED LEARNING OUTCOMES	SUGGESTIONS FOR INSTRUCTION
<p><i>Students will...</i></p> <p>3-0-7e. Communicate results and conclusions in a variety of ways. <i>Examples: point-form lists, sentences, simple diagrams, charts, demonstrations...</i> (ELA 2.3.5, 3.3.2, 4.1.3; Math SP-III.2.3; TFS 2.1.4) GLO: C6</p>	<p>➤ Three Differences</p> <p>Have students identify three main differences between the ways in which plants and animals each meet their needs. Example: plants must wait for rain or send roots deep into the soil to reach water; animals can move to where there is a stream or pond.</p> <p>➤ Presentations</p> <p>Have students write a poem, chant, or rap to remember the needs of living things and how plants and animals meet these needs in different ways.</p>
<p>3-1-13 Describe ways that plants and animals depend on each other.</p> <p><i>Examples: plants provide food and shelter for some animals, animals help distribute pollen and seeds...</i></p> <p>GLO: D2, E2</p> <p>3-1-14 Describe ways plants are important to the environment.</p> <p><i>Examples: improve soil, air, and water quality; reduce erosion...</i></p> <p>GLO: B5, D2</p>	<p>➤ Group Inquiry — I Chart</p> <p>Guide the students through an inquiry regarding the interdependence of plants and animals by using an I Chart (Hoffman, 1992). (See <i>ELA, Strategies</i>, pp. 83-87.)</p> <p>Use the following questions to focus students’ research:</p> <ul style="list-style-type: none"> • How do plants help animals survive? • How do animals help plants survive? <p>➤ The Day All the Plants Disappeared</p> <p>Have students write a story describing what the world would be like without plants. Examples: the impact on animals, people, the environment.</p>
<p>3-0-2a. Access information using a variety of sources. <i>Examples: children’s magazines, local farmers, CD-ROMs, Internet...</i> (ELA 1.1.2, 3.2.2; Math SP-I.1.2.3; TFS 2.1.1) GLO: C6</p> <p>3-0-2b. Review information to determine its usefulness to research needs. (ELA 3.2.3, 3.3.3) GLO: C6, C8</p> <p>3-0-4g. Verbalize questions, ideas, and intentions during classroom-learning experiences. GLO: C6</p>	<p>➤ Sketch to Stretch</p> <p>Have students draw pictures of the Earth without plants using a Sketch to Stretch strategy (Short, Harste, Burke, 1996). (See <i>ELA, Strategies</i>, p. 209.)</p> <p>Have each student write an explanation about how the lack of plants has an impact on other living things. Include the role plants play in relation to soil, air, water quality, and erosion. Tie this in with <i>Cluster 4: Soils in the Environment</i> to learn about soil enrichment.</p>
<p>3-1-15 Identify and describe hobbies and jobs involving plants.</p> <p>GLO: B4</p> <p>3-1-16 Identify how humans from various cultures use plant parts for food and medicine.</p> <p><i>Examples: use of roots for food (carrots) and medicine (ginseng)...</i></p> <p>GLO: A4, B1, C5, E1</p> <p style="text-align: right;">(continued)</p>	<p>➤ Brainstorming Hobbies and Jobs</p> <p>With students, brainstorm to list jobs and hobbies related to plants. Post the list in the classroom and allow students to add to the list as they learn about other jobs and hobbies related to plants.</p> <p>From the list, invite a guest speaker (gardener, botanist, farmer, lumber miller, paper maker, fabric maker, doctor, artist, traditional healer, etc.).</p> <p>Help students develop appropriate interview questions.</p>

TEACHER NOTES

SUGGESTIONS FOR ASSESSMENT

The Manitoba Fisheries website provides teacher background information and instructional suggestions related to how plants help fish. The website is located at <<http://www.gov.mb.ca/natres/sustain/index.html>>

Checklist: The Day All the Plants Disappeared

Story includes:	Impact on animals	Impact on people	Impact on environment	Other	Comments
Student's Name					

Contact your local Manitoba Agriculture office for further information regarding speakers.

PRESCRIBED LEARNING OUTCOMES	SUGGESTIONS FOR INSTRUCTION
<p><i>Students will...</i></p>	
<p>3-1-17 Investigate to determine how humans from various cultures make useful products from plant materials. <i>Examples: lumber milling, paper making, rope making, fabric making...</i> GLO: A3, A4, B1</p> <p>3-1-18 Explain how humans replenish the plants they use and the consequences if plants are not replenished. <i>Examples: after loggers harvest trees, new ones should be planted to ensure a future lumber supply...</i> GLO: B1, B5, E3</p>	<ul style="list-style-type: none"> ➤ Collage Have students work in small groups to create a collage illustrating how various cultures use plants to make many different products. ➤ Research: Plant Uses in Various Cultures Have students investigate the traditional use of a plant for food or medicine. ➤ Making Paper Use a simple paper-making process (soaking scraps, straining on screens, and drying) to make paper. Explore paper-making using vegetable scraps, flowers, etc. ➤ Reforestation Watch a video on reforestation. Have students use their science journals to reflect on why it is important to plant trees to replace those that are harvested or destroyed by fire, etc.
<p>3-0-4f. Assume roles and share responsibilities as group members. (ELA 5.2.1) GLO: C7</p> <p>3-0-9a. Listen to and consider differing opinions. (ELA 5.2.3) GLO: C5, C7</p> <p>3-0-9b. Express enjoyment when sharing and discussing science-related experiences from daily life. (ELA 4.4.3) GLO: C5</p>	

TEACHER NOTES

SUGGESTIONS FOR ASSESSMENT

Paper and Pencil: Cluster Reflection

Complete the following statements:

1. In order to grow, plants need

2. Plant adaptations help a plant by

3. Two ways plants and animals meet their needs differently are

4. Three things that can be made from plants are

5. Plants are important to people and the environment because

6. One thing I liked

NOTES

Grade 3

Cluster 2: Materials and Structures

Overview

Students learn about the nature of materials not just by observing them but, more importantly, by using them. In this cluster, students experience the design process as they manipulate and test materials, build structures, and select and use materials suitable to the task at hand. Students find that the strength and stability of structures in their community, as well as those they build themselves, are linked to the properties of the materials used and to the particular way the materials are configured and joined. This cluster further develops the concept of materials introduced in *Kindergarten, Cluster 3: Paper* and built upon in *Grade 1, Cluster 3: Characteristics of Objects and Materials*.

PRESCRIBED LEARNING OUTCOMES

SUGGESTIONS FOR INSTRUCTION

Students will...

3-2-01 Use appropriate vocabulary related to their investigations of materials and structures.

Include: strength, balance, stability, structure, frame structure, natural structure, human-built structure, force.

GLO: C6, D3

➤ Introduce, explain, use, and reinforce the vocabulary throughout the cluster.

3-2-02 Conduct experiments to compare the strength of common materials.

Examples: wooden toothpicks, plastic straws, paper, cardboard, polystyrene foam...

GLO: A1, A2, C2, D3

3-2-03 Explore to determine ways to strengthen a material used for building.

Include: changing shape, bulk, and number of layers.

GLO: B1, C2, D3

➤ **Gaining Student Interest**

Ask students the following questions:

- Why are certain materials selected or rejected for building structures?
- How can the strength of some materials be increased?

➤ **Sorting Objects by Strength**

Provide a variety of materials for students to sort according to strength. Include toothpicks, spaghetti, popsicle sticks, straws, and an assortment of paper and polystyrene foam. Have students predict material strength by listing materials in order of strength from weakest to strongest.

➤ **Investigating Materials for Strength**

Brainstorm, with the class, several methods for comparing the strength of various materials. Have students identify variables that will affect the investigations. For example: use similar amounts of the various materials in the test. As a class, create a plan for each method of investigation. In small groups, have students: carry out the investigations, record the steps they followed, and record their observations and the conclusions based on their results. Example of a sample method: Use various materials to make bridges and test each with various weights or objects.

3-0-1b. Make predictions based on observed patterns, collected data, or data provided from other sources. (ELA 1.1.1; Math SP-IV.2.3) GLO: A1, C2

3-0-3a. Brainstorm, with the class, one or more methods of finding the answer to a given question and reach consensus on which method to implement. GLO: C2, C7

3-0-3b. Identify, with the class, variables that have an impact on an investigation. GLO: A1, A2, C2, C7

3-0-3c. Create, with the class, a plan to answer a given question. (ELA 3.1.4) GLO: C2, C7

3-0-4a. Carry out a plan, and describe the steps followed. (Math SP-V.2.3) GLO: C2

3-0-5a. Make observations that are relevant to a specific question. GLO: A1, A2, C2

3-0-6c. Place materials and objects in a sequence or in groups using two or more attributes, and describe the system used. (Math PR-I.1.3) GLO: C2, C3, C5

3-0-7a. Draw a simple conclusion based on their observations. GLO: A1, A2, C2

(continued)



Testing the Strength of Bridge Materials

(continued)

TEACHER NOTES

SUGGESTIONS FOR ASSESSMENT

Have students use Blackline Master 2: Scientific Inquiry Recording Sheet: Grades 3 and 4.

Students must begin to recognize that factors or **variables** must be kept the same in order to be able to draw reasonable conclusions. Students should be encouraged to focus on one aspect or variable at a time, and try to control all the other variables. This way, any differences observed can be more accurately attributed to the variable being studied.

Observation Checklist: Investigating Materials

The student

- makes predictions based on data gathered from other sources
- brainstorms to develop a method to answer the question
- identifies variables
- contributes to the development of a plan
- carries out the plan
- describes the steps followed
- makes relevant observations
- records observations
- orders the materials according to strength
- draws a conclusion based on observations
- works cooperatively

PRESCRIBED LEARNING OUTCOMES	SUGGESTIONS FOR INSTRUCTION
<p><i>Students will...</i></p>	
<p>3-0-7b. Explain why conclusions related to classroom experiments should be based on multiple trials or classroom data rather than on an individual result. GLO: A1, A2, C2</p> <p>3-0-8a. Recognize that valid experiments normally have reproducible results, which may vary slightly. GLO: A1, A2, C2</p>	<p>➤ Investigating Ways to Increase Strength</p> <p>Brainstorm with the class possible ways to strengthen paper. Have students explore ways to fold and combine paper to make it stronger. (Students may fold paper into an accordion, make rolls and glue them together, combine layers of flat sheets, or make sandwich layers with folded and rolled paper. Use a plasticine weight, graduated weights, bricks, wooden blocks, or books as weights to test the strength of each paper configuration. Students should describe each paper configuration they used and record the weight it supported by using a chart. Ask students the following reflection questions to guide classroom discussions:</p> <ul style="list-style-type: none"> • What did you do to get your paper to support a greater load? • How do we use this information in our everyday lives? (e.g., corrugated cardboard) <p>➤ Science Learning Logs</p> <p>Have students reflect on their learning and record their understandings in their science journals. (See <i>ELA, Strategies</i>, p. 110.)</p>
<p>3-2-04 Explore to determine an appropriate method for joining two materials for a specific use.</p> <p>GLO: C2, D3</p>	<p>➤ Investigation of Fasteners</p> <p>Have students work in small groups to determine the most appropriate method for joining materials. Challenge each group to construct four towers of a specific height using a given number of plastic straws. Each tower should use a different type of material or object for fastening. The amount of material or number of objects provided should be the same for each group. Example: 30 cm of masking tape or 12 paper clips per group.</p> <p>Samples of fasteners for straws:</p> <p>paper clips, tape, pipe cleaners, twist ties, glue, plasticine/modelling clay, marshmallows</p> <p>for wood (popsicle sticks):</p> <p>glue, nails, tape</p> <p>for paper:</p> <p>glue, tape, paper clips, staples</p>
<p>3-0-4f. Assume roles and share responsibilities as group members. (ELA 5.2.1) GLO: C7</p> <p>3-0-4h. Follow given safety procedures and rules, and explain why they are needed. GLO: C1</p> <p>3-0-5c. Estimate and measure mass/weight, length, volume, and temperature using standard units. (Math SS-IV.1.3, SS-I.1.3, SS-III.1.3, SS-VIII.4.3) GLO: C2, C3, C5</p> <p>3-0-6a. Display data using more than one way to represent the same data. (Math SP-III.2.3) GLO: C2, C6</p> <p>3-0-6b. Discuss data and generate new questions from displayed data. (Math SP-IV.1.2) GLO: A1, A2, C2, C5</p>	

(continued)

TEACHER NOTES

SUGGESTIONS FOR ASSESSMENT

Science Journal Entry: Increasing Strength

Provide students with the following scenario:

Your group has been chosen to represent your school at a Science Olympics Competition. Your group’s first task is to construct a paper tower that will support a 500 g weight. The other group members are not sure how to make the paper strong enough to support the required weight. What would you suggest to them? Explain your thinking.

Look for ideas such as the following:

- folding the paper so that it has pleats (accordion-like)
- layering the paper
- rolling the paper

This investigation builds on student understanding of methods for joining materials begun in Grade 1, Cluster 3: Characteristics of Objects and Materials (1-3-09).

Self-Assessment: Investigation of Fasteners

Answer Yes or No.

1. I knew my job in the group. _____
2. I shared responsibilities with the group. _____
3. I worked cooperatively. _____
4. I used the tools and materials appropriately and safely. _____
5. I measured accurately. _____
6. I recorded my observations and measurements carefully. _____

Complete the following phrases:

In this investigation I learned _____

 I still would like to know more about _____

PRESCRIBED LEARNING OUTCOMES
<i>Students will...</i>

SUGGESTIONS FOR INSTRUCTION

Have students compare the capability of each tower to support a given mass/weight. Use standard weights or equal-sized plasticine balls to test the strength of each tower. Students should record their results on a chart such as the one below.

Strength of Straw Towers with Fasteners	
<u>Fastener</u>	<u>Mass/Weight It Supported</u>
glue	_____
masking tape	_____
plasticine	_____
paper clips	_____

Provide time for students to reflect on and discuss their findings using the following questions to guide discussion:

- Which tower supported the most mass/weight?
- Which tower was the most difficult to build?
- Which tower was the most stable?
- Which tower looked the best?

<p>3-2-05 Recognize that balance affects the stability of a structure.</p> <p><i>Examples: a domino tower that leans to one side is more likely to tip over than one that stands straight...</i></p> <p>GLO: D4</p>
<p>3-0-4b. Construct an object or device to solve a problem or meet a need. GLO: C3</p> <p>3-0-8b. Recognize that scientists develop explanations from observations and what they already know about the world, and that good explanations are based on evidence. GLO: A1, A2, C2</p>

➤ **Investigating Balance**

Have students build a tower with dominoes. Ask students the following questions:

- How high can you make the tower?
- What did you notice just before the tower collapsed?

Have students build the tallest tower they can out of cards. Ask them what they notice just before the tower collapses.

(continued)

(continued)

TEACHER NOTES

SUGGESTIONS FOR ASSESSMENT

Science Journal Entry: Investigating Balance

Have students answer the following question in their journals:
Why is it important to build a balanced structure? Use both words and labelled diagrams in your answer.

The student

- draws a balanced tower (doesn't lean to one side)
- explains that the tower must be balanced or it will tip over

PRESCRIBED LEARNING OUTCOMES
<i>Students will...</i>
<p>3-2-06 Explore to determine ways to improve the strength and stability of a frame structure. <i>Examples: use of triangulation or a cross member...</i> GLO: C2, D4, E2</p> <p>3-2-07 Identify shapes that are part of natural and human-built structures from various cultures and describe how these shapes help to provide strength and stability. <i>Examples: cylinders, triangles, hexagons in outdoor play structure, hexagons in a honeycomb...</i> GLO: A4, D4, E2</p>
<p>3-0-1a. Ask questions that lead to investigations of living things, objects, and events in the local environment. (ELA 1.2.4) GLO: A1, C2, C5</p> <p>3-0-5a. Make observations that are relevant to a specific question. GLO: A1, A2, C2</p> <p>3-0-5b. Use tools to observe, measure, and construct. Include: ruler, metre stick, pan balance, magnifying glass, bathroom scale, thermometer, magnet. (Math SS-I.1.3, SS-III.1.3, SS-IV.1.3, SS-VII.4.3) GLO: C2, C3, C5</p> <p>3-0-5c. Estimate and measure mass/weight, length, volume, and temperature using standard units. (Math SS-IV.1.3, SS-I.1.3, SS-III.1.3, SS-VIII.4.3) GLO: C2, C3, C5</p> <p>3-0-5d. Estimate and measure the passage of time using standard units. Include: seconds, minutes, hours. (Math SS-VI.1.3) GLO: C2, C3, C5</p> <p>3-0-5e. Record observations in a variety of ways. <i>Examples: point-form notes, sentences, simple diagrams, charts...</i> (ELA 3.2.1, 3.3.2, 4.1.3; Math SP-II.2.1, SP-V.2.3) GLO: C2, C6</p> <p>3-0-9c. Take the time to repeat a measurement or observation for greater precision or detail. GLO: C5</p>

SUGGESTIONS FOR INSTRUCTION

- **Identifying Frame Structures**
 Have students sort pictures of a variety of structures as “frame” and “other structures.” Include pictures of bridges, towers, playground equipment, and commercial and residential buildings. Discuss to ensure students understand the concept of frame structures.

- **Investigating Strength of Frame Shapes**
Part 1 — Construction
 Ask students: What shape makes the strongest and most stable frame structure? Have students use straws joined with twist-ties to construct a variety of shapes, e.g., triangular prism, square prism, pentagonal prism, etc. Have students test their frame structures to see which structure supports the most weight and is the most stable. Tests should involve loads of increasing mass/weight or time to see how long the structure remains standing.
 Note: **Part 2 — Improving Design** will be completed following **Observing the Environment**.

- **Observing the Environment**
 - 1. Natural Structures**
 Have students look at examples of structure/shapes occurring in nature. Examples: bees’/wasps’ nests, sea shells, ant/termite hills, birds’ nests, etc.
 - 2. Structures from Many Cultures**
 Have students view and discuss illustrations of a variety of structures from different cultures, e.g., arches, columns, piers, teepees, earthlodges, quinzhees, etc.
 - 3. Local Structures**
 Take a walk through the schoolyard and around the immediate neighbourhood to observe natural and human-built structures. Encourage students to make scientific notes about the shapes they see and what has been done to ensure the stability of each structure.
 Pose the following reflection questions to help students determine what they know about structures:
 - What types of shapes are most common in our environment?
 - Who or what makes structures in our environment?
 - What types of shapes are common in other parts of the world?
 - How are structures made strong and stable?

(continued)

TEACHER NOTES

SUGGESTIONS FOR ASSESSMENT

A **structure** can refer to any type of object, be it natural or human-made. It must support its own weight and whatever load is placed upon it. Structures can be grouped into the following three broad categories:

Solid Structures are made from a solid piece of material, having little or no space inside, e.g., solid rubber ball, hockey puck, stone monument, etc.

Frame Structures are made from parts joined together in a framework, e.g., construction crane, skeleton, suspension bridges, etc.

Shell Structures are held together by an outer “skin,” e.g., drink can, egg carton, etc.

Many objects are a combination of a frame and shell structure, such as the human body or a tent. In this cluster, the focus is on frame structures.

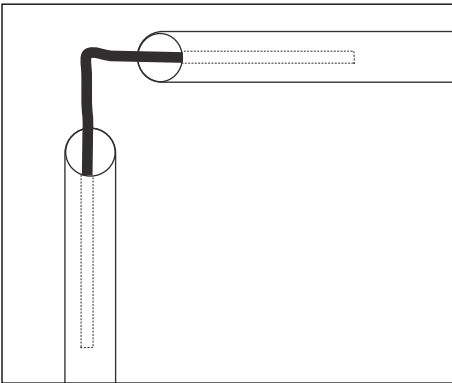

Joining Straws with Twist-Ties

(continued)

PRESCRIBED LEARNING OUTCOMES

SUGGESTIONS FOR INSTRUCTION

Students will...

➤ **Investigating Strength of Frame Shapes**
Part 2 — Improving Design
 Have students use understandings about structures from **Exploring the Environment** to modify one of the frame structures they constructed to make it stronger or more stable. Have students test their structures again.
 Pose the following questions to enable students to reflect on what they have learned:

- Which shape was the strongest?
- How did you get your shape to become stronger and more stable?
- What natural or human-made structure gave you ideas for improving your frame structure?

3-2-08 Identify characteristics of materials that need to be considered when choosing materials for building structures.
Examples: strength, flexibility, durability, surface texture...
 GLO: D3

➤ **Activate Prior Knowledge**
 Set the purpose for building structures using the following questions to stimulate thinking and generate discussion:

- What materials are best suited for specific structures when building the frame?
- What materials are best suited for specific structures when constructing the surface?
- What conditions determine the materials used?

3-0-4e. Respond respectfully to the ideas and actions of others, and recognize their ideas and contributions. (ELA 1.1.2, 5.2.2) GLO: C5, C7

➤ **If, Then . . .**
 Have students work in small groups to reflect on and discuss responses to “If... then...” scenarios such as the following:

- If we needed to build a boat launch for a steep riverbank, then what materials would we use for the frame? For the surface? Why?
- If we needed to build a bridge over a river with many rapids, then what materials would we use for a frame? For the surface? Why?
- If we needed a fire tower built in the forest, then what materials would we use for the frame? For the surface? Why?

Have students make a list of the materials they would use to construct the particular structure for each scenario and justify their choices (terms such as strong, smooth/rough, durable should emerge). (Note: you may wish to provide students with illustrations of some structures to aid them with this task.)
 Have students summarize the characteristics they considered when deciding what material to use.

TEACHER NOTES

SUGGESTIONS FOR ASSESSMENT

Encourage students to use cross-bracing or triangulation to increase the stability of structures. The **triangle** is a very strong shape and it is often used to stabilize structures. Structures made from many triangles put together are very strong. **Cross-braces** are additional beams or pieces that can be added on to a structure to stabilize or strengthen it.

Discuss with students what they should do if they see an unsafe structure.

Paper and Pencil Task: Frame Shapes and Structures

Have students answer True or False.

1. The triangle is a very strong shape.
2. There are many examples of structures/shapes in nature.
3. Many cultures use the same shapes in their structures.
4. Balance does not affect the stability of a structure.
5. Many of the shapes found in nature can be found in structures around the school.

Provide students with a picture of a playground structure or another human-made structure.

Have students observe the picture and then answer the following questions:

1. What shapes do you see in the picture?
2. How do these shapes help to provide strength and stability to the structure?

PRESCRIBED LEARNING OUTCOMES
<i>Students will...</i>
<p>3-2-09 Use the design process to build a structure that meets given criteria related to strength, stability, and function. GLO: A3, C3</p>
<p>3-0-1c. Identify practical problems to solve in the local environment. GLO: C3</p> <p>3-0-3d. Brainstorm, in small groups, possible solutions to a practical problem, and reach consensus on which solution to implement. GLO: C3, C7</p> <p>3-0-3e. Create, in small groups, a written plan to solve a problem or meet a need. Include: identify steps to follow, prepare a simple diagram. (ELA 1.2.3) GLO: C3, C7</p> <p>3-0-4b. Construct an object or device to solve a problem or meet a need. GLO: C3</p> <p>3-0-4c. Test an object or device with respect to pre-determined criteria. GLO: C3, C5</p> <p>3-0-4d. Identify and make improvements to an object or device, and explain the rationale for the changes. GLO: C3</p> <p>3-0-4f. Assume roles and share responsibilities as group members. (ELA 5.2.1) GLO: C7</p> <p>3-0-7c. Identify new problems that arise. GLO: C3</p> <p>3-0-8c. Recognize that designing a solution to a simple problem may have considerations, such as cost, materials, time, and space. GLO: B2, C3</p>
<p>3-2-10 Describe the effects of various forces on different structures. <i>Examples: bookshelf sagging under the mass/weight of books, tent blowing over in a storm...</i> GLO: D4, E2</p> <p>3-2-11 Evaluate simple structures to determine if they are safe and appropriate to the user. <i>Examples: classroom furniture...</i> GLO: C1, C3, C4, D4</p>
<p>3-0-2a. Access information using a variety of sources. <i>Examples: children's magazines, local farmers, CD-ROMs, Internet...</i> (ELA 1.1.2, 3.2.2; Math SP-1.1.2.3; TFS 2.1.1) GLO: C6</p> <p>3-0-2b. Review information to determine its usefulness to research needs. (ELA 3.2.3, 3.3.3) GLO: C6, C8 (continued)</p>

SUGGESTIONS FOR INSTRUCTION

➤ **Design Project**

Have students work in small groups to solve a given problem using the skills and knowledge already learned in this cluster. Establish specific criteria regarding size, strength, and amount of materials needed. Problems can emerge from literature or other subject areas such as social studies or physical education.

Sample Project: The Incredible Marble Game

Construct a table game for younger children. The game must be a linked collection of free-standing structures along which a marble will roll. Provide students with a selection of materials to use and assign each a dollar value. Give students a budget to which they must adhere during the construction phase. Criteria for evaluating the finished design include the following elements:

- fits on a student desk
- contains at least two identifiable structures modelled on natural or human-made structures observed in this cluster
- uses at least two different fastening or joining methods
- includes a path for the marble
- utilizes materials provided
- is within budget
- is safe for young children

➤ **Houses Fall Down**

Read or retell the story of *The Three Little Pigs*. Ask students the following questions:

- What caused the stick house to blow down?
- Do you think it was a strong structure? Why or why not?
- Why didn't the brick house fall down?
- Can any forces knock down brick houses?

➤ **Withstanding Forces**

Have students read or view informational resources about the way structures are designed to withstand forces. Have students identify some of the forces that may affect structures, such as wind, water, earthquakes, and tornadoes. Discuss and record interesting facts they discover.

(continued)

TEACHER NOTES

SUGGESTIONS FOR ASSESSMENT

Have students use Blackline Master 4 Design Process Recording Sheet: Grades 3 and 4.

In Grade 3, students will begin planning steps to follow and identifying evaluation criteria in small groups, rather than with the whole class. It is important for the teacher to ensure strong group-work skills are in place and to provide support to groups as needed.

Design Process Checklist

The student

- understands the problem
- actively participates in small-group brainstorming
- includes written list of steps to follow
- includes simple diagram
- contributes to the development of design criteria
- constructs the structure
- tests the structure based on given criteria
- identifies improvements to be made
- makes improvements
- works cooperatively
- shares group responsibilities

Student/Group Assessment of the Process and Structure

As a group, we

- planned our structure before building
- estimated the cost
- reflected on our plan before the construction
- cooperated and shared ideas as we were building
- tested our structure and made changes
- reflected on what we did well and what we would change the next time

The concept of forces acting on different structures is a link to Grade 3, Cluster 3: Forces that Attract or Repel. Recognition of gravity as a force is addressed in that cluster.

Paper and Pencil Task: Picturing Force

Student directions: Draw a picture to show the effect of a force on a structure and explain what is happening through words and diagrams.

The student

- clearly shows the effect of the force
- clearly explains what is happening using the term “force”

PRESCRIBED LEARNING OUTCOMES	SUGGESTIONS FOR INSTRUCTION
<p><i>Students will...</i></p>	
<p>3-0-7d. Examine how new experiences, ideas, and information connect to prior knowledge and experiences, and record these connections. (ELA 1.2.1, 2.1.2, 3.3.3) GLO: A2, C6</p> <p>3-0-7e. Communicate results and conclusions in a variety of ways. <i>Examples: point-form lists, sentences, simple diagrams, charts, demonstrations...</i> (ELA 2.3.5, 3.3.2, 4.1.3; Math SP-III.2.3; TFS 2.1.4) GLO: C6</p>	<p>➤ School Structures: Labelled Diagrams</p> <p>Have students draw and label diagrams of structures in their school environment. Students should include information to explain structural designs and materials that make these objects safe. Include items such as desks, bookshelves, computer tables, AV carts, gym equipment, outdoor play structures, etc. Ask the following questions to help students clarify what they learned:</p> <ul style="list-style-type: none"> • What helped the structures to be safe? • What could cause them to become unsafe?
<p>3-2-12 Investigate to identify hobbies and jobs related to construction, engineering, and architecture.</p> <p>GLO: B4</p>	<p>➤ Identifying Jobs and Hobbies</p> <p>As a class, brainstorm and list jobs and hobbies that involve knowledge of structural design and materials.</p>
<p>3-0-4g. Verbalize questions, ideas, and intentions during classroom-learning experiences. GLO: C6</p>	<p>➤ Guest Speakers</p> <p>Invite a guest speaker such as an engineer, architect, and/or construction worker to discuss his/her career, job responsibilities, and training with regard to forces and structures.</p>
<p>3-2-13 Identify various materials used in the construction of buildings in their community and in communities around the world.</p> <p>GLO: A4, B1, D3, E1</p>	<p>➤ Inquiry Chart: Building Materials Here and Around the World</p> <p>Have students work individually or in pairs to answer the following inquiry questions:</p> <ul style="list-style-type: none"> • What materials do we use most in Canada for building homes, bridges, and towers? • What materials are used most in _____ (name of country) for building homes, bridges, and towers? The country could include a place students are currently studying in social studies.
<p>3-0-1a. Ask questions that lead to investigations of living things, objects, and events in the local environment. (ELA 1.2.4) GLO: A1, C2, C5</p> <p>3-0-2a. Access information using a variety of sources. <i>Examples: children's magazines, local farmers, CD-ROMs, Internet...</i> (ELA 1.1.2, 3.2.2; Math SP-I.1.2.3; TFS 2.1.1) GLO: C6</p> <p>3-0-2b. Review information to determine its usefulness to research needs. (ELA 3.2.3, 3.3.3) GLO: C6, C8</p> <p>3-0-3a. Brainstorm, with the class, one or more methods of finding the answer to a given question and reach consensus on which method to implement. GLO: C2, C7</p> <p>3-0-7e. Communicate results and conclusions in a variety of ways. <i>Examples: point-form lists, sentences, simple diagrams, charts, demonstrations...</i> (ELA 2.3.5, 3.3.2, 4.1.3; Math SP-III.2.3; TFS 2.1.4) GLO: C6</p>	<p>Have students describe the style and identify some of the reasons for the design of: buildings in earthquake areas such as California or Japan; thatched-roof dwellings in Africa; etc. Have students carry out research through interviews, magazine pictures, videotapes, CD-ROMs, the Internet, etc. Students could present their findings using an Inquiry Chart (Hoffman, 1992 and 1997 and <i>ELA, Strategies</i>, pp. 83 - 88).</p>

TEACHER NOTES

SUGGESTIONS FOR ASSESSMENT

Discuss with students what they should do if they see an unsafe structure.

Learning Log: Building Materials Here and Around the World

Have students summarize what they learned about materials and style used in buildings around the world by completing the following:

1. In Canada we use these materials: _____.
2. Other countries use materials such as: _____.
3. People in different places use different materials for building homes because: (available materials, climatic conditions, other)
_____.

NOTES

Grade 3

Cluster 3: Forces that Attract or Repel

Overview

In Grade 3, students build on their initial awareness of forces as pushes or pulls (see *Grade 2, Cluster 3: Position and Motion*). In this cluster, the focus is on forces that act without direct contact: gravity, magnetism, and static electricity. Students describe evidence that shows that objects and living things on or near Earth are affected by a force called gravity, enhancing their understanding of the nature of science. Through their investigations, they determine that magnets have two poles and are surrounded by a magnetic field. They describe interactions of like and unlike poles, and compare Earth to a giant magnet. In addition, they identify ways of producing electrostatic charges using everyday materials. Students show how the strength of magnetic and electrostatic forces varies under different conditions. New understandings of gravity, magnetism, and static electricity are further refined as students identify and construct devices that use these forces.

PRESCRIBED LEARNING OUTCOMES

SUGGESTIONS FOR INSTRUCTION

Students will...

3-3-01 Use appropriate vocabulary related to their investigations of forces.
 Include: force, attract, repel, gravity, magnet, magnetize, magnetism, north pole, south pole, magnetic field, compass, electrostatic charge, static electricity, electrostatic force.
 GLO: C6, D4

➤ Introduce, explain, use, and reinforce vocabulary throughout this cluster.

3-3-02 Recognize that force is a push or pull and that attraction and repulsion are types of pushes and pulls.
 GLO: D4

➤ **Observing Forces**

Have students work in cooperative groups to explore how various objects move. Use objects such as toy cars, ball point pens, balls, wagons, toboggans, vacuum cleaners, etc. Have students classify objects that move according to the grid below.

Moves Using "Pushes"	Moves Using "Pulls"

3-0-4e. Respond respectfully to the ideas and actions of others, and recognize their ideas and contributions. (ELA 1.1.2, 5.2.2) GLO: C5, C7
3-0-4f. Assume roles and share responsibilities as group members. (ELA 5.2.1) GLO: C7

Ask the following question: "What are pushes and pulls?" If the term "force" does not come up in the discussion, introduce it at this time.

3-3-03 Describe evidence showing that objects and living things on or near Earth are pulled toward it by a force called gravity.
 GLO: A2, D4

➤ **Gravity in Space**

Have students view video clips showing astronauts in space and in spaceships. Use these images to initiate a discussion on gravity.

➤ **Finding Evidence of Gravity**

Have students observe their environment to find evidence of gravity. Example:

Place	Evidence
classroom	pencil falls off desk
playground	fly ball falls to ground
park	leaves fall off tree

3-0-2a. Access information using a variety of sources. *Examples: children's magazines, local farmers, CD-ROMs, Internet...* (ELA 1.1.2, 3.2.2; Math SP-I.1.2.3; TFS 2.1.1) GLO: C6
3-0-4f. Assume roles and share responsibilities as group members. (ELA 5.2.1) GLO: C7
3-0-5a. Make observations that are relevant to a specific question. GLO: A1, A2, C2

Ask students the following questions:

- Why do things fall to the ground?
- Why don't we fly off/fall off the Earth?

Ensure that a link is made to gravity as a pull and therefore a type of force, during discussions of gravity.

TEACHER NOTES

SUGGESTIONS FOR ASSESSMENT

Caution: Ensure that students are aware that a magnet should not be held near the following technological devices: television, VCR, microwave oven, computer, radio, loudspeakers, credit cards, wind-up watches, computer discs, audiocassettes, tape recorders, telephones, answering machines, and videotapes. Magnets disrupt the electronic components. This results in permanent damage.

The space around a large mass, such as the Earth, is called a **gravitational field**. It's the area where the force of gravity acts or can be felt.

Science Journal Entry: Gravity in Space

Have students answer the following question in their science journals: Gravity is invisible. What evidence do we have that gravity is acting on objects on the Earth? Give at least six examples.

Look for the following examples:

- objects falling
- water running downhill
- a ball thrown into the air comes back down again

PRESCRIBED LEARNING OUTCOMES
<i>Students will...</i>
<p>3-3-04 Predict and test to identify materials that are attracted by magnets and those that can be magnetized. GLO: C2,, C5 D3</p> <p>3-3-05 Investigate to determine how to magnetize a given object. Include: contact with another magnet, proximity to a magnet. GLO: C2, D4</p>
<p>3-0-1b. Make predictions based on observed patterns, collected data, or data provided from other sources. (ELA 1.1.1; Math SP-IV.2.3) GLO: A1, C2</p> <p>3-0-3d. Brainstorm, in small groups, possible solutions to a practical problem, and reach consensus on which solution to implement. GLO: C3, C7</p> <p>3-0-4a. Carry out a plan, and describe the steps followed. (Math SP-V.2.3) GLO: C2</p> <p>3-0-4g. Verbalize questions, ideas, and intentions during classroom-learning experiences. GLO: C6</p> <p>3-0-7e. Communicate results and conclusions in a variety of ways. <i>Examples: point-form lists, sentences, simple diagrams, charts, demonstrations...</i> (ELA 2.3.5, 3.3.2, 4.1.3; Math SP-III.2.3; TFS 2.1.4) GLO: C6</p>

SUGGESTIONS FOR INSTRUCTION

➤ **Magnetic or Not?**

Provide students with a variety of objects. Have students predict which objects will be attracted to the magnet. Include metals such as copper, brass, and aluminum which are not magnetic. Have students test to determine the accuracy of their predictions.

<u>Item</u>	<u>Prediction</u>	<u>Attracted</u>
paper clip	attract	yes
straw	will not attract	no

Provide students with an opportunity to review and reflect on the results. Help guide students' reflections by asking the following question:

How are the materials attracted by magnets alike?

➤ **Investigation — Creating Temporary Magnets**

Provide students with bar magnets, paper clips, and iron nails. Tell students that temporary magnets can be made by stroking the metallic object with a magnet. Have students test to determine whether they can magnetize a paper clip and an iron nail. Following the investigation, ask students the following questions to reflect on the process:

- Were you able to magnetize the paper clip and the nail?
- What procedure did you try?
- What procedure worked best?
- What did you notice about the strength of the magnetic attraction with the paper clip and the nail?

Have students try to magnetize other materials and report their findings to the class.

➤ **Magnetic Neighbours**

Have students use a permanent magnet and a non-magnetic metallic object, such as a paper clip to determine whether an object can become magnetized from being near a magnet.

TEACHER NOTES

There are three different kinds of magnets: natural, temporary, and permanent.

Natural magnets are rocks with a lot of iron in them and are magnetic when found in the ground (lodestone).

Temporary magnets can be made from steel; however, they are weak and last only a short time.

Permanent magnets are made from hard iron (iron and other materials).

Magnets need to be stored properly in order to ensure that they stay strongly magnetized. They should be stored with opposite poles together.

If magnets do become de-magnetized, they can be re-magnetized. High school science labs often have the device with which to effect this. If not, it can be purchased from a science supply store.

attract - to pull toward or hold in place

repel - to push away or force apart

magnet - a material that can attract a piece of iron

ceramic magnet - magnets made from a powdered iron oxide called ferrite, are strong and versatile

When a magnetic metal is attracted to a permanent magnet, it becomes a magnet, too. It can attract other objects but only while it is touching a permanent magnet. This is called **induced magnetism**.

SUGGESTIONS FOR ASSESSMENT

Observation Checklist: Magnetic or Not?

The student

- uses safe and appropriate procedures with the magnets
- records observations accurately
- predicts which objects would be attracted to a magnet
- tests to confirm predictions
- participates in the development of a plan for magnetizing an object
- follows the plan
- asks relevant questions
- explains ideas to others
- represents findings using a variety of methods
- demonstrates proper care of magnets

PRESCRIBED LEARNING OUTCOMES
<i>Students will...</i>
<p>3-3-06 Investigate to determine the location of poles on a magnet, and the shape of the magnetic field around a magnet. GLO: A1, C2, D4</p> <p>3-3-07 Demonstrate that opposite poles attract and like poles repel. GLO: C2, D4</p>
<p>3-0-4h. Follow given safety procedures and rules, and explain why they are needed. GLO: C1</p> <p>3-0-7e. Communicate results and conclusions in a variety of ways. <i>Examples: point-form lists, sentences, simple diagrams, charts, demonstrations...</i> (ELA 2.3.5, 3.3.2, 4.1.3; Math SP-III.2.3; TFS 2.1.4) GLO: C6</p> <p>3-0-9a. Listen to and consider differing opinions. (ELA 5.2.3) GLO: C5, C7</p>

SUGGESTIONS FOR INSTRUCTION

➤ **Exploring Magnetic Poles**

Part 1) Provide small groups of students with two bar magnets that have their poles labelled. (This can be done with masking tape.)

Have students explore to determine what happens when like poles are placed together and when unlike poles are placed together. Have each group present its findings. If the terms “repel” and “attract” do not come up in the discussion, they should be introduced at this time. Students should recognize that because magnetism either pushes or pulls, it is a force.

Part 2) Provide each group with a labelled bar magnet and magnets that do not have labelled poles. Have students determine the location of the north and south poles on the unlabelled magnets and explain the procedure used.

➤ **Investigating Magnetic Fields**

Provide small groups of students with cardboard, iron filings in a shaker, and different types and shapes of magnets (bar, horseshoe, fridge). Have students place the magnet under the cardboard and then gently sprinkle the iron filings on top. Have students draw what they observe. Ask students the following questions:

- What did the magnets have in common?
- What do you call the pattern made by the iron filings? (magnetic field)

Have students explore to answer the following questions:

- How does the magnetic field change when you put north and south poles together?
- North and north poles together?
- South and south poles together?

TEACHER NOTES

SUGGESTIONS FOR ASSESSMENT

The space around a magnet is called the **magnetic field**. It's the area where the force of a magnet acts or can be felt.

Magnetic Fields

Where the lines are closest, th

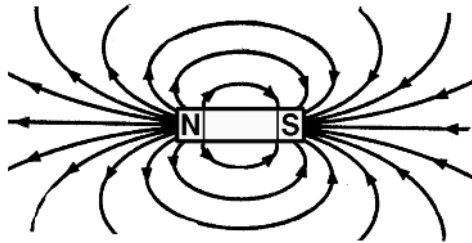

Where the lines are closest, the magnetic field is strongest.

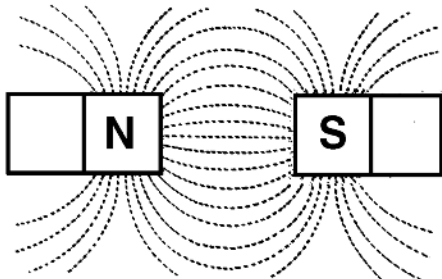

Two like poles (north and north, or south and south) push against or

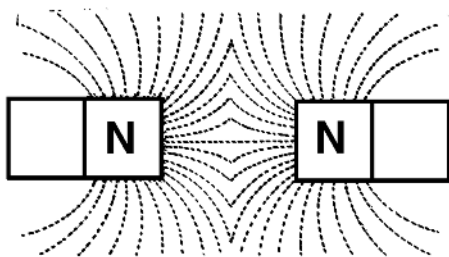

repel each other strongly.

Caution: Ensure magnets remain in the classroom and that students are

Interview: Magnets

Before the interview, gather a labelled bar magnet and an unlabelled bar magnet. Ask students the following questions:

1. Explain what will happen when the poles of two bar magnets are put together in the following ways:
 North pole to south pole? (They will be attracted to each other.)
 North pole to north pole? (They will repel each other.)
 South pole to south pole? (They will repel each other.)
2. Draw the magnetic field for this bar magnet. (See Teacher Notes.)



3. Explain how you would find the poles on a magnet that is not labelled. (Use the labelled bar magnet to find the poles on the unlabelled magnet.)
4. How should you care for magnets?
 - don't drop them
 - store them with unlike poles together
 - keep them away from electronic equipment
 - other

PRESCRIBED LEARNING OUTCOMES

SUGGESTIONS FOR INSTRUCTION

Students will...

3-3-08 Explain why Earth can be compared to a giant magnet.
 Include: Earth has a magnetic field with poles adjacent to the geographic poles.
 GLO: D4, E1, E2

3-3-09 Demonstrate and explain how a compass operates by magnetism.
 Include: Earth’s magnetic pole attracts the magnetic needle of a compass.
 GLO: B1, D4

3-0-4a. Carry out a plan, and describe the steps followed. (Math SP-V.2.3) GLO: C2

3-0-5a. Make observations that are relevant to a specific question. GLO: A1, A2, C2

3-0-5b. Use tools to observe, measure, and construct. Include: ruler, metre stick, pan balance, magnifying glass, bathroom scale, thermometer, magnet. (Math SS-I.1.3, SS-III.1.3, SS-IV.1.3, SS-VII.4.3) GLO: C2, C3, C5

3-0-9c. Take the time to repeat a measurement or observation for greater precision or detail. GLO: C5

➤ **Earth Magnetic Simulation**

Stick a bar magnet through the centre of an orange but make sure the ends are visible to the students. Demonstrate with a compass that the needle will point to the magnet’s north when placed near the orange. If you go outside with your compass, the needle will point to the Earth’s magnetic north.

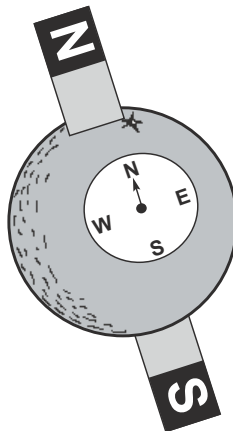

➤ **Making Floating Compasses**

Have the students work in small groups to make floating compasses. Have students gather needed materials including: objects that float such as a leaf, piece of styrofoam, cork or piece of plastic; a magnet; a non-metallic dish of water; and a large sewing needle. Have students magnetize the needle with the magnet and test it to ensure it is magnetized. Students then place the floating device in the water and set the needle on it. The floating device should turn until the needle points north/south. Use a compass to test if the needle is pointing north. Turn the floating needle away from the north and observe what happens. Use the following questions to guide the discussion:

- What causes the needle to point to the north magnetic pole?
- Why couldn’t you use a steel bowl to hold the water?

(continued)

TEACHER NOTES

SUGGESTIONS FOR ASSESSMENT

The centre, or inner core of the Earth is made up of iron and nickel. This inner core flows and rotates faster than the outer core and it is believed that this movement creates the **Earth's magnetic field**.

As a magnet, the Earth has north and south magnetic poles. Scientists have found that the location of the poles is shifting over time. Every few hundred thousand years, the magnetic poles actually reverse themselves, but scientists don't know why.

The Earth also has another set of poles, the geographic North and South Poles. These poles are at the axis upon which the Earth turns. The **magnetic north pole** and the **geographic North Pole** are approximately 1600 kilometres apart. People navigating using a compass and geographic maps must make adjustments for the differences in location between the two north poles of the Earth.

Ensure that the discussion of the Earth as a magnet does not become confused with discussions about gravity.

Performance Task: Finding Poles With a Compass

Student directions: You have been asked to determine the poles on an unmarked magnet using only a magnetic compass. Develop a written plan. Demonstrate how your plan works, using the unmarked magnet and a compass.

Scoring Rubric

Scale	Plan	Follows Plan	Identifies Poles
4	complete and well organized	yes	yes
3	clear and complete	yes	yes
2	complete but unclear	yes, with assistance	perhaps
1	unclear, may contain misconceptions	no	perhaps

PRESCRIBED LEARNING OUTCOMES

SUGGESTIONS FOR INSTRUCTION

Students will...

➤ **Finding Poles With a Compass**

Have students use a magnetic compass and a bar magnet to observe the effects of moving the compass to different locations around the bar magnet. Students should record their observations in their science journals.

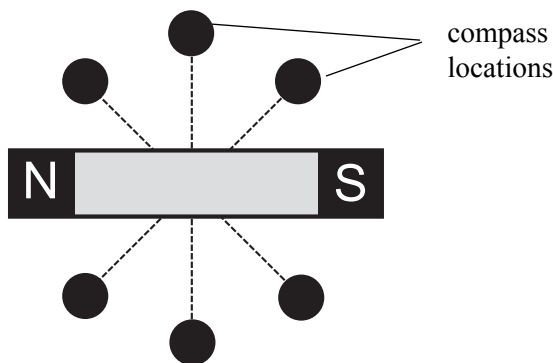

Ask students: “How can you use this information to locate the poles on an unmarked magnet?” Have students test to determine if their plan will work.

3-3-10 Describe potentially harmful effects of magnets on magnetized materials.
Examples: computers, videotapes, credit cards...
GLO: B1, C1, D4

➤ **Magnets Affect Electronic Equipment**

Part 1) Make a tape and play it for the students. Place a magnet close to the tape and play the tape again. Discuss the results using the following questions:

- What happened to the tape?
- Why did this happen?

Part 2) Show students a sensor pad warning label.



3-0-2a. Access information using a variety of sources. *Examples: children’s magazines, local farmers, CD-ROMs, Internet...* (ELA 1.1.2, 3.2.2; Math SP-I.1.2.3; TFS 2.1.1) GLO: C6
3-0-2b. Review information to determine its usefulness to research needs. (ELA 3.2.3, 3.3.3) GLO: C6, C8
3-0-4h. Follow given safety procedures and rules, and explain why they are needed. GLO: C1

Ask the students what other objects might be affected by magnets and record the information on a class chart. Have students add to the chart as study of the cluster ensues. For this learning outcome, any research that takes place should be undertaken by using books, CD-ROMs, the Internet, etc., and not by exploring with magnets.

TEACHER NOTES

SUGGESTIONS FOR ASSESSMENT

aware of the potential danger they pose to magnetized devices such as computers.

The **atoms** of all matter are made up of **electrons** (negative charges),

PRESCRIBED LEARNING OUTCOMES
<i>Students will...</i>
<p>3-3-11 Describe and demonstrate ways to use everyday materials to produce electrostatic charges.</p> <p><i>Examples: rubbing feet on carpet, brushing hair, rubbing a balloon on clothes...</i></p> <p>GLO: D4</p>
<p>3-0-3b. Identify, with the class, variables that have an impact on an investigation. GLO: A1, A2, C2, C7</p> <p>3-0-7a. Draw a simple conclusion based on their observations. GLO: A1, A2, C2</p> <p>3-0-7b. Explain why conclusions related to classroom experiments should be based on multiple trials or classroom data rather than on an individual result. GLO: A1, A2, C2</p> <p>3-0-8a. Recognize that valid experiments normally have reproducible results, which may vary slightly. GLO: A1, A2, C2</p> <p>3-0-8b. Recognize that scientists develop explanations from observations and what they already know about the world, and that good explanations are based on evidence. GLO: A1, A2, C2</p>

SUGGESTIONS FOR INSTRUCTION

➤ **Exploring Electrostatic Charges**

Provide each student with an inflated balloon. Have them rub the balloon against their hair and observe what happens. Ask the students why they think this is happening. If the concept of static electricity or electrostatic charges does not occur in the discussion, it should be introduced at this time. Have students work with a partner or in small groups to find other ways of producing electrostatic charges. Provide materials such as: wool, cotton, polyester, paper, plastic, silk, a carpet sample, and charged inflated balloons.

➤ **Stick to It**

Have students select the three materials that they feel work best to create electrostatic charges. Have students investigate to see if increasing the number of times the balloon is rubbed increases the time that it will stick to the wall. Have students use a chart to record results.

Electrostatic Charges

<u># of Rubs</u>	<u>Material Used</u>	<u>Time It Clung</u>
5 rubs	cotton	
10 rubs	cotton	

Math link: graph the results.

Have students share the results with other pairs of students. Provide time for students to think about their results. Discuss findings using the following questions:

- Does the balloon stick longer when rubbed with certain materials?
- Do more rubs with the same material increase the sticking time?
- Are the results from your group the same as results from other groups? Why or why not?

TEACHER NOTES

SUGGESTIONS FOR ASSESSMENT

protons (positive charges), and **neutrons** (no charge). Protons and neutrons are found in the nucleus. Electrons whirl around the nucleus. Some have the ability to move from one atom to another. There are an equal number of protons and electrons in each atom. As a result, atoms are ordinarily electrically **neutral**.

When a balloon is rubbed on a cloth, electrons are transferred from the cloth to the balloon. The balloon becomes negatively charged. If a balloon comes in contact with a neutral wall/hair, etc., it pushes away electrons from that section of the wall/hair. This results in a positive charge on that part of the wall. Because opposites attract, the balloon will stick to the wall or will make the hair stick to the balloon temporarily. After a while the negative electrons pass from the balloon to the wall and also into the air. Then the balloon/hair falls.

Caution: Do not allow students to put balloons on the computers. Remind them that computers should always be grounded.

Lightning is caused by static electricity. Sparks jump between two

Science Journal Entry: Electrostatic Charges

Student directions: Describe, using words and diagrams, how to produce a static charge.

Look for

- rubbing two materials together
- rubbing long enough to create a charge (more than just touching two materials together)

PRESCRIBED LEARNING OUTCOMES
<i>Students will...</i>
<p>3-3-12 Investigate to determine how electrostatically charged materials interact with each other and with uncharged materials.</p> <p>Include: charged materials attract or repel each other, charged materials attract uncharged materials.</p> <p>GLO: A2, C2, D4</p>
<p>3-0-1b. Make predictions based on observed patterns, collected data, or data provided from other sources. (ELA 1.1.1; Math SP-IV.2.3) GLO: A1, C2</p> <p>3-0-3c. Create, with the class, a plan to answer a given question. (ELA 3.1.4) GLO: C2, C7</p> <p>3-0-5e. Record observations in a variety of ways. <i>Examples: point-form notes, sentences, simple diagrams, charts...</i> (ELA 3.2.1, 3.3.2, 4.1.3; Math SP-II.2.1, SP-V.2.3) GLO: C2, C6</p> <p>3-0-7a. Draw a simple conclusion based on their observations. GLO: A1, A2, C2</p>

SUGGESTIONS FOR INSTRUCTION

- **Electrostatic Interactions**

Provide small groups of students with two inflated balloons and a length of thread or string for each. Have students tie a piece of thread on the end of each balloon and hold the balloons by their threads so that they are about 5 cm apart. Students observe what happens. Have students charge one balloon and then hold the balloons together. Have students charge both balloons and then hold them together. Use the following questions to guide the discussion:

 - What happens when uncharged materials are placed together? (Nothing.)
 - What happens to uncharged material when a statically charged material is placed near it? (It is attracted to the charged material.)
 - What happens when two statically charged materials come together? (They repel or attract one another.)

- **Statically Charged Materials**

Provide a piece of plastic wrap and paper towel for each student. Have students charge the plastic wrap by placing it on a flat surface and rubbing it with the paper towel. The students lift the plastic wrap by one corner and observe what happens and record their observations. Then have students straighten out the plastic wrap and rub it again to recharge. Have them pick it up in the midpoint of the opposite side and observe and record what happens.

- **Demonstration: Moving Water**

Charge a comb by rubbing it on a piece of wool. Hold the comb near slowly running tap water. Have students observe how the water reacts to the statically charged comb. (The water will surprisingly appear to be drawn to the comb.) Discuss the results.

TEACHER NOTES

SUGGESTIONS FOR ASSESSMENT

Paper and Pencil Task: Electrostatic Interactions

Using words and diagrams, have students answer the following questions:

- What happens when uncharged materials are placed together?
- What happens when uncharged materials come in contact with a statically charged material?
- What happens when two statically charged materials come together?

PRESCRIBED LEARNING OUTCOMES

SUGGESTIONS FOR INSTRUCTION

Students will...

3-3-13 Identify ways in which problems associated with static electricity can be avoided or eliminated.
Examples: staying indoors when there is a lightning storm, grounding yourself before using computers, avoiding shuffling your feet on carpets...
GLO: B1, C1, D4

3-0-4e. Respond respectfully to the ideas and actions of others, and recognize their ideas and contributions. (ELA 1.1.2, 5.2.2) GLO: C5, C7
3-0-4h. Follow given safety procedures and rules, and explain why they are needed. GLO: C1

➤ **Staying Safe**

Have students work in small groups to brainstorm and list what they might do to be safe during a lightning storm. Discuss with students the recommended safety precautions one should take if caught outside during a storm such as: crouch down, spread out, avoid trees, telephone poles, and fences, and do not touch metal objects, e.g., bicycle, fishing rod, etc.

➤ **Safety Posters**

Discuss with students home safety procedures to follow during a storm. Suggestions could include: avoid using the telephone unless there is an emergency, no standing near open doors or windows, and stay away from electrical appliances. Have students use these ideas to create safety posters.

➤ **Avoid the Static!**

Organize a discussion regarding the safety procedures to be used in order to avoid static electricity at school. Focus on the care of electronic equipment and the concern for personal safety. Students may suggest such things as grounding yourself before using the computer, avoiding shuffling feet on carpets, etc.

TEACHER NOTES

SUGGESTIONS FOR ASSESSMENT

areas of opposite and built-up electrical charges. This can occur from one part of a cloud to another or from a cloud to the ground. In the latter, there is a bolt from the cloud to the ground and a return bolt, upward from the ground. These two strokes appear as one lightning bolt and they take place in less than a second. Manitoba experiences intense summer thunderstorms and each year Manitobans are killed or seriously injured by lightning strikes.

PRESCRIBED LEARNING OUTCOMES

Students will...

3-3-14 Investigate to determine the change in magnetic and electrostatic forces at different distances.
GLO: C2, D4

3-0-3a. Brainstorm, with the class, one or more methods of finding the answer to a given question and reach consensus on which method to implement. GLO: C2, C7
3-0-3b. Identify, with the class, variables that have an impact on an investigation. GLO: A1, A2, C2, C7
3-0-3c. Create, with the class, a plan to answer a given question. (ELA 3.1.4) GLO: C2, C7
3-0-4a. Carry out a plan, and describe the steps followed. (Math SP-V.2.3) GLO: C2
3-0-5e. Record observations in a variety of ways. *Examples: point-form notes, sentences, simple diagrams, charts...* (ELA 3.2.1, 3.3.2, 4.1.3; Math SP-II.2.1, SP-V.2.3) GLO: C2, C6
3-0-6a. Display data using more than one way to represent the same data. (Math SP-III.2.3) GLO: C2, C6
3-0-6b. Discuss data and generate new questions from displayed data. (Math SP-IV.1.2) GLO: A1, A2, C2, C5

3-3-15 Predict and test to determine the effect of placing materials between a magnet and an attracted object and between charged objects.
Examples: different thicknesses of paper, glass, water, metal...
GLO: C2, C5, D4

3-0-1a. Ask questions that lead to investigations of living things, objects, and events in the local environment. (ELA 1.2.4) GLO: A1, C2, C5
3-0-1b. Make predictions based on observed patterns, collected data, or data provided from other sources. (ELA 1.1.1; Math SP-IV.2.3) GLO: A1, C2
3-0-4g. Verbalize questions, ideas, and intentions during classroom-learning experiences. GLO: C6
3-0-9b. Express enjoyment when sharing and discussing science-related experiences from daily life. (ELA 4.4.3) GLO: C5

SUGGESTIONS FOR INSTRUCTION

➤ **Forces Over Distances**

Part 1: Magnets

Have students work in pairs to determine if increasing the distance between a permanent magnet and an object has any effect on the strength of the magnetic force. Have students use a permanent magnet and a collection of paper clips. Students will gradually increase the distance between the magnet and the paper clips. They may record observations on a chart such as the following

<u>Distance</u>	<u>Number of Paper Clips Attracted</u>
1 cm	_____
2 cm	_____
3 cm	_____

Math Connection: Have students record their observations on a graph.

Part 2: Electrostatics

Have students develop and test a plan for examining the effects of increased distance on electrostatic forces. Have students report the results to the class. Example: Use a charged balloon to pick up small pieces of paper (small, circular scraps from a hole puncher).

➤ **Forces Through and Through**

Part 1: Magnets

Provide partners with a strong magnet, paper clips, and a variety of materials such as cardboard, paper of various thicknesses, fabric, glass, tinfoil, plastic, wooden rulers, etc. Have students predict the effect of placing different materials between the magnet and the paper clips. Students then test to determine if their prediction was accurate, and then record their findings on a chart such as the one below.

<u>Object</u>	<u>Prediction</u>	<u>Observation</u>
thin paper	-will still pick up paper clip	-picked up the paper clip
cardboard	_____	_____

Give each pair of students a clear glass of water with a paper clip in the water. Have students try to remove the paper clip using the magnet on the outside of the glass. Partners share their results with the class.

(continued)

TEACHER NOTES

SUGGESTIONS FOR ASSESSMENT

Have students use Blackline Master 2: Scientific Inquiry Recording Sheet: Grades 3 and 4.

Observation Checklist: Forces Over Distances

The student

- makes an organized list to record findings
- makes logical predictions based on previous observations
- uses safe and appropriate procedures
- works cooperatively and shared materials
- records predictions and observations accurately
- communicates results with others
- notices patterns forming in test results
- provides insight into the reaction of objects at different distances
- returns materials and tools to appropriate location

Self-Reflection: Forces Through and Through

1. I liked _____.
2. I had a problem with _____.
3. If I did this investigation again I would _____.
4. I learned _____.
5. I would like to learn more about _____.

PRESCRIBED LEARNING OUTCOMES

SUGGESTIONS FOR INSTRUCTION

Students will...

Part 2: Electrostatic Forces

Have students determine the effect of placing materials between charged objects using a procedure similar to the one above for magnets. Ask students the following questions:

- What effect does the addition of a material between the force and the attracted object have on the force itself?
- Why did some students get different results with the same materials?
- How did your results compare with your predictions?

3-3-16 Recognize that gravitational, magnetic, and electrostatic forces can move certain objects without touching them directly.

GLO: D4

3-3-17 Distinguish between motion that is caused without contact and that which is caused by contact.

GLO: D4

➤ **Reflection — Forces that Can Move without Touching**

Have students use their science journals to list or draw explorations they have undertaken showing how forces can push or pull objects causing them to move without directly touching them (all magnetic and electrostatic explorations). For contrast, remind students of some of the learning experiences from Grade 3, Cluster 2: Position and Motion, in which they caused objects to move using direct pushes and pulls.

3-0-7d. Examine how new experiences, ideas, and information connect to prior knowledge and experiences, and record these connections. (ELA 1.2.1, 2.1.2, 3.3.3) GLO: A2, C6

3-3-18 Identify devices that use gravitational, magnetic, or electrostatic forces.

Examples: balances, magnetic cupboard latches, dust mops...

GLO: B1, D4

➤ **Observing the Environment: Find the Force**

Have students explore the school environment to find uses of gravitational, magnetic, or electrostatic forces (e.g., fridge door, cupboard doors, balance scales, dust mops, etc.). Have students record their findings. Challenge students to add to their lists with examples from home.

3-0-7e. Communicate results and conclusions in a variety of ways. *Examples: point-form lists, sentences, simple diagrams, charts, demonstrations...* (ELA 2.3.5, 3.3.2, 4.1.3; Math SP-III.2.3; TFS 2.1.4) GLO: C6

TEACHER NOTES

SUGGESTIONS FOR ASSESSMENT

Self-Assessment: Creating Electrostatic Forces

(Answer Yes or No)

1. I followed written and oral directions during the investigation.
2. I worked in an organized way.
3. I kept trying even when I was not successful.
4. I talked about my discoveries with others.

During this investigation I learned _____
_____.

PRESCRIBED LEARNING OUTCOMES

SUGGESTIONS FOR INSTRUCTION

Students will...

3-3-19 Use the design process to construct a game, toy, or useful device that uses gravitational, magnetic, or electrostatic forces.
GLO: C3, C5

3-0-1c. Identify practical problems to solve in the local environment. GLO: C3

3-0-3d. Brainstorm, in small groups, possible solutions to a practical problem, and reach consensus on which solution to implement. GLO: C3, C7

3-0-3e. Create, in small groups, a written plan to solve a problem or meet a need. Include: identify steps to follow, prepare a simple diagram. (ELA 1.2.3) GLO: C3, C7

3-0-3f. Develop, in small groups, limited criteria to evaluate an object or device based on its function and aesthetics. GLO: C3, C7

3-0-4b. Construct an object or device to solve a problem or meet a need. GLO: C3

3-0-4c. Test an object or device with respect to pre-determined criteria. GLO: C3, C5

3-0-4d. Identify and make improvements to an object or device, and explain the rationale for the changes. GLO: C3

3-0-5b. Use tools to observe, measure, and construct. Include: ruler, metre stick, pan balance, magnifying glass, bathroom scale, thermometer, magnet. (Math SS-I.1.3, SS-III.1.3, SS-IV.1.3, SS-VII.4.3) GLO: C2, C3, C5

3-0-7c. Identify new problems that arise. GLO: C3

3-0-8c. Recognize that designing a solution to a simple problem may have considerations, such as cost, materials, time, and space. GLO: B2, C3

➤ **Design Project: Construct a Toy**

Sample design scenario: A local toy manufacturer is holding a design competition. In order to enter the contest you must design and construct a game or toy that uses gravitational, magnetic, or electrostatic forces. You must also prepare a presentation to show your product to the judges. Examples of toys or games could include the following:

- magnetic fishing game
- magnetic maze
- ring toss (uses gravity)
- gameboard for “Tic-Tac-Toe” that sticks to the fridge, a window, etc.
- paper jumping beans

To make paper jumping beans, use coloured construction or bond paper, and cut out small bean shapes. Place these in a card box with a clear plastic lid. Rub the lid with a cloth to make the beans jump and stick to the lid. Tap the lid to make the beans drop.

TEACHER NOTES

SUGGESTIONS FOR ASSESSMENT

Have students use Blackline Master 4:
Design Process Recording Sheet:
Grades 3 and 4.

Design Process Checklist: Construct a Toy

The student

- understands the problem
- actively participates in small-group brainstorming
- includes written list of steps to follow
- includes simple diagram
- contributes to the development of design criteria
- constructs the game or toy
- tests the game or toy based on given criteria
- identifies improvements to be made
- makes improvements
- works cooperatively
- shares group responsibilities

Peer Assessment of Design Presentation

Yes or No?

1. The speaker spoke so all could hear.
2. The speaker used visual aids or props.
3. The speaker clearly explained how the game or toy worked.
4. The speaker made me want to buy the toy or game.

Recommendations: _____

NOTES

Grade 3

Cluster 4: Soils and the Environment

Overview

Soil provides a base for gardens, forests, fields, and farms, supporting plant and animal life, and human activities. By examining soils, students discover that soil composition and characteristics vary. Students also experiment to determine the impact of different soils on plant growth, thus improving their understanding of scientific inquiry processes. Students also learn the importance of animals and nutrient recycling to soil quality. Teachers are encouraged to help students develop the strong connection between soils and plants (see *Grade 3, Cluster 1: Growth and Changes in Plants*).

PRESCRIBED LEARNING OUTCOMES

Students will...

3-4-01 Use appropriate vocabulary related to their investigations of soils in the environment.

Include: soil, soil component, loam, clay, sand, pebbles, organic matter, humus, rocks, sedimentation, sieving, water-holding capacity.

GLO: C6, D5

SUGGESTIONS FOR INSTRUCTION

- Introduce, explain, use, and reinforce vocabulary throughout this cluster.
- **I Wonder Chart**
Post lined chart paper that is entitled “Learning About Soils.” Invite students to record questions about this topic. Students may record questions, words, or phrases at any time throughout this study. Review the chart to reinforce vocabulary and use the questions to focus inquiry and instruction.

3-4-02 Identify and describe various components within a sample of soil from the local environment.

Examples: clay, loam, sand, pebbles, organic matter, humus, rocks...

GLO: D5

- **What Do I Know About Soils?**
To activate prior knowledge, have students brainstorm and list what they know (or think they know) about the composition of soil.

3-0-1a. Ask questions that lead to investigations of living things, objects, and events in the local environment. (ELA 1.2.4) GLO: A1, C2, C5

3-0-5e. Record observations in a variety of ways. *Examples: point-form notes, sentences, simple diagrams, charts...* (ELA 3.2.1, 3.3.2, 4.1.3; Math SP-II.2.1, SP-V.2.3) GLO: C2, C6

- **Composition of Soils**
Place pure samples of soil components (clay, sand, humus) in the Soil Science Centre. Have students visit the centre and use their senses to describe each sample. They should use a magnifying glass to observe particle size. Have students record their observations in a chart like the following.

Composition of Soils			
<u>Component</u>	<u>Looks Like</u>	<u>Feels Like</u>	<u>Smells Like</u>
clay	<u>grey</u>	<u>soft</u>	<u>a pond</u>
	<u>fine particles</u>		
sand	<u>golden</u>	<u>rough</u>	<u>fresh/no smell</u>
	<u>different sized particles</u>		
humus	<u>black and brown</u>	<u>crumbles</u>	<u>woody</u>
	<u>different sized particles</u>		

The category “Sounds Like” may be added to the above chart (muffled, rattles, etc.).

Discuss the observations with the class and ask students to include observations made by their peers in their own charts. Completed charts can be placed in science journals for future reference.

TEACHER NOTES

SUGGESTIONS FOR ASSESSMENT

Cluster Note: This cluster has a strong link to Grade 3, Cluster 1: Plants. Teachers may wish to address portions of both clusters during a unit of study.

This cluster also provides an excellent opportunity for students in rural areas to use agriculture as a focus. Contact your local Agriculture Manitoba office for resources and speakers.

Encourage students to use the term “soil,” rather than the less scientific term, “dirt.”

Soil has three main components:

Sand tiny fragments of rock (inorganic matter) that form the bulk of soil

Clay clay has much finer particles than sand

Humus decaying plant and animal matter (organic matter)

Soil can also contain larger rock pieces called pebbles, gravel, or silt. **Silt** is another variation in the size of rock fragments, being finer than sand, but coarser than clay. **Loam** is a fertile mixture of clay, sand, and humus.

Classroom soil samples can be created by combining the three components in various amounts and combinations and adding potting soil.

Paper and Pencil Task: Composition of Soils

Identify the three main components of soil and describe the characteristics of each.

The student identifies

- sand, clay, humus
- descriptive characteristics relating to the senses

PRESCRIBED LEARNING OUTCOMES
<i>Students will...</i>
<p>3-4-03 Explore to determine ways to separate soil components.</p> <p>Include: sedimentation and sieving techniques.</p> <p>GLO: C2, D5</p>
<p>3-0-4a. Carry out a plan, and describe the steps followed. (Math SP-V.2.3) GLO: C2</p> <p>3-0-4f. Assume roles and share responsibilities as group members. (ELA 5.2.1) GLO: C7</p> <p>3-0-5b. Use tools to observe, measure, and construct. Include: ruler, metre stick, pan balance, magnifying glass, bathroom scale, thermometer, magnet. (Math SS-I.1.3, SS-III.1.3, SS-IV.1.3, SS-VII.4.3) GLO: C2, C3, C5</p> <p>3-0-9c. Take the time to repeat a measurement or observation for greater precision or detail. GLO: C5</p>

SUGGESTIONS FOR INSTRUCTION

➤ **Investigation: Separating Soil Components**

Sieving/Screening

Have students explore how to separate the components of soil using a variety of screening devices (sieves, colanders, screens). Provide, or have the students bring, different-sized screens, sieves, and colanders. Have students make and record predictions as to what they think will remain in the sieve before they begin to separate and analyze soil components. Have students work in small groups and record observations in their science journals.

Sedimentation

Demonstrate for students how to separate the components of soil, using sedimentation. Provide each pair of students with a small glass jar (baby food or juice bottle). Have students put soil in the container (1/3 to 1/2 full), fill with water, put the lid on, shake vigorously, and allow soil to settle. Have students draw and label, in their science journals, a diagram that describes each separated layer. Have students summarize their findings using the following frame:

<p>This soil sample was made up of _____, _____, _____, _____, and _____.</p> <p>I know this because _____.</p>

Use the following questions for discussion:

- Was sieving or sedimentation more effective in separating soil components? Why?
- When might people use sieving to separate soil?
- When might people use sedimentation to separate soil?
- Why might people want to separate soil components?

TEACHER NOTES

SUGGESTIONS FOR ASSESSMENT

Self-Reflection: Separating Soil Components

1. I liked _____
_____.
2. I had a problem with _____
_____.
3. If I did this activity again, I would _____
_____.
4. I learned _____
_____.
5. I would like to learn more about _____
_____.

PRESCRIBED LEARNING OUTCOMES
<i>Students will...</i>
<p>3-4-04 Describe and compare components of soil samples collected at different locations and depths. GLO: D5, E1</p>
<p>3-0-3a. Brainstorm, with the class, one or more methods of finding the answer to a given question and reach consensus on which method to implement. GLO: C2, C7</p> <p>3-0-3c. Create, with the class, a plan to answer a given question. (ELA 3.1.4) GLO: C2, C7</p> <p>3-0-4a. Carry out a plan, and describe the steps followed. (Math SP-V.2.3) GLO: C2</p> <p>3-0-4h. Follow given safety procedures and rules, and explain why they are needed. GLO: C1</p> <p>3-0-5a. Make observations that are relevant to a specific question. GLO: A1, A2, C2</p> <p>3-0-5b. Use tools to observe, measure, and construct. Include: ruler, metre stick, pan balance, magnifying glass, bathroom scale, thermometer, magnet. (Math SS-I.1.3, SS-III.1.3, SS-IV.1.3, SS-VII.4.3) GLO: C2, C3, C5</p> <p>3-0-7a. Draw a simple conclusion based on their observations. GLO: A1, A2, C2</p>

SUGGESTIONS FOR INSTRUCTION

➤ **Investigating Soil Samples**

Have students collect both surface and below-the-surface soil samples from the school yard, home, neighbourhood, and beyond. Have students label the samples to identify their original location and depth. With students, decide on which method to use in order to separate soil components.

Surface

Have students work in pairs or small groups to analyze the surface samples and describe the components by using the senses of sight, touch, and smell. Encourage students to observe using a magnifying glass or microscope (if available). Have students record observations on a chart such as the one below.

Analyzing Soil Components

Location: Schoolyard

<u>Depth</u>	<u>Observations</u>	<u>Components Identified</u>
surface	_____	_____
below surface	_____	_____

Encourage students to look for signs of animals in their soil observations (link to 3-4-09).

Below the Surface

Have students analyze below-the-surface samples by following the same procedures they used for the surface samples. Students should add to their chart.

At the end of the learning experience, use the following focus questions for an analysis of the findings:

- Which component appeared most often? Least often?
- What did you discover about surface soil compared to soil below the surface?

TEACHER NOTES

SUGGESTIONS FOR ASSESSMENT

Soil is usually layered. The **topsoil** or upper layer is where humus, plant roots, and living creatures will be found. The more humus, the richer the soil. The next layer, called **subsoil**, often contains a high percentage of clay and may lack organic matter.

Self-Assessment of Observation Skills

I used the following senses to observe the soil samples:

- | | |
|----------------------------------|--------------------------------|
| <input type="checkbox"/> sight | <input type="checkbox"/> touch |
| <input type="checkbox"/> hearing | <input type="checkbox"/> smell |

I used the following tools:

- | | |
|---|-------------------------------------|
| <input type="checkbox"/> magnifying glass | <input type="checkbox"/> microscope |
| <input type="checkbox"/> other _____ | |

I observed the following things:

- | | |
|--------------------------------------|--------------------------------|
| <input type="checkbox"/> colour | <input type="checkbox"/> size |
| <input type="checkbox"/> texture | <input type="checkbox"/> shape |
| <input type="checkbox"/> other _____ | |

I recorded my observations using

- | | |
|-----------------------------------|--------------------------------------|
| <input type="checkbox"/> charts | <input type="checkbox"/> words |
| <input type="checkbox"/> diagrams | <input type="checkbox"/> other _____ |

PRESCRIBED LEARNING OUTCOMES
<i>Students will...</i>
<p>3-4-05 Compare the water-holding capacity of different soils.</p> <p><i>Examples: sandy soil retains far less water than loamy soil...</i></p> <p>GLO: D3, D5, E1</p>
<p>3-0-1b. Make predictions based on observed patterns, collected data, or data provided from other sources. (ELA 1.1.1; Math SP-IV.2.3) GLO: A1, C2</p> <p>3-0-5c. Estimate and measure mass/weight, length, volume, and temperature using standard units. (Math SS-IV.1.3, SS-I.1.3, SS-III.1.3, SS-VIII.4.3) GLO: C2, C3, C5</p> <p>3-0-6a. Display data using more than one way to represent the same data. (Math SP-III.2.3) GLO: C2, C6</p> <p>3-0-6b. Discuss data and generate new questions from displayed data. (Math SP-IV.1.2) GLO: A1, A2, C2, C5</p>

SUGGESTIONS FOR INSTRUCTION

➤ **Activating Prior Knowledge**

Use the following questions to stimulate thinking and generate discussion:

- When it rains, where does the water go?
- What happens if it rains for a very long time?
- What is absorption?
- Do all types of soils absorb the same amount of water?
- Why is absorption important?

➤ **Investigation: Observing the Amount of Water Soils Absorb**

Have the students work in small groups using soil samples from previous investigations. Put the same amount of soil into styrofoam cups that have drainage holes at the bottom. Hold each cup over a plastic cup in order to catch the water as it drips through the soil. Have students predict which soil will absorb the most water and which will absorb the least.

Work with each sample in turn. Add 15 ml of water at a time until the water begins to drip through the bottom drainage hole. This shows that the soil has reached its saturation point, and cannot hold any more water. Record the amount of water that was added to the soil before it reached saturation. Allow the sample to remain undisturbed for a set time. Measure the amount of water that dripped from the cup and subtract this from the amount added to show how much water the soil absorbed.

Repeat the procedure with at least two different soil samples.

Have students record the data on a chart.

Observing The Amount of Water Soils Absorb			
Type of Soil	1.	2.	3.
Amount of water added	_____	_____	_____
Amount of water that dripped through	_____	_____	_____
Amount of water absorbed	_____	_____	_____

Have students graph their data, discuss the findings, and generate new questions.

TEACHER NOTES

SUGGESTIONS FOR ASSESSMENT

In Grade 2, Cluster 2: Properties of Solids, Liquids, and Gases, students investigated the absorbency of different materials. The term **absorb** was used to indicate water being soaked up to the point where you can no longer see the water drops. Build on this working definition, adding terms such as **saturation** and **water-holding capacity**.

Sandy soils drain well because water can pass easily between the particles. Sandy soil does not hold water well and can dry out.

Clay soils have small particles and can prevent water from passing through them. Clay soil can become waterlogged.

Science Journal Entry: Water-Holding Capacity

Have students answer the following questions:

Your neighbours travel a great deal in their work. Their plants go a long time without being watered. They are going to add new soil to their plants. What soil would you recommend they use? Why?

Look for references to their findings in **Observing the Amount of Water Soils Absorb**.

PRESCRIBED LEARNING OUTCOMES

Students will...

3-4-06 Describe the effect of water on different soils.
Examples: texture, cohesion, ability to hold shape...
 GLO: D3, D5

3-0-4e. Respond respectfully to the ideas and actions of others, and recognize their ideas and contributions. (ELA 1.1.2, 5.2.2) GLO: C5, C7
3-0-4g. Verbalize questions, ideas, and intentions during classroom-learning experiences. GLO: C6
3-0-5e. Record observations in a variety of ways. *Examples: point-form notes, sentences, simple diagrams, charts...* (ELA 3.2.1, 3.3.2, 4.1.3; Math SP-II.2.1, SP-V.2.3) GLO: C2, C6

SUGGESTIONS FOR INSTRUCTION

➤ **Investigation: Observing the Effect of Water on Soils**

Provide students with several different soil samples. Each sample should be labelled. Have students work in pairs to add equal amounts of water to each sample until the soils are saturated. Have students observe, using their senses, and record their observations on the chart given below. Students then form each soil sample into similar shapes such as balls, flower pots, snakes or coils. Leave the finished samples undisturbed to dry and harden for a couple of days. When samples are dry have students observe using their senses and chart their findings.

How Water Affects Soil

Type of Soil

Saturated	<u>Looks Like</u>	<u>Feels Like</u>	<u>Smells Like</u>
1.	_____	_____	_____
2.	_____	_____	_____
3.	_____	_____	_____
Dried Out	<u>Looks Like</u>	<u>Feels Like</u>	<u>Smells Like</u>
1.	_____	_____	_____
2.	_____	_____	_____
3.	_____	_____	_____

Review the data and discuss the results with the class. Pose the following questions to focus the discussions:

- What effects did water have on the soil?
- Did you find that some soils were more cohesive than others? Why?
- Does the wet object feel different from the dry object? Why?
- Who would find it important to know how water affects different soils? (link to 3-4-08)

TEACHER NOTES

SUGGESTIONS FOR ASSESSMENT

A soil's **plasticity**, or capacity to stick together, is an indication of the amount and type of clay it contains. Manitoba's soil, often called Manitoba "gumbo," contains a large amount of clay.

PRESCRIBED LEARNING OUTCOMES
<i>Students will...</i>
<p>3-4-07 Conduct experiments to determine how different soils affect the growth of plants.</p> <p><i>Examples: compare the same type of plant grown in sand versus potting soil...</i></p> <p>GLO: A1, A2, C2, D2</p>
<p>3-0-1a. Ask questions that lead to investigations of living things, objects, and events in the local environment. (ELA 1.2.4) GLO: A1, C2, C5</p> <p>3-0-3a. Brainstorm, with the class, one or more methods of finding the answer to a given question and reach consensus on which method to implement. GLO: C2, C7</p> <p>3-0-3b. Identify, with the class, variables that have an impact on an investigation. GLO: A1, A2, C2, C7</p> <p>3-0-3c. Create, with the class, a plan to answer a given question. (ELA 3.1.4) GLO: C2, C7</p> <p>3-0-4a. Carry out a plan, and describe the steps followed. (Math SP-V.2.3) GLO: C2</p> <p>3-0-5a. Make observations that are relevant to a specific question. GLO: A1, A2, C2</p> <p>3-0-5d. Estimate and measure the passage of time using standard units. Include: seconds, minutes, hours. (Math SS-VI.1.3) GLO: C2, C3, C5</p> <p>3-0-7a. Draw a simple conclusion based on their observations. GLO: A1, A2, C2</p> <p>3-0-7b. Explain why conclusions related to classroom experiments should be based on multiple trials or classroom data rather than on an individual result. GLO: A1, A2, C2</p> <p>3-0-8a. Recognize that valid experiments normally have reproducible results, which may vary slightly. GLO: A1, A2, C2</p>

SUGGESTIONS FOR INSTRUCTION

➤ **How Soil Affects Plant Growth**

Ask students, “Are some soils better for growing indoor plants than others? Why or why not?” As a class, have students plan an investigation to answer the question. Have them identify variables that need to be controlled, including the following:

- amount of soil
- type of seed
- location
- amount of water
- type of container

As a class, identify the variables to be used for judging which plant grows the best (height, general appearance, number of leaves).

Have students soak bean seeds overnight, then plant them in a clear plastic cup that is labelled to indicate its soil type (sand, clay, loam, vermicompost, potting soil, schoolyard “dirt,” etc.). Attach another cup over the top with tape to create a mini-greenhouse. Have students observe their plant on a daily basis, over a two- to three-week period, and record their observations in a plant diary.

At the end of the observation period, use the following questions to focus discussion:

- Which soil produced the healthiest-looking plant?
- Why do you think this soil worked best?
- Would this soil produce the same results with a different kind of plant? Why or why not?
- What was the hardest variable to control?
- Why is it important to have more than one test planting for each type of soil?
- What might you do differently next time?

➤ **Observing the Environment**

Take students for a walk around the schoolyard and have them predict how the soils in different areas may be affecting the plants found there.

TEACHER NOTES

Have students use Blackline Master 2: Scientific Inquiry Recording Sheet: Grades 3 and 4.

While planning this experiment, students need to address the concept of a “fair test.” They must begin to recognize the factors or variables that must be kept the same in order to be able to draw reasonable conclusions. For example, if the plants were kept in different locations, it could be something other than soil type that affected their growth. Often students want to test several different things at once. They should be encouraged to focus on one aspect or variable at a time, and try to control all the other variables. This way, any differences observed can be more accurately attributed to the variable being studied (in this case, type of soil).

At the end of this experiment, students are asked to reflect on why more than one test plant for each type of soil was needed. Students should be encouraged to realize that with only one plant upon which to base a conclusion, there are many things that could go wrong. The seed itself might have been faulty, the cup may have been knocked over, etc. Scientists like to have more than one **trial**, or test sample, to identify faulty results.

Learning to modify existing plans is an important component of the design process.

SUGGESTIONS FOR ASSESSMENT

Observation Checklist: How Soil Affects Plant Growth

The student

- carries out the planned steps for seed planting
- accurately measures, records, and compares plant growth
- makes reasonable conclusions
- recognizes the importance and application of the results of the experiment
- asks questions for information or clarification when experimenting
- includes labelled diagrams
- identifies the variables that have an impact on the investigation
- recognizes that it is necessary to have more than one trial in an experiment

PRESCRIBED LEARNING OUTCOMES	SUGGESTIONS FOR INSTRUCTION
<p><i>Students will...</i></p>	
<p>3-4-08 Explain the importance of understanding the characteristics of different soils.</p> <p><i>Examples: enables farmers to determine which crops can be grown in a particular area, enables gardeners to improve plant growth, enables engineers to know what types of foundations to set for structures...</i></p> <p>GLO: A5, B1, B5, E2</p>	<p>➤ Who Needs to Know about Soils?</p> <p>Brainstorm a list of people or businesses that need to understand the characteristics of different soils. Show a video, read a book, or invite a guest speaker in to tell about the importance of understanding different types of soils and their characteristics.</p> <p>➤ Interviewing Experts</p> <p>Have students work with a partner to generate a list of questions to ask an expert (soil scientist, farmer, gardener, or greenhouse owner) about soils and plant growth. Have them interview one expert in person, via the Internet, by telephone, or fax. Help students summarize interview results. Have them draw a poster showing the expert they interviewed with his/her tools and workplace. (Link to 3-4-10 by having the experts talk about what they do with organic wastes.)</p>
<p>3-0-2a. Access information using a variety of sources. <i>Examples: children's magazines, local farmers, CD-ROMs, Internet...</i> (ELA 1.1.2, 3.2.2; Math SP-I.1.2.3; TFS 2.1.1) GLO: C6</p> <p>3-0-7e. Communicate results and conclusions in a variety of ways. <i>Examples: point-form lists, sentences, simple diagrams, charts, demonstrations...</i> (ELA 2.3.5, 3.3.2, 4.1.3; Math SP-III.2.3; TFS 2.1.4) GLO: C6</p>	
<p>3-4-09 Identify animals found in soil and explain their importance to soil quality.</p> <p><i>Examples: worms, insects, and mammals help to aerate the soil or increase nutrients...</i></p> <p>GLO: B5, D2</p>	<p>➤ Animal Helpers</p> <p>Ask the following questions:</p> <ul style="list-style-type: none"> • What kinds of animals did you find in soil samples? • What kinds of animals might you find in soil? • Are these animals useful to the soil? How? <p>Have students brainstorm a list of animals they have seen in their soil explorations. List other animals that may not have been seen. Have partners or small groups select an animal to research how it helps the soil. Have students present their findings to the class.</p>
<p>3-0-2a. Access information using a variety of sources. <i>Examples: children's magazines, local farmers, CD-ROMs, Internet...</i> (ELA 1.1.2, 3.2.2; Math SP-I.1.2.3; TFS 2.1.1) GLO: C6</p> <p>3-0-2b. Review information to determine its usefulness to research needs. (ELA 3.2.3, 3.3.3) GLO: C6, C8</p>	
<p>3-4-10 Describe ways to return organic matter to the soil.</p> <p><i>Examples: composting, spreading manure on fields...</i></p> <p>GLO: B1, B5, D2, D5</p>	<p>➤ Where Does Humus Come From?</p> <p>Discuss with the students what organic matter is and bring in samples of organic matter in order to help them visualize and understand the term (e.g., fruit peels, leaves, vegetable peels, etc.). Together, list ways that organic materials can be returned to the soil (e.g., spreading manure, leaving grass clippings, shredding leaves in the fall). Have students write a definition of organic materials in their science journals.</p>
<p>3-0-7a. Draw a simple conclusion based on their observations. GLO: A1, A2, C2</p> <p>3-0-7d. Examine how new experiences, ideas, and information connect to prior knowledge and experiences, and record these connections. (ELA 1.2.1, 2.1.2, 3.3.3) GLO: A2, C6</p>	

TEACHER NOTES

SUGGESTIONS FOR ASSESSMENT

Performance Assessment: Animal Helpers Research Scoring Rubric

Scale	Number of Sources	Includes Pictures or Diagram	Organization	Presentation
4	at least 3	yes	well-organized	good volume, clear information, and clear use of visual aids
3	at least 2	yes	complete and clear	good volume, clear use of visual aids
2	at least 1	perhaps	partially complete or complete but not thorough	good volume, limited information, no visual aids
1	1 only	perhaps	incomplete	good volume, limited information

Organic matter, decaying plant and animal remains, contains matter that was once living.

PRESCRIBED LEARNING OUTCOMES
<i>Students will...</i>
<p>3-4-11 Use the design process to construct a simple composter that returns organic matter to the soil.</p> <p><i>Examples: classroom composter for left-over food, school composter for grass clippings and leaves...</i></p> <p>GLO: B1, B5, C3, D2</p>
<p>3-0-1c. Identify practical problems to solve in the local environment. GLO: C3</p> <p>3-0-3d. Brainstorm, in small groups, possible solutions to a practical problem, and reach consensus on which solution to implement. GLO: C3, C7</p> <p>3-0-3e. Create, in small groups, a written plan to solve a problem or meet a need. Include: identify steps to follow, prepare a simple diagram. (ELA 1.2.3) GLO: C3, C7</p> <p>3-0-3f. Develop, in small groups, limited criteria to evaluate an object or device based on its function and aesthetics. GLO: C3, C7</p> <p>3-0-4b. Construct an object or device to solve a problem or meet a need. GLO: C3</p> <p>3-0-4c. Test an object or device with respect to pre-determined criteria. GLO: C3, C5</p> <p>3-0-4d. Identify and make improvements to an object or device, and explain the rationale for the changes. GLO: C3</p> <p>3-0-7c. Identify new problems that arise. GLO: C3</p> <p>3-0-8c. Recognize that designing a solution to a simple problem may have considerations, such as cost, materials, time, and space. GLO: B2, C3</p>
<p>3-4-12 Investigate how humans from various cultures use earth materials to make objects.</p> <p><i>Examples: clay pots, sod houses, adobe bricks, glass...</i></p> <p>GLO: A4, B1, B4</p>
<p>3-0-2a. Access information using a variety of sources. <i>Examples: children’s magazines, local farmers, CD-ROMs, Internet...</i> (ELA 1.1.2, 3.2.2; Math SP-I.1.2.3; TFS 2.1.1) GLO: C6</p> <p>3-0-6c. Place materials and objects in a sequence or in groups using two or more attributes, and describe the system used. (Math PR-I.1.3) GLO: C2, C3, C5</p>

SUGGESTIONS FOR INSTRUCTION

➤ **Design a Composter**

Sample design context: The class has decided that the school is producing too much garbage in the lunchroom. They wish to reduce the amount by composting organic materials. Prior to construction, students will need to research what happens during composting and different styles of composting. Existing plans for composters should be reviewed, but students should be encouraged to modify the plans or create their own. Several models may have to be tried in order to find one that is the appropriate size and configuration. Students also need to consider the cost of materials. Possible evaluation criteria include the following ideas:

- made of readily available materials
- sanitary
- easy to load and unload
- large enough to handle the organic wastes of two classes
- reasonable cost of materials

➤ **Picture Dictionary: It Comes from the Soil**

Ask students: How do humans use earth (soil) materials? Using a variety of sources, have the students work in small groups to research the use of earth materials in various cultures (e.g., sod houses, eating and cooking utensils, works of art, bricks, dikes, etc.).

Make a class picture dictionary entitled “It Comes from the Soil.” Have students draw or cut out a picture of the object with a label that identifies the country or culture of origin.

➤ **Expert Presenter**

Invite an artist who uses earth materials in his/her art into the classroom. The artist may be a glass blower, potter, sculptor, etc.

TEACHER NOTES

SUGGESTIONS FOR ASSESSMENT

Glass is made of sand that is melted together with limestone and sodium carbonate at 850° C. Clay is made up of fine particles of ground-up rock. The clay is shaped and baked in a kiln to make cups, pottery, bricks, etc.

Have students use Blackline Masters 4 and 4: Design Process Recording Sheet: Grades 3 and 4.

Design Process Checklist: Composter

The student

- identifies the problem
- brainstorms possible solutions
- creates a written plan
- develops design criteria
- constructs the composter
- tests the composter based on the criteria
- suggests and makes improvements to the composter
- works cooperatively
- presents the design to the group/class

Artists often make their own clay and use different types of components depending on the texture, colour, shape, translucency, etc., they want to achieve in their art.

NOTES

Grade 4 Science

Grade 4

Cluster 1: Habitats and Communities

Overview

As students in Grade 4 are familiar with the basic needs of plants and animals (see *Grade 2, Cluster 1: Growth and Changes in Animals*, and *Grade 3, Cluster 1: Growth and Changes in Plants*), they can begin to explore and compare ways in which plant and animal communities satisfy their needs in particular habitats. They begin to recognize the complex interactions that take place between plant and animal populations within a community. Through investigations, students study influences, both naturally occurring and human-caused, that can alter habitats and affect plant and animal populations. The cluster also addresses the roles traditional knowledge and technology play in learning more about and caring for plant and animal populations.

Kindergarten to Grade 4 Science: A Foundation for Implementation

PRESCRIBED LEARNING OUTCOMES	SUGGESTIONS FOR INSTRUCTION
<p><i>Students will...</i></p> <p>4-1-01 Use appropriate vocabulary related to their investigations of habitats and communities.</p> <p>Include: habitat, physical adaptation, behavioural adaptation, traditional knowledge, technological development, population, community, food chain, food web, organism, producer, consumer, herbivore, omnivore, carnivore, predator, prey, scavenger, endangerment, extinction, conservation.</p> <p>GLO: C6, D2</p>	<p>➤ Introduce, explain, use, and reinforce vocabulary throughout this cluster.</p> <p>➤ Word Wall</p> <p>Develop a Science Word Wall (Cunningham, 1991) with key vocabulary as the study ensues. Place the Word Wall where students will readily view it and use it as a reference. (See <i>ELA, Strategies</i>, p. 199.)</p>
<p>4-1-02 Recognize that each plant and animal depends on a specific habitat to meet its needs.</p> <p>GLO: D2</p> <p>4-1-03 Identify the components of an animal habitat.</p> <p>Include: food, water, living space, cover/shelter.</p> <p>GLO: D2, E2</p>	<p>➤ Meeting Needs</p> <p>Use Think-Pair-Share (McTighe and Lyman, 1992) to answer these discussion questions. (See <i>ELA, Strategies</i>, p. 15.)</p> <p>What does an animal need to survive? What does a plant need to survive? How do plants and animals meet their needs (link to Cluster 1, Grades 2 and 3)?</p> <p>➤ Oh Deer!*</p>
<p>4-0-6a. Construct bar graphs and pictographs using many-to-one correspondence, and interpret these as well as graphs from other sources. (Math SP-III.2.4) GLO: C2, C6</p> <p>4-0-6b. Identify and suggest explanations for patterns and discrepancies in data. GLO: A1, A2, C2, C5</p>	<p>Divide students into two groups (three quarters of the students in one group, and one quarter in the other). Mark two parallel lines on the ground or floor 9-18 metres apart. Have each group line up behind one line. The smaller group become “deer” and the larger group “habitat.” For each round, each “deer” decides which component of habitat it will require (except space) and it makes the appropriate sign. Once the sign for a round has been decided it can’t be changed until the next round. Signs include:</p> <ul style="list-style-type: none"> • food: clamp hands over the stomach • water: put hands over mouth • shelter: hold hands together over head <p>Each student in the “habitat” group also decides on a component for the round using the same signs as the “deer.” Each round starts with the “deer” facing away from the “habitat” group. Everyone decides on his or her sign. On a signal from the teacher, each “deer” student turns to face the “habitat” group and runs over to take the hand of a student with the matching habitat component sign. The “deer” bring the “habitat” students back to the deer line, indicating they successfully obtained what they needed. Any deer who cannot acquire the habitat component they need die and join the habitat group.</p> <p>Repeat for 10-15 rounds, keeping track of the deer population numbers. Have students graph the results from the game with each round representing one year, and suggest explanations for patterns in data.</p>

TEACHER NOTES

SUGGESTIONS FOR ASSESSMENT

Cluster Note: Many of the learning experiences in this cluster are based in the outdoors. Students should be provided with field trip opportunities, including trips to the schoolyard. More extended trips to local parks and camping trips would also provide excellent hands-on ways to address a number of learning outcomes within this cluster.

Habitat is where the animal or plant lives and is able to meet its basic needs. Habitat components include **food, water, space, cover/shelter**. A habitat can be as small as a puddle, or as large as a forest.

* Source for **Oh Deer!:** *Project Wild Activity Guide*, 1998. Adapted with the permission of the Canadian Wildlife Federation. Project Wild Training is available from Manitoba Natural Resources, Wildlife Branch, telephone: 204-945-7469. Participants are provided with the Project Wild Activity Guide.

Science Journal Entry: Oh Deer!

Student directions: Answer the following questions in your science journal:

1. What does an animal need in its habitat in order to survive?
2. What did you learn from the “Oh Deer!” activity? Give at least two answers.

Look for identification of the components of an animal habitat

- food water
- living space cover or shelter

The student

- discusses what happens when there is a shortage or absence of one of the components
- refers to the fact that the population is always changing

PRESCRIBED LEARNING OUTCOMES
<i>Students will...</i>
<p>4-1-04 Identify physical and behavioural adaptations of animals and plants, and infer how these adaptations help them to survive in a specific habitat.</p> <p><i>Examples: ducks' webbed feet and waterproof feathers help them dive for food in the marsh...</i></p> <p>GLO: D1, D2</p>
<p>4-0-2a. Access information using a variety of sources. <i>Examples: school libraries, videos, traditional knowledge, CD-ROMs, Internet...</i> (ELA 3.2.2, 3.2.4, TFS 2.1.1) GLO: C6</p> <p>4-0-2b. Review information to determine its usefulness to inquiry or research needs. (ELA 3.2.3, 3.3.3) GLO: C6, C8</p> <p>4-0-5a. Select and use tools to observe, measure, and construct. <i>Examples: tuning fork, prism, binoculars, measuring tape...</i> GLO: C2, C3, C5</p> <p>4-0-7e. Communicate results and conclusions in a variety of ways. <i>Examples: point-form lists, sentences, graphs, labelled diagrams, charts...</i> (ELA 2.3.5, 4.2.5; Math SP-III.1.4, SP-III.2.4; TFS 2.1.4) GLO: C6</p>

SUGGESTIONS FOR INSTRUCTION

➤ **It's for the Birds**

Have students complete small-group inquiries into the physical and behavioural adaptations of birds.

1. PHYSICAL ADAPTATIONS

Provide the class with common beak shapes (see teachers notes) and feet types of birds and have students complete the information on the charts. Students should be expected to find out through their research the information included in parentheses.

Beaks

<u>Beak Shape</u>	<u>Type of Food</u>	<u>Birds with this Beak</u>
long narrow	(flower nectar)	(hummingbird)
hooked	(flesh-eating)	(hawk)
chisel	(tree insects)	(woodpecker)
strainer	(pond plants, insects)	(duck)
stout	(hard seeds)	(blue jay)

Feet

<u>Feet Types</u>	<u>Birds with these Feet</u>
grasping feet	(hawk)
perching claws	(sparrow)
tree-climbing	(woodpecker)
webbed	(duck)

2. BEHAVIOURAL ADAPTATIONS

Name of bird: robin

<u>Seasonal Behaviour</u>	<u>Obtains Food by</u>	<u>Avoids Enemies by</u>
migrates in winter	searching ground for worms	flying away

Students should present the findings of their inquiries to the class, highlighting how particular adaptations are linked to particular habitats and behaviours.

(continued)

TEACHER NOTES

SUGGESTIONS FOR ASSESSMENT

These learning experiences focus on birds. Plant adaptations can be addressed in learning experiences suggested for student learning outcome 4-1-07.



long and narrow



hooked



chisel



strainer



stout

(continued)

**B
E
A
K
T
Y
P
E
S**

Self-Assessment: It's for the Birds

Name: _____ Date: _____

Adaptation Research Project

What Did I Learn?

I chose to research a _____ (bird).

1. One problem I had was _____

_____.

2. One thing I did well was _____

_____.

3. If I did this project again I would _____

_____.

4. I would like to learn more about _____

_____.

5. I think my project _____

_____.

PRESCRIBED LEARNING OUTCOMES

SUGGESTIONS FOR INSTRUCTION

Students will...

➤ **Bird Observations**

Have students use the categories below to record information about birds they observe. The information can be recorded in the form of words, sketches, or whatever is most meaningful in describing the bird and its behaviour. Initially, students can observe birds in the schoolyard or a local wooded area. Once students are comfortable with the process, they can observe birds on their own. Example:

<u>Size</u>	<u>Colour Markings</u>	<u>Beak Shape</u>	
sparrow, robin, or crow-sized	throat, belly, wings, tail	_____	
<u>Tail Shape</u>	<u>Surroundings</u>	<u>Flight</u>	<u>Song</u>
_____	_____	_____	_____

Provide resources to help students identify common local birds based on the charted information. Keep a class list of birds observed.

4-1-05 Investigate alternate explanations of plant or animal adaptations based on traditional knowledge from a variety of cultures.

GLO: A1, A4, C8

4-1-06 Investigate how technological developments often mirror physical adaptations.

Examples: fishnet — spider web, diving fins — webbed feet...

GLO: A5, E1

➤ **Traditional Perspectives**

Have students read stories which provide explanations for plant and animal adaptations from a traditional cultural perspective. Encourage students to select stories about the plants or animals they researched. Have students share these traditional stories with their research presentations. (See *ELA, Grade 4*, pp. 80-83.)

➤ **Using Animal Adaptations**

As a class, brainstorm and list technological devices that resemble physical adaptations for animals. Record the information on a chart.

<u>Animal's Adaptation</u>	<u>Technological Artefact</u>
webbed feet	swimming fins
thorns	barbed wire
fish's body	canoe

4-0-7d. Construct meaning in different contexts by connecting new experiences and information to prior experiences and knowledge. (ELA 1.2.1, 2.1.2) GLO: A2, C6

4-0-7e. Communicate results and conclusions in a variety of ways. *Examples: point-form lists, sentences, graphs, labelled diagrams, charts...* (ELA 2.3.5, 4.2.5; Math SP-III.1.4, SP-III.2.4; TFS 2.1.4) GLO: C6

4-0-9a. Respect alternative views of the world. (ELA 5.1.1) GLO: C5, C7

TEACHER NOTES

SUGGESTIONS FOR ASSESSMENT

Physical adaptations refer to the physical characteristics of a plant or animal that enable it to survive in the environment in which it lives.

Behavioural adaptations are the ways the animal acts or behaves in order to survive.

Paper and Pencil Task: Traditional Perspectives

Student directions: Choose a plant or animal. Look at the adaptations that help it survive in its habitat. Make up your own “traditional” story to explain how one or more of these adaptations came to be.

Look for

- adaptation(s) identified
- explanation is clear and creative

PRESCRIBED LEARNING OUTCOMES
<i>Students will...</i>
<p>4-1-07 Investigate and describe a variety of local and regional habitats and their associated populations of plants and animals.</p> <p>GLO: D2, E2</p>
<p>4-0-5a. Select and use tools to observe, measure, and construct. <i>Examples: tuning fork, prism, binoculars, measuring tape...</i> GLO: C2, C3, C5</p> <p>4-0-5c. Record observations in a variety of ways. <i>Examples: point-form notes, sentences, labelled diagrams, charts...</i> (ELA 2.1.1, 3.3.1, 4.1.1, 4.1.2; Math SP-1.2.4, SP-II.2.4) GLO: C2, C6</p> <p>4-0-6c. Choose and identify relevant attributes for use in a classification system, and create a chart or diagram that shows the method of classifying. (Math PR-II.2.4) GLO: C2, C3, C5</p> <p>4-0-7a. Draw a conclusion based on evidence gathered through research and observation. GLO: A1, A2, C2</p> <p>4-0-7b. Identify new questions that arise from what was learned. (ELA 3.3.4) GLO: A1, C2, C3</p>
<p>4-1-08 Predict and test to determine an appropriate method for measuring a plant population within a given habitat.</p> <p>GLO: A2, C2, C3, C5</p>
<p>4-0-5b. Estimate and measure mass/weight, length, volume, area, and temperature using standard units. (Math SS-IV.1.4, SS-I.1.4, SS-III.1.4, SS-II.1.4) GLO: C2, C3, C5</p> <p>4-0-3a. Brainstorm, in small groups, one or more methods of finding the answer to a given question, and reach consensus on which method to implement. GLO: C2, C7</p> <p>4-0-3c. Create, in small groups, a plan to answer a given question. (ELA 3.1.4; Math SP-V.2.4) GLO: C2</p> <p>4-0-4a. Carry out a plan, and describe the purpose of the steps followed. (Math SP-V.2.4) GLO: C2</p> <p>4-0-6e. Evaluate, with guidance, the methods used to answer a question or solve a problem. GLO: C2, C3</p>

SUGGESTIONS FOR INSTRUCTION

- **Observing the Environment: Habitats Are Everywhere**

Make several successive visits to a local habitat to observe and identify plants and animals. Students will need to look for signs that animals live there. Local habitats may include the schoolyard, a local park, or a property adjacent to the schoolyard. Have students record animals and plants that live in that habitat. Use the following discussion questions:

 - What populations did you observe?
 - How were their needs met in that habitat?

- **Habitat Sort**

Have students bring in pictures representing different Manitoba habitats such as prairie, desert, boreal forest, marsh, tundra, and the Canadian Shield. Students should sort their pictures and share their decisions about their groupings. As a class, identify and list the main characteristics of each group. Use this opportunity to discuss the adaptations of plants in diverse habitats e.g., desert or marsh. (Link to 4-1-04.)

- **Populations Field Study**

Tell students that they need to find out the number of each kind of plant within a given habitat. Begin by identifying a habitat such as a portion of the schoolyard, a park, etc. and the common plants (e.g., dandelions) found there. Ask students to predict the number of each type of plant that will be found in the area and then decide on a way to check their predictions.

Have students work in small groups to decide on a procedure to find the plant populations and carry out their plan.

Make a variety of tools such as skipping ropes, metre sticks, and string available for measuring and delimiting areas. Students will naturally think they need to count every individual plant within the study area. Make sure that you choose a large enough area so that counting each plant would be very time-consuming. Challenge students to think of other quicker ways to determine a “ball-park” population figure through sampling.

Following the population study, have students evaluate and report on the methods used. Have a biologist visit the class to discuss how scientists determine plant and animal population numbers in the wild.

TEACHER NOTES

Students will need more than one visit to a local habitat in order to observe things they may have missed during previous visits.

It is recommended that classrooms have at least one habitat for students to observe and care for. Consider a terrarium, aquarium, vermiculture, or mealworm box. Another suggested habitat is a “Pond in a Bottle,” which uses a two-litre pop bottle, mud, pond water, and pond plants and organisms.

The concept of a ratio and proportion is not a Grade 4 topic in mathematics. Formal calculations, formulas, etc., are not intended to be given to students. Student-developed strategies are to be encouraged and valued.

SUGGESTIONS FOR ASSESSMENT

Performance Task: Habitats (Outcomes 4-1-04 and 4-1-07)

Student directions: Use your imagination to create a new habitat. Describe your habitat. Design an animal for your habitat. Explain how this animal is adapted to its habitat by describing how it meets its needs. Include a labelled diagram.

Scoring Rubric:

Scale	Habitat	Adaptations	Communication
4	imaginative, application of prior knowledge related to habitats evident	at least four adaptations given suitable for created habitat, enable animal to meet its needs	explanation clear and detailed, labelled diagram included
3	original, description given, application of prior knowledge related to habitats evident	three adaptations given suitable for created habitat, enable animal to meet its needs	explanation clear and detailed, labelled diagram included
2	original, brief description given, limited evidence of prior knowledge related to habitats	two adaptations given, suitable for created habitat, little or no explanation of how animal meets needs	explanation incomplete or unclear, labelled diagram may be included
1	limited description given, habitat not original	one adaptation given, suitable for habitat, no explanation of how animal meets its needs	explanation incomplete or unclear, labelled diagram may be included

PRESCRIBED LEARNING OUTCOMES
<i>Students will...</i>
<p>4-1-09 Recognize that plant and animal populations interact within a community. GLO: D2</p>
<p>4-1-10 Recognize that the food chain is a system in which some of the energy from the Sun is transferred eventually to animals. GLO: D2, D4, E2</p>
<p>4-1-11 Construct food chains and food webs, and classify organisms according to their roles. Include: producer, consumer, herbivore, omnivore, carnivore, predator, prey, scavenger. GLO: D2, E2</p>
<p>4-0-4f. Assume roles, and share responsibilities as group members. (ELA 5.2.2) GLO: C7 4-0-6c. Choose and identify relevant attributes for use in a classification system, and create a chart or diagram that shows the method of classifying. (Math PR-II.2.4) GLO: C2, C3, C5 4-0-6d. Sort and classify according to an established classification system. (Math PR-II.2.4) GLO: C2, C3 4-0-7d. Construct meaning in different contexts by connecting new experiences and information to prior experiences and knowledge. (ELA 1.2.1, 2.1.2) GLO: A2, C6</p>

SUGGESTIONS FOR INSTRUCTION

➤ **Classifying and Sorting Animals**

Provide a list (or pictures) of animals and have students work in small groups to place animals into categories according to what they eat. Have students share their categories and discuss discrepancies (see *Success for All Learners*, 6:33-35). Provide students with the scientific terminology for their classifications.

Have students re-write the list of animals for use in a Venn diagram using the labels herbivores, carnivores, and omnivores (overlapping area). Have students add other animals to the list.

Use the original list of animals to construct food chains, which show simple linear relationships based on who eats whom or what. Students can develop more complex food webs, e.g., seeds, mouse, fox, as they gain experience with food chains.

➤ **Game — Food Web**

Assign each student a name of a population; include **producers** (grass, seeds), **herbivores** (deer, rabbits), **omnivores** (bears, raccoons), **carnivores** (wolves), **scavengers** (ravens), and the **Sun**. The ratio of the species should be approximately: 7 grass, 4 seeds, 4 rabbits, 3 deer, 1 bear, 2 raccoons, 4 wolves, 3 raven, and 1 Sun. There should be more producers and herbivores than carnivores and scavengers. Students sit in a circle and pass a ball of yarn at random from person to person. Each person must hold tightly to the yarn.

Describe a scenario such as: “There was a bad drought this year and the grass was stunted.” Students assigned the word “grass” must drop the yarn. As soon as other students feel one of their ends loosen, they must drop the yarn as well. Describe other scenarios. Include the removal of the Sun.

Use the following questions to focus discussion after the game:

- What happened to our food chains when the Sun was removed?
- Why were the plants affected?
- How did this affect the other animals?
- Where does the Sun’s energy go?

➤ **Journal Reflection**

Have students use their science journals to reflect on the differences in how plants and animals obtain their food (energy) for survival.

TEACHER NOTES

Animals can be classified as producers or consumers based on how they obtain their food.

Producers (plants) make their own food using energy from the Sun.

Consumers need to eat plants or animals for their food. Other terms are used to describe the different types of consumers:

herbivore - plant eater

carnivore - flesh eater

omnivore - eats both plants and flesh

Other terms are used to describe an animal's role. Carnivores can be **predators** (hunters) or **scavengers** (eating the remains of other animals). **Prey** refers to the animals that are eaten by other animals.

The Manitoba Fisheries Sustainable Development website provides teacher background information and instructional suggestions related to food chains for Manitoba fish species. The website is located at <www.gov.mb.ca/natres/sustain/index.html>

SUGGESTIONS FOR ASSESSMENT

Student Interview: Food Chains

Before the interview, gather pictures of various components of different food chains.

Student directions:

1. Use some of the pictures to make a food chain.
2. Tell something about each part of your food chain.

The student identifies

- | | | |
|------------------------------------|------------------------------------|------------------------------------|
| <input type="checkbox"/> producer | <input type="checkbox"/> predator | <input type="checkbox"/> omnivore |
| <input type="checkbox"/> carnivore | <input type="checkbox"/> herbivore | <input type="checkbox"/> scavenger |
| <input type="checkbox"/> consumer | <input type="checkbox"/> prey | |

(If students don't use the terms, ask them directly: Where is the predator, prey, producer, etc., in your food chain?)

3. Keep the same food chain. Add other pictures to make a food web.
4. Where does the energy for a food chain come from? (The Sun)

Record responses. Note any misconceptions or gaps in student's learning.

PRESCRIBED LEARNING OUTCOMES
<i>Students will...</i>
<p>4-1-12 Use the design process to construct a model of a local or regional habitat and its associated populations of plants and animals. GLO: C3, D4</p>
<p>4-0-3d. Brainstorm possible solutions to a practical problem, and identify and justify which solution to implement. (ELA 1.2.3) GLO: C3</p> <p>4-0-3e. Create a written plan to solve a problem or meet a need. Include: identify steps to follow, prepare a labelled diagram. GLO: C3</p> <p>4-0-3f. Develop criteria to evaluate an object, device, or system based on its function, aesthetics, and other considerations such as materials, and cost. GLO: C3</p> <p>4-0-4b. Construct an object, device, or system to solve a problem or meet a need. GLO: C3</p> <p>4-0-4c. Test an object, device, or system with respect to pre-determined criteria. GLO: C3, C5</p> <p>4-0-4h. Use tools and apparatus in a manner that ensures personal safety and the safety of others. GLO: C1</p> <p>4-0-7e. Communicate results and conclusions in a variety of ways. <i>Examples: point-form lists, sentences, graphs, labelled diagrams, charts...</i> (ELA 2.3.5, 4.2.5; Math SP-III.1.4, SP-III.2.4; TFS 2.1.4) GLO: C6</p>

SUGGESTIONS FOR INSTRUCTION

➤ **Design Project**

Have students work in groups to construct a model representing a local or regional habitat of their choice. Remind students to ensure that their models are realistic, including representative populations and the components necessary for the populations to live. The models must also strive to demonstrate the balance in nature. Have students present their model to the class.

TEACHER NOTES

SUGGESTIONS FOR ASSESSMENT

Part of the challenge for this learning experience is for students to determine what materials they will use to construct their model or diorama. In earlier grades, materials were usually determined by the teacher. This is a good opportunity to leave the determination of materials up to the students as an important component of the design process.

Have student use Blackline Master 4: Design Process Recording Sheet: Grades 3 and 4

Observation Checklist: Design Process

The student

- actively participates in brainstorming solutions
- creates a written plan or a labelled diagram
- assists in development of criteria
- constructs a habitat model
- tests the model with respect to evaluation criteria
- makes improvements
- communicates results

Peer Assessment: Design Presentation

Rate each of the following:

The speaker spoke so everyone could hear.

The speaker explained how the design was constructed.

The speaker explained how the design met the criteria.

The speaker kept the interest of the group.

	Yes	No	Comments
The speaker spoke so everyone could hear.			
The speaker explained how the design was constructed.			
The speaker explained how the design met the criteria.			
The speaker kept the interest of the group.			

PRESCRIBED LEARNING OUTCOMES
<i>Students will...</i>
<p>4-1-13 Predict, based on their investigations, how the removal of a plant or animal population may affect the rest of the community.</p> <p><i>Examples: if the wolves were removed from a community, the deer population may increase rapidly...</i></p> <p>GLO: D2, E2, E3</p>
<p>4-0-1b. Make and justify predictions based on observed patterns, collected data, or data provided from other sources. <i>Examples: graph, chart...</i> (ELA 1.1.1, 1.2.1; Math PR-III.1.4) GLO: A1, C2</p> <p>4-0-4g. Communicate questions, ideas and intentions, and listen effectively to others during classroom-learning experiences. GLO: C6</p>
<p>4-1-14 Investigate natural and human-caused changes to habitats, and identify resulting effects on plant and animal populations.</p> <p>Include: endangerment, extinction.</p> <p>GLO: B1, B5, D2, E3</p> <p>4-1-15 Describe how their actions can help conserve plant and animal populations and their habitats.</p> <p><i>Examples: clean up a local stream to improve fish and bird habitat...</i></p> <p>GLO: B5</p>
<p>4-0-4e. Identify problems as they arise, and work with others to find solutions. GLO: C3, C7</p> <p style="text-align: right;">(continued)</p>

SUGGESTIONS FOR INSTRUCTION

➤ **Food Web Game**

Have students take part in this variation of the Food Web Game (see p. 4.10). In this game students create food webs by combining several food chains. One student starts with the string and names a producer. The student then passes the string to someone else who names a consumer that would “eat” the first student. Students continue to pass the string to other consumers, keeping it taut, until the food chain is completed. The same process begins again with another student and another string. As more food chains are added, the already identified producers and consumers can also take the string as part of another food chain. Several food chains should be completed with students taking part in more than one to show the interrelationships in a food web.

Use the following questions to focus discussion after the game:

- What will happen if one of the components of a food chain is removed?
- What will happen if two components of the food chain are removed?
- Can you remove any of the components without altering the food chain?

Game Variations

Based on the discussion questions, investigate what would happen if one component was removed. Have one student release the taut string and observe students to find out which scenario would have the most dramatic effect (producers).

➤ **Natural and Human-Caused Changes**

Have students create a list of natural agents of changes and human agents of change on the environment. The list may include examples such as the following.

<u>Natural Agents of Change</u>	<u>Human Agents of Change</u>
Insect infestations- tent caterpillars	Logging
Dutch Elm Disease	Mosquito fogging
Purple loosestrife (Lithrium)	Use of pesticides
Damming by beavers	Draining wetlands
Fire	Industrial waste
Drought	Zebra mussels importation
Flood	Oil spills

Have students work with partners to research impacts of these changes on animal and plant populations. Post and discuss.

(continued)

TEACHER NOTES

SUGGESTIONS FOR ASSESSMENT

Paper and Pencil Task: Disappearing Animal Population

Present students with the following scenario: In Evergreen National Park scientists have noticed a gradual decline in the number of wolves sighted. You are a research scientist and have been asked to investigate what effect the disappearance of wolves has had on other populations within the park and to summarize your findings in an article for the local newspaper. Write the article.

Look for

- increase in the population(s) of animals that wolves prey on (deer, rabbit, mouse, etc.)
- decrease in the amount of food available for the wolves' prey
- clearly written article covering who, what, when, where, why

PRESCRIBED LEARNING OUTCOMES

SUGGESTIONS FOR INSTRUCTION

Students will...

4-0-4f. Assume roles, and share responsibilities as group members. (ELA 5.2.2) GLO: C7
4-0-4g. Communicate questions, ideas and intentions, and listen effectively to others during classroom-learning experiences. GLO: C6

➤ **Green School: Habitat Protection**

Identify and become aware of examples of programs designed to protect habitats, such as Ducks Unlimited, Habitat Trust, Save our Seine, Manitoba Wildlife Federation, and designated parkland and conservation areas.

Have students plan a school-based activity that aids in conservation of animals, plants, or habitats.

Have students create a multimedia advertisement and/or presentation (including a jingle, rap, commercial) on their conservation/protection plan.

4-1-16 Describe how specific technological developments have enabled humans to increase their knowledge about plant and animal populations.
Examples: radio collar tracking, time-lapse photography...
 GLO: A2, A3, A5

4-1-17 Recognize and appreciate how traditional knowledge contributes to our understanding of plant and animal populations and interactions.
 GLO: A1, A2, A4, C8

➤ **Guest Presenters**

Invite wildlife experts, conservation officers, and local elders to share their knowledge of plants and animals (link to 4-1-17).

Have students use their science journals to reflect on how both technology and traditional knowledge can help us better understand plant and animal populations.

➤ **Technological Developments**

Have students collect current articles from the Internet, newspapers, and magazines about how technology is used for the preservation and conservation of wildlife. Examples may include: medicine, embedded microchips for pet and farm animal identification, radio collar tracking, Global Positioning Systems, satellite imaging, environmental impact studies, etc. Use a Jigsaw strategy (Aronson et. al.) to facilitate students' understanding. (Note: Jigsaw is discussed in *Success for All Learners*, 5.9.)

4-0-2a. Access information using a variety of sources. *Examples: school libraries, videos, traditional knowledge, CD-ROMs, Internet...* (ELA 3.2.2, 3.2.4, TFS 2.1.1) GLO: C6
4-0-9a. Respect alternative views of the world. (ELA 5.1.1) GLO: C5, C7

➤ **Field Trip: Traditional Cultures**

Visit locations such as the Fort Whyte Centre, Spirit Sands, Living Prairie Museum, Sandilands, Manitoba Museum of Man and Nature or any other museum that provides information about traditional cultures and the balance of nature. Have students view displays, record observations, and discuss how traditional knowledge helps us understand how plant and animal populations interact. Examples might include some of the following:

- using caribou migration routes to help plan where to find caribou to hunt
- knowing when fish are spawning in the water in order to catch fish and hunt bears
- observing animal and plant patterns to judge seasonal changes

TEACHER NOTES

SUGGESTIONS FOR ASSESSMENT

NOTES

Grade 4

Cluster 2: Light

Overview

In previous grades, students had an informal introduction to energy. In this cluster, students begin to examine in more depth one form of energy they encounter on a daily basis — light. In *Grade 4, Cluster 3: Sound*, students study another aspect of energy — sound. Whether these clusters are addressed separately or as part of a combined unit, the emphasis is on building an understanding of energy. Students become familiar with the properties of light by investigating and observing how light interacts with various objects in the environment. From these observations, students come to recognize that light travels in a straight line, knowledge which they will apply, along with their design-process skills, to the construction of simple optical devices.

PRESCRIBED LEARNING OUTCOMES

SUGGESTIONS FOR INSTRUCTION

Students will...

4-2-01 Use appropriate vocabulary related to their investigations of light.
 Include: energy, reflect, absorb, transmit, artificial, light beam, transparent, translucent, opaque, technological development, science, brightness.
 GLO: A5, B1, C6, D4

➤ Introduce, explain, use, and reinforce vocabulary throughout this cluster.

4-2-02 Give examples of various forms of energy.
 Include: light, heat, food, sound.
 GLO: D4, E4

4-2-03 Recognize that energy is an integral part of daily life.
 GLO: B1, D4, E4

➤ **Forms of Energy**
 Use a Thinking Map to assist recall and organization of prior knowledge and to develop shared knowledge about various forms of energy. (Note: Thinking Maps are discussed in *ELA, Strategies*, p. 49.) Example:

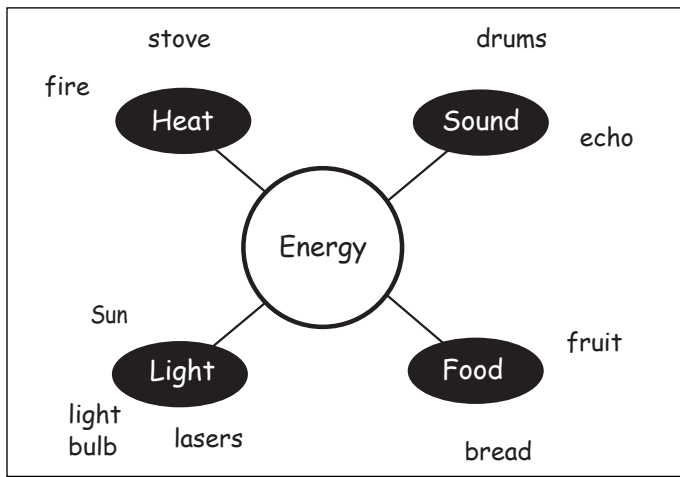

4-0-4e. Identify problems as they arise, and work with others to find solutions. GLO: C3, C7

4-0-6d. Sort and classify according to an established classification system. (Math PR-II.2.4) GLO: C2, C3

4-0-7e. Communicate results and conclusions in a variety of ways. *Examples: point-form lists, sentences, graphs, labelled diagrams, charts...* (ELA 2.3.5, 4.2.5; Math SP-III.1.4, SP-III.2.4; TFS 2.1.4) GLO: C6

➤ **Observing the Environment — Finding Energy**
 Have students work in pairs to list examples of energy found in their school building and schoolyard. Students then work with another pair to sort and categorize the energy examples according to the form of energy. Students may put the same example into more than one category. Use a Sharing Circle to have each group share their chart. (Note: Sharing Circle is discussed in *ELA, Strategies*, p. 106.)

➤ **Light Energy**
 Have students draw pictures in their science journals representing light as a form of energy.

TEACHER NOTES

SUGGESTIONS FOR ASSESSMENT

Planning Note: Outcomes 4-2-02 and 4-2-03 are similar to outcomes 4-3-02 and 4-3-03 in Cluster 3: Sound. If the class has already studied sound energy, a quick review of energy with a “light” focus would be sufficient.

Energy is a very important, yet challenging concept in science. It is recommended that students at this level talk about and use the term “energy” before they are able to define it. An appropriate working definition would be that energy makes things go, run, or happen. (See American Association for the Advancement of Science, *Benchmarks for Science Literacy*, p. 81.)

In later years, students will work towards the more formal definition of energy as the ability to do work. Energy can be identified through things such as movement, heat, electricity, magnetic attraction, gravity, sound, and light. Energy can also be stored and used at later times (potential energy).

Science Journal Entry: Energy

Student directions: In your science journal, draw four pictures to show a variety of forms of energy found in your home. Be sure to label your pictures with the form of energy and its location.

Look for

- four pictures drawn
- clearly labelled
- a variety of energy forms shown
- work neatly done

PRESCRIBED LEARNING OUTCOMES

SUGGESTIONS FOR INSTRUCTION

Students will...

4-2-04 Demonstrate that white light can be separated into colours.
GLO: C2, D4

4-0-7a. Draw a conclusion based on evidence gathered through research and observation.
GLO: A1, A2, C2

4-0-7b. Identify new questions that arise from what was learned. (ELA 3.3.4) GLO: A1, C2, C3

4-2-05 Distinguish between objects that produce their own light and those that reflect light from another source.
Examples: the Sun emits its own light, the Moon reflects light from the Sun...
GLO: A1, A2, D4

4-2-06 Identify a variety of natural and artificial light sources.
Examples: Sun, candle, light bulb, firefly, lightning, aurora borealis, lasers...
GLO: D4

4-0-4g. Communicate questions, ideas and intentions, and listen effectively to others during classroom-learning experiences. GLO: C6

4-0-6d. Sort and classify according to an established classification system. (Math PR-II.2.4) GLO: C2, C3

➤ **Investigating Colours**

Have students hold a prism in sunlight to observe the colour of the rays that are separated onto a white paper background.

Ask the following questions:

- What do you see when the light passes through the prism?
- Are the colours all the same? What are the colours?
- Why does this happen?
- What does this tell you about white light?

➤ **Produce or Reflect?**

Have students work in small groups to sort a variety of pictures into two categories. Provide a word list and categories. (See *Success for All Learners*, 6.33-6.35.)

<u>Produce Own Light</u>	<u>Reflect Light from Other Sources</u>
fireflies	bicycle reflector
Sun	moonlight on water
stars	planets
light bulb	Moon

Have students share their categorizations.

➤ **Natural or Artificial?**

As a class, brainstorm and list a large number of sources of light. Have students work in small groups to categorize items as having natural or artificial light. Students may add other items as they work together. Have students share their work with classmates.

➤ **Carroll Diagram**

Have students revisit their lists from **Natural or Artificial?** and regroup these items according to the new variable of either producing or reflecting light.

	Natural	Artificial
produces light		
reflects light		

TEACHER NOTES

Caution: Ensure the students do not look directly at the Sun.

Visible white light is made up of the colours of the rainbow: red, orange, yellow, green, blue, indigo, and violet (Roy G. Biv). A prism (or even a glass of water) helps to separate out all the colours within white light.

SUGGESTIONS FOR ASSESSMENT

Paper and Pencil Task: Light Sources

1. Give four examples of objects that produce their own light.
2. Give four examples of objects that reflect light from other sources.
3. What is the difference between natural and artificial light?
4. Sort the following light sources using the Venn diagram.
 - fireflies
 - light bulb
 - candle
 - flashlight
 - Sun
 - Moon
 - stars
 - mirror
 - lightning

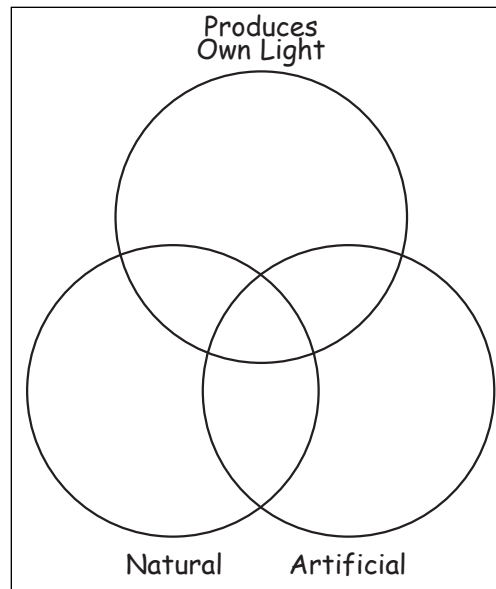

PRESCRIBED LEARNING OUTCOMES
<i>Students will...</i>
<p>4-2-07 Observe and describe properties of light. Include: travels in a straight path, bends as it passes from one medium to another, can be reflected, can be different colours. GLO: C2, D4</p> <p>4-2-08 Explore to determine effects different materials and objects have on a light beam. <i>Examples: prisms and water bend light; some lenses intensify light, whereas others disperse light...</i> GLO: C2, D3, D4</p>
<p>4-0-1a. Ask questions that lead to investigations of living things, objects, and events in the local environment. (ELA 1.2.4, 3.1.2) GLO: A1, C2, C5</p> <p>4-0-1b. Make and justify predictions based on observed patterns, collected data, or data provided from other sources. <i>Examples: graph, chart...</i> (ELA 1.1.1, 1.2.1; Math PR-III.1.4) GLO: A1, C2</p> <p>4-0-4f. Assume roles, and share responsibilities as group members. (ELA 5.2.2) GLO: C7</p> <p>4-0-4h. Use tools and apparatus in a manner that ensures personal safety and the safety of others. GLO: C1</p> <p>4-0-5c. Record observations in a variety of ways. <i>Examples: point-form notes, sentences, labelled diagrams, charts...</i> (ELA 2.1.1, 3.3.1, 4.1.1, 4.1.2; Math SP-1.2.4, SP-II.2.4) GLO: C2, C6</p> <p>4-0-7a. Draw a conclusion based on evidence gathered through research and observation. GLO: A1, A2, C2</p> <p>4-0-8a. Recognize that experimental results may vary slightly when carried out by different persons, or at different times or places; but that if the results of repeated experiments are very different, something must be wrong with the design of the experiment. GLO: A1, A2, C2</p> <p>4-0-9c. Report and record what is observed, not what they think they ought to observe, nor what they believe the teacher expects. GLO: C5</p>

SUGGESTIONS FOR INSTRUCTION

➤ **Properties of Light**

Use a KWL strategy (Ogle, 1986) with the whole class to activate and share students’ prior knowledge about the properties of light (K), and to focus attention on what they will be learning about light. Have students delete misconceptions in the K column and add questions to the W column as the study ensues. Students also list facts in the L column. (See *ELA, Strategies*, p. 89.)

➤ **Constructing a Light Box**

Have students paint the interior of a shoebox black. Include the lid. Cut one vertical slit 2 cm long x 1 cm wide in one end. The slit should begin 2 cm from the bottom of the. With tape, affix a flashlight inside the box so that the beam will shine through the slit. (The flashlight may need to be mounted on a base.) The tape will prevent the flashlight from moving when the box is placed on an upright angle. The light box will be used in a number of investigations. Teachers may choose to have each student make a light box or have students work in small groups.

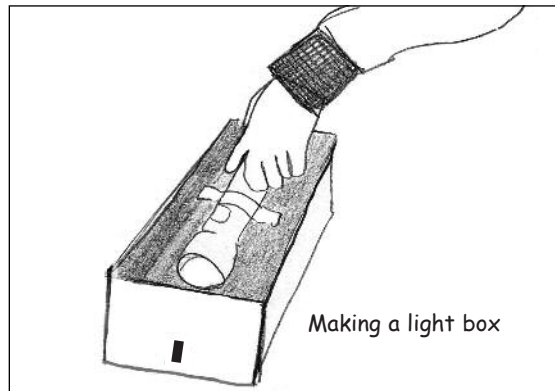

➤ **Investigation 1: Observing How Light Travels**

Provide students/small groups with two squares of heavy black cardboard and one square of white cardboard, each approximately 10 cm x 10 cm square. Each black card should have a hole punched in the centre. Have students use a knitting needle to align the three cards in an upright position with each other and with the light box. (Keep the cards within 45-50 cm of the light box.) The white card should be at the end of the row of cards in order to serve as a screen for the light beam. The cards should be centred so that the two holes on the black cards line up. Have students use plasticine or modelling clay to affix the cards in place to the ground, desk-top, or level surface.

(continued)

TEACHER NOTES

SUGGESTIONS FOR ASSESSMENT

Ensure students include what they recently learned about white light being made up of different colours.

How well the light box works is dependent on the quality of the flashlight and the distance over which the beam is expected to travel. Try to limit distances to 45-50 cm. Commercial light boxes are available and would be beneficial for teacher demonstrations.

PRESCRIBED LEARNING OUTCOMES

Students will...

SUGGESTIONS FOR INSTRUCTION

Darken the room and have students turn on their light boxes and observe how light travels. (Students should see the light travel through the holes of the black cards, producing a circular beam of light on the white screen.) Note: The holes in the cards must be aligned in order for this to work.

Have students predict what will happen to the light beam if they repeat the above investigation after having moved the second black card out of alignment. Have students then move the second black card a few centimetres to the right or left so the holes no longer match up. Have them shine their light boxes in the darkened room. (The circular beam of light will appear on the card that was moved, rather than on the white screen.) Ask the students the following questions:

- Does a light ray bend?
- How do you know?

Extension — Teacher Demonstration

Repeat the previous activities, using a stick of incense, directing the smoke onto the ray of light. This will give students an opportunity to see that the light beam travels in a straight line.

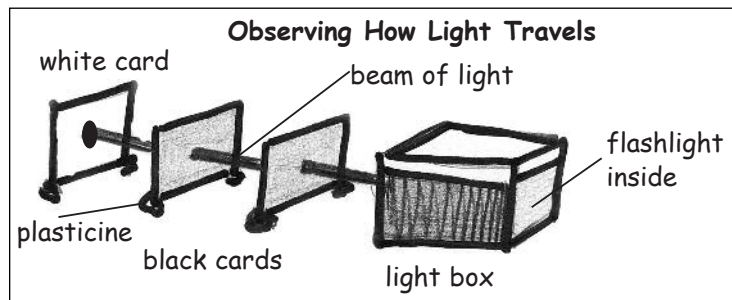

➤ **Investigation 2: Observing Light Travelling through Water**

Have each student/small group place the light box on an elevated stand such as a stack or a box of books. The light box should be arranged so that it is pointing down on an angle, into a large, transparent container of water below, no more than 20-30 cm away. A small aquarium or clear, plastic tub are both suitable. Make the water murky by adding a few drops of milk or some milk powder. Darken the room and have students turn on their light boxes to observe what happens to the beam of light. (The beam will bend when it hits the water.) Ask students:

- Where does the light beam hit the water? (Answers will vary. Beam may enter from the side or top of the container.)
- What happens to the light beam when it hits the water? (It bends. The light does not travel in a straight line.) (continued)

TEACHER NOTES

SUGGESTIONS FOR ASSESSMENT

Observation Checklist: Light Investigations

The student

- asks questions that lead to investigations of light
- makes predictions
- assumes roles and shares group responsibilities
- asks relevant questions
- shares ideas
- uses tools in a manner that ensures personal safety and the safety of others
- records observations in a variety of ways
- draws a conclusion based on evidence gathered through research and observation
- recognizes that experimental results vary slightly when experiments are carried out by different people

PRESCRIBED LEARNING OUTCOMES

Students will...

SUGGESTIONS FOR INSTRUCTION

➤ **Investigation 3: Reflecting Light**

The purpose of this investigation is to observe how light is reflected. Have students elevate their light boxes on stands half a metre away from a light-coloured wall. Have the light boxes shine down, on an angle, onto the floor, where a mirror lies. Have students observe the size and brightness of the patch of reflected light on the wall that occurs as a result of light being shone down onto the reflective surface and bounced onto the wall. For the strongest reflection, boxes should be placed as close as possible to the mirror (10-15 cm) with the mirror placed close to the wall. (The smaller and brighter the patch, the more reflective the surface.) Have students try a variety of materials in place of the mirror, such as crumpled tin foil, flat tin foil, fabric, paper, etc.

Math extension: Have students undertake this activity with a variety of materials. Students should measure the diameter of the patch of light on the wall and describe the quality of the light.

Example:

<u>Materials</u>	<u>Diameter</u>	<u>Quality of Light</u>
mirror	7.5 cm	bright, shiny
crumpled foil	4.5 cm	less bright, spotty
flat foil	7 cm	bright, shiny
metal mesh fabric	3 cm	spotty, dull
paper	1 cm	faint light
black paper	0 cm	no reflection

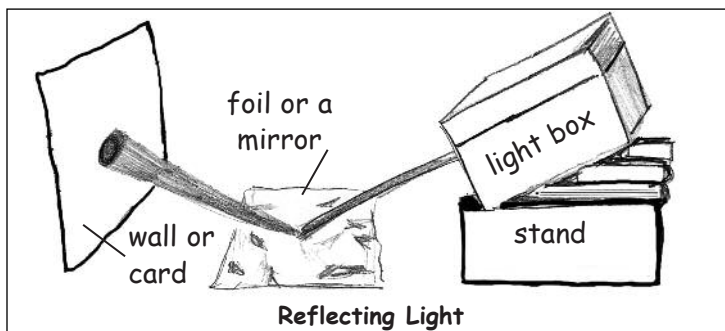

TEACHER NOTES

SUGGESTIONS FOR ASSESSMENT

Learning Log Entry: Light Beams

Student directions: How do materials and objects affect light beams? Make reference to your investigations.

Look for

- intensifies the beam
- bends the beam
- reflects light
- breaks it into different colours

PRESCRIBED LEARNING OUTCOMES

SUGGESTIONS FOR INSTRUCTION

Students will...

4-2-09 Recognize that most objects that produce light also give off heat, and identify objects that produce light but give off little or no heat.
GLO: D4

➤ **Observing Objects in Our Environment**

With students, brainstorm to list objects in our environment that produce light. (Examples: glow-in-the-dark sticks, light bulbs, light sticks, clock radios, glow-in-the-dark stickers, microwaves, calculators, fireflies, etc.)

Questions for Discussion

- Do all lights give off heat?
- Can light be produced without heat?

4-2-10 Classify materials as transparent, translucent, or opaque.
GLO: D3, E1

4-2-11 Evaluate the usefulness of a material for a particular task based on its ability to transmit, reflect, or absorb light.

Examples: usefulness of coloured glass to preserve food and drink by protecting them from light...

GLO: A5, B1, D3

➤ **Demonstration: Transparent, Opaque, and Translucent Materials**

Show students three different drinking glasses — clear, coloured, and styrofoam. Fill the glasses with the same coloured liquid. Ask the following questions:

- What is in each glass?
- How do you know?
- Which one was easiest to tell? Why?

➤ **Investigating Materials**

Have students work in small groups. Have students begin a class collection of different objects or illustrations of objects that are transparent, translucent, or opaque. Have students sort and classify the materials according to the amount of light that shines through. Discuss their classifications. If the terms “transparent,” “opaque,” and “translucent” don’t come up in the discussion, introduce them at this time. Ask students the following questions:

- When might you want to use materials that are transparent? Translucent? Opaque? (Some drinks are put in opaque bottles because they would spoil in the light; windows are transparent because we want light to come in and we want to see outside.)

4-0-4e. Identify problems as they arise, and work with others to find solutions. GLO: C3, C7
4-0-4f. Assume roles, and share responsibilities as group members. (ELA 5.2.2) GLO: C7
4-0-4h. Use tools and apparatus in a manner that ensures personal safety and the safety of others. GLO: C1

TEACHER NOTES

SUGGESTIONS FOR ASSESSMENT

Transparent - materials which allow light to pass through and allow objects on the other side to be seen clearly, e.g., clear glass.

Translucent - materials which allow some light to pass through, but objects behind them cannot be seen clearly, e.g., frosted glass, tissue paper.

Opaque - materials which do not allow light to pass through, e.g., wood, black paper.

Interview: Transparent, Translucent, Opaque

Before the interview gather the following objects: book, piece of frosted glass, aluminum foil, clear plastic bag, clear glass, wax paper, paper bag, and milk carton.

1. Which of the objects in the collection are opaque? How do you know?
 - book
 - aluminum foil
 - paper bag
 - milk carton
 - mentions that no light passes through them
2. Which of the objects are transparent? How do you know?
 - clear plastic bag
 - clear glass
3. Which of the objects are translucent? How do you know?
 - frosted glass
 - wax paper
 - mentions that some light passes through but objects cannot be clearly seen
4. Is it possible to change a transparent object into a translucent object? How?
 - painting or colouring it
 - any reasonable explanation

PRESCRIBED LEARNING OUTCOMES
<i>Students will...</i>
<p>4-2-12 Predict the location, shape, and size of a shadow based on the position of a light source relative to an object. GLO: C2, D4</p>
<p>4-0-3a. Brainstorm, in small groups, one or more methods of finding the answer to a given question, and reach consensus on which method to implement. GLO: C2, C7</p> <p>4-0-3b. Identify, in small groups, variables that have an impact on an investigation. GLO: A1, A2, C2, C7</p> <p>4-0-3c. Create, in small groups, a plan to answer a given question. (ELA 3.1.4; Math SP-V.2.4) GLO: C2</p> <p>4-0-4a. Carry out a plan, and describe the purpose of the steps followed. (Math SP-V.2.4) GLO: C2</p> <p>4-0-4f. Assume roles, and share responsibilities as group members. (ELA 5.2.2) GLO: C7</p> <p>4-0-5b. Estimate and measure mass/weight, length, volume, area, and temperature using standard units. (Math SS-IV.1.4, SS-I.1.4, SS-III.1.4, SS-II.1.4) GLO: C2, C3, C5</p> <p>4-0-6e. Evaluate, with guidance, the methods used to answer a question or solve a problem. GLO: C2, C3</p> <p>4-0-7a. Draw a conclusion based on evidence gathered through research and observation. GLO: A1, A2, C2</p>

SUGGESTIONS FOR INSTRUCTION

➤ **What Do I Know about Shadows?**

Activating Prior Knowledge: Have students complete a Knowledge Chart such as the following

Shadows

Know Now (Draw)	Know Now (List)
Want to know:	

(See the discussion of Prior Knowledge Strategies in *Success for All Learners*, 6.20-6.23.)

➤ **Puppet Shadows: Shadows Investigation**

In small groups, have students identify and carry out a plan to find out what impact the position of the flashlight (light source) has on the location, shape, and size of a shadow from a puppet. Ensure that the groups identify variables that may have an impact on their investigation.

Art Extension: Have students research shadow puppets from different cultures (e.g., Inuit, Chinese, Indonesian, etc.) using a variety of print and electronic resources.

➤ **Reflecting on Shadows**

Have students use their learning logs to summarize what they have found out about shadows. Example:

When the light source is moved closer to the object the shadow gets _____ and its shape looks _____.

When the light source is moved farther from the object the shadow gets _____ and its shape looks _____.

When the light source is moved to the left of the object the shadow moves _____ and its shape looks _____.

When the light source is moved to the right of the object the shadow moves _____ and its shape looks _____.

TEACHER NOTES

SUGGESTIONS FOR ASSESSMENT

Students were first introduced to shadows in Grade 1. They should know that shadows are caused by blocking light.

Have students use Blackline Master 2: Scientific Inquiry Recording Sheet: Grades 3 and 4.

Group Assessment: Shadows Investigation

Answer Yes or No:

During the Shadow Investigation my group

- brainstormed one or more ways to find the answer _____
- identified the variables that have an impact on the experiment _____
- created a plan _____
- identified problems and found a solution _____
- shared roles and responsibilities _____
- estimated and measured the length of the shadows _____
- recorded our results _____
- evaluated our experiment and our results _____
- arrived at a conclusion _____

Next time we will _____
_____.

PRESCRIBED LEARNING OUTCOMES

SUGGESTIONS FOR INSTRUCTION

Students will...

4-2-13 Identify technological developments that extend our ability to see, and recognize their impact on science.
Examples: the telescope allows astronomers to obtain new information...
GLO: A5, B1

4-0-5c. Record observations in a variety of ways. *Examples: point-form notes, sentences, labelled diagrams, charts...* (ELA 2.1.1, 3.3.1, 4.1.1, 4.1.2; Math SP-1.2.4, SP-II.2.4) GLO: C2, C6

4-2-14 Use the design process to construct a device that transmits and reflects light.
Examples: periscope, kaleidoscope...
GLO: B1, C3

4-0-1c. Identify practical problems to solve in the local environment. GLO: C3

4-0-3d. Brainstorm possible solutions to a practical problem, and identify and justify which solution to implement. (ELA 1.2.3) GLO: C3

4-0-3e. Create a written plan to solve a problem or meet a need. Include: identify steps to follow, prepare a labelled diagram. GLO: C3

4-0-3f. Develop criteria to evaluate an object, device, or system based on its function, aesthetics, and other considerations such as materials, and cost. GLO: C3

4-0-4b. Construct an object, device, or system to solve a problem or meet a need. GLO: C3

4-0-4c. Test an object, device, or system with respect to pre-determined criteria. GLO: C3, C5

4-0-4d. Identify and make improvements to an object, device, or system, and explain the rationale for the changes. GLO: C3

4-0-5a. Select and use tools to observe, measure, and construct. *Examples: tuning fork, prism, binoculars, measuring tape...* GLO: C2, C3, C5

4-0-7c. Identify new problems that arise. GLO: C3

4-0-8c. Recognize that designing a solution to a simple problem may have considerations, such as cost, materials, time, and space. GLO: B2, C3

➤ **Centres: The Technology of Light**

Provide students with samples of technological devices and tools, a video about sight and technology, or pictures of objects that extend our ability to see. Examples: binoculars, telescope, optical microscope, eyeglasses, magnifying lens, periscope, telescope, camera, magnifying glass, bug’s eye, etc. After viewing these materials, have students select one object to record what it is used for and how it helps us to do something better or something we weren’t able to do before. Have students share their recordings from the centres. Ask students the following reflection questions to extend their learning:

- How has the microscope helped scientists to fight disease?
- How have binoculars extended our knowledge of animal species?

➤ **Design an Optical Device**

Provide students with a problem that emerges from the narrative literature read by the class. For example, a character in a fictional story may require a device that allows him or her to see around a corner or over a divider wall. Sample evaluation criteria may include the following:

- is hand-held
- uses readily available materials
- is constructed during a given time period
- allows the viewer to see what object the subject is holding when standing around the corner or on the other side of the wall

TEACHER NOTES

SUGGESTIONS FOR ASSESSMENT

Appendix B: Selecting Science-Based Literature provides support to teachers for selecting fictional and non-fictional science literature.

Have students use Blackline Master 4: Design Process Recording Sheets: Grades 3 and 4.

Design Process Checklist

The student

- understands the problem
- brainstorms possible solutions
- creates a written plan
- develops criteria for success
- includes labelled diagram
- constructs a device that reflects or transmits light
- tests the device
- identifies and makes improvements
- identifies new problems that arise
- recognizes that designing a solution may involve cost and materials

PRESCRIBED LEARNING OUTCOMES

SUGGESTIONS FOR INSTRUCTION

Students will...

4-2-15 Describe practices that help ensure protection of eyes and sight.
Examples: direct mirrors away from the eyes when reflecting intense light sources...
 GLO: B3, C1

4-0-2a. Access information using a variety of sources. Examples: school libraries, videos, traditional knowledge, CD-ROMs, Internet... (ELA 3.2.2, 3.2.4, TFS 2.1.1) GLO: C6
4-0-2b. Review information to determine its usefulness to inquiry or research needs. (ELA 3.2.3, 3.3.3) GLO: C6, C8
4-0-7e. Communicate results and conclusions in a variety of ways. Examples: point-form lists, sentences, graphs, labelled diagrams, charts... (ELA 2.3.5, 4.2.5; Math SP-III.1.4, SP-III.2.4; TFS 2.1.4) GLO: C6

➤ **Safety Posters**

Have students conduct research into practices that protect the eyes and eyesight. Students will then design posters that illustrate how to protect eyes and eyesight. Remind students that posters generally consist of slogans and simple eye-catching illustrations. These posters could also be created at the start of the cluster so that they remind students of safe practices during their investigations.

4-2-16 Identify different uses of light at home, at school, and in the community, and explain how the brightness and colour of the light are appropriate for each use.
Examples: vivid neon lights for advertising, blue lights for snow removal vehicles...
 GLO: B1, B3, C1

4-0-4f. Assume roles, and share responsibilities as group members. (ELA 5.2.2) GLO: C7
4-0-4g. Communicate questions, ideas and intentions, and listen effectively to others during classroom-learning experiences. GLO: C6

➤ **Red Means Stop!**

Have students work in partners to identify examples of particular colours that are used to mean specific things (e.g., a stoplight and cars’ brake lights use a red light to mean “stop;” snow removal trucks have blue lights; police cars use flashing red lights).

TEACHER NOTES

SUGGESTIONS FOR ASSESSMENT

A poster indicating the dangers of pen-light lasers should be developed. Serious harm can be done by shining these lasers into someone's eyes.

Scoring Rubric: Safety Posters and Research

Scale	Research	Poster
4	used at least three sources, findings are detailed and clear	neatly and carefully done, depicts eye protection practices in both pictures and words
3	used at least two sources, findings are detailed and clear	neatly and carefully done, depicts eye protection practices in both pictures and words
2	used at least two sources, findings are incomplete or unclear	depicts eye protection practices in both pictures and words
1	used at least one source, findings are incomplete or unclear	depicts eye protection practices in pictures only, carelessly done

Paper and Pencil Task: Red Means Stop

You are in charge of the lighting for your town. What colour and how bright should the lights be for the following objects?

1. street lights?
2. emergency vehicles?
3. snow plows?
4. the signs advertising the town stores?
5. the meeting room in the town hall?
6. classroom lights?

Explain your choices.

Look for

- appropriate colours
- appropriate degrees of brightness
- reasonable explanations

NOTES

Grade 4

Cluster 3: Sound

Overview

In this cluster, students expand their concept of energy by examining sound. This cluster complements the study of another common form of energy – light, which is addressed in *Grade 4, Cluster 2: Light*. Sound is a phenomenon that can be observed, measured, and controlled in various ways. Understanding that sound is caused by vibrations helps students when they explore how sound travels, how the human ear is designed to detect sound, and how certain factors can modify the sound produced. The varying abilities of humans and other animals to detect sound is also examined, which, in turn, leads to discussions about the necessity of protecting one’s sense of hearing. By investigating materials to ascertain whether they transmit, absorb, or reflect sound, students learn how these characteristics influence a material’s function. Students also explore the role of technology in extending one’s ability to produce, transmit, and detect sound.

PRESCRIBED LEARNING OUTCOMES

SUGGESTIONS FOR INSTRUCTION

Students will...

4-3-01 Use appropriate vocabulary related to their investigations of sound.
 Include: energy, sound, vibration, vocal cords, pitch, loudness, sound waves, outer ear, middle ear, inner ear, brain, transmit, absorb, reflect, detect.
 GLO: B1, C6, D4

- Introduce, explain, use, and reinforce vocabulary throughout this cluster.
- **Word Splash**
 Introduce students to their study on sound and activate prior knowledge by using a Word Splash (Saphier and Haley, 1993). Print the vocabulary words randomly on a large wall chart and provide smaller copies for each student. Read the words to the students and have them discuss their meaning.
 Have students write sentences to make predictions about the upcoming unit. Collect and save all predictions and review them at the end of the study. Students can then identify what they learned. (See *Success for All Learners*, 6.29.)
- **I Wonder Chart**
 Post a large sheet of chart paper entitled “I Wonder About Sound.” Invite students to record broad questions about this topic throughout this study. Ensure questions are answered throughout the study. (See *ELA, Grade 4*, pp. 166 and 168.)

4-3-02 Recognize that sound is a form of energy.
 GLO: D4, E4

4-3-03 Recognize that energy makes things happen and can be found all around us.
 GLO: D4, E4

- **How Do We Use Energy?**
 Have students use Think-Pair-Share (McTighe and Lyman, 1992) to think about and share ideas of the different ways we use energy. (Note: Think-Pair Share is discussed in *ELA, Strategies*, p. 15.)
- **Observing the Environment: Evidence of Energy At Work**
 Take a class tour of the school and its surroundings to identify evidence of energy. Examples: fans, lights, bells, whistles, echoes, machines running, airplanes, cars, computers, calculators, etc. Have students record their observations in learning logs.

4-0-4g. Communicate questions, ideas and intentions, and listen effectively to others during classroom-learning experiences. GLO: C6

4-0-7d. Construct meaning in different contexts by connecting new experiences and information to prior experiences and knowledge. (ELA 1.2.1, 2.1.2) GLO: A2, C6

Producing Sound

Part 1) Provide a series of pictures of objects and living things that produce sound for a picture sort. Have the students work in small groups to sort the visual images according to the source of the sounds. Have students share their observations with the class.

Part 2) Have students work with a partner to select one picture from the picture sort. Students should describe how sound energy is being used. Example: A singer uses sound energy to create music. Students can share their findings in a Sharing Circle. (See *ELA, Grade 4*, p. 212.)

TEACHER NOTES

SUGGESTIONS FOR ASSESSMENT

In later years students will define energy as the ability to do work (See Teacher Notes on Energy in Cluster 2: Light p. 4.21.) Energy makes things happen and includes movement, heat, electricity, chemical reactions (food), magnetic attraction, gravity, nuclear reaction, sound, and light. Energy can be stored and used at later times (potential energy). Sound is a form of energy because sound vibrations pass through solids, liquids, and gases, causing the molecules to vibrate sympathetically.

Outcomes 4-3-02 and 4-3-03 are very similar to outcomes 4-02-02 and 4-2-03 in Grade 4, Cluster 2: Light. If the class has already studied that cluster, a quick review with a “sound focus” should be sufficient.

Science Journal Entry: Energy

Have students answer the following questions:

1. What is energy?
2. Where do you find energy? Give six examples.
3. Is sound a form of energy? Explain.

Look for

- makes things happen
- found all around us
- six examples given
- sound is a source of energy
- makes reference to Investigating Sound Vibrations

PRESCRIBED LEARNING OUTCOMES

SUGGESTIONS FOR INSTRUCTION

Students will...

4-3-04 Identify and classify various sounds using student-generated criteria.
GLO: C2, D4

4-0-6c. Choose and identify relevant attributes for use in a classification system, and create a chart or diagram that shows the method of classifying. (Math PR-II.2.4) GLO: C2, C3, C5

4-0-6d. Sort and classify according to an established classification system. (Math PR-II.2.4) GLO: C2, C3

➤ **Sorting Sounds**

Brainstorm to create a list of familiar sounds. In small groups, have students sort the sounds according to their own categories. Have students share their categories. Encourage students to review their categories and make changes. Examples of categories can include: pitch (high/low); volume (loudness); and purpose of the sound (communication, warning, entertainment). Include terms on a Word Splash chart (Saphier and Haley, 1993). (Note: Word Splash is discussed in *Success for All Learners*, 6.28.)

4-3-05 Recognize that sounds are caused by vibrations.
Include: the human voice relies on the vibrations of vocal cords.
GLO: D3, D4

➤ **Investigating Sound Vibrations**

Have students work in small groups to investigate how sound vibrations are a source of energy. Have the students stretch plastic wrap over a large can and place grains of salt, sugar, or sand on top of the plastic wrap. Have one student in each group strike a tuning fork and bring it near the plastic wrap (not touching). The grains will begin to jump in response to the sound vibrations. Instruct students to move the tuning fork farther away from the plastic wrap and observe the effect. Discuss the results, focussing on the following questions:

- What made the grains jump?
- What effect did moving the tuning fork closer to or farther away from the plastic wrap have on the grains?
- What did you learn about sound?

4-0-4h. Use tools and apparatus in a manner that ensures personal safety and the safety of others. GLO: C1

4-0-5a. Select and use tools to observe, measure, and construct. *Examples: tuning fork, prism, binoculars, measuring tape...* GLO: C2, C3, C5

4-0-7e. Communicate results and conclusions in a variety of ways. *Examples: point-form lists, sentences, graphs, labelled diagrams, charts...* (ELA 2.3.5, 4.2.5; Math SP-III.1.4, SP-III.2.4; TFS 2.1.4) GLO: C6

4-0-8b. Recognize that scientists must support their explanations using evidence and scientific knowledge. GLO: A1, A2, C2

➤ **Sound Centres**

Set up a series of Sound Centres to explore sound vibrations. Examples of centre explorations might include the following:

- plucking an elastic that has been stretched across a tin or a box
- blowing across the top of an empty pop bottle
- rubbing a moistened finger around the rim of a wine glass
- striking a tuning fork and placing it beside the ear
- extending a ruler over the edge of a desk and gently plucking it
- wrapping a comb with wax paper and buzzing your lips on it (change the paper after each child for sanitary reasons)

(continued)

TEACHER NOTES

SUGGESTIONS FOR ASSESSMENT

Empty box for teacher notes.

Paper and Pencil Task: Sound Vibrations

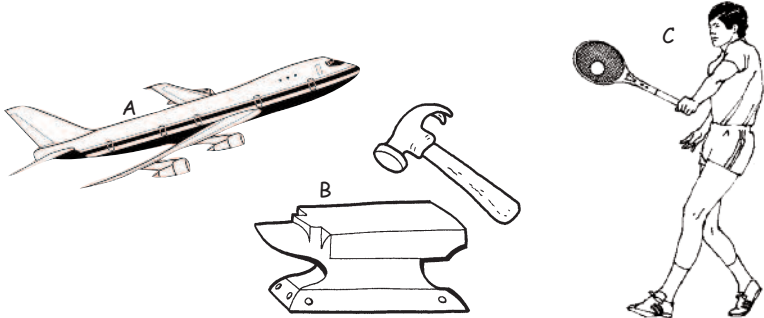

For each picture, tell what sound you would hear and what makes the sound.

- A _____
- B _____
- C _____

PRESCRIBED LEARNING OUTCOMES
<i>Students will...</i>

SUGGESTIONS FOR INSTRUCTION

As students explore each Sound Centre, have them complete the following observation charts:

Centre No. _____

What I saw: _____
 _____.

What I heard: _____
 _____.

What I felt: _____
 _____.

One question that I have about this sound device is _____
 _____?

➤ **How Does the Human Voice Work?**

Provide students with a simple diagram of the human throat and mouth. Challenge students in small groups to explain how humans produce sound. Their answers should be based on what they have learned.

4-3-06 Use the design process to create a musical instrument.
 GLO: C3, C5, D4, E2

➤ **Building a Musical Instrument**

Activate students' prior knowledge and stimulate their thinking by providing a variety of musical instruments whose sounds are produced in different ways. Substitute pictures if instruments are not readily available. Encourage students to explore the instruments to determine how each one produces a sound. Sample criteria for evaluation may include the following:

- 4-0-1c.** Identify practical problems to solve in the local environment. GLO: C3
- 4-0-3d.** Brainstorm possible solutions to a practical problem, and identify and justify which solution to implement. (ELA 1.2.3) GLO: C3
- 4-0-3e.** Create a written plan to solve a problem or meet a need. Include: identify steps to follow, prepare a labelled diagram. GLO: C3
- 4-0-3f.** Develop criteria to evaluate an object, device, or system based on its function, aesthetics, and other considerations such as materials, and cost. GLO: C3
- 4-0-4b.** Construct an object, device, or system to solve a problem or meet a need. GLO: C3
- 4-0-4c.** Test an object, device, or system with respect to pre-determined criteria. GLO: C3, C5
- 4-0-4d.** Identify and make improvements to an object, device, or system, and explain the rationale for the changes. GLO: C3
- 4-0-7c.** Identify new problems that arise. GLO: C3
- 4-0-8c.** Recognize that designing a solution to a simple problem may have considerations, such as cost, materials, time, and space. GLO: B2, C3

- produces three different sounds
- is hand-held
- is sturdy
- uses everyday materials
- includes a labelled design plan
- has a way to modify pitch/loudness
- is visually appealing

Have the students follow the design process to create their own instrument.

TEACHER NOTES

SUGGESTIONS FOR ASSESSMENT

Have students use Blackline Master 4: Design Process Recording Sheet: Grades 3 and 4.

Design Process Checklist

The student

- understands the problem
- brainstorms possible solutions
- creates a written plan
- develops criteria for success
- includes labelled diagram
- constructs the musical instrument
- tests the device
- identifies and makes improvements
- identifies new problems that arise
- recognizes that designing a solution may involve cost and materials

Self-Assessment of the Design Process

Musical Instrument Design Project

I chose to make a _____.

1. One problem I had was _____.
2. One thing I did well was _____.
3. If I did this project again I would _____.
4. I would still like to learn more about _____.
5. I think my design _____.

PRESCRIBED LEARNING OUTCOMES

SUGGESTIONS FOR INSTRUCTION

Students will...

4-3-07 Demonstrate how the pitch and loudness of sounds can be modified.
Examples: differences in sound when plucking a loose rubber band vs. a stretched rubber band...
GLO: C2, D3, D4, E3

4-0-4h. Use tools and apparatus in a manner that ensures personal safety and the safety of others. GLO: C1

➤ **Investigating Pitch and Loudness**

Set up stations or centres to explore pitch and loudness or have students re-visit the existing Sound Centres with this new purpose. (See 4-3-05.) Some centre suggestions include the following:

- Have the students make a pan flute with straws by cutting the straws into different lengths. Students arrange straws from longest to shortest and tape these together. Have them: pinch one end of each straw together approximately two cm from the end, cut the corners so they make a “V” shape, and separate the ends.
- Have students examine a guitar, banjo, or ukulele.
- Have students make a drum using a large container and a balloon and explore to see what happens when the balloon is stretched tighter across the opening.
- Have students place a ruler over the edge of a desk and pluck the ruler while varying the length of the overhanging end.
- Use several pop bottles. Put varying amounts of water in the bottles. Have students tap the bottles and blow across the openings.
- Use several various-sized elastics stretched around a metal pan. Have students pluck the elastics to explore the various sounds.

At each centre, have students complete an investigation sheet such as

I can change the pitch by _____
_____.

I can change the volume by _____
_____.

I can modify my instrument to change pitch by _____
_____.

4-3-08 Observe and describe properties of sound.
Include: travels in waves in all directions.
GLO: C2, D4

➤ **Find the Sound Game**

Have one student stand in the middle of the room with his or her eyes shut. Have the other students move around the room and in turn, make sounds. The person in the middle identifies where the sound is coming from by pointing in that direction.

Variation: The person in the middle makes the noise and the other students try to move around the room to a location where they cannot hear the sound. Use the following questions for discussion.

- Why could the person in the middle identify the location of the sound?
- Was there any location in the room in which you could not hear the sound? Why?

(continued)

TEACHER NOTES

Pitch is defined as the relative height of a sound (high, low, etc.). The pitch is dependent on the number of vibrations per second. Objects that are thin and/or taut will vibrate faster, therefore creating a higher sound. Objects that are thick and/or loose will vibrate more slowly, thus creating a lower sound. The length of the object also affects the pitch. The shorter the object, the higher the pitch.

SUGGESTIONS FOR ASSESSMENT

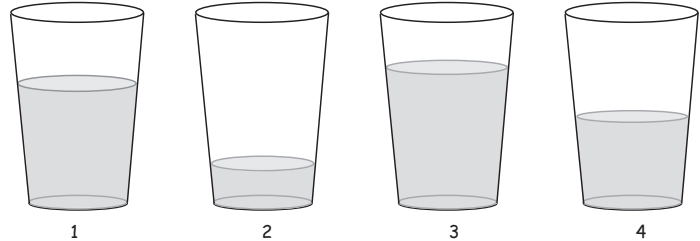
Multiple Choice: Pitch and Loudness

- If you tapped each glass with a spoon, which one would make the lowest-pitched sound? (C)
 - 1
 - 2
 - 3
 - 4
- When constructing her musical instrument, Anna-Ruth wanted to make a higher pitched sound on her banjo strings. What should she do? (C)
 - use thicker strings
 - lengthen the strings
 - tighten the strings
 - pluck the strings harder
- How can you decrease the pitch of a sound? (A)
 - lengthen the object
 - shorten the object
 - leave the object the same
 - tighten the object
- Paul has two elastics. The first elastic is thin and the other is thick. He plucks the thin elastic. What will be different when he plucks the thick elastic? (B)
 - it will vibrate faster
 - it will vibrate slower
 - it will vibrate at the same rate
 - it will make a higher sound

PRESCRIBED LEARNING OUTCOMES

SUGGESTIONS FOR INSTRUCTION

Students will...

➤ **Investigating Properties of Sound**

Have students work in small groups to observe the properties of sound. Give each group a tuning fork and a pan of water. Have students strike the tuning fork and then touch the prongs to the surface of the water. Use the following discussion questions:

- What happened to the water?
- What does it show about sound?
- How is the way that sound travels different from the way that light travels? (Ask this only if students have completed Cluster 2 on light.)

4-3-09 Describe how the human ear is designed to detect sound vibrations.
 Include: sound is transmitted from the outer ear to the middle ear and the inner ear, which relays messages to the brain.
 GLO: D1, D4

➤ **Inquiry: How Humans Detect and Process Sound**

Follow the procedure for using the Inquiry Chart (Hoffman, 1992) to research and present information about how humans detect and process sound. (Note: The Inquiry Chart is discussed in *ELA, Strategies*, pp. 83 - 88.) Ensure the resources are at a level appropriate for students. You may want to implement the following research strategies.

Skimming

Model how to determine if a science reference will provide needed information by rapidly glancing through a text. (See *ELA, Grade 4*, p. 236.)

Scanning

Model and provide guided practice to teach students how to find target words, specific facts, captions, illustrations, and charts. The Internet is a valuable place to model and teach scanning. (See *ELA, Grade 4*, p. 238.)

Interviewing Experts

Invite a doctor or audiologist to discuss information related to the ear. Students can take notes and ask open-ended questions. (See *ELA, Grade 4*, p. 196; *Success for All Learners*, Ch.7.)

Slim Jims

Teach students how to use Slim Jims to record key information for their inquiry. (See *ELA, Strategies*, p.116.)

4-0-2a. Access information using a variety of sources. *Examples: school libraries, videos, traditional knowledge, CD-ROMs, Internet...* (ELA 3.2.2, 3.2.4, TFS 2.1.1) GLO: C6
4-0-2b. Review information to determine its usefulness to inquiry or research needs. (ELA 3.2.3, 3.3.3) GLO: C6, C8
4-0-4e. Identify problems as they arise, and work with others to find solutions. GLO: C3, C7
4-0-5c. Record observations in a variety of ways. *Examples: point-form notes, sentences, labelled diagrams, charts...* (ELA 2.1.1, 3.3.1, 4.1.1, 4.1.2; Math SP-1.2.4, SP-II.2.4) GLO: C2, C6

TEACHER NOTES

SUGGESTIONS FOR ASSESSMENT

Science Journal Entry: Properties of Sound

Three things that I know about sound are:

1. _____.
2. _____.
3. _____.

Look for

- travels in waves
- travels in all directions
- caused by vibrations

There are three main parts to the ear. The **outer ear**, **middle ear**, and **inner ear**. Sound enters the outer ear and is collected in the **pinna** (the fleshy part of the outer ear that is visible) and is funneled into the auditory canal. It passes to the middle ear through the **auditory canal** to the **ear drum**. As the ear drum vibrates, it moves the **malleus** (hammer) which in turn moves the **incus** (anvil) which pushes the **stapes** (stirrup) against another membrane in the **cochlea**. The cochlea, part of the inner ear, is a liquid-filled, shell-like coil containing numerous **nerve endings**. As the membrane is pushed it pushes the internal liquid across the nerve endings. The nerve endings respond by sending a message through the **auditory nerve** to the brain. The brain analyzes the responses as sound.

PRESCRIBED LEARNING OUTCOMES	SUGGESTIONS FOR INSTRUCTION
<p><i>Students will...</i></p>	
<p>4-3-10 Recognize that there is a range of sounds that humans can and cannot hear. GLO: D1</p>	<p>➤ Can You Hear It? Have the students brainstorm to identify examples of sounds that animals can hear but that humans cannot. Have students try to describe what types of sounds these are. Example: dog whistles emit a high-pitched sound that humans can't hear. Provide students with a decibel scale (unit used to measure sound) and relate this information to audible sounds for humans and other animals.</p>
<p>4-0-7d. Construct meaning in different contexts by connecting new experiences and information to prior experiences and knowledge. (ELA 1.2.1, 2.1.2) GLO: A2, C6</p>	
<p>4-3-11 Describe practices that help ensure protection of the ears and hearing. <i>Examples: use of ear plugs in situations involving excessive noise...</i> GLO: B3, C1</p> <p>4-3-12 Describe harmful effects of high or sustained sound levels and identify potential sound hazards at home or in the community. <i>Examples: leaf-blowing machines, snowblower, stereo, drone of machinery...</i> GLO: B1, B3, C1</p>	<p>➤ Protecting Hearing Have the students list things or situations that may harm the ears and hearing. Discuss ways in which the ears and hearing can be protected in these situations. Identify safety rules for the ears (e.g., avoid putting any object in the ear; avoid loud sounds; if you need to be near loud sounds, use protective equipment, etc.). Advertise and Present: Have students create and advertise an apparatus that can reduce harmful sounds entering their ears, e.g., styrofoam cup head phones, a noise-limiting box to go around a radio, etc. Have the students present their “product” to the class through a commercial, newspaper report, etc.</p> <p>➤ Ask an Expert Invite an audiologist or local doctor to talk about hearing and the harmful effects of certain sounds.</p>
<p>4-0-4f. Assume roles, and share responsibilities as group members. (ELA 5.2.2) GLO: C7</p> <p>4-0-4g. Communicate questions, ideas and intentions, and listen effectively to others during classroom-learning experiences. GLO: C6</p> <p>4-0-7e. Communicate results and conclusions in a variety of ways. <i>Examples: point-form lists, sentences, graphs, labelled diagrams, charts...</i> (ELA 2.3.5, 4.2.5; Math SP-III.1.4, SP-III.2.4; TFS 2.1.4) GLO: C6</p>	<p>➤ Identifying Sound Hazards in the Environment Take a walk in the school community. Have the students identify potential sound hazards. Use the following questions to focus student observations:</p> <ul style="list-style-type: none"> • What potential sound hazards can you find? • What form of protection (if any) was used? • How can we reduce these potential sound hazards?
	<p>➤ Sound Hazards at Home Extend the above activity to the home. Have students list potential sound hazards found in their homes. Once the list is made, have the students and their family devise a plan showing how to eliminate or reduce these hazards.</p>

TEACHER NOTES

SUGGESTIONS FOR ASSESSMENT

**Performance Task: Advertise and Present
Scoring Rubric**

Scale	Protective Apparatus	Presentation
4	creative and effective in reducing noise	detailed, complete, and clearly presented
3	effective in reducing noise	complete and clearly presented
2	complete but ineffective in reducing noise	complete but unclear or lacks sufficient detail
1	incomplete and ineffective in reducing noise	incomplete or unclear

PRESCRIBED LEARNING OUTCOMES
<i>Students will...</i>
<p>4-3-13 Investigate to compare how vibrations travel differently through solids, liquids, and gases. GLO: C2, D3, E1</p>
<p>4-0-1b. Make and justify predictions based on observed patterns, collected data, or data provided from other sources. <i>Examples: graph, chart...</i> (ELA 1.1.1, 1.2.1; Math PR-III.1.4) GLO: A1, C2</p> <p>4-0-4a. Carry out a plan, and describe the purpose of the steps followed. (Math SP-V.2.4) GLO: C2</p> <p>4-0-7a. Draw a conclusion based on evidence gathered through research and observation. GLO: A1, A2, C2</p> <p>4-0-7b. Identify new questions that arise from what was learned. (ELA 3.3.4) GLO: A1, C2, C3</p> <p>4-0-9b. Demonstrate confidence in their ability to do science. GLO: C5</p>

SUGGESTIONS FOR INSTRUCTION

➤ **Investigating Sound Transmission**

Have students fill three plastic bags: one with air, one with water, and one with a solid, such as plasticine or a book. Have students take turns holding each bag against their ears while a partner scratches on or lightly taps the bag. Have the partners compare the sounds.

Before carrying out this investigation have students predict what they think will happen. Students should write their prediction in their learning logs, and during the investigation they should record the data in a chart like the following.

	Observations
Bag 1 Air	I heard...
Bag 2 Liquid	I heard...
Bag 3 Solid	I heard...

Have the students scratch the top of their desk or table with their fingernails and then listen to the sound. Have them place their ear on the desk or table and scratch again to compare the sounds. Students record the results in their learning logs. Ask students the following questions:

- Was there a difference in the sounds using the bags?
- Was there a difference in the sounds using the desk or table?
- What can you conclude from these investigations?

➤ **Family Science**

For homework, have the students try the “scratch test” in either a pool or a bathtub. First, keeping their head out of the water, students will scratch the side of the pool or tub. They repeat this with their head under the water to compare the sounds heard.

(Caution: Ensure you discuss safety with your students before they attempt this activity.)

TEACHER NOTES

SUGGESTIONS FOR ASSESSMENT

Paper and Pencil Task: Sound Transmission

1. How do you know that sound travels through the following states of matter:
Gas? _____
Liquid? _____
Solid? _____

2. List the following in order from the best material for sound to travel through to the worst: juice, cement wall, carbon dioxide gas. Explain your answer.

PRESCRIBED LEARNING OUTCOMES	SUGGESTIONS FOR INSTRUCTION
<p><i>Students will...</i></p>	
<p>4-3-14 Explore to determine the ability of materials to transmit or absorb sound. GLO: C2, D3, E1</p>	<p>➤ Investigate Materials that Absorb or Transmit Have students work in small groups to develop a plan to determine whether materials absorb or transmit sound, using a loud ticking clock or other sound-making device. They must make predictions and identify variables that will have an impact on their investigations. Students will test a variety of materials to see whether they absorb or transmit sound. Students must evaluate their procedures following their investigations. Examples of procedures may include: covering the clock with a cloth, touching pieces of wood and metal to the clock, etc.</p>
<p>4-0-3a. Brainstorm, in small groups, one or more methods of finding the answer to a given question, and reach consensus on which method to implement. GLO: C2, C7 4-0-3b. Identify, in small groups, variables that have an impact on an investigation. GLO: A1, A2, C2, C7 4-0-3c. Create, in small groups, a plan to answer a given question. (ELA 3.1.4; Math SP-V.2.4) GLO: C2 4-0-4a. Carry out a plan, and describe the purpose of the steps followed. (Math SP-V.2.4) GLO: C2 4-0-4e. Identify problems as they arise, and work with others to find solutions. GLO: C3, C7 4-0-4h. Use tools and apparatus in a manner that ensures personal safety and the safety of others. GLO: C1 4-0-5a. Select and use tools to observe, measure, and construct. <i>Examples: tuning fork, prism, binoculars, measuring tape...</i> GLO: C2, C3, C5 4-0-6e. Evaluate, with guidance, the methods used to answer a question or solve a problem. GLO: C2, C3 4-0-7a. Draw a conclusion based on evidence gathered through research and observation. GLO: A1, A2, C2 4-0-8a. Recognize that experimental results may vary slightly when carried out by different persons, or at different times or places; but that if the results of repeated experiments are very different, something must be wrong with the design of the experiment. GLO: A1, A2, C2</p>	
<p>4-3-15 Describe how materials that absorb or reflect sound are used in different situations. <i>Examples: concrete sound barriers are placed beside highways to absorb sound...</i> GLO: B1, C1, D3</p>	<p>➤ Observing the Environment — How Do They Do That? Set the context by asking students the following questions:</p> <ul style="list-style-type: none"> • What do you want to happen to the sound in a concert hall? • What types of materials would you use in building a concert hall? • People do not like to build homes beside busy highways/streets due to the noise. What can be done to reduce this noise?
<p>4-0-1a. Ask questions that lead to investigations of living things, objects, and events in the local environment. (ELA 1.2.4, 3.1.2) GLO: A1, C2, C5 4-0-5c. Record observations in a variety of ways. <i>Examples: point-form notes, sentences, labelled diagrams, charts...</i> (ELA 2.1.1, 3.3.1, 4.1.1, 4.1.2; Math SP-1.2.4, SP-II.2.4) GLO: C2, C6</p>	<p>Plan a field trip to a concert hall, multiplex theatre, or other location where students can see how these structures are designed to absorb, reflect, or transmit sound. Students make notes of their observations and ask pertinent questions. Students may access similar information through the Internet.</p>

TEACHER NOTES

Students must begin to recognize that factors or **variables** must be kept the same in order to be able to draw reasonable conclusions. Students should be encouraged to focus on one aspect or variable at a time, and try to control all the other variables. This way, any differences observed can be more accurately attributed to the variable being studied.

Have students use Blackline Master 2: Scientific Inquiry Recording Sheet: Grades 3 and 4.

SUGGESTIONS FOR ASSESSMENT

Observation Checklist: Investigating Materials that Absorb or Transmit

The student

- brainstorms one or more methods of finding the answer
- creates a plan
- carries out a plan
- describes the purpose of the steps followed
- identifies problems as they arise, and works with others to find solutions
- uses tools and apparatus safely
- selects and uses tools to observe, measure, and construct
- evaluates, with guidance, the methods used to answer a questions or solve a problem
- draws a conclusion based on evidence gathered through research and observation
- recognizes that experimental results may vary

PRESCRIBED LEARNING OUTCOMES

SUGGESTIONS FOR INSTRUCTION

Students will...

4-3-16 Describe devices that extend our ability to produce, transmit, and detect sound.
Examples: amplifier, hearing aids, megaphone, ear trumpet...
GLO: B1

4-3-17 Investigate to identify inventions related to sound, and describe their impacts on society.
Examples: radio, telephone, microphone...
GLO: A4, B1, B2

4-0-2a. Access information using a variety of sources. *Examples: school libraries, videos, traditional knowledge, CD-ROMs, Internet...* (ELA 3.2.2, 3.2.4, TFS 2.1.1) GLO: C6

4-0-2b. Review information to determine its usefulness to inquiry or research needs. (ELA 3.2.3, 3.3.3) GLO: C6, C8

4-0-7e. Communicate results and conclusions in a variety of ways. *Examples: point-form lists, sentences, graphs, labelled diagrams, charts...* (ELA 2.3.5, 4.2.5; Math SP-III.1.4, SP-III.2.4; TFS 2.1.4) GLO: C6

4-3-18 Describe the role of sound in different jobs and hobbies.
Examples: physician listens to a patient’s heartbeat during a check-up, birders identify birds by their calls...
GLO: B4

➤ **Extending Our Abilities: Research Projects**
Have students list practical applications of the principles of sound by focussing on devices that extend the ability to produce, transmit, and detect sound. Have students select and research one hearing device. Students may work with a partner. Have the students research other sound devices using books, the Internet, or CD-ROMs. Have them find out who invented the device, what the device looks like, what modifications have been made over time, how it works, and the impact it has made.

➤ **Great Inventions**
Read or tell the story of Alexander Graham Bell. Have the students discuss the impact that his invention has had on society over time. Have students imagine what it would be like not to have telephones. (Note: Students who do not have phones in their homes still have access to phones in other locations such as the school.) Ask the following questions:

- What are the advantages of not having access to a telephone?
- What are the disadvantages?

Have students select their own invention to research. In their reports, students should describe the invention, the inventor, and the impact of the invention on society. Reports should be presented to class. Note: Encourage students to research Canadian inventions wherever possible.

➤ **Interviewing Experts**
With students, develop a series of questions they can ask parents and community members about the role of sound in their jobs or hobbies. Develop a list of people to be interviewed by students. Interviews may be done in person or using the telephone or Internet. Have students present their interview information orally during a Sharing Circle (*Success for All Learners*, 7.5).

Have students record brief statements about how individuals use sounds in particular situations on fact cards. Fact cards can then be posted to create a “Uses of Sound” fact frieze.

TEACHER NOTES

SUGGESTIONS FOR ASSESSMENT

[Empty box for teacher notes]

Peer Assessment: Great Inventions

This presenter (name) _____,

spoke clearly (yes/no) _____.

He/she made the presentation interesting by

using pictures, drawings, etc.

using actions

other _____

_____.

Included enough information _____.

Suggestions/Comments _____

_____.

[Empty box for teacher notes]

Self-Reflection for Sound Cluster

Three things that I learned during the study of sound are

1. _____.

2. _____.

3. _____.

I liked _____.

I didn't like _____.

I still would like to learn more about _____

_____.

NOTES

Grade 4

Cluster 4: Rocks, Minerals, and Erosion

Overview

The study of rocks and minerals introduces students to geology. By examining various rocks and minerals found in the Earth's crust, students learn about their characteristics and properties. These characteristics and properties determine how these rocks and minerals are used by humans. Students discover the role rocks play in forming soil (see *Grade 3, Cluster 4: Soils in the Environment*) and in providing us with information about Earth's history. Students advance their understanding of the changing landscape by becoming aware of how wind, water, and ice continue to reshape it through erosion. This leads students to explore ways in which humans can adapt to and prevent or make changes in the landscape.

PRESCRIBED LEARNING OUTCOMES

SUGGESTIONS FOR INSTRUCTION

Students will...

4-4-01 Use appropriate vocabulary related to their investigations of rocks, minerals, and erosion.
 Include: rock, mineral, characteristic, property, scratch test, streak test, igneous, sedimentary, metamorphic, fossil, organism, extinct, soil formation, erosion, natural phenomena.
 GLO: C6, D5

- Introduce, explain, use, and reinforce vocabulary throughout this cluster.
- **Word Splash**
 Begin the study of rocks and minerals with a Word Splash. Include the words rock, mineral, characteristic, property, scratch test, streak test, igneous, sedimentary, and metamorphic. (See *Success for All Learners*, 6.28 for a procedural outline.)
- **Word Wall**
 Begin to develop a Science Word Wall by recording the terms from the Word Splash on a large wall chart. (See *ELA, Strategies*, p. 19.)

4-4-02 Classify rocks and minerals according to student-generated criteria.
 GLO: C2, D3, D5

- **Observing Rocks**
 Ask students to bring in a variety of rocks or provide students with kits. Have students work in pairs to describe, in as much detail as possible, the rocks in their collection. Use of tools such as magnifying glasses, scales, and measuring tapes, etc., should be encouraged to enhance observations. Once the observations are completed, have students classify the rocks and re-classify them several times, recording the groupings and criteria used each time. Have each pair share their classification categories with the class. The following charts can be used to record observations and classifications:

4-0-5a. Select and use tools to observe, measure, and construct. *Examples: tuning fork, prism, binoculars, measuring tape...* GLO: C2, C3, C5

4-0-6a. Construct bar graphs and pictographs using many to one correspondence, and interpret these as well as graphs from other sources. (Math SP-III.2.4) GLO: C2, C6

4-0-6c. Choose and identify relevant attributes for use in a classification system, and create a chart or diagram that shows the method of classifying. (Math PR-II.2.4) GLO: C2, C3, C5

Rock Observations

Rock #1 _____
 Rock #2 _____
 Rock #2 _____

Classifying Rocks (sample chart)

Classification #1:
 classified according to: shape
Rounded Sharp Edges Mixture of Round and Sharp
 rock #1 rock #2 rock #4
 rock #3 rock #5

Classification #2:
 classified according to: texture
Rough Smooth
 rock #1 rock #2
 rock #3 rock #4 rock #5

TEACHER NOTES

SUGGESTIONS FOR ASSESSMENT

Overall Cluster Note: Teachers should be aware that the Earth (including rocks) is considered to be a living, spiritual force in traditional Aboriginal cultures. Additionally, rock plays an important role in many spiritual processes.

Caution: Encourage students to be cautious if collecting their own rocks. Trying to break apart a rock can send fragments flying into the air. Eye protection should be worn.

The label **rock** is often used to refer to rock or mineral substances. At this stage in the cluster, no attempt should be made to differentiate between the two.

Throughout Grades 1 to 3, students have developed their ability to observe using all of their senses and to identify and describe characteristics and properties of objects and materials. Students should be encouraged to use all of these skills in describing the rocks in many ways. Terms like **colour, texture, shape, size, smell, and lustre** (shiny or dullness) should appear in their discussions. Other characteristics such as mass/weight and magnetic attraction may also emerge.

Creative classification allows students to examine several rocks and minerals (without worrying about distinctions among them). Students can describe them, identify likenesses and differences, and develop classifications. Formal identification should not take place at this time.

Self-Assessment: Observing Rocks

1. I used the following senses to observe the rocks:

- sight
- hearing
- touch
- smell

2. I used the following tools to observe the rocks:

- ruler
- magnifying glass
- other _____

3. I identified the following properties:

- colour
- texture
- shape
- size
- other _____

4. My observations skills are _____
_____.

PRESCRIBED LEARNING OUTCOMES
<i>Students will...</i>
<p>4-4-03 Test to determine characteristics of rocks and properties of minerals, and classify accordingly.</p> <p>Include: scratch test for hardness, streak test for colour.</p> <p>GLO: A1, C2, D3, D5</p> <p>4-4-04 Differentiate between minerals and rocks.</p> <p>Include: minerals are composed of the same substance throughout, rocks are composed of two or more minerals...</p> <p>GLO: D5</p>
<p>4-0-4a. Carry out a plan, and describe the purpose of the steps followed. (Math SP-V.2.4) GLO: C2</p> <p>4-0-5c. Record observations in a variety of ways. <i>Examples: point-form notes, sentences, labelled diagrams, charts...</i> (ELA 2.1.1, 3.3.1, 4.1.1, 4.1.2; Math SP-1.2.4, SP-II.2.4) GLO: C2, C6</p> <p>4-0-7b. Identify new questions that arise from what was learned. (ELA 3.3.4) GLO: A1, C2, C3</p> <p>4-0-9b. Demonstrate confidence in their ability to do science. GLO: C5</p>

SUGGESTIONS FOR INSTRUCTION

➤ **Rock or Mineral?**

Tell students that the “rocks” they have been classifying are actually mixtures of rocks and minerals. Provide each pair of students with a few samples of both rocks and minerals. Have students use a chart to describe and compare the characteristics of each. Have each pair share their findings. As a class, discuss the one characteristic that seemed to distinguish rocks from minerals. (The samples should be carefully chosen to clearly show rocks as mixtures of things and minerals as one substance throughout.) Have students write class definitions for rocks and minerals in their science journals. Students should also draw what each sample would look like if it was cut in half. (Have students visualize a plain muffin versus a blueberry and walnut muffin.)

➤ **Testing Minerals**

Provide students with informational text in which the properties of minerals are discussed (e.g., made from crystals, crystals can be identified by colour, hardness, crystal formation, etc.). Have students complete hardness tests on their sample minerals, as well as on minerals from their own collections. (They will first have to determine which samples from their own collections are minerals.) For the tests, students will attempt to scratch the mineral with their fingernail, a penny, and a steel nail, and record their results in a chart such as the following:

Mineral Hardness Test

Mineral	#1	#2	#3
fingernail scratches:	_____	_____	_____
penny scratches:	_____	_____	_____
steel nail scratches:	_____	_____	_____

Have students use Moh’s Hardness Scale to determine each mineral’s approximate hardness based on the results. Fingernails have a hardness of about 2.5, a penny has a hardness of 3, and steel has a hardness of about 5.5. Have students place their minerals in order from softest to hardest. After the mineral tests, have students reflect on the following questions in their science journals:

- How would you go about identifying an unknown material using the hardness test?
- Why wouldn’t it be useful to carry out a hardness test on rocks?

TEACHER NOTES

SUGGESTIONS FOR ASSESSMENT

Minerals are inorganic solids that occur naturally on the Earth.

Inorganic means that the minerals were formed from substances that were never alive. Minerals don't include the remains of plants or animals. A mineral is usually made up of crystals. These can be identified by properties such as colour, hardness, and crystal form. Minerals look the same inside and out.

Minerals are the building blocks of **rocks**. Rocks are mixtures of minerals and vary in the number and amount of minerals present.

Moh's Scale of Mineral Hardness is a scale in common usage that measures the resistance of minerals to scratching.

1 - talc

2 - gypsum

3 - calcite

4 - fluorite

5 - apatite

6 - feldspar

7 - quartz

8 - topaz

9 - corundum

10 - diamond

A mineral can be scratched by any other mineral that has a higher number on the Moh's Scale. For example, gypsum can only scratch talc, but gypsum can be scratched by calcite, fluorite, apatite, etc.

Science Journal Entry: Rock or Mineral

Have students answer the following questions in their science journals:

1. What is the definition of a rock?
2. What is the definition of a mineral?

Look for

- rocks are made up of minerals
- minerals are the same throughout and make up rocks

PRESCRIBED LEARNING OUTCOMES
<i>Students will...</i>
<p>4-4-05 Compare rocks and minerals from the local environment with each other and with those from other geological areas. GLO: C2, D5, E1</p>
<p>4-0-1a. Ask questions that lead to investigations of living things, objects, and events in the local environment. (ELA 1.2.4, 3.1.2) GLO: A1, C2, C5</p> <p>4-0-2a. Access information using a variety of sources. <i>Examples: school libraries, videos, traditional knowledge, CD-ROMs, Internet...</i> (ELA 3.2.2, 3.2.4, TFS 2.1.1) GLO: C6</p> <p>4-0-6e. Evaluate, with guidance, the methods used to answer a question or solve a problem. GLO: C2, C3</p> <p>4-0-7a. Draw a conclusion based on evidence gathered through research and observation. GLO: A1, A2, C2</p>
<p>4-4-06 Give examples of products derived from rocks and minerals. <i>Examples: china, chalk, jewellery, pumice stone, drywall, talcum powder...</i> GLO: B1</p> <p>4-4-07 Describe how characteristics of rocks and properties of minerals determine their uses. <i>Examples: soft soapstone is used for carving...</i> GLO: B1, D3, D5</p>

SUGGESTIONS FOR INSTRUCTION

- **Local Rock Collections**
Have students examine the locally gathered rocks and minerals they brought in to class. Students should label their rocks according to where they were found and use simple identification guides to identify the samples.
- **Inquiry about Rocks and Minerals**
With students, pose questions about the differences and similarities among the rocks and minerals found locally compared with those found in other locations. Inquiry questions may include the following:
 - What types of rocks and minerals are found locally?
 - Are the same rocks and minerals found throughout Manitoba? Throughout Canada? Why or why not?

Use an I-Chart (Hoffman, 1992) to facilitate a whole class inquiry. Have students analyze pictures, charts, maps, graphs, or diagrams to find information or to answer inquiry questions about minerals and rocks from Manitoba and the various geographical areas. (Link to outcome 4-4-08.) (Note: The I-Chart is discussed in *ELA, Strategies*, pp. 83-87.)
- **Guest Presenter**
Invite a geologist to share information and examples about his/her work. Help students to prepare for the visit by brainstorming and developing questions to ask.
- **Field Trip**
Visit a local site such as a quarry or mine, or arrange for a trip to a museum to learn about rocks or minerals found locally.
- **What’s It Made From?**
Have students listen to, read, or view texts that will provide them with information about products or objects that are derived from rocks and minerals. Include resources that cover a range of multi-cultural examples. For example, Inukshuks are used in the Canadian North as landmarks. “Grandfather” rocks are used by Plains and other cultures in sweat ceremonies. Afterwards, have students brainstorm the properties that allow that rock or mineral to be used in that way. Have students work with a partner to complete a chart such as the one shown below.

(continued)

TEACHER NOTES

SUGGESTIONS FOR ASSESSMENT

Refer to Blackline Masters: 12-15 for Geologic Maps of Canada and Manitoba.

Observation Checklist: Rocks and Minerals Inquiry

The student

- asks questions that lead to investigations of rocks
- makes predictions based on observed patterns, collected data, or data provided from other sources
- accesses information from a variety of sources
- identifies problem as they arise and works with others to find solutions
- works cooperatively
- shares group roles and responsibilities
- communicates questions, ideas, and intentions
- uses tools and apparatus safely
- records observations in a variety of ways
- draws a conclusion based on evidence gathered through research and observation

PRESCRIBED LEARNING OUTCOMES

SUGGESTIONS FOR INSTRUCTION

Students will...

<u>Object</u>	<u>Type of Rock</u>	<u>Properties</u>
Inuit carving	soapstone	soft, opaque, can be carved
building	limestone	readily available, strong, yet can be cut
chalk	gypsum	soft, good writing instrument
coal	sedimentary	fuel, organic remains
diamond	diamond	hard, lustre

➤ **Product Collage**

Have students make a collage of products that are derived from rocks and minerals. Students may choose a theme for their collages, such as “In the Art Studio,” “In the Home,” etc.

➤ **Science Journals**

Have students finish the following prompts in their science journals:

1. Objects in the school that come from rocks include _____ . (List five things.)
2. Objects at home that come from rocks are _____ . (List five things.)
3. The most interesting thing I learned about rocks and minerals was _____ .

4-4-08 Recognize that there are three types of rock, and describe how each is formed.
 Include: igneous, sedimentary, metamorphic.
 GLO: D5

➤ **How Did You Make that Rock?**

As a class, read and view informational texts including books, illustrations, CD-ROMs, videos, etc., to gather information on how rocks are formed. Divide students into small groups and assign each group the topics: igneous, metamorphic, or sedimentary rocks. Have students create a short presentation illustrating how their type of rock is formed. This could take the form of a rap song, a skit, a poster, etc.

4-0-2a. Access information using a variety of sources. *Examples: school libraries, videos, traditional knowledge, CD-ROMs, Internet...* (ELA 3.2.2, 3.2.4, TFS 2.1.1) GLO: C6
4-0-2b. Review information to determine its usefulness to inquiry or research needs. (ELA 3.2.3, 3.3.3) GLO: C6, C8
4-0-7e. Communicate results and conclusions in a variety of ways. *Examples: point-form lists, sentences, graphs, labelled diagrams, charts...* (ELA 2.3.5, 4.2.5; Math SP-III.1.4, SP-III.2.4; TFS 2.1.4) GLO: C6

TEACHER NOTES

SUGGESTIONS FOR ASSESSMENT

Igneous rocks derive from the cooling of magma (melted rocks and minerals) formed by volcanoes. Examples include pumice, basalt, and granite.

Sedimentary rocks are rocks made of sediment (sand, mud, pebbles, silt) that settles in layers on the ground and at the bottom of lakes and oceans. The weight of the layers eventually compresses them into rock. Often, plant or animal remains are trapped in the layers and can result in fossil formation. Examples include sandstone, limestone, and shale.

Metamorphic rocks are rocks changed from their original form by heat and pressure below the Earth's surface. Examples include marble, slate, and gneiss.

Learning Log Entry: How Did You Make that Rock?

Have students list the three types of rocks and explain how each type is formed.

Look for

- igneous - from cooling magma formed by volcanoes
- sedimentary - made of sediment that settles in layers; pressure eventually compresses the layers into rocks
- metamorphic - rocks changed from their original form by heat and pressure below the Earth's surface

PRESCRIBED LEARNING OUTCOMES
<i>Students will...</i>
<p>4-4-09 Explain how fossils are formed. GLO: D1, D5, E3</p> <p>4-4-10 Describe how fossils help humans gain a better understanding of Earth’s history, including identifying organisms that are now extinct. GLO: A1, A2, D1, D5</p>
<p>4-0-2a. Access information using a variety of sources. <i>Examples: school libraries, videos, traditional knowledge, CD-ROMs, Internet...</i> (ELA 3.2.2, 3.2.4, TFS 2.1.1) GLO: C6</p> <p>4-0-2b. Review information to determine its usefulness to inquiry or research needs. (ELA 3.2.3, 3.3.3) GLO: C6, C8</p> <p>4-0-8b. Recognize that scientists must support their explanations using evidence and scientific knowledge. GLO: A1, A2, C2</p>
<p>4-4-11 Investigate and describe ways in which rock contributes to soil formation. GLO: D5, E2, E3</p> <p>4-4-12 Investigate and describe ways in which soil erosion is controlled or minimized in their community and in communities around the world. <i>Examples: windbreaks, retaining walls, terracing, cover crops, reforestation...</i> GLO: A5, B1, B5</p> <p style="text-align: right;">(continued)</p>

SUGGESTIONS FOR INSTRUCTION

- **Observing the Environment — A Fossil Walk**
If possible, have students visit local buildings that contain limestone. Have students go on a fossil hunt and complete rubbings or drawings of the fossils they find.
- **What Are Fossils?**
Use KWL (Ogle, 1986) to organize a study of fossils. Together, brainstorm and list everything students know and think they know about fossils. Have students then pose questions that tell what they want to find out. Guide students’ questions to focus on the following questions:
 - How are fossils formed?
 - Where are most fossils found in Manitoba? In Canada?
 - Why are they found there?
 Students then research by viewing videos and filmstrips and reading books and articles to find answers to their questions. They discuss findings and synthesize information. New ideas are grouped together and listed under the L column. (Note: KWL is discussed in *ELA, Strategies*, pp. 89-91.)
- **What Can Fossils Tell Us?**
Have students prepare a short biography of a famous paleontologist, including what discovery he/she made and how this has helped us to gain an understanding of Earth’s history. Students should present their information to the class.
- **Breaking Down Rocks**
Have students place two to three clean rocks in a plastic container with a small amount of water and shake the container for one minute. (For this learning experience, choose at least one rock specimen that is soft.) Have students open the container and observe what happened. Have students reflect on the activity by asking the following reflection questions:
 - What would you call the particles collected in the container?
 - In nature, what would cause the rocks to rub together and wear away?

(continued)

TEACHER NOTES

SUGGESTIONS FOR ASSESSMENT

Manitoba limestone from the Garson-Tyndall area of Manitoba is a common building material throughout Manitoba, Canada, and the world. It can be found in the Manitoba Legislative building and in numerous local town halls, post offices, libraries, and schools. Fossils in this type of limestone are from the Ordovician Period and contain earlier marine fossils such as trilobites, jellyfish, and coral, as opposed to the later-period dinosaurs.

See Blackline Master 12: Geologic Map of Canada, and Blackline Master 14: Geologic Map of Manitoba to locate fossil regions.

Paper and Pencil Task: Fossils

Name: _____ Date: _____

1. Explain how fossils are formed. _____

2. If you were going to search for fossils in Manitoba, where would the best place be to look? Explain your thinking.

3. Fossils help humans understand Earth's history. Do you agree or disagree with this statement? Explain your answer. _____

PRESCRIBED LEARNING OUTCOMES
<i>Students will...</i>
<p>4-0-4f. Assume roles, and share responsibilities as group members. (ELA 5.2.2) GLO: C7</p> <p>4-0-4h. Use tools and apparatus in a manner that ensures personal safety and the safety of others. GLO: C1</p>
This area is intentionally left blank for additional notes or content

SUGGESTIONS FOR INSTRUCTION

- **Centres: Exploring Erosion**
 Have students explore the effects of water and wind on sand through centres. At each centre have students record their observations using the following questions:
 - What effect did the wind/water have on the sand (include labelled diagrams)?
 - How could the erosion observed be prevented?
 Centres might include the following ideas and materials:
 Centre 1 - The effects of wind. Materials: small electric fan or hair dryer, container of sand.
 Centre 2 - The effects of water. Materials: container of sand, supply of water, small watering can or cup with holes.

- **Observing the Environment — Controlling Erosion**
 Have students take a neighbourhood walk to observe ways people control erosion. Methods can include edging around gardens, retaining walls, windbreaks, stone jetties, mulch, plantings, etc. Invite a local farmer to the class to talk about methods used to control erosion in agriculture.

- **Inquiry: Controlling Erosion Around the World**
 Have students use the I-Chart to develop a class inquiry on methods for controlling erosion around the world. As a class, develop questions to guide the inquiry. Have each group research a different country or different type of erosion control. Have students use the Jigsaw method (Aronson, Blaney, Silkes, and Snapp, 1978) to teach each other about their findings. (See *Success for All Learners*, 5.9.)

TEACHER NOTES

SUGGESTIONS FOR ASSESSMENT

PRESCRIBED LEARNING OUTCOMES
<i>Students will...</i>
<p>4-4-13 Use the design process to determine an appropriate system for controlling soil erosion in a given situation. GLO: B1, B5, C3, E3</p>
<p>4-0-1c. Identify practical problems to solve in the local environment. GLO: C3 4-0-3d. Brainstorm possible solutions to a practical problem, and identify and justify which solution to implement. (ELA 1.2.3) GLO: C3 4-0-3e. Create a written plan to solve a problem or meet a need. Include: identify steps to follow, prepare a labelled diagram. GLO: C3 4-0-3f. Develop criteria to evaluate an object, device, or system based on its function, aesthetics, and other considerations such as materials, and cost. GLO: C3 4-0-4b. Construct an object, device, or system to solve a problem or meet a need. GLO: C3 4-0-4c. Test an object, device, or system with respect to pre-determined criteria. GLO: C3, C5 4-0-4d. Identify and make improvements to an object, device, or system, and explain the rationale for the changes. GLO: C3 4-0-7c. Identify new problems that arise. GLO: C3 4-0-8c. Recognize that designing a solution to a simple problem may have considerations, such as cost, materials, time, and space. GLO: B2, C3</p>

SUGGESTIONS FOR INSTRUCTION

➤ **Design Process: Controlling Soil Erosion**

Present a scenario to students such as: A farm couple whose land is on a hill keep losing their soil when it rains. They have a small amount of land with very fertile soil. What can they do to control erosion?

Have students work in small groups to brainstorm and create a written plan (labelled diagram) for the system they would recommend. Materials for a working model should be identified. When the plans are completed and materials gathered, have students visit a local sandbox to create a model of their farm, install their erosion control system, and test its effectiveness using a watering can. Evaluation criteria can include the following elements:

- shows a reduction in the amount of earth (sand) that is washed away
- includes detailed drawing
- utilizes method(s) of erosion control learned about during the cluster
- includes justification for choice of system

TEACHER NOTES

SUGGESTIONS FOR ASSESSMENT

Have students use Blackline Master 4: Design Process Recording Sheet: Grades 3 and 4.

Design Process Checklist

The student

- understands the problem
- brainstorms possible solutions
- creates a written plan
- develops criteria for success
- includes labelled diagram
- designs an appropriate system
- tests the system
- identifies and makes improvements
- identifies new problems that arise
- recognizes that designing a solution may involve cost and materials

PRESCRIBED LEARNING OUTCOMES
<i>Students will...</i>
<p>4-4-14 Describe effects of wind, water, and ice on the landscape.</p> <p><i>Examples: ice breaking rocks into soil, wind shaping sand dunes, waves polishing rocks on the shoreline...</i></p> <p>GLO: D5, E3</p>
<p>4-0-4g. Communicate questions, ideas and intentions, and listen effectively to others during classroom-learning experiences. GLO: C6</p> <p>4-0-5c. Record observations in a variety of ways. Examples: point-form notes, sentences, labelled diagrams, charts... (ELA 2.1.1, 3.3.1, 4.1.1, 4.1.2; Math SP-1.2.4, SP-II.2.4) GLO: C2, C6</p>

SUGGESTIONS FOR INSTRUCTION

➤ **Landscape Images**

Have students create an image (using paint, felt-tip markers, coloured pencils, etc.) that portrays the effects of wind, water, or ice on a particular landscape. Students should use this activity to apply their learning about these effects. Have students combine pictures from magazines with their own drawings. Have students make notes based on the landscape images, summarizing the different effects.

<p>4-4-15 Identify natural phenomena and human activities that cause significant changes in the landscape.</p> <p><i>Examples: floods, avalanches, mud slides, hydroelectric dams, clearing land for agriculture, clear-cut forestry, forest fires...</i></p> <p>GLO: B5, D5, E3</p>

➤ **Changing the Landscape**

With students, develop a list of natural and human-caused phenomena that cause significant changes in landscapes.

Example:

Landscape Changes

Natural	Human-Caused
avalanches	dams
mudslides	agriculture/farming
floods	forestry
forest fires	urban housing

➤ **Telling a Story**

Have students write a story from the viewpoint of a large boulder or rock outcrop, observing what happens to the surrounding area over a period of a hundred years. Stories should include both human and natural changes.

TEACHER NOTES

SUGGESTIONS FOR ASSESSMENT

At this point the emphasis is on recognizing that the landscape is ever-changing and that there are certain natural and human-caused events that can cause the landscape to change even more rapidly. Emphasis should not be placed on making judgements about good or bad, right or wrong.

Scoring Rubric: Telling a Story

Scale	Natural Phenomena	Human Activities	Communication
4	at least four examples included	at least four examples given	detailed, clear and well written
3	at least three examples included	at least three examples given	complete and well written
2	at least two examples included	at least two examples given	complete but may be unclear or lacks detail
1	at least one example included	at least one example given	incomplete

NOTES

Appendices

APPENDIX A: GENERAL LEARNING OUTCOMES*

The purpose of Manitoba science curricula is to help students gain a measure of scientific literacy that will assist them in becoming informed, productive, and fulfilled members of society. As a result of their Early, Middle, and Senior Years science education Manitoba students will be able to:

Nature of Science and Technology

- A1. recognize both the power and limitations of science as a way of answering questions about the world and explaining natural phenomena
- A2. recognize that scientific knowledge is based on evidence, models, and explanations, and evolves as new evidence appears and new conceptualizations develop
- A3. distinguish critically between science and technology in terms of their respective contexts, goals, methods, products, and values
- A4. identify and appreciate contributions made by women and men from many societies and cultural backgrounds towards increasing our understanding of the world and in bringing about technological innovations
- A5. recognize that science and technology interact with and advance one another

Science, Technology, Society, and the Environment (STSE)

- B1. describe scientific and technological developments, past and present, and appreciate their impact on individuals, societies, and the environment, both locally and globally
- B2. recognize that scientific and technological endeavours have been and continue to be influenced by human needs and the societal context of the time
- B3. identify the factors that affect health and explain the relationships among personal habits, lifestyle choices, and human health, both individual and social
- B4. demonstrate a knowledge of, and personal consideration for, a range of possible science- and technology-related interests, hobbies, and careers
- B5. identify and demonstrate actions that promote a sustainable environment, society, and economy, both locally and globally

Scientific and Technological Skills and Attitudes

- C1. recognize safety symbols and practices related to scientific and technological activities and to their daily lives, and apply this knowledge in appropriate situations
- C2. demonstrate appropriate scientific inquiry skills when seeking answers to questions
- C3. demonstrate appropriate problem-solving skills while seeking solutions to technological challenges

*Source: The general learning outcomes are identified in Manitoba Education and Training. *Kindergarten to Grade 4 Science: Manitoba Curriculum Framework of Outcomes*. Renewing Education: New Directions series. Winnipeg, MB: Manitoba Education and Training, 1999.

- C4. demonstrate appropriate critical thinking and decision-making skills when choosing a course of action based on scientific and technological information
- C5. demonstrate curiosity, skepticism, creativity, open-mindedness, accuracy, precision, honesty, and persistence, and appreciate their importance as scientific and technological habits of mind
- C6. employ effective communication skills and utilize information technology to gather and share scientific and technological ideas and data
- C7. work cooperatively and value the ideas and contributions of others while carrying out scientific and technological activities
- C8. evaluate, from a scientific perspective, information and ideas encountered during investigations and in daily life

Essential Science Knowledge

- D1. understand essential life structures and processes pertaining to a wide variety of organisms, including humans
- D2. understand various biotic and abiotic components of ecosystems, as well as their interaction and interdependence within ecosystems and within the biosphere as a whole
- D3. understand the properties and structures of matter, as well as various common manifestations and applications of the actions and interactions of matter
- D4. understand how stability, motion, forces, and energy transfers and transformations play a role in a wide range of natural and constructed contexts
- D5. understand the composition of the Earth's atmosphere, hydrosphere, and lithosphere, as well as the processes involved within and among them
- D6. understand the composition of the universe, the interactions within it, and the impacts of humankind's continued attempts to understand and explore it

Unifying Concepts

- E1. describe and appreciate the similarity and diversity of forms, functions, and patterns within the natural and constructed world
- E2. describe and appreciate how the natural and constructed world is made up of systems and how interactions take place within and among these systems
- E3. recognize that characteristics of materials and systems can remain constant or change over time, and describe the conditions and processes involved
- E4. recognize that energy, whether transmitted or transformed, is the driving force of both movement and change, and is inherent within materials and in the interactions among them

APPENDIX B: SELECTING SCIENCE-BASED LITERATURE

Science-Based Factual Literature (Non-Fiction Resources)

Science-based factual literature (also referred to as non-fiction or information trade books) provides an extensive range and variety of science learning resources. The selection and use of high-quality, science-based factual literature enhances students' interest in and enjoyment of science. Teachers can use non-fiction resources for exploring science concepts and gaining ideas for instructional strategies.

The attractive and interesting formats and dynamic use of visual information in effective science-based non-fiction books appeals to students. There are two common formats. One involves the presentation of information in a narrative or “story” style. The other organizes and structures information for ease of research, using headings and sub-headings.

Science-based factual literature should

- present science concepts accurately
- contain current information
- use correct scientific vocabulary that is age-appropriate for the intended audience
- have a variety of visual cues, such as charts, images, labelled diagrams, captioned pictures
- capture students' interest and spark their curiosity

Science-Based Narrative Literature (Fiction Resources)

The use of a variety of forms and genres of narrative texts is a key element in the development of literacy in Early Years classrooms. Science-based narrative texts support the development of literacy skills and knowledge of science concepts.

Learning resources that successfully integrate science with children's narrative literature include

- a strong and obvious science concept or theme flowing throughout the story
- relevant science vocabulary
- a motivational approach that stimulates discussion and arouses curiosity
- illustrations that complement and enhance the textual information

The use of the above criteria for the selection of science-focussed narrative literature will maximize the effectiveness of teaching science through an interdisciplinary approach. This integration can enhance both literacy and science learning.

The use of a variety of genres of narrative texts accommodates student diversity in prior knowledge, experience, and learning approaches. Several literary sources focussing on the same scientific concept or theme should be used, including rhymes, picture books, poetry, songs, and short stories.

The use of science-based narrative literature should lend itself to follow-up, hands-on learning experiences that focus on skills and strategies connected to science-concept development.

APPENDIX C: THE MANITOBA CLEAN WATER GUIDE

WHAT YOU CAN DO*

In General

- Turn taps off tightly so they do not drip.
- Repair tap, faucet, pipe, and hose leaks promptly.
- Use low-flow faucet aerators.

In the Kitchen

- Only use a dishwasher when full; use the cycle that requires the least water.
- Hand wash dishes in a partly filled sink. Instead of using running water to rinse dishes, fill a separate sink or use the faucet spray attachment.
- Keep a container of drinking water in the refrigerator instead of running tap water until it is cold.

In the Bathroom

- Use a partially filled sink rather than running water continuously while washing your hands.
- Check for toilet tank leaks and repair them promptly.
- Short showers use less water than baths; use a low-flow showerhead.
- For bathing, fill only half the tub with water.
- Toilets use the largest proportion of household water—about 40%. Use toilets only for their intended purpose—do not flush paper towels, cotton swabs, or cigarette butts. Never flush paints, solvents, pesticides, or other chemicals, since these are hazardous to the aquatic environment.
- A toilet dam or weighted plastic bottle in the toilet tank can reduce water use.
- Low-flush toilets are available and are practical for home and cottage use.

Laundry

- Only use the washing machine when full; use the cycle that requires the least water.
- Adjust the water level if smaller washes are necessary.
- If you have a septic system, limit the number of loads per day to avoid overloading it.

(continued)

*Source: *The Manitoba Clean Water Guide*, p. 14. Reproduced with permission of Manitoba Environment, 1999. This document is available on Manitoba Environment's website at <<http://www.gov.mb.ca/enviro/pages/publs97/cwgtext/cover.html>>

Outdoors

- Water your lawn only when it needs it. Lawns require only 2-3 centimetres of water per week. Some sprinklers have an attached measuring well to determine the volume of water used. You can determine it yourself by collecting water in a pan.
- To reduce water evaporation, water in early morning or late afternoon and avoid watering on windy days.
- Drip irrigation or soaker hoses are the best methods for conserving water while watering plants.
- A low-level sprinkler is the best type to use for watering the lawn; an oscillating sprinkler loses up to 50% of the water to evaporation.
- Cut your grass to a height of 5-8 centimetres and leave the grass clippings on the lawn. This shades their roots during hot weather, and will help retain moisture.
- Shrubs and young trees usually require watering only once a week.
- Transplanted or young garden plants should be watered more often with small quantities of water until they become well established.
- Use organic mulch around plants and trees and incorporate compost into your garden soil to help retain moisture.
- Washing your car with running water can use up to 400 litres of water. Use a bucket, a sponge, and a trigger nozzle on the hose to reduce water consumption.
- Instead of washing leaves, soil, and debris off a driveway or sidewalk, use a rake and broom.

APPENDIX D: PETS IN THE CLASSROOM*

When we think of classroom pets, we often imagine small mammals such as gerbils, hamsters, or guinea pigs. While these are interesting creatures to observe, hamsters and gerbils are nocturnal animals and, as such, tend to be rather sleepy during the day. In fact, one group of Grade 1 students once questioned whether or not there was a real animal in the hamster cage. The children would occasionally annoy the hamster into activity, but for the most part, he remained an unseen fixture of the classroom.

Generally speaking, most animals in the classroom are best left as visitors, rather than residents. It is expected that students will have opportunities to observe living creatures, but this can be accomplished by having animals as special visitors for a period of time. Of course, teachers should outline strict guidelines for the safety of the animals, ensuring that they undergo as little stress as possible. Teachers must also be aware of allergies the students might have, especially to fur-bearing animals.

Teachers who are planning to maintain a “classroom pet” for any period of time need to recognize that all vertebrate animals have important dietary and housing concerns that require time, expertise, and care to address.

Birds, for the most part, do not make good classroom pets. Some, like the budgie or any member of the parrot family, can be carriers of parrot fever and should not be housed in a school or classroom. Other birds, such as finches, canaries, or pin quail, are sensitive to temperature changes and require large flight pens to move around comfortably.

Reptiles and amphibians require very specific environments and carefully designed diets. Being cold-blooded, these animals will endure a slow death of starvation if their dietary needs are not met. Turtles, of course, must be avoided in classrooms, due to concerns regarding salmonella. Amphibians, such as frogs, are sensitive to temperature and humidity changes and require large environments so that they have suitable ranges for movement.

Exotic pets of all types need not be resident in schools or classrooms. Large and small snakes, tropical birds, monkeys, and reptiles are interesting creatures for students to observe. However, with the availability of media today, there is no reason for these animals to be long-term “classroom pets.”

Wild animals may carry potentially dangerous pathogens, and must not be brought into classrooms unless under the care of a knowledgeable expert. Animals found by students and brought into school (such as raccoon babies, injured squirrels, small snakes, and other creatures) should be directed to a local humane shelter or wildlife rescue organization.

Small fish make good classroom pets. With proper housing, feeding schedules, and cleaning, an aquarium can house a collection of small fish, readily available from most pet stores. Teachers should avoid keeping fancy tropical fish in their classrooms. Fish can be sensitive to light and temperature changes — some schools turn down their heating over the weekends in wintertime, making heaters essential for aquaria. Feeding schedules must be maintained. While it may seem that classroom fish can make it through a holiday weekend without being fed such fasting periods put undue stress on the fish and make them far more susceptible to diseases.

*Source: “Keeping Animals in the Classroom—A Guide.” Implementation Planning Workshop for *The Ontario Curriculum, Grades 1-8: Science and Technology*. © Queen’s Printer for Ontario, 1998. Adapted with permission.

Invertebrates can make good classroom pets. These pets are relatively easy to maintain. They require minimal amounts of space and small quantities of food. Of course, teachers have to be aware of their environmental and dietary needs.

The following guide provides some general classroom care information regarding the needs of a variety of living things. This guide should be used PRIOR to having an animal in the classroom. It is, by no means, comprehensive, but rather gives teachers some information about the dietary and environmental needs of a number of animals they may wish to have as classroom visitors.

Organism	Housing	Temperature Range	Food	Causes of Failure	Remarks
Aquatic Snails	aquaria	24 ° - 29 °C	lettuce	lack of food, drastic temperature changes	include in culture with guppies
Brine Shrimp	8 litre container or aquaria	21° - 27° C	diluted yeast solution	overfeeding, lack of oxygen, overcrowding	raise in a 3-5% solution of non-iodized salt
Chameleons-Anoles	large aquarium with screened lid	27° - 32° C	live crickets, occasional mealworm	overcrowding or lack of water/food	spray droplets or water on sides of container daily
Earthworms	organic soil in wooden or plastic box	13° - 18° C	mashed potatoes, lettuce, coffee grounds	too much heat, too much or not enough moisture, overcrowding	buss bedding works well in place of soil, keep covered
Guppies	aquaria, 8 litre container	24° - 29° C	prepared fish food, brine shrimp	excessive food	change water occasionally, include numerous aquatic plants
Mealworms	8 litre container or larger, plastic shoe box	16° - 27° C	bran, dog food, occasional apple or potato slice	mould growth from too much water	cover top of bran with cotton, sprinkle water on cotton
Newts	8 litre container, terrarium	17° - 28° C	live food, daphnia, brine shrimp or liver bits	lack of food, escape easily, no dry place	move liver when feeding (looks alive), provide dry resting place
Butterflies (painted lady)	large box with sides cut out; openings covered with screen	21° - 27° C	larvae-artificial media, adult -5% sugar water	humidity not correct	add containers of moist sand to adult container
Milkweed Bug	plastic shoe boxes or similar containers	10° - 35° C	milkweed seeds, shelled unsalted sunflower seeds	excessive mould on food, too much moisture	easily raised, good example of incomplete metamorphosis

APPENDIX E: USING LEARNING CENTRES IN THE SCIENCE CLASSROOM

Learning centres are generally small, designated sections of the classroom that may range from a temporary table set-up to a more developed permanent area or space. Successful learning centres are dynamic and inviting. Their purpose should be clearly expressed to students and be developmentally appropriate for all students in the class, providing a range of learning experiences and investigations. Centres include a variety of materials and well-organized sets of basic supplies to be manipulated and explored by small groups of students at a time. Science centres are essential components of Early Years classrooms.

Learning centres promote self-directed learning. They motivate, guide, and support students, providing them with repeated opportunities to test ideas, take risks, and work at their own pace to complete the task at hand. Learning centres also allow students to work together, share, and develop skills in cooperation and leadership. As they manipulate materials, students take ownership of their learning and contribute to the learning of others. Centres allow students to gain confidence in their own abilities and develop collaboration, communication, and mutual respect. The teacher serves as the facilitator and not the expositor of knowledge during centre time. The use of centres requires that some time be spent teaching cooperative and collaborative learning skills.

Centres can be used to promote inter-disciplinary investigations around a central science-focussed theme. Language is used throughout for sharing materials, solving problems, clarifying learning, and recording information. For example, if centres are established around the theme of “plants,” they might have specific disciplinary emphases.

Sample: Centres for a Plant Theme

Disciplinary Focus	How Learning Centres Address Science Themes
Mathematics	Measuring and recording changes as plants grow; graphing results
Reading	Reading fiction and non-fiction texts related to plants; researching to determine which plants begin as seeds, bulbs, cuttings, etc.
Writing	Writing stories, poems, raps, or songs about plants
Science	Carrying out investigations related to sorting and classifying plants, objects made from plants, and/or foods that come from plants; planning and recording plant experiments
Art	Observing and drawing different plants; making recycled paper; experimenting with colour, shape, texture, and pattern
Social Studies	Determining the types of plants that grow in the community; describing the location for each; investigating global products made from plants

Effective use of learning centres enables teachers to circulate and ask questions to develop student thinking. Teachers should assist students who are experiencing difficulty. At times, teachers may select a particular centre for assessment purposes and remain there until all students cycle through. Some form of recording and/or debriefing should follow centre investigations/tasks.

Learning centres allow teachers to integrate many curricular areas, thus enabling students to meet learning outcomes from several subject areas. Centre work can be assessed through observational checklists/notes, peer- and self-assessment, journal/learning log entries, and marking of finished products.

Kindergarten to Grade 4 Science: A Foundation for Implementation provides ideas for learning centres in the Suggestions for Instruction column. These ideas are meant as suggestions only and are not the only places where centres can be used to achieve student learning outcomes. Teachers are encouraged to make their own decisions as to the most appropriate time and place to use centres.

NOTES

References

REFERENCES

- Agriculture in the Classroom. *Discover Agriculture: Science Curriculum Activities: For Teachers of Grades 4-6 Science*. Winnipeg, MB: Agriculture in the Classroom, 1997.
- — — . *Discover Agriculture: Science Projects for Grades 4-6 Students*. Winnipeg, MB: Agriculture in the Classroom, 1997.
- Alberta Education. *Program of Studies – Elementary Schools: Science*. Edmonton, AB: Alberta Education, 1995.
- American Association for the Advancement of Science. *Benchmarks for Science Literacy: Project 2061*. New York, NY: Oxford University Press, 1993.
- Aronson, E., N. Blaney, C. Stephan, J. Silkes, and M. Snapp. *The Jigsaw Classroom*. Beverly Hills, CA: Sage, 1978.
- Brownlie, Faye, and Susan Close. *Beyond Chalk and Talk: Collaborative Strategies for the Middle and High School Years*. Markham, ON: Pembroke, 1992.
- Bybee, Rodger W. *Science and Technology Education for the Elementary Years: Frameworks for Curriculum and Instruction*. Rowley, MA: The National Center for Improving Science Education (The Network), 1989.
- Butzow, Carol M., and John W. Butzow. *Science Through Children's Literature - An Integrated Approach*. Englewood, CO: Teacher Ideas Press, 1989.
- Canadian Wildlife Federation. *Project Wild Activity Guide*. Ottawa, ON: Canadian Wildlife Federation, 1998.
- City of Winnipeg Water and Waste Department. *Slow the Flow: Teacher's Manual*. Winnipeg, MB: City of Winnipeg, 1999.
- — — . *Slow the Flow: Student Lesson Package*. Winnipeg, MB: City of Winnipeg, 1999.
- Connors, T. Wayne, Richard F. Coombs, Grant A. Gardner, Juanita Keel-Ryan, David H. Rendell, and Frederick R. Smith. *Science Fare: A Practical Guide for Parents and Students*. Markham, ON: Sciencefare Press, Inc., 1988.

- Council of Ministers of Education, Canada. *Common Framework of Science Learning Outcomes K to 12: Pan-Canadian Protocol for Collaboration on School Curriculum*. Toronto, ON: Council of Ministers of Education, Canada 1997.
- — — . *Science Assessment: Framework and Criteria, School Achievement Indicators Program SAIP*. Toronto, ON: Council of Ministers of Education, 1996.
- Conseil supérieur de l'éducation. *Améliorer l'éducation scientifique sans compromettre l'orientation des élèves : les sciences de la nature et la mathématique au deuxième cycle du secondaire*. Montreal, QC: Conseil supérieur de l'éducation, 1990.
- — — . *L'initiation des élèves aux sciences de la nature chez les enfants au primaire*. Montreal, QC: Conseil supérieur de l'éducation, 1989.
- Cunningham, Patricia M. *Phonics They Use: Words for Reading and Writing*. New York, NY: Harper Collins, 1991.
- De Vecchi, G., and A. Giordan. *L'enseignement scientifique : comment faire pour que « ça marche »?* Nice, France: Z éditions, 1988.
- Fountas, Irene C., and Gay Su Pinnell. *Guided Reading: Good First Teaching for All Children*. Portsmouth, NH: Heinemann, 1996.
- Health Canada. *Canada's Food Guide to Healthy Eating*. Ottawa, ON: Minister of Supply and Services, 1997.
- Hodson, D. "In Search of a Rationale for Multicultural Science Education." *Science Education* 77-6 (1993): 685-711.
- Hoffman, James V. "Critical Reading/Thinking Across the Curriculum: Using I-Charts to Support Learning." *Language Arts* 69 (February 1992): 121-27.
- — — . *I-Chart*. Austin, TX: Personal Communication, 1997.
- Koenig, Herbert G., Mary Lou De Marco-Keating, and Janet B. Lansing. *N & N Sciences Series — Competency in Science*. Wayne H. Garnsey, ed. Middleton, NY: N & N Publishing Company, Inc., 1992.
- Lake, Jo-Anne. *Imagine - A Literature-Based Approach to Science*. Markham, ON: Pembroke, 1993.

- Larochelle, M., et J, Désautels. *Autour de l'idée de science: itinéraires cognitifs d'étudiants et d'étudiantes*. Laval, QC: Presses de l'université Laval, 1992.
- Manitoba Education and Training. *A Foundation for Excellence. Renewing Education: New Directions series*. Winnipeg, MB: Manitoba Education and Training, 1995.
- — . *Curricular Connections: Elements of Intergration in the Classroom*. Renewing Education: New Directions series. Winnipeg, MB: Manitoba Education and Training, 1997.
- — . *Grades 5 to 8 Mathematics: A Foundation for Implementation*. Renewing Education: New Directions series. Winnipeg, MB: Manitoba Education and Training, 1997.
- — . *K-4 Mathematics: Manitoba Curriculum Framework of Outcomes and Grade 3 Standards*. Renewing Education: New Directions series. Winnipeg, MB: Manitoba Education and Training, 1995.
- — . *Kindergarten to Grade 4 English Language Arts: A Foundation for Implementation*. Renewing Education: New Directions series. Winnipeg, MB: Manitoba Education and Training, 1996.
- — . *Kindergarten to Grade 4 Mathematics: A Foundation for Implementation*. Renewing Education: New Directions series. Winnipeg, MB: Manitoba Education and Training, 1996.
- — . *Kindergarten to Grade 4 Science: Manitoba Curriculum Framework of Outcomes*. Renewing Education: New Directions series. Winnipeg, MB: Manitoba Education and Training, 1999.
- — . *Native Studies: Early Years (K – 4), A Teacher's Resource Book Framework*. Renewing Education: New Directions series. Winnipeg, MB: Manitoba Education and Training, 1995.
- — . *Reporting on Student Progress and Achievement: A Policy Handbook for Teachers, Administrators, and Parents*. Renewing Education: New Directions series. Winnipeg, MB: Manitoba Education and Training, 1997.
- — . *Science Safety: A Kindergarten to Senior 4 Resource Manual for Teachers, Schools, and School Divisions*. Renewing Education: New Directions series. Winnipeg, MB: Manitoba Education and Training, 1997.

- — — . *Senior 2 English Language Arts: A Foundation for Implementation*. Renewing Education: New Directions series. Winnipeg, MB: Manitoba Education and Training, 1998.
- — — . *Science Grade 3: Interim Guide*. Winnipeg, MB: Manitoba Education and Training, 1991.
- — — . *Senior Years Science Teachers' Handbook: A Teaching Resource*. Renewing Education: New Directions series. Winnipeg, MB: Manitoba Education and Training, 1997.
- — — . *Success for All Learners: A Handbook on Differentiating Instruction: A Resource for Kindergarten to Senior 4 Schools*. Renewing Education: New Directions series. Winnipeg, MB: Manitoba Education and Training, 1996.
- — — . *Technology as a Foundation Skill Area: A Journey Toward Information Technology Literacy*. Renewing Education: New Directions series. Winnipeg, MB: Manitoba Education and Training, 1998.
- Manitoba Environment. *The Manitoba Clean Water Guide*. Winnipeg, MB: Manitoba Environment, Water Quality Management Section, 1999.
- Martin, David Jerner. *Elementary Science Methods: A Constructivist Approach*. Albany, NY: Delmar Publishers, 1997.
- Moline, Steve. *I See What You Mean: Children at Work with Visual Information*. York, ME: Stenhouse, 1995.
- Moon, J., and L. Schulman. *Finding the Connections: Linking Assessment, Instruction, and Curriculum in Elementary Mathematics*. Portsmouth, NH: Heinemann, 1995.
- McTighe, Jay, and Frank T. Lyman. "Mind Tools for Matters of Minds." *If Minds Matter: A Foreword to the Future*. Vol. 2. Eds. Arthur Costa, James Bellanca, and Robin Fogarty. Palatine, IL: IRI/Skylight, 1992.
- National Research Council. *National Science Education Standards*. Washington, DC: National Academy Press, 1996.
- National Science Teachers Association. *NSTA Pathways to the Science Standards: Guidelines for Moving the Vision into Practice*. Elementary School Edition. Ed. Lawrence F. Lowery. Arlington, VA: National Science Teachers Association, 1997.

-
- — — . *Scope, Sequences, and Coordination of Secondary School Science*. Vol. II. Arlington, VA: National Science Teachers Association, 1992.
- — — . *The Content Core: A Guide for Curriculum Designers*. Arlington, VA: National Science Teachers Association, 1993.
- Newfoundland and Labrador Department of Education, Primary, Elementary, and Secondary Education Branch. *Foundation for the Atlantic Canada Science Curriculum*. Newfoundland and Labrador Department of Education, 1998.
- Ogle, D. “The K-W-L: A Teaching Model that Develops Active Reading of Expository Text.” *The Reading Teacher* 39 (1986): 564-70.
- Ontario Ministry of Education and Training. *Keeping Animals in the Classroom — A Guide*. (Implementation Planning Workshop for *The Ontario Curriculum Grades 1-8: Science and Technology*. Toronto, ON: Ministry of Education and Training, 1998.
- — — . *The Ontario Curriculum Grades 1-8: Science and Technology*. Toronto, ON: Ministry of Education and Training, 1998.
- Orpwood, G. and J.P. Souque. *Science Education in Canadian Schools, Background Study 52*. Ottawa, ON: Ministry of Supply and Services, 1984.
- Rutherford, F. James, and Andrew Ahlgren. *Science for All Americans: Project 2061*. New York, NY: Oxford University Press, 1991.
- Santa, C.M. *Content Reading Including Study Systems*. Dubuque, IA: Kendall/Hunt, 1988.
- Saphier, Jonathon D., and Mary Ann Haley. *Activators: Activity Structures to Engage Students’ Thinking Before Instruction*. Carlisle, MA: Research for Better Teaching, 1993.
- Schwartz, Robert M., and T. E. Raphael. “Concept of Definition: A Key to Improve Students’ Vocabulary.” *The Reading Teacher* 39.2 (1985): 198-205.
- Science Council of Canada. *Science for Every Student*. Report 36. Ottawa, ON: Ministry of Supply and Services, 1984.





- Short, Kathy G., and Jerome C. Harste with Carolyn Burke. *Creating Classrooms for Authors and Inquirers*. 2nd ed. Portsmouth, NH: Heinemann, 1996.
- Stanley, W.B., and N.W. Brickhouse. "Multiculturalism, Universalism, and Science Education." *Science Education* 78-4 (1994): 387-398.
- Stauffer, R.G. *Directing Reading Maturity as a Cognitive Process*. New York, NY: Harper and Row, 1969.
- Sustainability Manitoba. *Sustainable Development Strategy for Manitoba*. Winnipeg, MB: Sustainability Manitoba, 1994.
- Tierney, Robert J., John E. Readence, and Ernest K. Dishner. *Reading Strategies and Practices: A Compendium*. 4th ed. Toronto, ON: Allyn and Bacon, 1995.
- United Nations Educational, Scientific and Cultural Organization (UNESCO). "Le développement durable grâce à l'éducation relative à l'environnement." *Connexion* 13.2 (June 1988).
- Woolf, Lawrence D., "Confusing Color Concepts Clarified." *The Physics Teacher* 37 (April 1999): 304-206.
- World Commission on Environment and Development. *Our Common Future*. New York, NY: Oxford University Press, 1987.

Blackline Masters

Scientific Inquiry Recording Sheet: Grades 1 and 2

What is the question? _____

What do I think? _____

 <p>What I used</p>	<p>What I did</p> 
 <p>What I observed</p>	<p>What I found out</p> 

Scientific Inquiry Recording Sheet: Grades 3 and 4

Question:

Prediction:

Materials/Tools:

**Procedure:
(steps followed)**

Observation:

Conclusion:

Next:

Design Process Recording Sheet: Grades 1 and 2

Problem:

My Plan:

What I Need (Materials/Tools):

Reflection:

1. Two things I did well:





2. Next time:

Design Process Recording Sheet: Grades 3 and 4

<p>What I (we) already know:</p> <p>What I (we) still need to find out:</p>	<p>Problem:</p>	<p>Possible solutions:</p>
<p>Criteria:</p>	<p>Plan:</p>	

Design Process Recording Sheet: Grades 3 and 4

<p>Materials/Tools:</p>	<p>Testing My Object/Device</p> <p>What worked:</p> <p>What didn't work:</p>
<p>Improvement plan:</p>	<p>Design Process Reflection</p> <p>What I did well _____</p> <p>_____</p> <p>_____</p> <p>Next time I would (What I need to change) _____</p> <p>_____</p> <p>_____</p> <p>Comments _____</p> <p>_____</p>

BLM 5**How I Worked In My Group***

Name: _____

Date: _____

Task: _____

	Comments
I took turns.	
I participated.	
I encouraged others.	
I shared materials.	
I stayed with my group.	
I listened.	
I accomplished the task.	

*Source: "Assessment Masters: Group Work," in *Kindergarten to Grade 4 Mathematics: A Foundation for Implementation*. Renewing Education: New Directions series. Winnipeg, MB: Manitoba Education and Training, 1996.

How We Worked Together*



BLM 6

Name: _____

Date: _____

Task: _____

Group Members:

	 Yes	 Sometimes	 No
Everyone participated.			
We listened to each other.			
We encouraged each other.			
We took turns sharing ideas.			
The group stayed together.			
We accomplished our task.			

*Source: "Assessment Masters: How We Worked Together," in *Kindergarten to Grade 4 Mathematics: A Foundation for Implementation*. Renewing Education: New Directions series. Winnipeg, MB: Manitoba Education and Training, 1996.

Student Observation Record*
Individual/Group Activity

Student:	Date:	Student:	Date:
Student:	Date:	Student:	Date:
Student:	Date:	Student:	Date:

*Source: "Assessment Masters: Student Observation Record," in *Kindergarten to Grade 4 Mathematics: A Foundation for Implementation*. Renewing Education: New Directions series. Winnipeg, MB: Manitoba Education and Training, 1996.

Student Evaluation Sheet*

Topic: _____

Date: _____

Criteria: _____

Name	Comments	Action/Need

*Source: "Assessment Masters: Student Evaluation Sheet," in *Kindergarten to Grade 4 Mathematics: A Foundation for Implementation*. Renewing Directions series. Winnipeg, MB: Manitoba Education and Training, 1996.

BLM 9

Checklist*

Students' names						Comments

*Source: "Assessment Masters: Checklist," in *Kindergarten to Grade 4 Mathematics: A Foundation for Implementation*. New Directions series. Winnipeg, MB: Manitoba Education and Training, 1996.

Food Sorting Cards



Banana

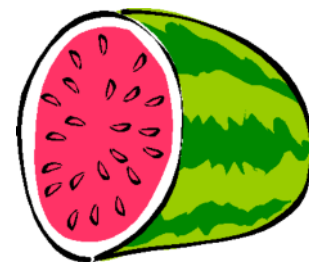

Watermelon



Steak



Sausage



Apple



French Fries



Corn

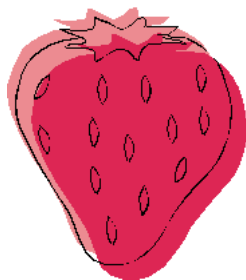

Strawberry



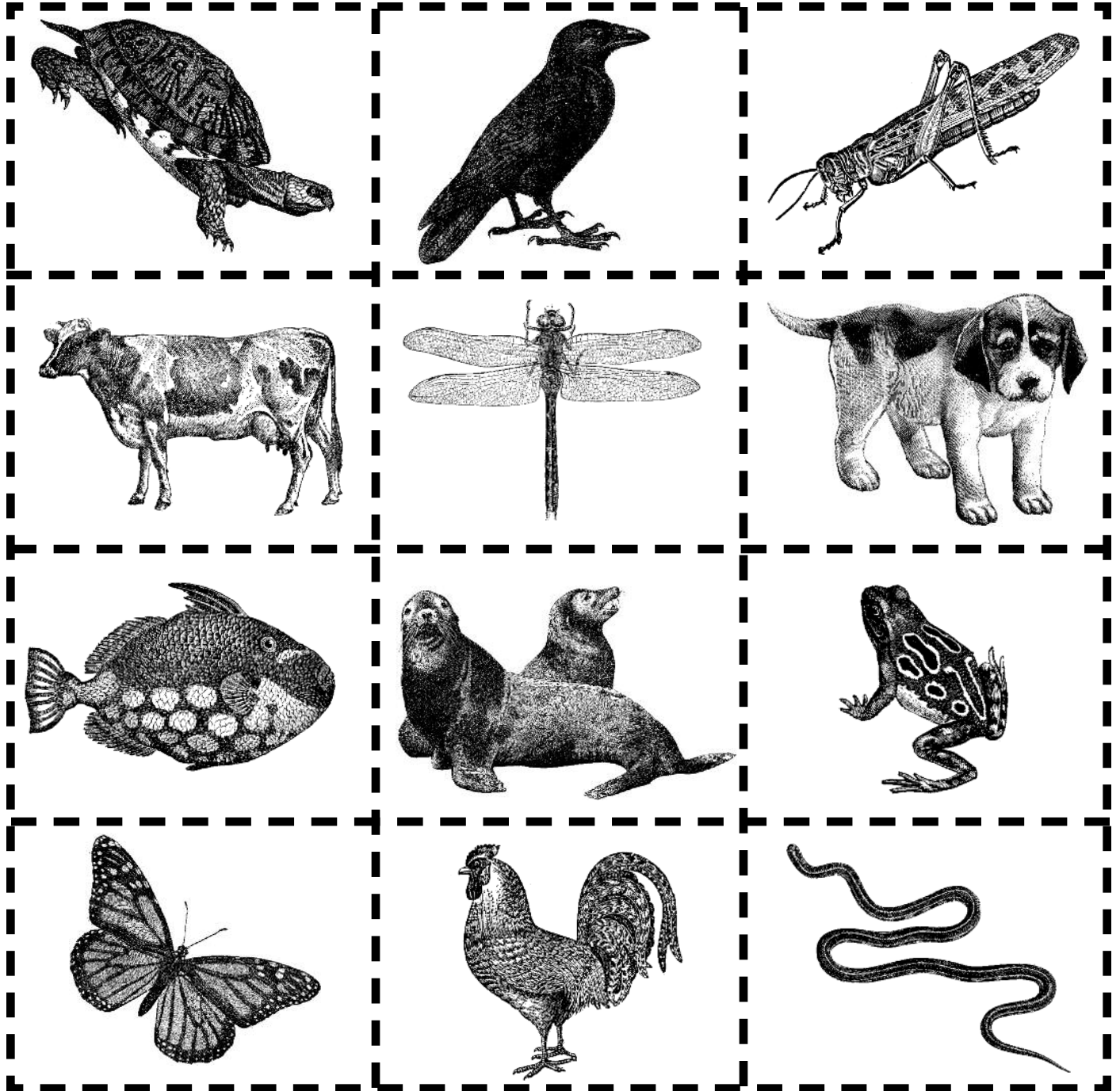

Toast

Animal Sorting Cards



Geological Map of Canada

LEGEND

-  ANCIENT METAMORPHIC ROCKS AND GRANITE; Canada's oldest surface
-  LIMESTONES, SANDSTONES, SHALES; sedimentary rocks that have changed very little
-  SEDIMENTARY ROCKS mixed with VOLCANIC IGNEOUS ROCKS; many changed by mountain-building and metamorphism

* WORLD'S OLDEST ROCKS — THE ACASTA GNEISS (almost 4 billion years old!)

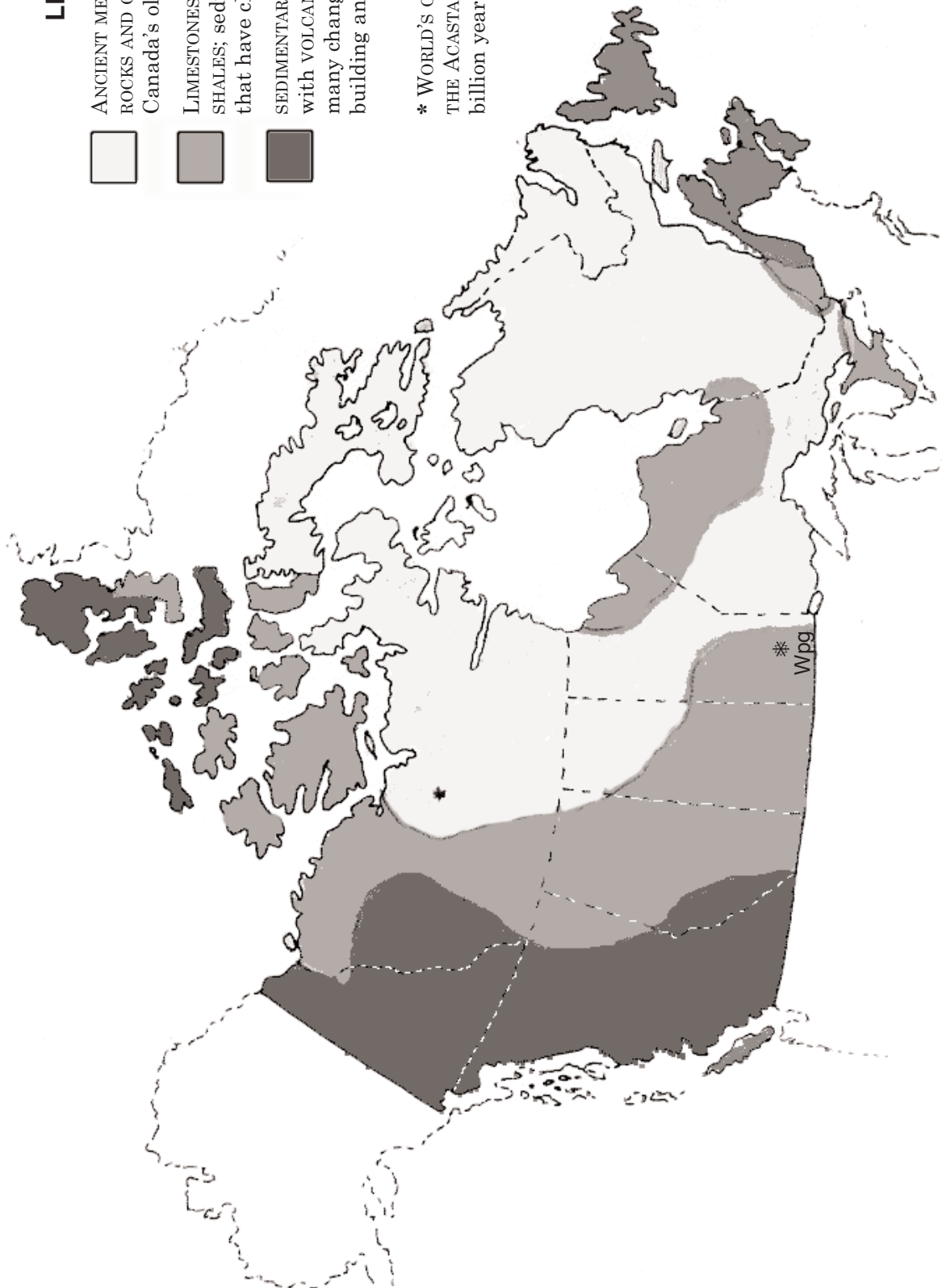

Geological Map of Canada: Student Version

LEGEND

1

ANCIENT METAMORPHIC
ROCKS AND GRANITE;
Canada's oldest surface.

2

LIMESTONES, SANDSTONES,
SHALES; SEDIMENTARY ROCKS
that have changed very little.

3

SEDIMENTARY ROCKS mixed
with VOLCANIC IGNEOUS ROCKS;
many changed by mountain-
building and metamorphism.

* WORLD'S OLDEST ROCKS —
THE ACASTA GNEISS (almost 4
billion years old!)

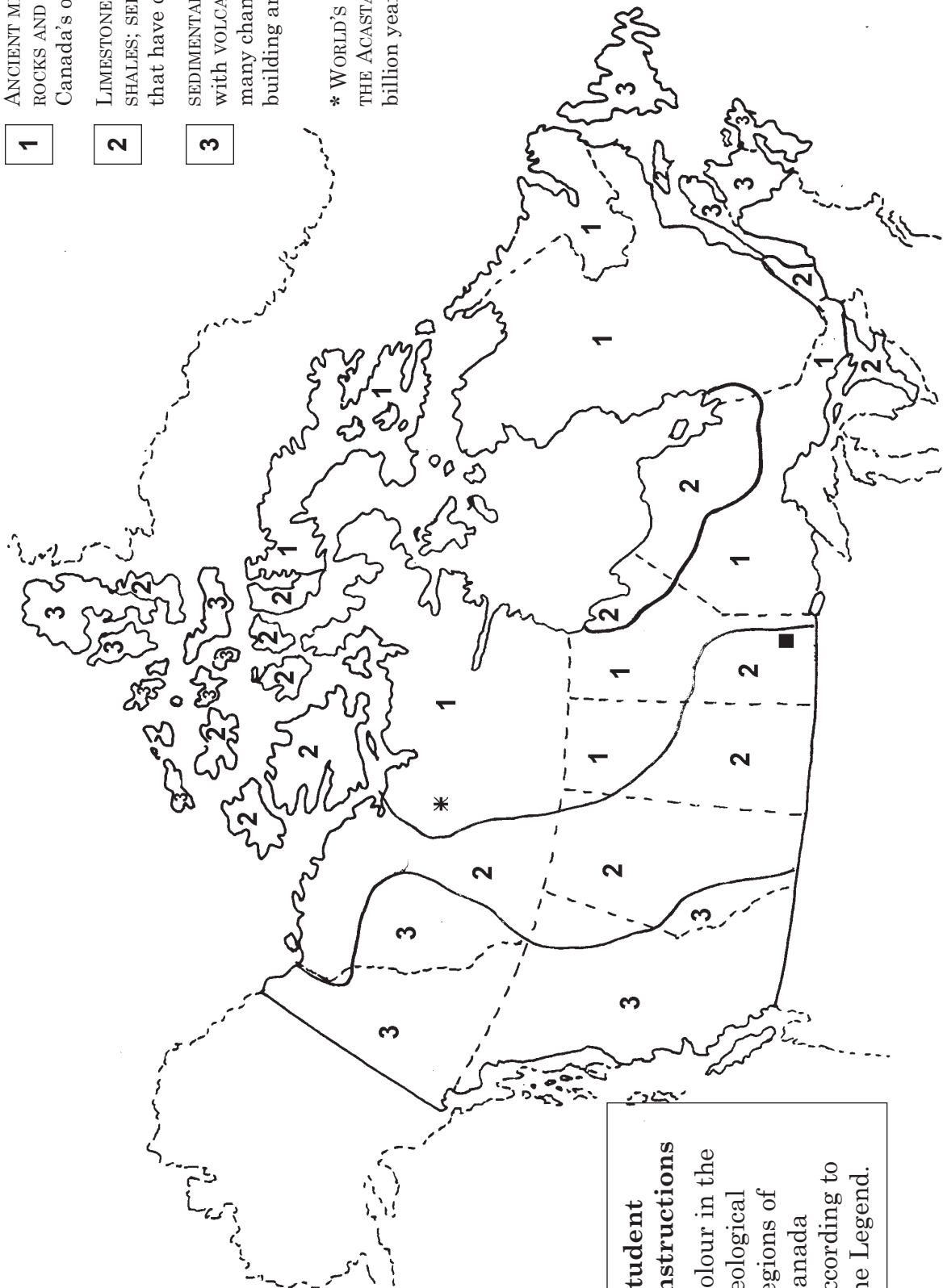

Student Instructions
Colour in the geological regions of Canada according to the Legend.

Geological Map of Manitoba

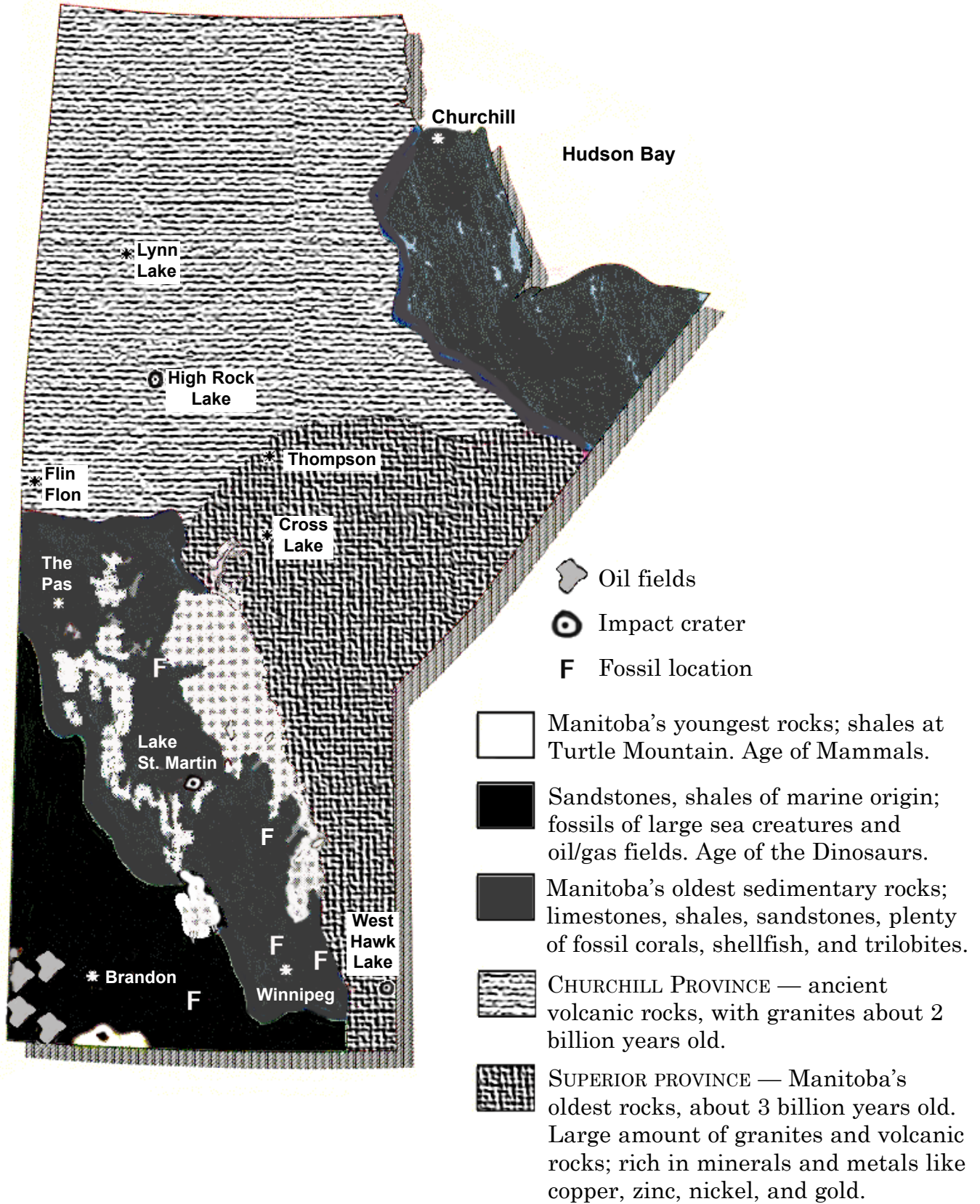

Geological Map of Manitoba: Student Version

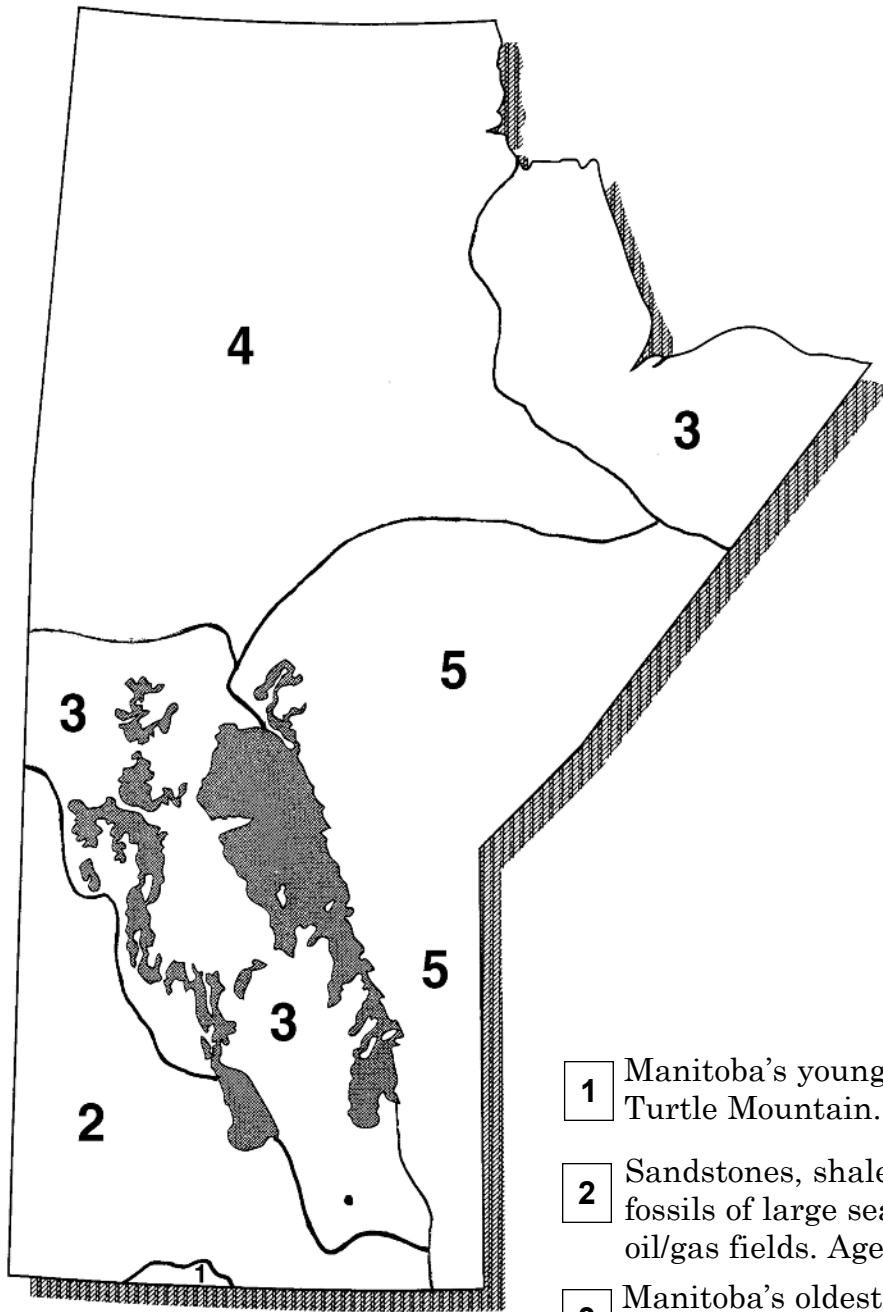

Student Instructions

Colour in the geological regions of Canada according to the Legend.

- 1 Manitoba's youngest rocks; shales at Turtle Mountain. Age of Mammals.
- 2 Sandstones, shales of marine origin; fossils of large sea creatures and oil/gas fields. Age of the Dinosaurs.
- 3 Manitoba's oldest sedimentary rocks; limestones, shales, sandstones, plenty of fossil corals, shellfish, and trilobites.
- 4 CHURCHILL PROVINCE — ancient volcanic rocks with granites about 2 billion years old.
- 5 SUPERIOR PROVINCE — Manitoba's oldest rocks, about 3 billion years old. Large amount of granites and volcanic rocks; rich in minerals and metals like copper, zinc, nickel, and gold.

