



GRADE 12 PHYSICS (40S)

Final Practice Examination

GRADE 12 PHYSICS (40S)

Final Practice Examination

Instructions

The final examination will be weighted as follows

Modules 1–10 100%

The format of the examination will be as follows:

Part A: Multiple Choice 24 x 1 = 24 marks

Part B: Fill-in-the-Blanks 14 x 0.5 = 7 marks

Part C: Short Explanation Questions 5 x 4 = 20 marks

Part D: Problems 7 x 7 = 49 marks

**Grade 12 Physics
Final Practice Examination**

Part A: Multiple Choice

Write the letter of the choice that best completes each statement.

| | | | | | | | | | |
|-----|--|--|-----|--|--|-----|--|--|--|
| 1. | | | 11. | | | 21. | | | |
| 2. | | | 12. | | | 22. | | | |
| 3. | | | 13. | | | 23. | | | |
| 4. | | | 14. | | | 24. | | | |
| 5. | | | 15. | | | | | | |
| 6. | | | 16. | | | | | | |
| 7. | | | 17. | | | | | | |
| 8. | | | 18. | | | | | | |
| 9. | | | 19. | | | | | | |
| 10. | | | 20. | | | | | | |

Part B: Fill-in-the-Blanks

Write the word that best completes each statement in the space provided below.

| | | | | |
|----|--|--|-----|--|
| 1. | | | 8. | |
| 2. | | | 9. | |
| 3. | | | 10. | |
| 4. | | | 11. | |
| 5. | | | 12. | |
| 6. | | | 13. | |
| 7. | | | 14. | |

Part A: Multiple Choice (24 x 1 = 21 Marks)

Enter the letter of the choice that best answers the question on the answer sheet provided. Please print the letters of your answers clearly.

1. One of the hazards associated with travelling in space is the
 - a) extreme heat of deep space
 - b) extreme atmospheric pressure of deep space
 - c) very low energy of ionizing cosmic radiation
 - d) possible damage to hormonal and immune systems

2. According to Kepler, planets move in
 - a) circular orbits with the sun at the centre
 - b) elliptical orbits with the sun at the centre
 - c) elliptical orbits with the sun at one of the foci
 - d) elliptical orbits with the sun at both foci

3. In Kepler's law, Kepler's constant K is
 - a) greater when the mass is closest to the central body in its orbit
 - b) a constant for any mass orbiting any central body
 - c) a constant but lesser value for a satellite orbiting a less massive central body
 - d) a constant but greater value for a mass orbiting a less massive central body

4. As a rocket moves farther and farther away from earth,
 - a) the universal gravitational constant, G , decreases in value, and the gravitational field constant, \bar{g} , also decreases in value
 - b) the universal gravitational constant, G , remains constant in value, and the gravitational field constant, \bar{g} , decreases in value
 - c) the universal gravitational constant, G , remains constant in value, and the gravitational field constant, \bar{g} , also remains constant in value
 - d) the universal gravitational constant, G , increases in value, and the gravitational field constant, \bar{g} , also increases in value

5. In a geosynchronous orbit, the satellite
- a) has a radius of orbit that is one-half the radius of orbit of the moon
 - b) has a radius of orbit that is equivalent to the radius of earth itself
 - c) has a period of orbit equivalent to one earth day
 - d) has a period of orbit that is of the same length as one orbit of the moon around earth
6. The “Hohmann transfer” is used to allow a vehicle to
- a) pass safely through earth’s atmosphere upon re-entry
 - b) launch a vehicle from earth’s surface into orbit
 - c) pass from one radius of orbit to another
 - d) launch a vehicle from earth’s surface into deep space
7. A proton is located at distance r to the left of an electron. The proton is then moved around the electron in a circle with a constant radius r . The force on the proton is
- a) greater in magnitude than the force on the electron and away from the electron
 - b) greater in magnitude than the force on the electron and towards the electron
 - c) the same in magnitude as the force on the electron and away from the electron
 - d) the same in magnitude as the force on the electron and towards the electron
8. In comparing the gravitational force and the electric force, both forces
- a) are always attractive and can never be repulsive
 - b) are inversely proportional to the separation between the masses or charges to the first power
 - c) are directly proportional to the product of the masses or the charges
 - d) increase in magnitude and the distance between the masses or charges increases

9. In a parallel plate apparatus, the plates are 5.00 mm apart. A potential difference of 300.0 V exists between the plates.

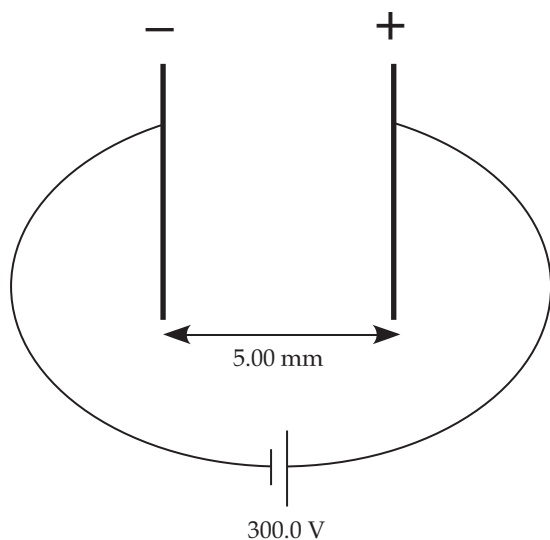

The electric field strength between the plates is

- a) 1.50 V/m
 - b) 1.00×10^2 V/m
 - c) 1.50×10^3 V/m
 - d) 6.00×10^4 V/m
10. A beam of electrons is moving towards the west. The beam, which is about to enter a magnetic field, is directed "into the page."

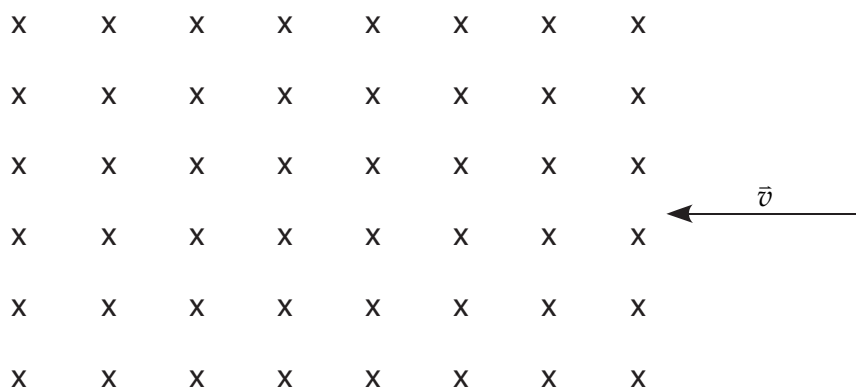

The direction of the magnetic force on the electrons is

- a) in the same direction as the magnetic field into the page
- b) opposite the direction of the magnetic field, out of the page
- c) upwards (north)
- d) downwards (south)

11. In a mass spectrograph, a charged particle, q , passes through a velocity selector whose electric field is E and of magnetic field strength B_1 . It then passes into a magnetic field B_2 where it follows a curved path of radius R . The mass of the charged particle is
- a) $m = \frac{BB'R}{qE}$
 - b) $m = \frac{qE}{BB'R}$
 - c) $m = \frac{E}{qBB'R}$
 - d) $m = \frac{qBB'R}{E}$
12. If a current of 0.15 mA flows through a pocket calculator for 5.0 minutes, then the amount of charge delivered to the calculator is
- a) 0.045 C
 - b) 0.000 75 C
 - c) 45 C
 - d) 0.75 C
13. In general, we can say that the resistance in a current-carrying wire increases when
- a) the length decreases and the cross-sectional area decreases
 - b) the length increases and the cross-sectional area decreases
 - c) the length decreases and the cross-sectional area increases
 - d) the length increases and the cross-sectional area increases
14. There are two resistors, R_1 and R_2 , connected in parallel to a power source. To measure the current passing through the resistor R_1 ,
- a) a voltmeter should be connected in parallel with R_1
 - b) an ammeter should be connected in parallel with R_1
 - c) a voltmeter should be connected in series with R_1
 - d) an ammeter should be connected in series with R_1

15. Based on experiments showing the relationship between current and resistance under conditions of constant voltage, the graph that shows this relationship is

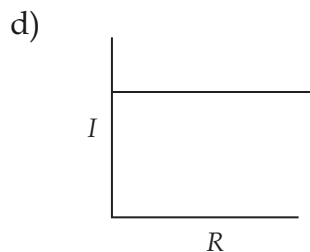
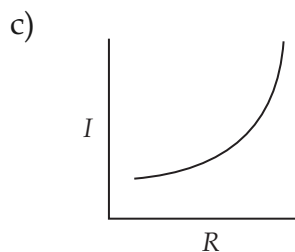
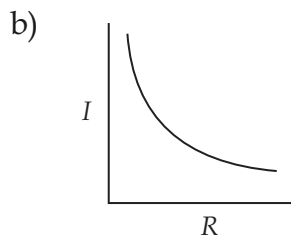
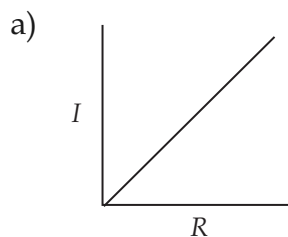

16. The diagram below shows the south pole of a magnet moving towards a coil of wire generating a current that is measured by the galvanometer. To achieve this same effect, one could

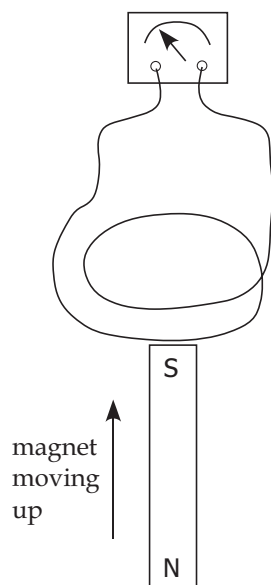

- hold the magnet stationary and move the coil up
- move the south pole of the magnet downwards away from the stationary coil
- rotate the magnet so that the north pole faces the coil and moves downwards
- hold the coil and the magnet stationary but use a "stronger" magnet

17. A magnetic field of 0.10 T is directed downwards at 90.0° to a coil of wire with 10 turns. The coil has a radius of 0.39 m. The magnetic field is then removed in a time of 0.20 s. An external resistor is attached to the loop.

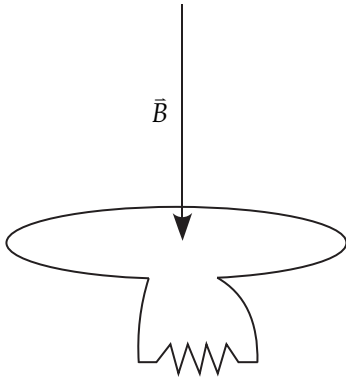

If more turns of wire are added to the loop, then that factor they would increase would be the

- a) resistance of the external resistor
 - b) strength of the magnetic field
 - c) size of the area of the coil
 - d) magnitude of the induced current
18. An armature had 50 turns of wire and a cross-sectional area of 0.0200 m^2 . The armature is rotating at a frequency of 30.0 Hz to produce a peak EMF of 6.00 V. The magnetic field must be
- a) 0.0318 T
 - b) 0.0637 T
 - c) 0.200 T
 - d) 31.4 T

19. One of the isotopes of gold contains 79 protons and 118 neutrons. For this isotope, the
- atomic number is 79 and the mass number is 118
 - atomic number is 79 and the mass number is 39
 - atomic number is 79 and the mass number is 197
 - atomic number is 197 and the mass number is 79
20. The strong nuclear force acts between
- the nucleus and the electrons to keep the atom together
 - all particles in the nucleus to keep the nucleus together
 - the protons only in a nucleus to keep the nucleus together
 - the neutrons only in a nucleus to keep the nucleus together
21. The equation showing the β^- decay of ${}^{35}_{16}\text{S}$ is
- ${}^{35}_{16}\text{S} \rightarrow {}^{35}_{17}\text{Cl} + {}^0_{-1}e + \bar{\nu}$
 - ${}^{35}_{16}\text{S} \rightarrow {}^{35}_{15}\text{P} + {}^0_1e + \bar{\nu}$
 - ${}^{35}_{16}\text{S} \rightarrow {}^{35}_{15}\text{P} + {}^0_{-1}e + \bar{\nu}$
 - ${}^{35}_{16}\text{S} \rightarrow {}^{35}_{16}\text{S} + {}^0_{-1}e + \bar{\nu}$
22. A 1000 Bq source of ${}^{24}_{11}\text{Na}$ with a half-life of 15 h is placed in a container where its activity can be measured. How much time passes before the activity becomes 125 Bq?
- 45 h
 - 60 h
 - 90 h
 - 120 h
23. An example of ionizing radiation is
- radio waves
 - neutrons at rest
 - gamma waves
 - an α particle at rest

24. The technique that makes use of collimated X-rays, detectors, and computer analysis to produce images of slices through the body is called
- a) MRI
 - b) endoscopy
 - c) CAT
 - d) photodynamic therapy

Part B: Fill-in-the-Blanks (14 x 0.5 = 7 Marks)

Fill in the blanks with one of the choices in the word bank. The terms in the word bank may be used once, more than once, or not at all.

Write your answers in the space provided on the answer sheet.

| | | | |
|---------------|---------------------|------------------------------|------------|
| armature | current | positron emission tomography | ultrasound |
| atomic number | gamma knife surgery | radiocarbon dating | voltage |
| Becquerel | induced | radio waves | volts |
| binding | kinetic | resistance | weight |
| brushes | mass number | Rutherford | |
| Coulomb | Newton | transmutation | |

1. A technique that allows a two-dimensional image to be taken of the body to learn about the metabolism and function of an organ is called _____. (Outcome S4P-4-9)
2. A medical technique that involves irradiating cancer cells with a highly focused beam directed through holes in a helmet is called _____. (Outcome S4P-4-9)
3. An example of non-ionizing radiation is _____. (Outcome S4P-4-5)
4. The age of a sample of material from once-living organisms can be determined using a process called _____. (Outcome S4P-4-3)
5. The unit for the activity of a radioactive isotope is the _____. (Outcome S4P-4-2)
6. The process of the atom of one element changing into an atom of another element is called _____. (Outcome S4P-4-4)
7. The number of protons in an atom gives the _____ of that atom. (Outcome S4P-4-1)
8. The part of a generator that consists of a coil wound around an iron core is the _____. (Outcome S4P-3-11)
9. The current that is produced by a rod moving through the magnetic field is called a(n) _____ current. (Outcome S4P-3-8)
10. Two resistors are connected in parallel. In this case, which of voltage, current, or resistance will be the same for both resistors? _____ (Outcome S4P-3-6)

11. The scientist who determined the relationship governing the electrostatic forces between point charges was _____ . (Outcome S4P-2-14)
12. Electric potential has units of _____ . (Outcome S4P-2-18)
13. The amount of energy required to lift a satellite resting on the surface of the earth out to infinity is called the _____ . energy. (Outcome S4P-2-5)
14. The force of gravity acting on an object is also known as _____ . (Outcome S4P-2-6)

Part C: Short Explanation Questions (5 x 4 = 20 Marks)

Answer any four (5) of the following questions. Be sure to indicate clearly which five questions are to be marked. Use proper English in your explanations.

Outcome S4P-2-1

1. Identify and briefly explain two advantages and two disadvantages of the following issue: Humans should continue to explore space.

Outcome S4P-2-2

2. State Kepler's three laws of planetary motion.

Outcome S4P-2-17, S4P-2-18, S4P-2-16

3. State the meaning of the following terms: electric potential energy, electric field, and electric potential. Give the units of each and state whether each is a vector or scalar.

Outcome S4P-2-21

4. Describe how the right-hand rule (flat hand) relates the directions of the magnetic field, the velocity, and the magnetic force.

Outcome S4P-3-2

5. Briefly describe how **only one** of the following added to the scientific knowledge about current electricity by building on the work of those who had come before them.

a) Georg Simon Ohm

b) James Prescott Joule

c) Gustav Robert Kirchoff

Outcome S4P-3-13

6. Describe the operation of a transformer.

Outcome S4P-3-8

7. Describe the three ways by which an induced emf and an induced current are produced in a coil of wire.

Outcome S4P-4-1

8. Describe the nuclear model of the atom. Include the subatomic particles (protons, neutrons, and electrons), their locations, and the forces that hold the particles together.

Outcome S4P-4-4

9. Describe alpha radiation, beta radiation, and gamma radiation. Include in your description how each type of radiation is produced and how the parent nucleus is changed by the emission of this type of radiation.

Part D: Problems (7 x 7 = 49 Marks)

Answer any seven (7) problems. Please show your work. Number your answers clearly.

Outcomes S4P-2-2, S4P-2-3, S4P-2-8

1. Mars orbits the sun with a mean radius of orbit of 2.28×10^{11} m and a period of 5.94×10^7 seconds. The universal gravitational constant is $6.67 \times 10^{-11} \text{ N} \cdot \text{m}^2/\text{kg}^2$.
 - a) Calculate the speed of Mars as it orbits the sun.

b) Calculate K for the sun.

c) Calculate the mass of the sun.

Outcome S4P-2-4, S4P-2-5, S4P-2-6

2. A spacecraft of mass 1240 kg orbits the earth with a radius of orbit of 7.05×10^7 m. The earth has a radius of 6.38×10^6 m and a mass of 5.98×10^{24} kg. The value of the universal constant, G , is $6.67 \times 10^{-11} \text{ N} \cdot \text{m}^2/\text{kg}^2$.

a) What is the gravitational potential energy of the orbiting spacecraft?

b) What is the binding energy of the spacecraft?

c) What is the gravitational field at the position that the spacecraft is located?

Outcome S4P-2-14

3. In the diagram below, $q_1 = +4.50 \times 10^{-6} \text{ C}$, $q_2 = -3.25 \times 10^{-6} \text{ C}$ and $q_3 = +3.73 \times 10^{-6} \text{ C}$. Charges 1 and 2 are separated by 3.00 cm and charges 1 and 3 are separated by 1.50 cm. The constant in Coulomb's Law, k , is $8.99 \times 10^9 \text{ N} \cdot \text{m}^2/\text{C}^2$.

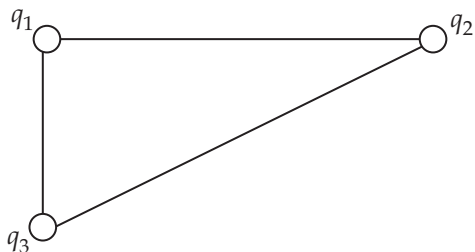

- a) Determine the electric force acting on q_1 .

b) Determine the electric field at q_1 .

Outcome S4P-2-20, S4P-2-15

4. An electron of mass 9.11×10^{-31} kg is at rest on the negative plate of a parallel plate capacitor. The electron is repelled by the negative plate and attracted to the positive plate by a force of 6.45×10^{-16} N. The distance between the plates is 2.50 mm. The charge on 1 electron is -1.60×10^{-19} C.

a) Sketch the electric field between the plates of the charged parallel plate capacitor.

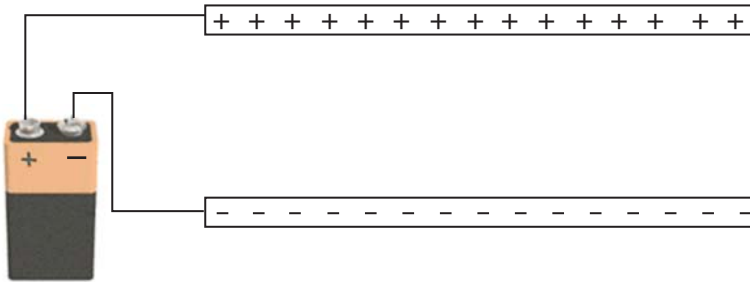

b) Calculate the electric field between the plates of the charged parallel plate capacitor.

c) What is the velocity of the electron just before it crashes into the positive plate?

Outcome S4P-3-3, S4P-3-5, S4P-3-6

5. A high-voltage transmission line has a distance of 185 m between its towers. The wires are made of aluminum, which has a resistivity of $2.82 \times 10^{-8} \Omega \cdot \text{m}$. The wires are made of strands of aluminum braided together. Each strand has a diameter of $1.20 \times 10^{-3} \text{ m}$ and there are 235 strands in each wire.

a) What is the area of one strand of wire?

b) What is the resistance of each strand?

c) What is the total resistance of one of the braided wires between two towers, assuming the strands of wire are connected in parallel?

d) If the voltage drop along the line between the two towers is 88.8 volts, what is the current in a braided wire?

Outcome S4P-3-6

6. A 1600-watt iron is connected to a 120 volt line and is operated for 2.75 hours.
- Calculate the current drawn by the iron.

b) What is the resistance of the iron?

c) Calculate the charge, in coulombs, that flowed through the iron during the 2.75 hours.

d) What is the maximum wattage that can be used for an iron if the breaker for this circuit is rated at 20.0 amperes?

Outcome S4P-3-5, S4P-3-6

7. Two $60\ \Omega$ resistors are connected in parallel. This parallel arrangement is connected in series with a $30\ \Omega$ resistor. The combination is then placed across a $120\ \text{V}$ potential difference. A circuit diagram is drawn below.

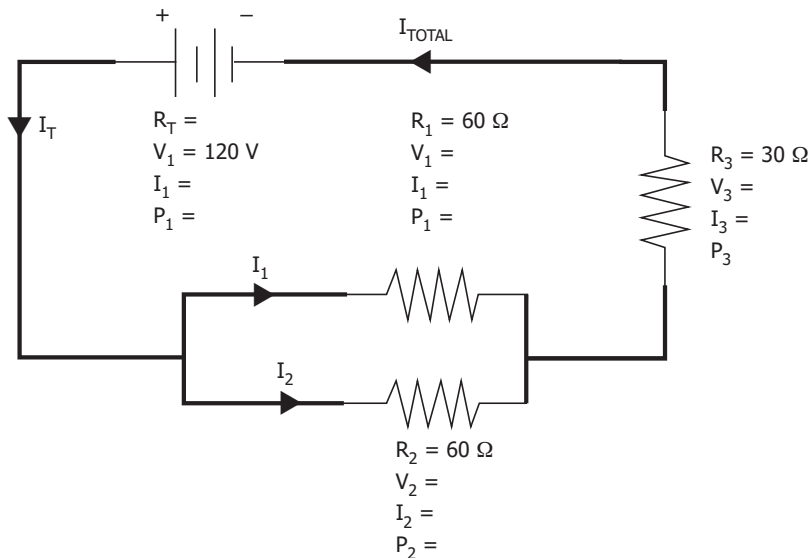

- a) What is the equivalent resistance of the parallel portion of the circuit?

b) What single resistance could replace the three original resistors?

c) What is the current in the circuit?

d) What is the potential drop across the $30\ \Omega$ resistor?

e) What is the voltage drop across the parallel portion of the circuit?

- f) Using the proper symbol for an ammeter, show one possible location for the ammeter to measure the current through the $30\ \Omega$ resistor.

c) Find the electrical power delivered to the bulb.

d) Find the energy used by the bulb in 45.0 s.

e) Describe the direction of flow of conventional current.

Outcome S4P-3-9, S4P-3-10

9. A coil of wire consists of 20 turns, each of which has an area of $1.50 \times 10^{-2} \text{ m}^2$. A magnetic field is perpendicular to the surface at all times. At a time t_0 , the magnitude of the magnetic field at the location of the coil is $B_0 = 0.0500 \text{ T}$. At a later time $t = 0.100 \text{ s}$, the magnitude of the field at the coil has increased to $B = 0.0600 \text{ T}$. The magnetic field originates to the left of a coil and is therefore directed to the right towards the coil. The points B and C are closer to you than the point A.

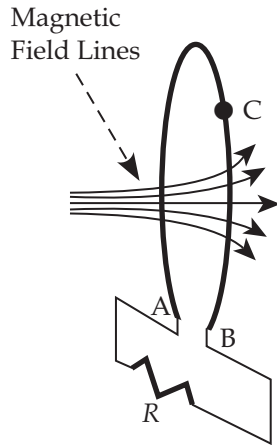

- a) Find the average emf induced in the coil during this time.

- b) In what direction is the induced magnetic field?
- c) Using the letters A, B, and C, give the direction of flow of the induced current?
- d) Label the polarity of points A and B.
- e) What would be the average induced emf if the magnitude of the magnetic field decreased from 0.0600 T to 0.0500 T in 0.100 s?

Outcome S4P-4-2, S4P-4-4

Some of the following masses are required to solve the problem.

| Isotope | Mass in atomic mass units (u) |
|--------------------------|-------------------------------|
| ${}^4_2\text{He}$ | 4.002 602 u |
| ${}^{14}_6\text{C}$ | 14.003 241 u |
| ${}^{14}_7\text{N}$ | 14.003 074 u |
| ${}^{22}_{10}\text{Ne}$ | 21.991 383 u |
| ${}^{22}_{11}\text{Na}$ | 21.994 434 u |
| ${}^{228}_{90}\text{Th}$ | 228.028 716 u |
| ${}^{232}_{92}\text{U}$ | 232.037 131 u |

10. One of the ways in which the element neon can be formed is through the beta positive decay of ${}^{23}_{11}\text{Na}$. The speed of light is 3.00×10^8 m/s and $1 \text{ u} = 1.660 56 \times 10^{-27}$ kg.
- a) Write an equation for this decay.
- b) If the mass defect is 5.06637×10^{-30} kg, determine the energy released in units of joules.
- c) The half-life of ${}^{22}_{11}\text{Na}$ is 2.60 years. If 25.0 grams of ${}^{22}_{11}\text{Na}$ is given to you today, after how many years would you have 0.391 grams remaining?

NOTES