



GRADE 11 PHYSICS (30S)

Final Practice Exam

Answer Key

GRADE 11 PHYSICS (30S)

Final Practice Exam Answer Key

Instructions

The final exam will be weighted as follows:

Modules 1–6	15–20%
Modules 7–10	80–85%

The format of the examination will be as follows:

Part A: Multiple Choice	40 x 1 = 40 marks
Part B: Short Explanations	5 x 3 = 15 marks
Part C: Diagrams	15 marks
Part D: Problems	1 x 6 = 6 marks
Part E: Problems	4 x 6 = 24 marks

The following instructions are meant to assist you when you are writing your final examination.

- Show your work for the problems.
- Include directions with all vector answers.
- Round off answers to the correct number of significant digits.

Part A: Multiple Choice (40 x 1 = 40 Marks)

Circle the letter of the choice that best completes each statement.

1. Those two quantities that are vectors are
 - a) acceleration and electric charge
 - b) mass and gravitational field
 - c) force and velocity
 - d) speed and time interval

Answer (c)

Outcome S3P-3-01, S3P-4-19, S3P-4-01, S3P-4-03, S3P-4-04, S3P-3-03

2. An object moves to the right 10.0 m from the starting point in a time of 1.0 s, then to the left 20.0 m in a time of 3.0 s, and then to the right 5.0 m in a time of 1.0 s. The diagram below represents this motion.

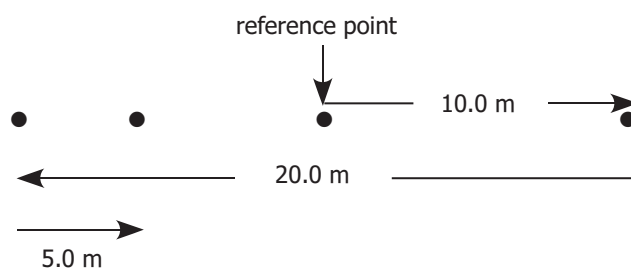

The average speed of the object over the whole time interval is best written as

- a) -1.2 m/s
- b) 0.8 m/s
- c) 1.2 m/s
- d) 7.0 m/s

Answer (d)

Outcome S3P-3-01

3. The graph below is a velocity-time graph for the motion of an object.

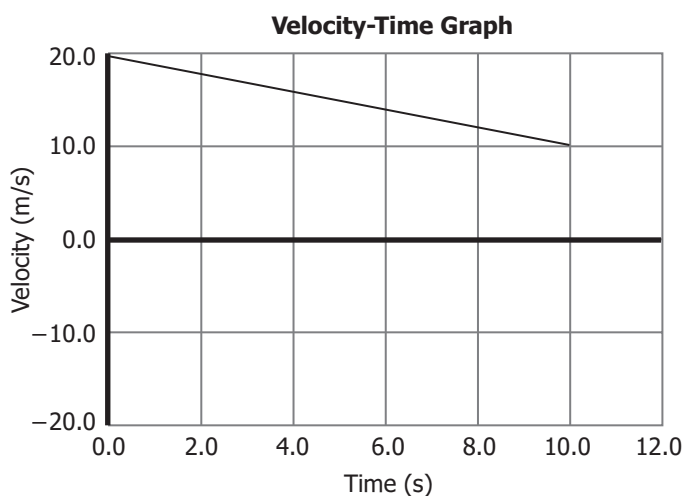

The acceleration of this object is

- a) -2.0 m/s^2
- b) -1.0 m/s^2
- c) $+1.0 \text{ m/s}^2$
- a) $+2.0 \text{ m/s}^2$

Answer (b)

Outcome S3P-3-04

4. If an object is already moving and the sum of all the vector forces on a mass is zero, then the object will
- a) move at a constant speed in a straight line
 - b) accelerate at a constant rate in a straight line
 - c) come to rest
 - d) increase its amount of inertia

Answer (a)

Outcome S3P-3-11

5. Two forces are acting on a 5.00 kg mass. One of the forces is 10.0 N south and the other is 15.0 N east. The magnitude of the acceleration of the mass is
- a) 3.60 m/s^2
 - b) 5.00 m/s^2
 - c) 18.0 m/s^2
 - d) 25.0 m/s^2

Answer (a)

Outcome S3P.3.11

6. The factors, both of which will increase the magnetic field strength of an electromagnet, are
- a) increased electrical current and fewer coils of wire
 - b) increased diameter of coil and an increase in the number of coils
 - c) an increase in the electrical current and using a strong ferromagnetic material like iron
 - d) using an air core instead of iron and increasing the diameter of the coil

Answer (c)

Outcome S3P-4-24

7. On Mars, the gravitational field strength is 3.7 N/kg . An object has a weight of 98 N on the earth. The weight of this object on Mars is
- a) $10. \text{ N}$
 - b) 37 N
 - c) 98 N
 - d) 363 N

Answer (b)

Outcome S3P-4-04

8. A 5.0 kg mass is placed in an elevator that is accelerating upwards at 4.0 m/s^2 . The apparent weight of this mass is
- a) $20. \text{ N}$
 - b) 29 N
 - c) 49 N
 - d) 69 N

Answer (d)

Outcome S3P-4-05

9. The diagram below shows a wave. The arrow is showing the distance from the top of the wave to the bottom of the wave.

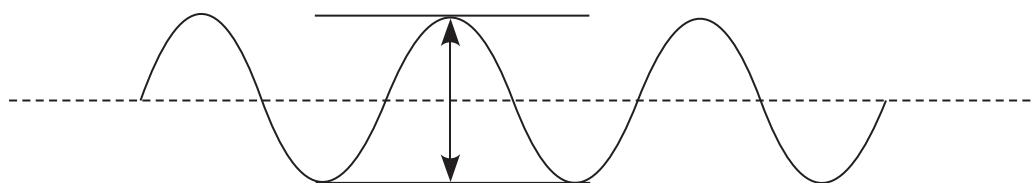

This arrow represents

- a) the amplitude
- b) twice the amplitude
- c) the wavelength
- d) twice the wavelength

Answer (b)

Outcome S3P-1-02

10. A 50.0 kg crate rests on the floor of a warehouse. The coefficient of static friction is 0.750 and the coefficient of kinetic friction is 0.450. We want to determine the horizontal force (to the right) required just to start the crate moving. The horizontal force (to the right) required to just get the crate moving along the floor is

- a) 22.5 N
- b) 37.5 N
- c) 221 N
- d) 368 N

Answer (d)

Outcome S3P-4-11, S3P-4-13

11. The magnetic field is

- a) strongest near a pole and the direction at any point in space is tangent to the field line
- b) strongest far from a pole and the direction at any point in space is tangent to the field line
- c) strongest near a pole and the direction at any point in space is perpendicular to the field line
- d) strongest far from a pole and the direction at any point in space is perpendicular to the field line

Answer (a)

Outcome S3P-4-17

12. A standing wave is formed by waves of frequency 256 Hz. The speed of the waves is 128 m/s. The distance between the nodes must be

- a) 2.00 m
- b) 1.00 m
- c) 0.500 m
- d) 0.250 m

Answer (d)

Outcome S3P-1-06

13. Consider the direction in which the magnetic field lines point for a bar magnet with a north pole and a south pole. That situation that would give the same pattern of lines is the

- a) gravitational field line pattern for two neutral masses
- b) electric field line pattern for two positive charges
- c) electric field line pattern for two negative charges
- d) electric field line pattern for two opposite charges

Answer (d)

Outcome S3P-4-17

14. When a wave moves from shallow water to deep water, the
- frequency decreases, the wavelength increases, and the speed increases
 - frequency does not change, the wavelength increases, and the speed increases
 - frequency does not change, the wavelength decreases, and the speed decreases
 - frequency does not change, the wavelength increases, and the speed decreases

Answer (b)

Outcome S3P-1-11

15. The definition of magnetic inclination is the angle between
- magnetic north and geographic north
 - magnetic north and geographic south
 - the earth's magnetic field at any point and the vertical
 - the earth's magnetic field at any point and the horizontal

Answer (d)

Outcome S3P.4.20

16. The following is a sound spectrum created by an instrument playing a certain note.

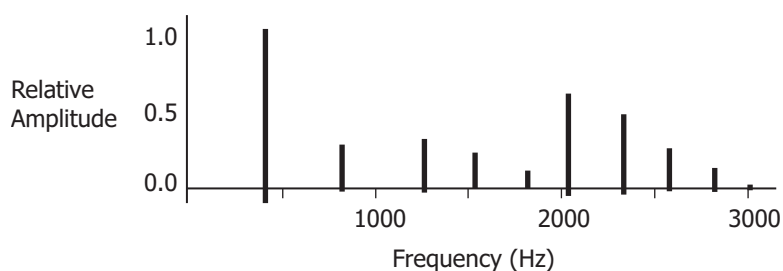

If another instrument were to play the same note, then

- the fundamental frequency would be the same, and the number and relative intensity of the harmonics would also be the same
- the fundamental frequency would be the same, but the number and relative intensity of the harmonics would be different
- the fundamental frequency would be different, but the number and relative intensity of the harmonics would also be the same
- the fundamental frequency would be different, and the number and relative intensity of the harmonics would also be different

Answer (b)

Outcome S3P-1-17, S3P-1-27

17. The diagram below shows an electrical current flowing through a straight conductor. The dark arrow shows the electrical current moving to the right. The symbol (I) will be used to represent the electric current.

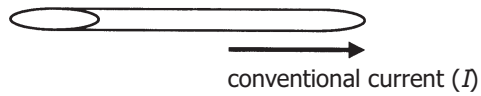

The symbol B will be used to represent the magnetic field. The diagram that shows the direction of the magnetic field produced by the current-carrying wire is

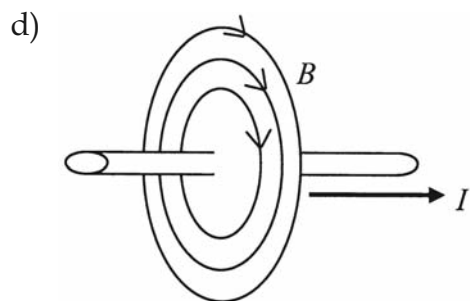
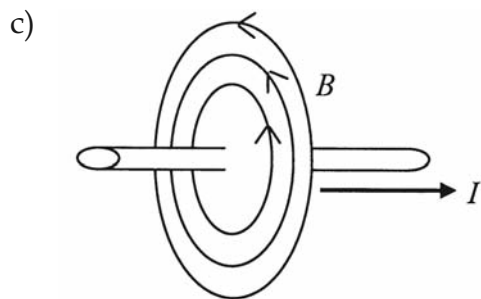
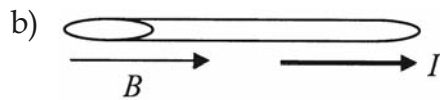
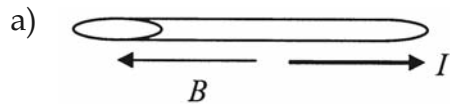

Answer (d)
Outcome S3P-4-22

18. A 15,000 Hz sound wave and a 5,000 Hz sound wave approach a small hole in a wall. The degree of “bending” as the waves move through the hole

- a) depends on the speed of the wave
- b) is the same for both waves
- c) is greater for the 5,000 Hz wave
- d) is greater for the 15,000 Hz wave

Answer (c)

Outcome S3P-1-14

19. The frequency of middle C is 256 Hz. The frequency of a C note two octaves below middle C is

- a) 64 Hz
- b) 128 Hz
- c) 252 Hz
- d) 254 Hz

Answer (a)

Outcome S3P-1-28

20. An air column that is solid at one end is used to determine the speed of sound. The frequency of an E note tuning fork is 329.6 Hz. The length of the shortest air column producing the resonance is 25.0 cm. The speed of the sound must be

- a) 20.6 m/s
- b) 82.4 m/s
- c) 330 m/s
- d) 33000 m/s

Answer (c)

Outcome S3P-1-22

21. A pulse on a spring is moving from the right to the left. There is a circle on the right edge of the pulse.



As the pulse moves to the left, the circle on the right edge of the pulse will move

- a) to the left
- b) to the right
- c) upwards
- d) downwards

Answer (d)

Outcome S3P-1-01

22. If the frequency of a "C" note in the musical scale is 262 Hz, then we can say that the
- a) period will be the inverse of the frequency and the speed of the wave will be changed
 - b) period will be the inverse of the frequency and the speed of the wave will be constant
 - c) period will be identical to the frequency and the speed of the wave will be changed
 - d) period will be identical to the frequency and the speed of the wave will be constant

Answer (b)

Outcome S3P-1-03

23. The diagram below shows a longitudinal wave.

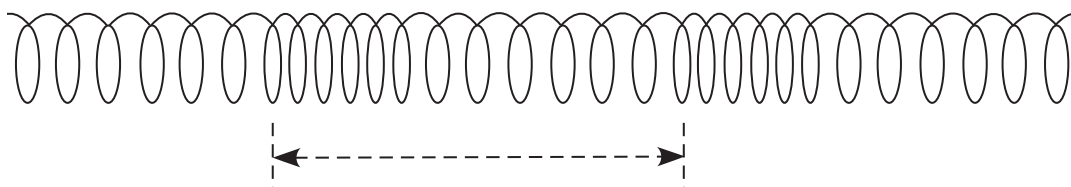

The horizontal distance indicated with the double arrow shows

- a) one wavelength
 - b) twice one wavelength
 - c) one amplitude
 - d) twice one amplitude
24. The two pulses shown below are about to pass through each other.

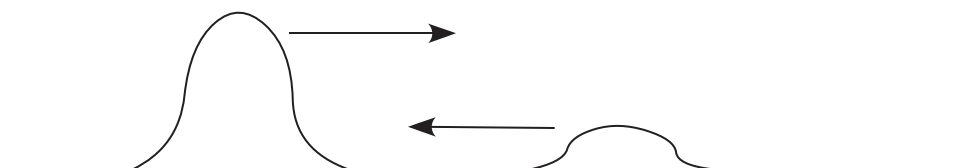

When the two pulses interfere with each other, the result is

- a) a standing wave pattern
- b) destructive interference
- c) constructive interference
- d) a constant nodal point

Answer (c)

Outcome S3P-1-06

25. A string is plucked producing four loops (antinodes). The length of the string is 12.00 m. The wavelength of the wave must be
- a) 48.0 m
 - b) 24.0 m
 - c) 6.0 m
 - d) 3.0 m

Answer (c)

Outcome S3P-1-06

26. A ripple tank is shown below.

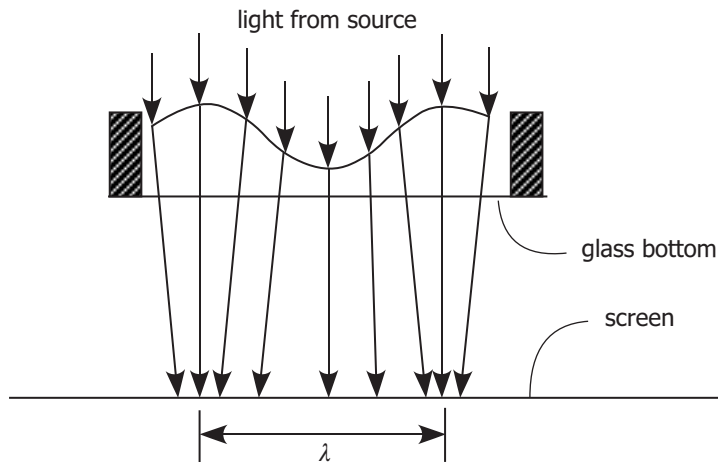

The double arrow at the bottom of the diagram indicates the distance between two

- a) dark spots and is equivalent to one-half a wavelength
- b) dark spots and is equivalent to one full wavelength
- c) bright spots and is equivalent to one-half a wavelength
- d) bright spots and is equivalent to one full wavelength

Answer (d)

Outcome S3P-1-08

27. The diagram below shows an incident wavefront approaching a straight barrier.



The diagram that shows the wave ray for the wavefront above is



Answer (c)

Outcome S3P-1-10

28. A wave travels at a speed of 10.0 cm/s in shallow water. The wavelength of the wave in the shallow water is 2.0 cm. The speed of the wave in the deep water is 12.0 cm/s. The wavelength of the wave in deep water is

- a) 0.42 cm
- b) 0.60 cm
- c) 1.7 cm
- d) 2.4 cm

Answer (d)

Outcome S3P-1-11, S3P-1-12, S3P-1-13

29. The diagram below shows waves moving from shallow water to deep water.

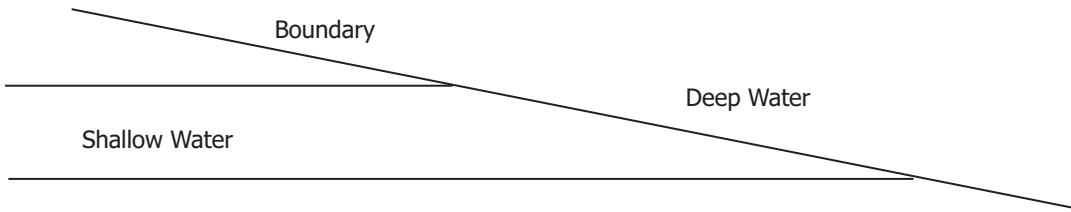

For each of the diagrams below, the dashed line represents a normal and the arrow represents the incident wave ray. The diagram showing the correct incident wave ray and angle of incidence for the incident wave ray is

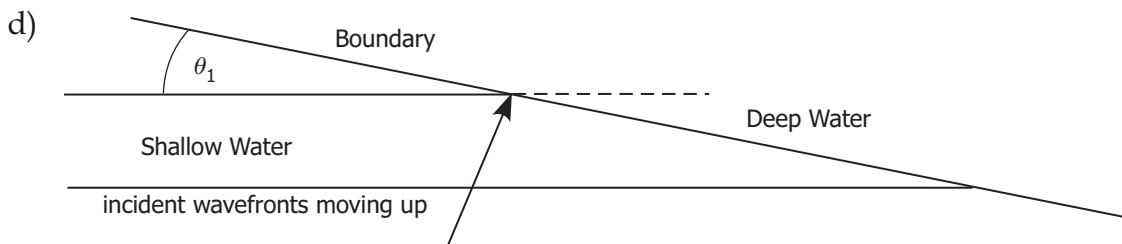
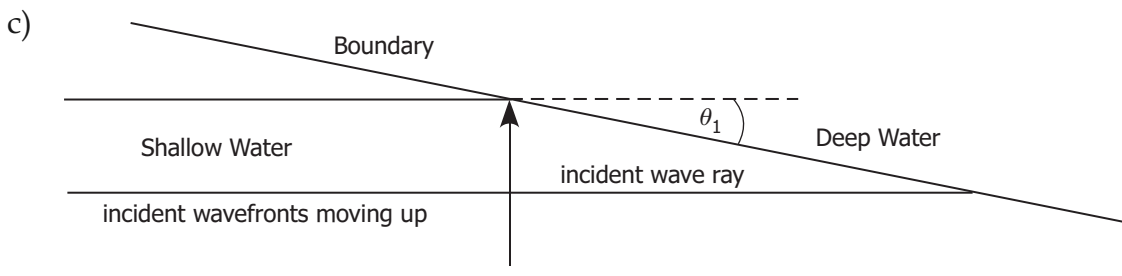
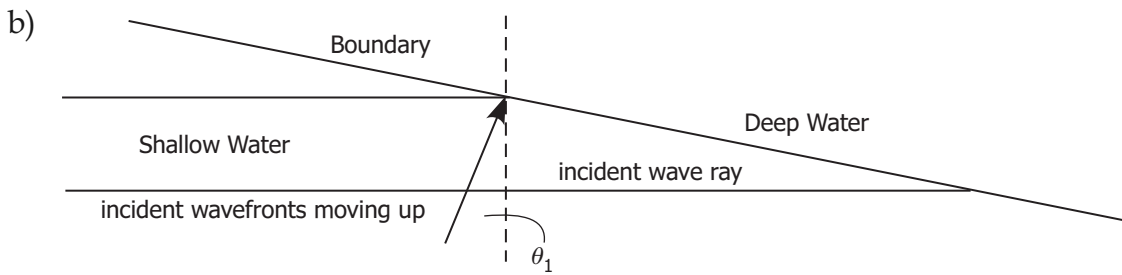
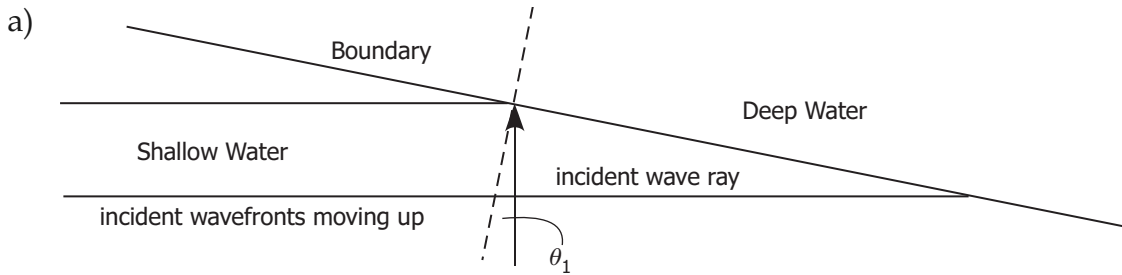

Answer (a)
Outcome S3P-1-11

30. In the diagram below, the point P is found on the nodal line as shown below in the square. The distance PS_1 is 10.0 cm and the distance PS_2 is 13.0 cm. The distance between the sources is 8.0 cm.

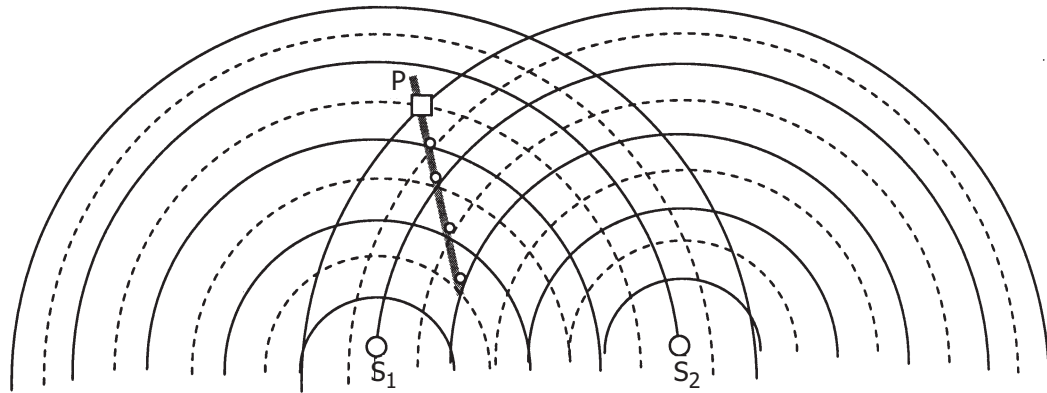

The wavelength of the waves producing the interference pattern must be

- a) 0.12 cm
 b) 2.0 cm
 c) 3.0 cm
 d) 6.0 cm
- Answer (b)**
 Outcome S3P-1-16
31. In a sound wave that moves to the right, a vibrating tuning fork creates a rarefaction when the fork moves
- a) to the right, creating a momentary fall in air pressure
 b) to the left, creating a momentary fall in air pressure
 c) to the right, creating a momentary rise in air pressure
 d) to the left, creating a momentary rise in air pressure
- Answer (b)**
 Outcome S3P-1-17
32. The sound level in a room may be 50. A sound that is twice as loud as a 50 sound is
- a) 60
 b) 100
 c) 500
 d) 5000
- Answer (a)**
 Outcome S3P-1-25

33. If the frequency of one source of sound is 500 Hz and a second sound source is 504 Hz, then when the two waves interfere with each other, the beat frequency will be
- a) 2 Hz
 - b) 4 Hz
 - c) 8 Hz
 - d) 16 Hz

Answer (b)

Outcome S3P-1-20

34. For a tube closed at one end, the length of the tube at a frequency of 256 Hz will be
- a) one-quarter the value for a tube open at both ends
 - b) one-half the value for a tube open at both ends
 - c) twice the value for a tube open at both ends
 - d) four times the value for a tube open at both ends

Answer (b)

Outcome S3P-1-20

35. The frequency of a G note is 384 Hz. Using the table below, the frequency of the B note must be

C	D	E	F	G	A	B	C'	D'
4	...	5	...	6				
			4	...	5	...	6	
				4	...	5	...	6

- a) 192 Hz
- b) 307 Hz
- c) 480 Hz
- d) 768 Hz

Answer (c)

Outcome S3P-1-28

36. A good scientific theory is one which is
- a) simple (less complex), has a wide scope, and is accurate and consistent
 - b) simple (less complex), narrow in scope, and is accurate and consistent
 - c) more complex, has a wide scope, is accurate and consistent
 - d) more complex, narrow in scope, consistent but not accurate

Answer (a)

Outcome S3P-2-05

37. When we perform an experiment and form a mental picture without necessarily having a mathematical relationship, this way of representing the experiment can be described as
- a) visual
 - b) symbolic
 - c) numeric
 - d) graphical

Answer (a)

Outcome S3P-2-02

38. Those who proposed the idea that light has wave-like properties were
- a) Huygens and Newton
 - b) Huygens and Planck
 - c) Maxwell and Planck
 - d) Maxwell and Huygens

Answer (d)

Outcome S3P-2-06

39. At the time of Newton, many scientists tried to produce wave interference effects, but were not successful. The reason for this is that
- a) incandescent light sources are out of phase and the wavelength of light is very large
 - b) incandescent light sources are out of phase and the wavelength is very small
 - c) incandescent light sources are in phase and the wavelength of light is very large
 - d) incandescent light sources are in phase and the wavelength of light is very small

Answer (b)

Outcome S3P-2-14

40. If light moves from left to right along the x -axis, then the electric field line vibrates along
- a) the x -axis and the magnetic field also vibrates along the x -axis
 - b) the x -axis and the magnetic field vibrates along the y -axis
 - c) the y -axis and the magnetic field vibrates along the x -axis
 - d) the y -axis and the magnetic field line vibrates along the z -axis

Answer (d)

Outcome S3P-2-15

Part B: Short Explanations (5 x 3 = 15 Marks)

Answer any five (5) of the following questions. Be sure to indicate clearly which five questions are to be marked.

Outcome S3P-1-01

1. Distinguish between transverse waves and longitudinal waves.

Answer:

Transverse waves are waves in which the direction of motion of the medium is perpendicular to the direction of motion of the disturbance. In longitudinal waves, the direction of motion of the medium is parallel to the direction of motion of the disturbance.

Outcome S3P-4-23

2. Using the Domain Theory of Magnetism, explain the following.
 - a) When placed in a strong magnetic field, a bar of iron becomes a bar magnet. When the field is removed, the piece of iron is no longer a bar magnet.

Answer:

When the bar of iron is placed in a strong magnetic field, the magnetic domains within the piece of iron align themselves with the magnetic field. The bar of iron then acts like a bar magnet. When the magnetic field is removed, the magnetic domains return to their original random arrangement. The piece of iron is no longer a bar magnet.

- b) Over a period of years, the steel girders in a building become magnetized.

Answer:

Over a period of years, the magnetic domains within the steel girders align themselves with the Earth's magnetic field, thus becoming magnetized.

Outcome S3P-1-21

3. Distinguish among fundamental frequency, overtone, and harmonic for a string of a guitar.

Answer:

The fundamental frequency of the guitar string is the lowest frequency at which the guitar string can vibrate (for example, 100 Hz).

An overtone is a frequency, which is a whole number multiple of the fundamental frequency. The first overtone has the frequency of twice the fundamental frequency (200 Hz).

A harmonic is a frequency, which is also a whole number multiple of the fundamental frequency. The first harmonic has a frequency equal to the fundamental frequency (100 Hz).

Outcome S3P-2-07

4. Using a diagram, explain how Newton's Corpuscular Theory explained refraction.

Answer:

Newton used two level surfaces, one slightly higher than the other, with a ramp joining the higher surface to the lower surface. As a particle rolled across the upper surface, it travelled in a straight-line path like light does in a uniform medium. When the particle reached around, it received a pull from gravity, changing the direction of its path. This change in direction corresponded to refraction. On the lower level, the particle again travelled in a straight line.

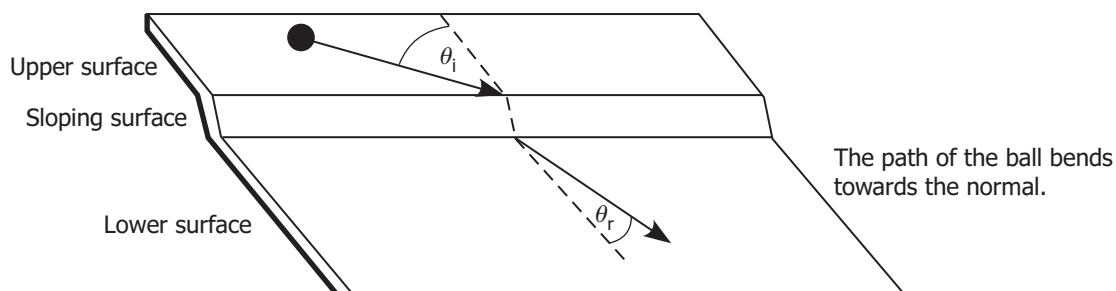

Outcome S3P-1-27

5. Distinguish between the pitch, the intensity, and the quality of sound produced by a musical instrument.

Answer:

Pitch refers to the frequency of the sound. A sound with a high frequency has a high pitch.

Intensity of sound refers to the energy carried by the sound and is most closely linked to the amplitude of the sound waves.

The quality of the sound refers to the complexity of the sound wave. The more complex the sound wave, the better the quality of the sound.

Outcome S3P-1-05

6. A wave crest is travelling along a heavy medium. The wave crest encounters a junction between the heavy medium and a light medium. Using a sketch, describe the situation after the wave crest has passed through the junction.

Here is a diagram of the situation before the crest hits the junction.



Answer:

The diagram below is how the medium would appear a short while after the incident pulse has hit the boundary. The reflected pulse and the transmitted pulses are both shown.

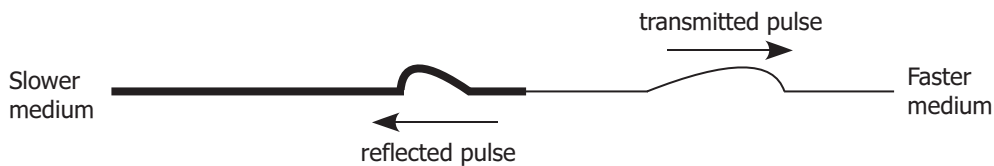

Again, there are several details to make note of:

Reflected Pulse	Transmitted Pulse
Returns as a crest – reflected upright from a free end	Transmitted as a crest
Smaller in amplitude – energy is transmitted	Larger in amplitude – light to medium is easier to move
Same length as original crest – speed is the same	Longer in length than the original crest – speed is larger in the transmitted section
Closer to the boundary	Farther from the boundary since the crest is moving more quickly

Outcome S3P-2-10, S3P-2-11

7. Describe two phenomena for the behaviour of light that are explained better using the wave model of light than the particle model of light.

Answer:

1. Refraction

The particle model predicts that particles of light will speed up as they pass through the boundary between air and water. The wave model correctly predicts that light will slow down as it passes through the boundary between air and water.

2. Partial reflection and partial refraction

The particle model could not fully explain why some particles would reflect off the boundary between two media and some particles would be transmitted through the boundary. The wave model of light demonstrates that waves incident on to the boundary between two media can partially be reflected and partially be transmitted.

Part C: Diagrams (15 Marks)

Show your work in the space provided.

Outcome S3P-1-06

1. Draw the resultant wave. (4 marks)

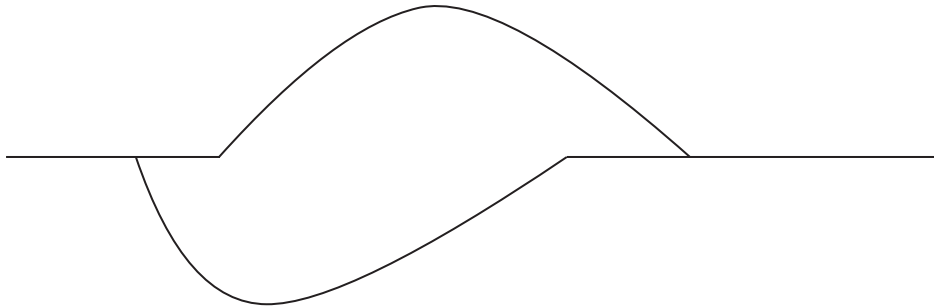

Point	Displacement to Top Wave (cm)	Displacement to Bottom Wave (cm)	Total Displacement (cm)
1	0	-1.7	-1.7
2	0.4	-1.9	-1.5
3	0.9	-1.9	-1.0
4	1.3	-1.7	-0.4
5	1.6	-1.5	0.1
6	1.9	-1.2	0.7
7	2.0	-1.0	1.0
8	1.9	-0.8	1.1
9	1.8	-0.4	1.4
10	1.5	-0.1	1.4

Answer:

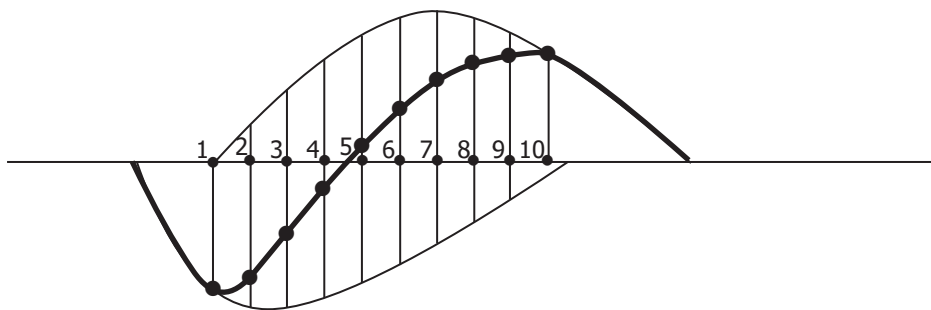

Outcome S3P-1-10

2. A point source on a ripple tank is located 3.5 cm from a straight barrier. Draw in, using a compass, the circular wave after it has travelled 5.0 cm. Locate the source of the reflected wavefront and draw in the reflected wavefront. Indicate the direction of travel of both the incident and reflected wavefronts. (3 marks)

Barrier



Answer:

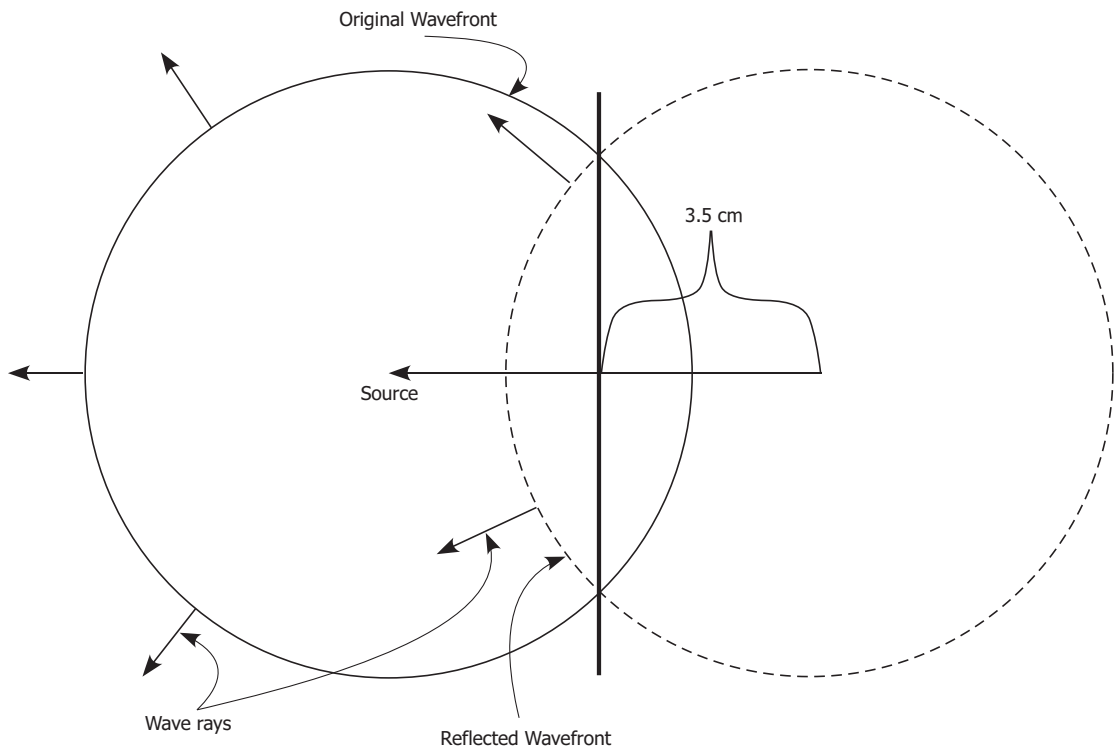

Outcome S3P-1-10

3. The diagram below shows a wavefront travelling towards a straight barrier. Draw in and label the direction of motion, the angle of incidence, the reflected crest, its direction of motion, and the angle of reflection. (3 marks)

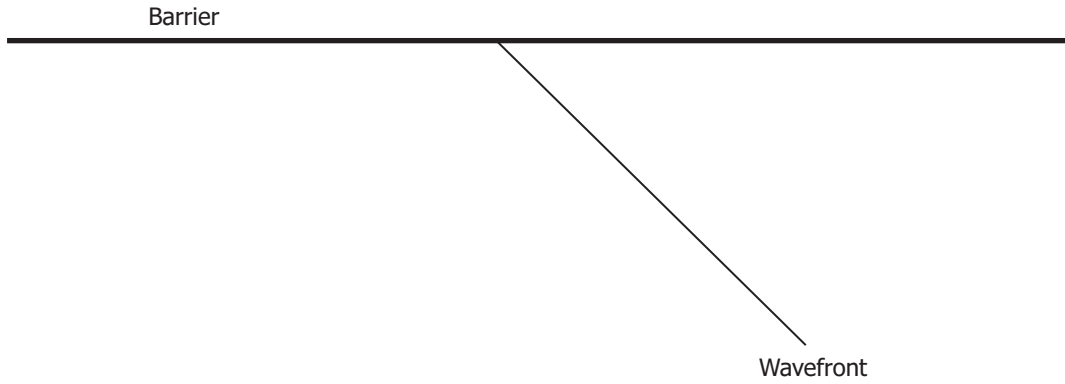

Answer:

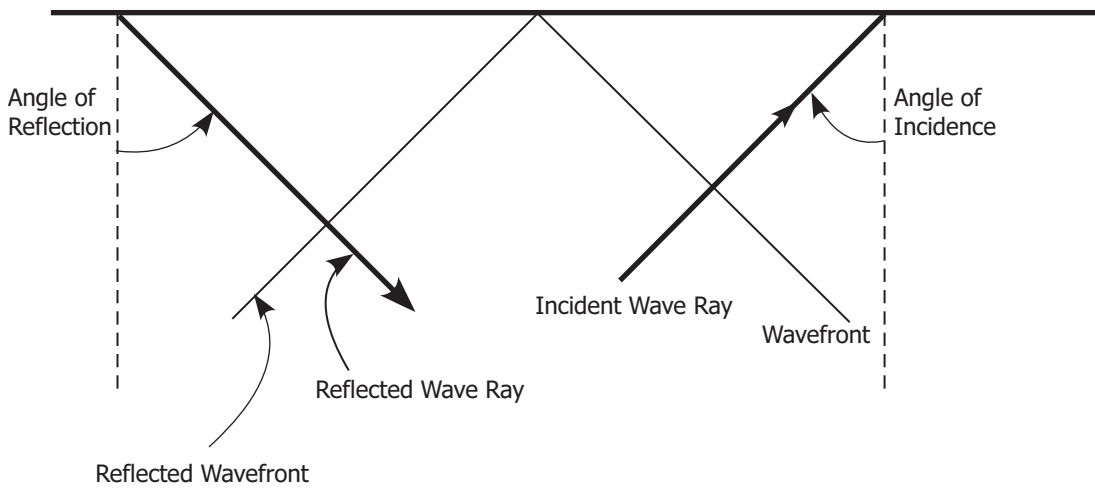

Outcome S3P-4-21

4. Draw the magnetic field around

a) a wire carrying a current out of the page. (1 mark)



Answer:

Magnetic Field around a Wire Carrying a Current OUT of the Page

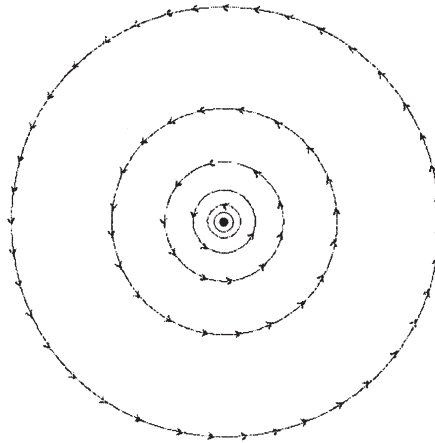

b) two positive point charges. (2 marks)

Answer:

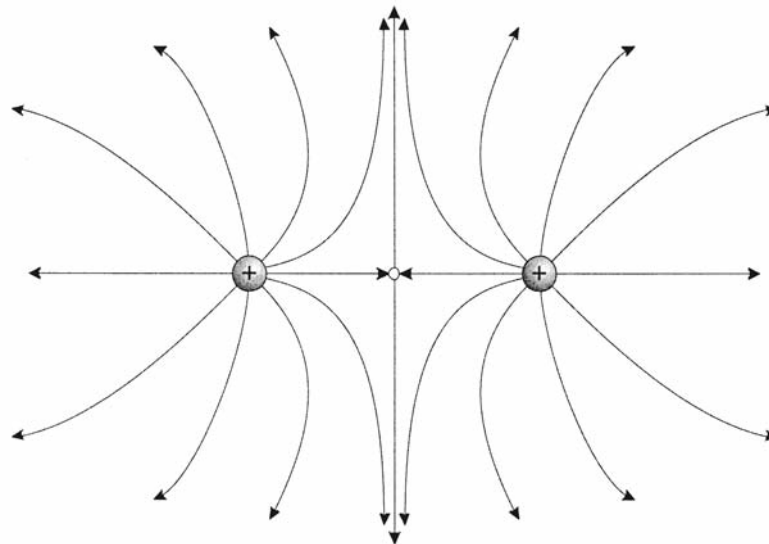

Outcome S3P-1-14

5. Diagram the diffraction of waves in the following situations:

a) at the edge of a straight barrier. (1 mark)

Answer:

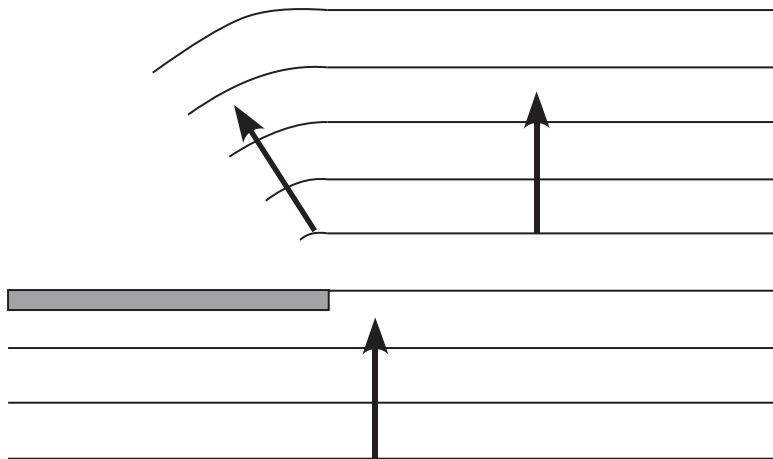

b) through the opening in a straight barrier. (1 mark)

Answer:

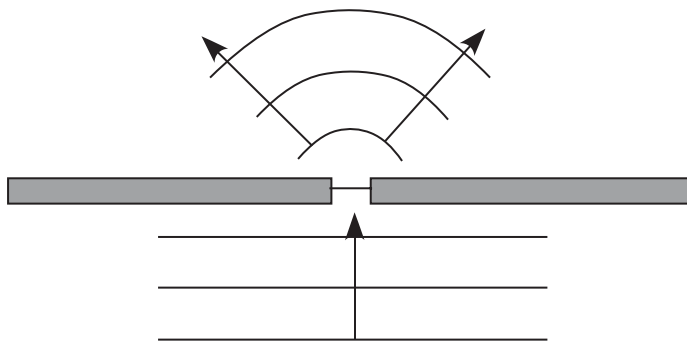

Part D: Problems (6 Marks)

Do only one question from Part D.

Outcome S3P-4-08

1. A baseball is popped straight upwards at 25.3 m/s. The acceleration of gravity is 9.80 m/s² downwards.

- a) Determine the highest point of the flight of the ball. (3 marks)

Answer:

Let down be negative.

Given: $\bar{v}_2 = 0 \text{ m/s}$

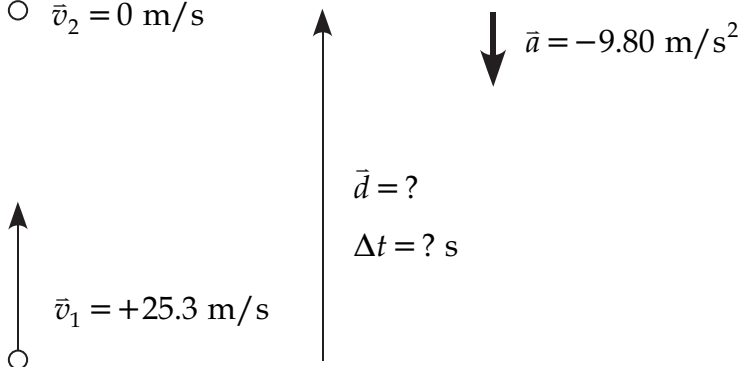

Unknown: Maximum height $\bar{d} = ?$

Equation: $v_2^2 = v_1^2 + 2ad$ rearranged to $d = \frac{v_2^2 - v_1^2}{2a}$

Substitute and solve: $d = \frac{v_2^2 - v_1^2}{2a} = \frac{(0 \text{ m/s})^2 - (+25.3 \text{ m/s})^2}{2(-9.80 \text{ m/s}^2)} = +32.6 \text{ m}$

The maximum height is 32.6 m.

- b) For what length of time would the ball rise from the instant it left the bat? (3 marks)

Answer:

Unknown: Time interval $\Delta t = ?$

Equation: $\bar{d} = \frac{(\bar{v}_1 + \bar{v}_2)}{2} \Delta t$ rearranged to $\Delta t = \frac{2\bar{d}}{\bar{v}_1 + \bar{v}_2}$

Substitute and solve: $\Delta t = \frac{2\bar{d}}{\bar{v}_1 + \bar{v}_2} = \frac{2(+32.6 \text{ m})}{(+25.3 \text{ m/s}) + (0)} = 2.58 \text{ s}$

It takes the ball 2.58 seconds to reach its maximum height.

2. A crate of mass 255 kg is pulled along a level floor. The crate rests on a dolly, which has a handle attached to it. The handle is pulled by a person exerting a force of 215 newtons at an angle of 42.0° from the horizontal, and the force of friction is 112 newtons.

Outcome S3P-0-2h

- a) Determine the horizontal and vertical components of the applied force acting on the crate. (2 marks)

Answer:

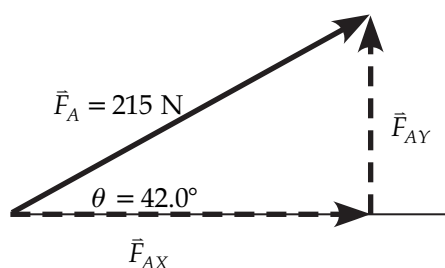

$$\vec{F}_{AX} = \cos 42.0^\circ (\vec{F}_A) = \cos 42.0^\circ (215 \text{ N}) = 160 \text{ N}$$

$$\vec{F}_{AY} = \sin 42.0^\circ (\vec{F}_A) = \sin 42.0^\circ (215 \text{ N}) = 144 \text{ N}$$

The vertical component of the applied force is 144 N and the horizontal component is 1.60×10^2 N.

Outcome S3P-3-12

- b) Draw a free-body diagram labelling clearly all of the forces acting on the dolly. (2 marks)

Answer:

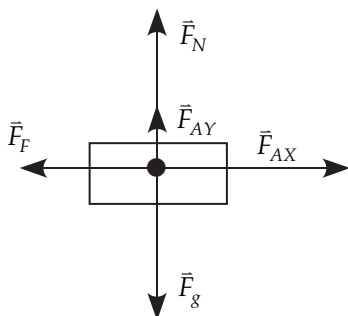

Outcome S3P-3-12, S3P-3-13

- c) Determine the net force acting on the dolly and the acceleration of the dolly.
(2 marks)

Answer:

The net force is the sum of the force of friction and the horizontal component of the applied force.

$$\vec{F}_{\text{NET}} = \vec{F}_F + \vec{F}_{AX} = 112 \text{ N [left]} + 160 \text{ N [right]} = 48 \text{ N [right]}$$

The acceleration is found using Newton's Second Law.

$$\vec{a} = \frac{\vec{F}_{\text{NET}}}{m} = \frac{48 \text{ N [right]}}{255 \text{ kg}} = 0.19 \text{ m/s}^2 \text{ [right]}$$

The acceleration is 0.19 m/s/s [right].

Part E: Problems (24 Marks)

Answer any four (4) problems. If more than four problems are done, the first four will be marked.

1. A 8.25 Hz water wave travels from deep water, where its speed is 42.0 cm/s, to shallow water where its speed is 31.5 cm/s. The angle of incidence is 30.0°. Find the following.

Outcome S3P-1-04

- a) the wavelengths in the two media (3 marks)

Answer:

Given: Frequency $f = 8.25 \text{ Hz}$

Speed in deep water $v_D = 42.0 \text{ cm/s}$

Speed in shallow water $v_S = 31.5 \text{ cm/s}$

Angle in deep water $\theta = 30.0^\circ$

Unknown: Wavelength in deep water $\lambda_D = ?$

Equation: $v = f\lambda$ rearranged to $\lambda_D = \frac{v_D}{f}$

Substitute and solve: $\lambda_D = \frac{v_D}{f} = \frac{42.0 \text{ cm/s}}{8.25 \text{ Hz}} = 5.09 \text{ cm}$

Similarly, for shallow water, the wavelength is calculated as

$$\lambda_S = \frac{v_S}{f} = \frac{31.5 \text{ cm/s}}{8.25 \text{ Hz}} = 3.82 \text{ cm.}$$

Outcome S3P-2-12

b) the angle of refraction in the shallow water (3 marks)

Answer:

Unknown: Angle in shallow water $\theta_s = ?$

Equation: Snell's Law: $\frac{\sin \theta_1}{\sin \theta_2} = \frac{v_1}{v_2} = \frac{\lambda_1}{\lambda_2}$

Here medium 1 is deep water and medium 2 is shallow water.

Substitute and solve:

$$\frac{\sin \theta_1}{\sin \theta_2} = \frac{v_1}{v_2}$$
$$\frac{\sin 30.0^\circ}{\sin \theta_s} = \frac{42.0 \text{ cm/s}}{31.5 \text{ cm/s}}$$
$$\sin \theta_s = \frac{(\sin 30.0^\circ)(31.5 \text{ cm/s})}{42.0 \text{ cm/s}} = 0.375$$
$$\theta_s = 22.0^\circ$$

The angle of refraction in shallow water is 22.0° .

2. Two point sources generate identical waves that interfere in a ripple tank. The sources are located 6.50 cm apart, and the frequency of the waves is 9.25 Hz. The waves travel at 12.6 cm/s.

Outcome S3P-1-04

- a) What is the wavelength of the waves? (2 marks)

Answer:

Given: Frequency $f = 9.25 \text{ Hz}$
 Speed of waves $v = 12.6 \text{ cm/s}$
 Distance between sources $d = 6.50 \text{ cm}$

Unknown: wavelength $\lambda = ?$

Equation: $v = f\lambda$ rearranged to $\lambda = \frac{v}{f}$

Substitute and solve: $\lambda = \frac{v}{f} = \frac{12.6 \text{ cm/s}}{9.25 \text{ Hz}} = 1.36 \text{ cm}$

The wavelength is 1.36 cm.

Outcome S3P-1-16

- b) What is the path length difference to a point P on the third nodal line? (1.5 marks)

Answer:

Given: number of nodal line $n = 3$

Unknown: Path length difference PLD = ?

Equation: $|\overline{P_n S_1} - \overline{P_n S_2}| = \left(n - \frac{1}{2}\right)\lambda$

Substitute and solve: $|\overline{P_n S_1} - \overline{P_n S_2}| = \left(n - \frac{1}{2}\right)\lambda$
 $= \left(3 - \frac{1}{2}\right)(1.36 \text{ cm}) = 3.40 \text{ cm}$

The path length difference is 3.40 cm.

Outcome S3P-1-16

- c) What would happen to the spacing of the nodal lines in the interference pattern if only the distance between the sources was increased? (1.5 marks)

Answer:

If the spacing between the sources was to increase, this would place more points in the pattern within the same space. This would lead to a greater number of nodal lines. In turn, the nodal line must be spaced closer together.

Outcome S3P-1-16

- d) What would happen to the number of nodal lines in the interference pattern if only the frequency of the waves was increased? (1 mark)

Answer:

If the frequency of the waves was increased, this would decrease the distance between points of interference in the pattern. This, in turn, would increase the number of nodal lines.

3. An air column closed at one end resonates at the second maximum or the second resonant length. The frequency of the sound wave is 1024 Hz. The air temperature is 18.6°C.

Outcome S3P-1-21

- a) Draw a diagram of the displacement wave pattern inside the column. (1 mark)

Answer:

The length of the closed air column at the second maximum is $\frac{3}{4}\lambda$.

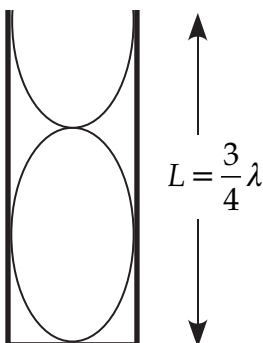

Outcome S3P-1-23

- b) Calculate the speed of sound in air. (2 marks)

Answer:

Given: Air temperature $T = 18.6^\circ\text{C}$

Unknown: Speed of sound $v = ?$

Equation: $v = 331 \text{ m/s} + (0.60 \text{ m/s}/^\circ\text{C})T$

Substitute and solve: $v = 331 \text{ m/s} + (0.60 \text{ m/s}/^\circ\text{C})(18.6^\circ\text{C})$

$v = 331 + 11.16 = 342 \text{ m/s}$

The speed of sound is 342 m/s.

Outcome S3P-1-04

c) Calculate the wavelength. (1.5 marks)

Answer:

Given: Frequency $f = 1024 \text{ Hz}$

Speed $v = 342 \text{ m/s}$

Unknown: wavelength $\lambda = ?$

Equation: $v = f\lambda$ rearranged to $\lambda = \frac{v}{f}$

Substitute and solve: $\lambda = \frac{v}{f} = \frac{342 \text{ m/s}}{1024 \text{ Hz}} = 0.334 \text{ m}$

The wavelength is 0.334 m.

Outcome S3P-1-21

d) Calculate the length of the closed air column. (1.5 marks)

Answer:

The length of the closed air column is $\frac{3}{4}\lambda$ or $\frac{3}{4}(0.334 \text{ m}) = 0.250 \text{ m}$.

4. In a standing wave pattern on a spring, the distance between the third and seventh nodes is 1.52 m. The source generates 25 crests and 25 troughs in 5.40 seconds.

Outcome S3P-1-03

- a) What is the frequency? (1.5 marks)

Answer:

25 waves are generated in 5.40 seconds.

$$f = \frac{\text{number of events}}{\text{time}} = \frac{25}{5.40 \text{ s}} = 4.6 \text{ Hz}$$

Outcome S3P-1-05

- b) What is the wavelength? (2 marks)

Answer:

The distance between the 3rd and 7th nodes is 2 wavelengths.

$$2\lambda = 1.52 \text{ m}$$

$$\lambda = 0.760 \text{ m}$$

The wavelength is 0.760 m.

Outcome S3P-1-04

- c) What is the speed of these waves? (1.5 marks)

Answer:

$$v = f\lambda = (4.6 \text{ Hz})(0.760 \text{ m}) = 3.5 \text{ m/s}$$

Outcome S3P-1-28

- d) What would be the frequency of the wave one octave above the given wave?
(1 mark)

Answer:

One octave above a given frequency is twice the given frequency. So, one octave above 4.6 Hz is 9.2 Hz.

5. In a Young's Experiment measurement, light of wavelength $5.25 \times 10^{-7} \text{ m}$ passed through 2 slits $2.78 \times 10^{-5} \text{ m}$ apart.

Outcome S3P-2-14

- a) At a distance of 2.75 m, what would be the spacing of the adjacent nodal lines in this pattern? (3 marks)

Answer:

Given: Wavelength $\lambda = 5.25 \times 10^{-7} \text{ m}$

Separation of slits $d = 2.78 \times 10^{-5} \text{ m}$

Distance to pattern $L = 2.75 \text{ m}$

Unknown: Spacing of nodal lines $\Delta x = ?$

Equation: $\lambda = \frac{\Delta x d}{L}$ rearranged to $\Delta x = \frac{\lambda L}{d}$

Substitute and solve:
$$\Delta x = \frac{\lambda L}{d} = \frac{(5.25 \times 10^{-7} \text{ m})(2.75 \text{ m})}{2.78 \times 10^{-5} \text{ m}} = 5.19 \times 10^{-2} \text{ m}$$

The spacing of adjacent nodal lines is $5.19 \times 10^{-2} \text{ m}$.

Outcome S3P-2-13

- b) What is the spacing of adjacent nodal lines if only light of wavelength $6.75 \times 10^{-7} \text{ m}$ was used instead of $5.25 \times 10^{-7} \text{ m}$? (1.5 marks)

Answer:

Only the wavelength changes to $6.75 \times 10^{-7} \text{ m}$.

$$\Delta x = \frac{\lambda L}{d} = \frac{(6.75 \times 10^{-7} \text{ m})(2.75 \text{ m})}{2.78 \times 10^{-5} \text{ m}} = 6.68 \times 10^{-2} \text{ m}$$

The new spacing is $6.68 \times 10^{-2} \text{ m}$.

Outcome S3P-2-13

- c) What is the spacing of adjacent nodal lines if only the spacing of the two slits is changed to $3.50 \times 10^{-5} \text{ m}$? (1.5 marks)

Answer:

Only the separation of the slits is changed from the original situation to $3.50 \times 10^{-5} \text{ m}$.

$$\Delta x = \frac{\lambda L}{d} = \frac{(5.25 \times 10^{-7} \text{ m})(2.75 \text{ m})}{3.50 \times 10^{-5} \text{ m}} = 4.12 \times 10^{-2} \text{ m}$$

The new spacing of the nodal lines is $4.12 \times 10^{-2} \text{ m}$.

Outcome S3P-2-14

6. Two slits have green light of wavelength 5.25×10^{-7} m passing through them. The interference pattern is observed at a distance of 1.75 m. The distance from the first dark line to the ninth dark line is 10.2 cm.
- a) What is the spacing of the nodal lines? (2 marks)

Answer:

There are 8 spaces between the 9 nodal lines.

$$\Delta x = \frac{10.2 \text{ cm}}{8} = 1.28 \text{ cm} = 1.28 \times 10^{-2} \text{ m}$$

- b) What is the separation of the slits? (3 marks)

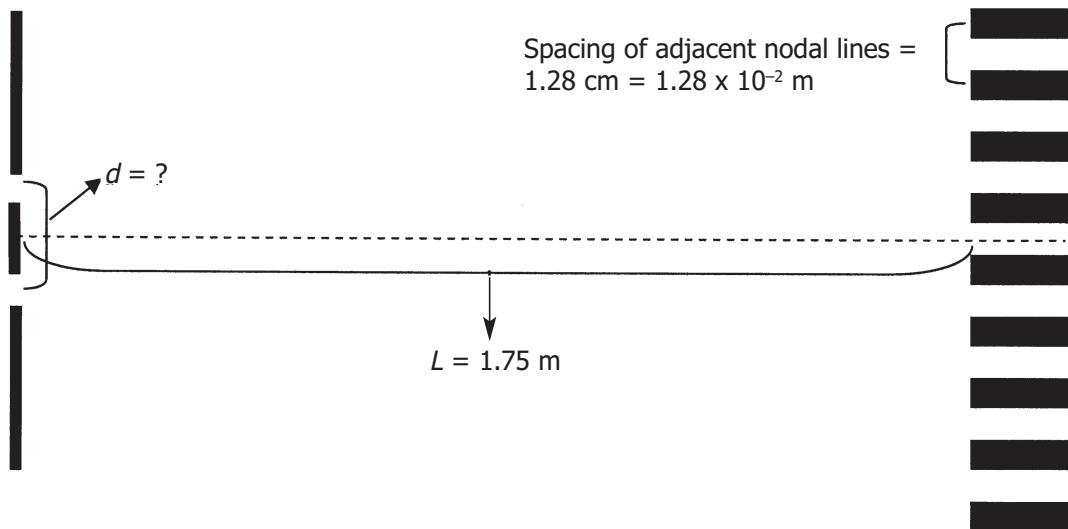

Answer:

Given: Wavelength $\lambda = 5.25 \times 10^{-7}$

Unknown: Separation of slits $d = ?$

Equation: $\Delta x = \frac{\lambda L}{d}$ rearranged to $d = \frac{\lambda L}{\Delta x}$

Substitute and solve: $d = \frac{\lambda L}{\Delta x} = \frac{(5.25 \times 10^{-7} \text{ m})(1.75 \text{ m})}{1.28 \times 10^{-2} \text{ m}} = 7.18 \times 10^{-5} \text{ m}$

The separation of the slits is 7.18×10^{-5} m.

- c) Should light of a larger or smaller wavelength be used in this situation to produce a pattern of lines that is spaced closer together? Explain why. (1 mark)

Answer:

According to the relationship for Young's Experiment, $\Delta x = \frac{\lambda L}{d}$, the spacing of the lines varies directly with the wavelength. For the lines to be spaced closer together, a smaller wavelength must be used.

NOTES

Grade 11 Physics

Formula Sheet

Mathematics

$$\sin \theta = \frac{\text{opposite}}{\text{hypotenuse}}$$

$$\cos \theta = \frac{\text{adjacent}}{\text{hypotenuse}}$$

$$\tan \theta = \frac{\text{opposite}}{\text{adjacent}}$$

$$\text{hypotenuse}^2 = (\text{Leg 1})^2 + (\text{Leg 2})^2$$

Kinematics

$$v = \frac{d}{\Delta t}$$

$$\Delta = \text{second value} - \text{first value}$$

$$\bar{d} = \text{pos}_2 - \text{pos}_1$$

$$\bar{v} = \frac{\bar{d}}{\Delta t} = \frac{\text{pos}_2 - \text{pos}_1}{\Delta t}$$

$$\bar{a} = \frac{\Delta \bar{v}}{\Delta t} \text{ or } \bar{a} = \frac{\bar{v}_2 - \bar{v}_1}{\Delta t} \text{ or } \bar{v}_2 = \bar{v}_1 + \bar{a}\Delta t$$

$$\bar{d} = \frac{1}{2}(\bar{v}_1 + \bar{v}_2)\Delta t$$

$$\bar{d} = \bar{v}_1\Delta t + \frac{1}{2}\bar{a}\Delta t^2$$

$$v_2^2 = v_1^2 + 2ad$$

Waves

$$\frac{\sin \theta_1}{\sin \theta_2} = \frac{\lambda_1}{\lambda_2} = \frac{v_1}{v_2} = \frac{n_2}{n_1} = n_{1-2}$$

$$\text{PLD} = |\text{PS}_1 - \text{PS}_2|$$

$$f = \frac{1}{T}$$

$$T = \frac{1}{f}$$

$$v = f\lambda$$

Light

$$\text{PLD} = |\text{PS}_1 - \text{PS}_2|$$

$$\frac{\Delta x}{L} = \frac{\lambda}{d}$$

Sound

$$v = 332 + 0.6 T$$

Closed-pipe resonant length

$$L_n = \left(\frac{2n-1}{4}\right)\lambda$$

Open-pipe resonant length

$$L_n = \left(\frac{n}{2}\right)\lambda$$

$$f_B = |f_2 - f_1|$$

Dynamics

$$\vec{F}_{\text{NET}} = m\bar{a}$$

$$\vec{F}_{\text{NET}} = \sum \text{Forces}$$

$$F_f = \mu F_N$$

Gravity

$$\vec{F}_g = m\bar{g}$$

$$\vec{F}_N + \vec{F}_g = \vec{F}_{\text{NET}} = m\bar{a}$$

Electricity

$$\vec{E} = \frac{\vec{F}_E}{q}$$

$$q = Ne$$

$$E = \frac{V}{d}$$

Magnetism

$$\vec{F}_B = BIL \sin \theta$$

