



GRADE 10 ESSENTIAL  
MATHEMATICS (20S)

Midterm Practice Exam  
Answer Key



# GRADE 10 ESSENTIAL MATHEMATICS

## Midterm Practice Examination Answer Key

Name: \_\_\_\_\_

Student Number: \_\_\_\_\_

Attending  Non-Attending

Phone Number: \_\_\_\_\_

Address \_\_\_\_\_  
\_\_\_\_\_  
\_\_\_\_\_

For Marker's Use On

Date: \_\_\_\_\_

Final Mark \_\_\_\_\_ /100 = \_\_\_\_\_ %

Comments:

---

### Instructions

The midterm examination will be weighted as follows:

Modules 1-4 100%

The format of the examination will be as follows:

Part A: Multiple Choice 9 marks

Part B: Long Answer 91 marks

Time allowed: 2.5 hours

**Note:** You are allowed to bring the following to the exam: pens/pencils (2 or 3 of each), blank paper, a scientific calculator, and your Midterm Exam Resource Sheet. Your Midterm Exam Resource Sheet must be handed in with the exam. You will receive your Midterm Exam Resource Sheet back from your tutor/marker with the next module work that is submitted for marking.



Part A: Multiple Choice (9 x 1 = 9 marks)

Circle the letter of the correct answer for each question.

1. A best estimate of the amount of liquid a soda can holds is

- a) 350 litres
- b) 35 gallons
- c) 350 mL
- d) 350 fl. oz.

Module 3, Lesson 5

2. CPP is known as

- a) income from the federal government when between jobs
- b) retirement income from the federal government
- c) amount deducted from gross earnings
- d) a savings plan

Module 2, Lesson 2

3. Overtime pay may be defined as

- a) earnings after deductions have been taken off
- b) earnings before any deductions have been taken off
- c) earnings for more than 8 hours per day
- d) income from the government when you are laid off from your job

Module 1, Lesson 4

4. Deductions are defined as

- a) earnings after deductions have been taken off
- b) earnings before deductions have been taken off
- c) earnings more than 8 hours per day
- d) amount that gross pay is reduced by

Module 2, Lesson 1

5. Workers are paid by piecework when

- a) they work more than 40 hours per week
- b) they work on weekends
- c) they are paid based on the number of items they assemble
- d) they work shift work

Module 1, Lesson 3

6. Workers who are paid by a commission are likely
- a) teenagers working part-time in fast food restaurants
  - b) teachers, managers, government workers
  - c) car salespeople, realtors, insurance salesmen
  - d) commissionaires and security people

Module 1, Lesson 3

7. The heaviest measurement is

- a) kilogram
- b) pound
- c) ounce
- d) gram

Module 3, Lesson 5

8. The smallest unit of measurement on a standard imperial ruler is

- a)  $\frac{1}{4}$ "
- b)  $\frac{1}{2}$ "
- c)  $\frac{1}{8}$ "
- d)  $\frac{1}{16}$ "

Module 3, Lesson 4

9. A square measuring one yard by one yard has an area of

- a) 144 sq. ft
- b) 9 sq. ft.
- c) 3 sq. ft.
- d) 36 square inches

Module 4, Lesson 5

Part B: Long Answer (91 marks)

Write your answers in the space provided.

1. Nancy is paid overtime on any hours worked over 8 per day. Using this time card, identify how many regular hours and how many overtime hours she worked last week. (2 marks) (Module 1, Lesson 4)

Monday	Tuesday	Wednesday	Thursday	Friday
6	11.5	7.5	9.25	9.5

Regular:            *Answer:*  $6 + 8 + 7.5 + 8 + 8 = 37.5$  hours

Overtime:        *Answer:*  $3.5 + 1.25 + 1.5 = 6.25$  hours

2. Identify four methods you studied by which workers can earn income. (4 marks) (Module 1, Lesson 3)

*Answer:*

Any four: salary, hourly wage, commission, contract, piecework, salary plus commission

3. Explain why a salesman might prefer to be paid by commission. Also, describe what would be needed for the salesman to succeed. (2 marks) (Module 1, Lesson 3)

*Answer:*

Various answers are acceptable.

Unlimited income if sales are good, control of his/her own income.

He/she will need to be open with people, to be personable, to sell a good product people want, to be where the customers are.

4. Jon offers to totally landscape his aunt's yard for \$2000. This is an example of earning income by what method? (1 mark) (Module 1, Lesson 3)

Answer: contract

5. Fill in the time card to find the gross pay. Overtime is paid at time and one-half on any hours over 40 hours per week. There are no late penalties. (7 marks) (Module 1, Lesson 5)

Employee: Scott					Hourly Rate: \$11.75		
Day	Morning In	Out	Afternoon In	Out	Evening In	Out	Total
Mon.	07:30	12:00	1:00	5:00	7:30	9:45	10.75
Tues.	07:29	11:59	12:58	4:30			8
Wed.			1:00	5:30	7:30	10:15	7.25
Thurs.	07:30	12:02	1:01	5:32	7:00	10:30	12.5
Fri.	08:00	12:00	1:02	5:00			8
Sat.			1:00	4:45			3.75
Sun.							
							50.25
		Hours		Rate		Amount	
Regular		40		\$11.75		40 x \$11.75 = \$470.00	
Overtime		10.25		\$11.75 x 1.5 = \$17.63		10.25 x \$17.63 = \$180.71	
Total Hours		50.25		Gross Wages		\$470 + \$180.71 = \$650.71	

6. List six possible deductions one might expect from their gross earnings. (6 marks) (Module 2, Lesson 1)

Answer:

Any six of: dental plan, social fund, coffee, water, parking, CPP, EI, federal and provincial income tax, union dues, RSP

7. Jessica earns \$11.44 per hour. She works 35 hours. Use the payroll deduction tables to find her net pay. Her claim code is 0. (7 marks) (Module 2, Lesson 5)

Canada Pension Plan Contributions  
**Weekly (52 pay periods a year)**

Pay Rémunération		CPP RPC	Pay Rémunération		CPP RPC
From - De	To - Á		From - De	To - Á	
399.93	- 400.12	16.47	438.11	- 438.31	18.36
400.13	- 400.33	16.48	438.32	- 438.51	18.37
400.34	- 400.53	16.49	438.52	- 438.71	18.38
400.54	- 400.73	16.50	438.72	- 438.91	18.39
400.74	- 400.93	16.51	438.92	- 439.11	18.40
400.94	- 401.13	16.52	439.12	- 439.32	18.41
401.14	- 401.34	16.53	439.33	- 439.52	18.42
401.35	- 401.54	16.54	439.53	- 439.72	18.43
401.55	- 401.74	16.55	439.73	- 439.92	18.44

**Employment Insurance Premiums**

Insurable Earnings Rémunération assurable		EI premium Cotisation d'AE	Insurable Earnings Rémunération assurable		EI premium Cotisation d'AE
From - De	To - Á		From - De	To - Á	
395.67	- 396.24	6.85	437.29	- 437.86	7.57
396.25	- 396.82	6.86	437.87	- 438.43	7.58
396.83	- 397.39	6.87	438.44	- 439.01	7.59
397.40	- 397.97	6.88	439.02	- 439.59	7.60
397.98	- 398.55	6.89	439.60	- 440.17	7.61
398.56	- 399.13	6.90	440.18	- 440.75	7.62
399.14	- 399.71	6.91	440.76	- 441.32	7.63
399.72	- 400.28	6.92	441.33	- 441.90	7.64
400.29	- 400.66	6.93	441.91	- 442.48	7.65

---

**Federal tax deductions**

Effective January 1, 2009

Weekly (52 pay periods a year)

**Also look up the tax deductions  
in the provincial table**

Pay Rémunération		Federal claim codes/ Codes de demande			
		0	1	2	3
From De	Less than Moins de	Deduct from each pay Retenez sur chaque paie			
399	- 403	53.60	24.50	21.65	15.95
403	- 407	54.20	25.05	22.20	16.50
407	- 411	54.75	25.60	22.75	17.05
411	- 415	55.30	26.15	23.30	17.65
415	- 419	55.85	26.75	23.90	18.20
419	- 423	56.40	27.30	24.45	18.75
423	- 427	57.00	27.85	25.00	19.30
427	- 431	57.55	28.40	25.55	19.85
431	- 435	58.10	28.95	26.10	20.45
435	- 439	58.65	29.50	26.70	21.00
439	- 443	59.20	30.10	27.25	21.55

---

**Manitoba provincial tax deductions**

Effective January 1, 2009

Weekly (52 pay periods a year)

**Also look up the tax deductions  
in the federal table**

Pay Rémunération		Provincial claim codes/ Codes de demande			
		0	1	2	3
From De	Less than Moins de	Deduct from each pay Retenez sur chaque paie			
397	- 401	40.55	23.70	21.90	18.40
401	- 405	41.00	24.10	22.30	18.80
405	- 409	41.40	24.50	22.75	19.20
409	- 413	41.80	24.90	23.15	19.60
413	- 417	42.20	25.30	23.55	20.00
417	- 421	42.60	25.70	23.95	20.40
421	- 425	43.00	26.10	24.35	20.80
425	- 429	43.40	26.50	24.75	21.25
429	- 433	43.80	26.90	25.15	21.65
433	- 437	44.20	27.30	25.55	22.05
437	- 441	44.60	27.70	25.95	22.45

Gross earnings:

*Answer:*  $\$11.44 \times 35 = \$400.40$

CPP: *Answer: \$16.49*

EI: *Answer: \$6.93*

Federal income tax, claim code 0: *Answer: \$53.60*

Manitoba income tax, claim code 0: *Answer: \$40.55*

Total deductions: *Answer: \$16.49 + \$6.93 + \$53.60 + \$40.55 = \$117.57*

Net pay: *Answer: \$400.40 - \$117.57 = \$282.83*

8. Joey works at a sporting goods store assembling bicycles. He gets paid \$12 for each bike he assembles, but loses \$8 for every bike that is not put together properly. Last week he worked 60 hours to assemble 65 bicycles before a big sale. The boss brought 11 bikes back because they were missing parts. Calculate Joey's income earned. (1 mark)  
(Module 1, Lesson 3)

*Answer:*

Earnings for bikes assembled =  $\$12 \times 65 = \$780$

Earnings lost for improper assembly =  $\$8 \times 11 = \$88$

Total earnings =  $\$780 - \$88 = \$692$

- 9 How much more federal income tax will you pay if you get a \$1 per hour raise, assuming you earn \$10 per hour, work 40 hours per week, and use claim code 2. (1 mark)  
(Module 2, Lesson 4)

*Answer:*

$$\text{Income tax at } \$10/\text{hour} = 10 \times 40 = \$400$$

$$\text{Federal tax} = \$21.65$$

$$\text{Income at } \$11/\text{hour} = 11 \times 40 = \$440$$

$$\text{Federal tax} = \$27.25$$

$$\text{Extra tax to be paid} = \$27.25 - \$21.65 = \$5.60$$

10. Jamie earns a salary of \$40,040.00 per year. She pays \$10 for union dues and \$15 for parking. Use 4.95% for CPP, 1.73% for EI, and 29% for the combined federal and provincial income taxes to find her net weekly pay. (7 marks) (Module 2, Lesson 5)

Gross weekly earnings: *Answer:*  $\$40,040/52 = \$770.00$

CPP: *Answer:*  $\$770 \times 0.0495 = \$38.12$

EI: *Answer:*  $\$770 \times 0.0173 = \$13.32$

Income tax: *Answer:*  $\$770 \times 0.29 = \$223.30$

Other deductions: *Answer:*  $\$10 + \$15 = \$25$

Total deductions: *Answer:*  $\$38.12 + \$13.32 + \$223.30 + \$25 = \$299.74$

Net pay: *Answer:*  $\$770 - \$299.74 = \$470.26$

11. Fred is paid a salary of \$80,000 per year. Find his annual provincial income taxes using the marginal rates tables shown below. (5 marks) (Module 2, Lesson 4)

**Manitoba Marginal Rates**

Any annual income from \$0 to \$31,000: 10.8%

plus any annual income from \$31,001 to \$67,000: 12.75%

plus any annual income from \$67,000: 17.4%

*Answer:*

Since Fred's income spills over into the second and third marginal levels, he will pay the maximum amounts in the first and second levels, and the spillover for the third level.

First level, income tax =  $\$31,000 \times 0.108 = \$3348$

Second level, income tax =  $(\$67,000 - \$31,000) \times 0.1275 = \$36,000 \times 0.1275 = \$4590$

Third level, income tax =  $(\$80,000 - \$67,000) \times 0.174 = \$13,000 \times 0.174 = \$2262$

Total provincial tax =  $\$3348 + \$4590 + \$2262 = \$10,200$ .

12. Find the readings on this imperial ruler. (4 marks) (Module 3, Lesson 4)

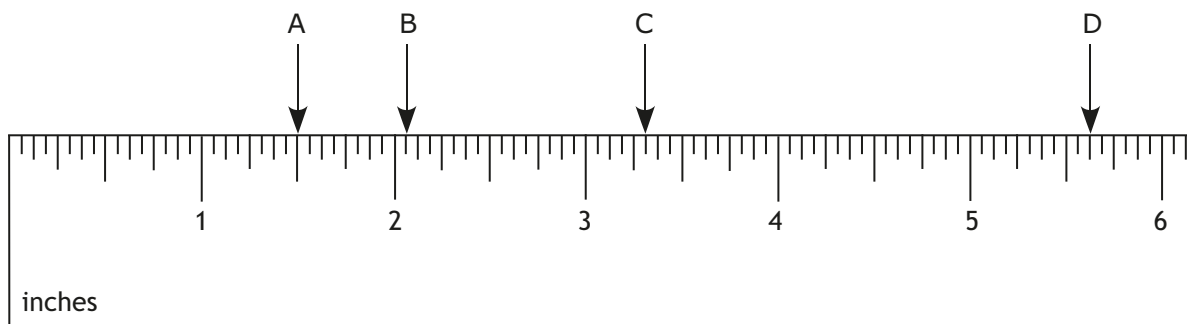

Answers:

A  $1\frac{1}{2}$ "

B  $2\frac{1}{16}$ "

C  $3\frac{5}{16}$ "

D  $5\frac{5}{8}$ "

13. Record the readings in centimetres on this metric ruler. (4 marks) (Module 3, Lesson 4)

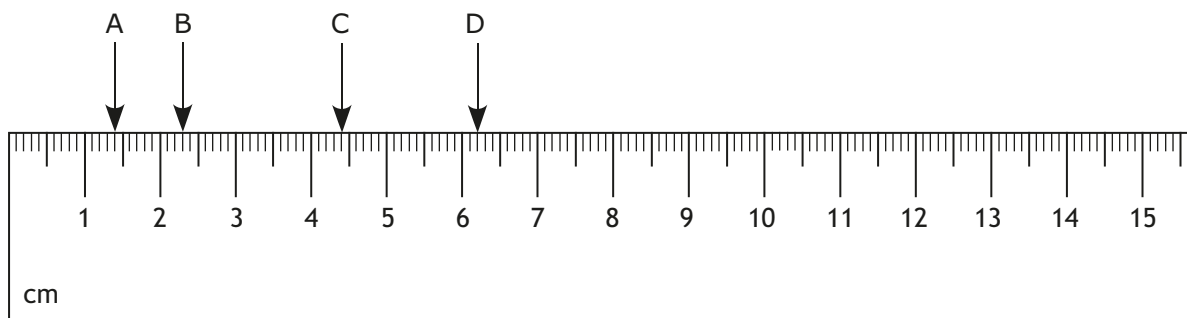

Answers:

A 1.4 cm

B 2.3 cm

C 4.4 cm

D 6.2 cm

14. Given that the temperature is  $110^{\circ}\text{F}$ , find the equivalent Celsius temperature by using the formula. Show your work. (3 marks) (Module 3, Lesson 8)

Answer:

Formula:  $F = C \times 1.8 + 32$

Substitute:  $110 = C \times 1.8 + 32$

Solve:  $110 - 32 = C \times 1.8$

$$78 = 1.8C$$

$$\frac{78}{1.8} = \frac{1.8C}{1.8}$$

$$43.33 = C$$

The Celsius temperature is  $43.33^{\circ}\text{C}$ .

15. Use the conversion table to convert the following. Round off to two decimal places. Show your work. (4 marks) (Module 3, Lesson 5)

Basic Conversion Formulas between Systems	
Mass	1 kg = 2.2 pounds 454 g = 1 pound 28.4 grams = 1 ounce
Capacity	1 gallon (Canadian) = 4.54 L 1 fl. oz. (Canadian) = 28.41 mL 1 gallon (American) = 3.785 L 1 fl. oz. (American) = 29.57 mL
Distance	1 mile = 1.61 km 1 km = 0.62 mi. 1 inch = 2.54 cm 1 metre = 1.094 yards

a)  $9 \text{ km} = \underline{\hspace{2cm}}$  miles

*Answer:*

$$1 \text{ km} = 0.62 \text{ miles}$$

$$9 \text{ km} = 9 \times 0.62 = 5.58 \text{ miles}$$

b)  $25 \text{ fl. oz.} = \underline{\hspace{2cm}}$  mL (Canadian)

*Answer:*

$$1 \text{ fl. oz.} = 28.41 \text{ mL}$$

$$25 \text{ fl. oz.} = 25 \times 28.41 = 710.25 \text{ mL}$$

c)  $150 \text{ pounds} = \underline{\hspace{2cm}}$  kg

*Answer:*

1 kg	2.2 pounds
$x$ kg	150 pounds

$$\frac{1}{x} = \frac{2.2}{150}$$

$$(x)(2.2) = (1)(150)$$

$$2.2x = 150$$

$$\frac{2.2x}{2.2} = \frac{150}{2.2}$$

$$x = 68.18$$

Thus, 150 pounds = 68.18 kg.

d) 350 cm = \_\_\_\_\_ inches

*Answer:*

1 inch	2.54 cm
x gallons	350 cm

$$\frac{1}{x} = \frac{2.54}{350}$$

$$(x)(2.54) = (1)(350)$$

$$2.54x = 350$$

$$\frac{2.54x}{2.54} = \frac{350}{2.54}$$

$$x = 137.80$$

Thus, 350 cm = 137.80 inches.

16. The distance from Winnipeg to Minneapolis is about 500 miles. How far is the distance in kilometres? The conversion rules are given in #15 above. (2 marks)  
(Module 3, Lesson 5)

*Answer:*

$$1 \text{ mile} = 1.61 \text{ km}$$

$$500 \text{ miles} = 500 \times 1.61 = 805 \text{ km}$$

17. Record the metric Vernier caliper readings. (2 marks) (Module 3, Lesson 6)

**Note:** Your answer will be marked correct if it is  $\pm 0.02$  from the given answer.

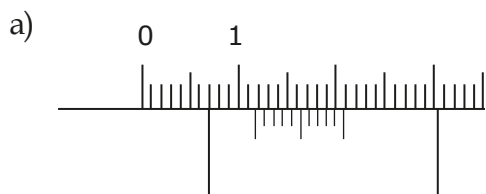

*Answer:*

Reading = 1.18 cm

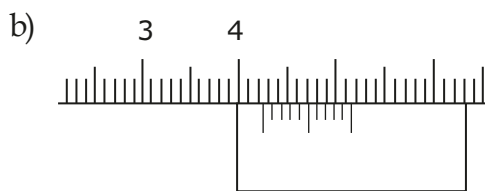

*Answer:*

Reading = 4.26 cm

18. Record the micrometer readings. (2 marks) (Module 3, Lesson 7)

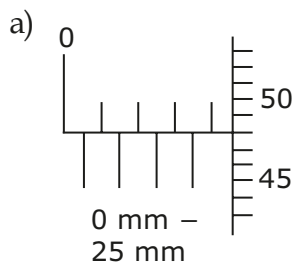

*Answer:*

Reading = 4.48 mm

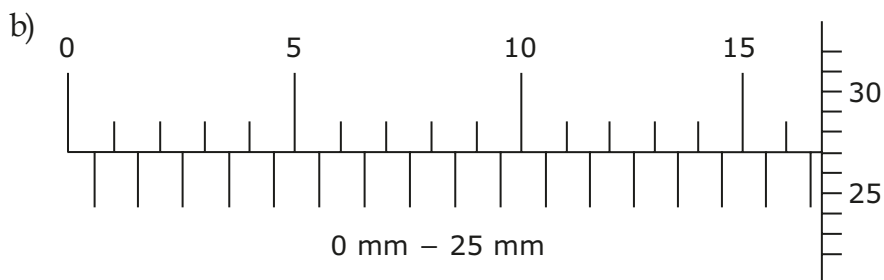

*Answer:*

Reading = 16.77 mm

19. Find the area of each shape. (9 marks) (Module 4, Lesson 2)

a)

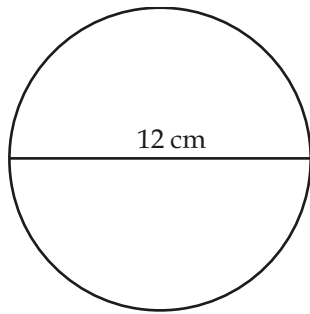

*Answer:*

$$A = \pi r^2$$

$$A = 3.14(6 \text{ cm})^2$$

$$A = 113.04 \text{ cm}^2$$

b)

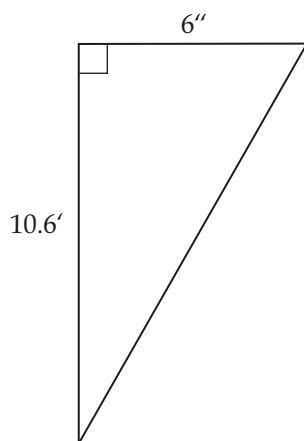

*Answer:*

First, change the units to feet.

1 foot = 12 inches

$$6 \text{ inches} = \frac{6}{12} = 0.5 \text{ feet}$$

$$A = \frac{1}{2}bh$$

$$A = \frac{1}{2}(0.5' \times 10.6')$$

$$A = \frac{1}{2}(5.3')$$

$$A = 2.65 \text{ sq. ft.}$$

If you changed to the same units of inches, the solution would be as follows:

$$1 \text{ foot} = 12 \text{ inches}$$

$$10.6 \text{ feet} = 10.6 \times 12 = 127.2 \text{ inches}$$

$$A = \frac{1}{2}bh$$

$$A = \frac{1}{2}(127.2'' \times 6'')$$

$$A = \frac{1}{2}(763.2'')$$

$$A = 381.6 \text{ sq. in.}$$

Either answer is acceptable.

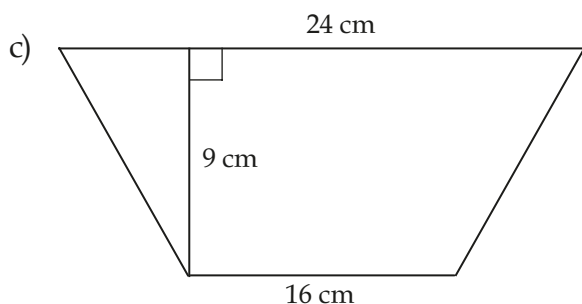

*Answer:*

$$A = \frac{1}{2}h(b_1 + b_2)$$

$$A = \frac{1}{2}(9 \text{ cm})(16 \text{ cm} + 24 \text{ cm})$$

$$A = 180 \text{ cm}^2$$

20. You have enough sod to cover  $300 \text{ m}^2$  of your lawn. Knowing the length of the lawn is 40 m, find the width. (2 marks) (Module 4, Lesson 2)

*Answer:*

Formula:  $A = lw$

Substitute:  $300 = 40w$

Solve  $\frac{300}{40} = \frac{40w}{40}$

$$7.5 = w$$

The width of your lawn is 7.5 m.

21. You use a piece of string to find the direct distance between two points on a map. The length of the string is 4.6 cm long. The map scale is 1 cm: 200 miles. Find the direct distance between the points. (2 marks) (Module 4, Lesson 3)

*Answer:*

1 cm: 200 miles

4.6 cm =  $4.6 \times 200 = 920$  miles

22. Convert the following measurements as indicated using the area conversions chart. Round off to two decimal places. (9 marks) (Module 4, Lesson 5)

Imperial		Metric
1 in. <sup>2</sup>		6.4516 cm <sup>2</sup>
1 ft. <sup>2</sup>	144 in. <sup>2</sup>	0.0929 m <sup>2</sup>
1 yd. <sup>2</sup>	9 ft. <sup>2</sup>	0.8361 m <sup>2</sup>
1 acre	4840 yd. <sup>2</sup>	4046.9 m <sup>2</sup>
1 mile <sup>2</sup>	640 acres	2.59 km <sup>2</sup>

Metric		Imperial
1 cm <sup>2</sup>	100 mm <sup>2</sup>	0.1550 in. <sup>2</sup>
1 m <sup>2</sup>	10 000 cm <sup>2</sup>	1.1960 yd. <sup>2</sup>
1 hectare [ha]	10 000 m <sup>2</sup>	2.4711 acres
1 km <sup>2</sup>	100 ha	0.3861 mile <sup>2</sup>

a)  $4\frac{1}{4}$  yd.<sup>2</sup> to m<sup>2</sup> (1 mark)

Answer:

$$1 \text{ yd.}^2 = 0.8361 \text{ m}^2$$

$$4.25 \text{ yd.}^2 = 4.25 \times 0.8361 = 3.55 \text{ m}^2$$

b) 100 cm<sup>2</sup> to in.<sup>2</sup> (1 mark)

Answer:

$$1 \text{ cm}^2 = 0.155 \text{ in.}^2$$

$$100 \text{ cm}^2 = 100 \times 0.155 = 15.5 \text{ in.}^2$$

c) 640 in.<sup>2</sup> to m<sup>2</sup> (2 marks)

Answer:

144 in. <sup>2</sup>	0.0929 m <sup>2</sup>
640 in. <sup>2</sup>	$x$ m <sup>2</sup>

$$\frac{144}{640} = \frac{0.0929}{x}$$

$$144x = (640)(0.0929)$$

$$144x = 59.456$$

$$\frac{144x}{144} = \frac{59.456}{144}$$

$$x = 0.41$$

Thus, 640 in.<sup>2</sup> = 0.41 m<sup>2</sup>.

d) 102 square miles to  $\text{km}^2$  (1 mark)

*Answer:*

$$1 \text{ mile}^2 = 2.59 \text{ km}^2$$

$$102 \text{ mile}^2 = 102 \times 2.59 = 264.18 \text{ km}^2$$

e) 4000  $\text{cm}^2$  to  $\text{ft}^2$  (4 marks)

*Answer:*

$$1 \text{ cm}^2 = 0.155 \text{ in.}^2$$

$$4000 \text{ cm}^2 = 4000 \times 0.155 = 620 \text{ in.}^2$$

$$1 \text{ ft.}^2 = 144 \text{ in.}^2$$

$$x \text{ sq. ft.} = 620 \text{ sq. in.}$$

$$\frac{1}{x} = \frac{144}{620}$$

$$144x = 620$$

$$\frac{144x}{144} = \frac{620}{144}$$

$$x = 4.31$$

Thus,  $4000 \text{ cm}^2 = 4.31 \text{ sq. ft.}$

23. Multiply these fractions using the grid method. Write your answer as a mixed number.  
(2 marks) (Module 4, Lesson 1)

$$1\frac{3}{4} \times 7\frac{1}{2}$$

Answer:

		7	$\frac{1}{2}$
1		$1 \times 7 = 7$	$1 \times \frac{1}{2} = \frac{1}{2}$
$\frac{3}{4}$		$\frac{3}{4} \times 7 = \frac{21}{4}$	$\frac{3}{4} \times \frac{1}{2} = \frac{3}{8}$

$$1\frac{3}{4} \times 7\frac{1}{2} = 7 + \frac{1}{2} + \frac{21}{4} + \frac{3}{8} = 7 + \frac{4}{8} + \frac{42}{8} + \frac{3}{8} = 7 + \frac{49}{8} = 7 + 6\frac{1}{8} = 13\frac{1}{8}$$

24. The cost of the new football stadium is predicted to be \$137,500,000. Write this number in scientific notation. (1 mark) (Module 3, Lesson 1)

Answer:

$$\$1.375 \times 10^8$$

25. Madeline works in a bakery. She makes a minimum wage of \$9.25 per hour but has been offered a raise to \$10.05. What percent rate of increase is this? Round off to two decimal places. (2 marks) (Module 1, Lesson 2)

*Answer:*

$$\text{Percent rate of increase} = \frac{\text{amount of change}}{\text{original value}} \times 100$$

$$\text{Percent increase in wage} = \frac{(\$10.05 - \$9.25)}{\$9.25} \times 100 = \frac{\$0.80}{\$9.25} \times 100 = 8.65\%$$

**Remember: Attach your Midterm Exam Resource Sheet to your exam paper and submit it along with your exam.**

---

## Notes