



GRADE 10 ESSENTIAL
MATHEMATICS (20S)

Final Practice Exam
Answer Key

GRADE 10 ESSENTIAL MATHEMATICS

Final Practice Examination Answer Key

Name: _____

Student Number: _____

Attending Non-Attending

Phone Number: _____

Address: _____

For Marker's Use Only

Date: _____

Final Mark _____ /100 = _____ %

Comments: _____

Instructions

The final examination will be weighted as follows:

Modules 5–8 100%

The format of the examination will be as follows:

Part A: Multiple Choice 10 marks

Part B: Long Answer 90 marks

Time allowed: 2.5 hours

Note: You are allowed to bring the following to the exam: pens/pencils (2 or 3 or each), blank paper, a scientific calculator, a ruler, a protractor, a compass, and your Final Exam Resource Sheet. Your Final Exam Resource Sheet must be handed in with the exam.

Part A: Multiple Choice ($10 \times 1 = 10$ marks)

Circle the letter of the correct answer for each question.

1. $\cos 55^\circ =$

- a) 1.42814
- b) 0.57358
- c) 0.81915
- d) 0.022126

Module 7, Lesson 6

2. If $\cos \theta = 0.6691306$, then $\theta =$

- a) 48°
- b) 42°
- c) 33.8°
- d) 22.9°

Module 7, Lesson 6

3. If $\triangle ABC \sim \triangle PQR$, then

- a) $AB = PQ$
- b) $\angle A = \angle P$
- c) $a = b$
- d) $c = r$

Module 7, Lesson 2

Note: AB corresponds to PQ but is not equal to it. Side c corresponds to side r but is not equal to it.

4. The cost of 4 L of milk is \$7.35. The unit cost per litre is

- a) \$3.68
- b) \$1.84
- c) \$2.45
- d) \$0.735

Module 6, Lesson 1

5. A 10% discount off an item priced at \$30.00 would save you

- a) \$3.00
- b) \$27.00
- c) \$10.00
- d) \$1.00

Module 6, Lesson 3

6. The currency widely used across Europe is

- a) US dollar
- b) Japanese yen
- c) Euro
- d) Peso

Module 6, Lesson 6

7. A reflection of a shape is

- a) larger than the original
- b) smaller than the original
- c) distorted
- d) a mirror image

Module 8, Lesson 3

8. A rotation of a shape is

- a) a slide
- b) a translation
- c) a turn
- d) a mirror image

Module 8, Lesson 2

9. Which statement is true about angles with parallel lines with a transversal?

- a) All angles are 60°
- b) Interior alternate angles are complementary
- c) Corresponding angles are supplementary
- d) Exterior alternate angles are congruent

Module 5, Lesson 5

10. If two lines are perpendicular, they

- a) meet at a right angle
- b) are always the same distance apart
- c) never meet
- d) are supplementary

Module 5, Lesson 4

Part B: Long Answer (90 marks)

Write your answers in the space provided.

1. Explain what a right angle is. (1 mark) Module 5, Lesson 1

Answer:

An angle whose measure is exactly 90° .

2. Draw an example of two angles that are supplementary but do not have the same vertex. (1 mark) Module 5, Lesson 4

Answer:

Any two angles whose sum is 180° are acceptable.

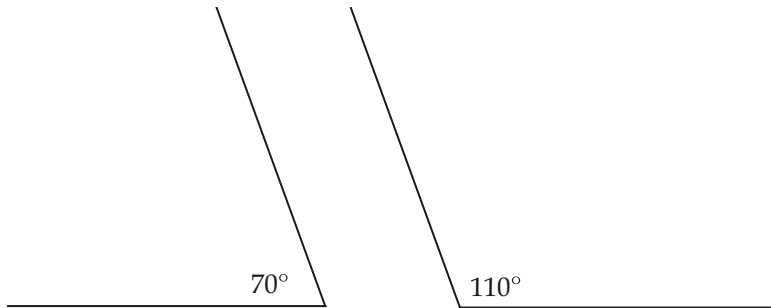

3. Use any method to copy the angle shown below, and describe the process you used. (4 marks) Module 5, Lesson 3

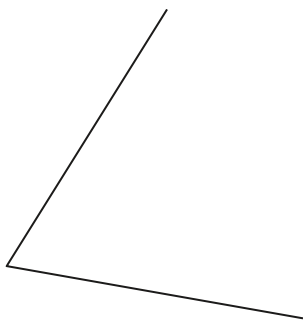

Answer:

Answers may vary.

Angle must be exact within 3° and approximate size is 68° .

Descriptions could include protractor, folding, tracing, or compass.

4. Use any method to bisect this angle, and describe the process you used. (4 marks) Module 5, Lesson 3

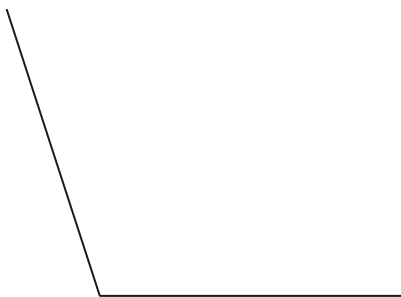

Answer:

Answers may vary.

Angle must be bisected within 3° and each angle is approximately 54° .

Descriptions could include protractor, folding, tracing, or compass.

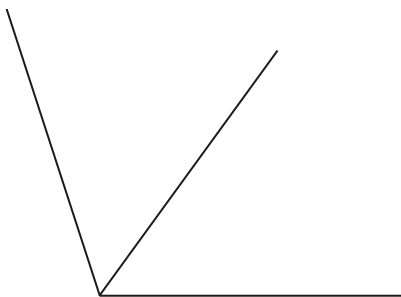

5. Given $\angle 1$ and $\angle 3$ are congruent, explain why $EF \parallel GH$. (2 marks) Module 5, Lesson 6

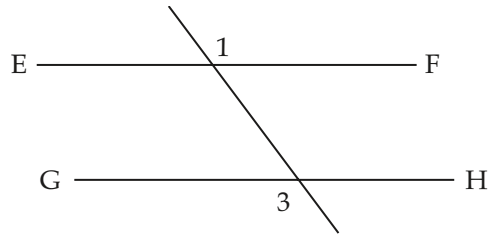

Answer:

$\angle 1$ and $\angle 3$ are exterior alternate angles. Since they are equal, then the lines must be parallel.

6. Identify any four pairs of equal angles and give a reason why they are equal. You are given $JK \parallel LM$. (4 marks) Module 5, Lesson 5

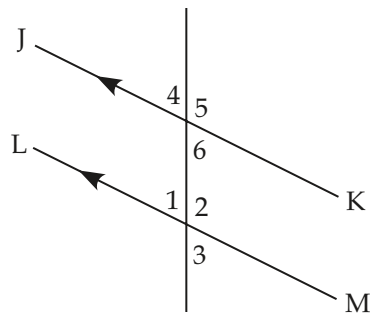

Answer:

Answers may vary. Any four of the following:

- $\angle 1 = \angle 3$ vertically opposite angles
- $\angle 1 = \angle 4$ corresponding angles
- $\angle 1 = \angle 6$ interior alternate angles
- $\angle 2 = \angle 5$ corresponding angles
- $\angle 3 = \angle 4$ exterior alternate angles
- $\angle 3 = \angle 6$ corresponding angles
- $\angle 4 = \angle 6$ vertically opposite angles

7. Your new wage is \$10.90 per hour. You were making \$10.75 per hour. Find the percent rate of change. (3 marks) Module 6, Lesson 4

Answer:

$$\text{Percent rate of change} = \frac{\text{amount of change}}{\text{original value}} \times 100$$

$$\text{Percent rate of change} = \frac{0.15}{10.75} \times 100 = 1.4\%$$

8. Your job in the restaurant pays you \$11.32 per hour. Your boss offers you either a 3% raise, or \$0.35 per hour raise. Which is the better offer? Explain your reasoning. (3 marks) Module 6, Lesson 4

Answer:

Percent raise

$$\$11.32 \times 1.03 = \$11.66$$

Money raise

$$\$11.32 + 0.35 = \$11.67$$

The \$0.35 increase is better.

Students may choose to convert the % increase into dollars.

$$0.03 \times \$11.32 = \$0.34$$

9. Apple juice is sold in packages of various sizes.
 a) Find the unit price per 100 mL to determine the best buy. (3 marks)

- i) 350 mL for \$1.05
 ii) 1 L for \$3.15
 iii) 2 L for \$5.95

Module 6, Lesson 1

Answer:

- i) 350 mL for \$1.05

350 mL	\$1.05
100 mL	\$x

$$\frac{350}{100} = \frac{1.05}{x}$$

$$350x = 105$$

$$\frac{350x}{350} = \frac{105}{350}$$

$$x = 0.3$$

Therefore, unit price = \$0.30 per 100 mL.

- ii) 1 L for \$3.15
 1 litre = 1000 mL

1000 mL	\$3.15
100 mL	\$x

$$\frac{1000}{100} = \frac{3.15}{x}$$

$$1000x = 315$$

$$\frac{1000x}{1000} = \frac{315}{1000}$$

$$x = 0.315$$

Therefore, unit price = \$0.32 per 100 mL.

iii) 2 L for \$5.95

1 litre = 1000 mL

2 L = 2 × 1000 = 2000 mL

2000 mL	\$5.95
100 mL	\$x

$$\frac{2000}{100} = \frac{5.95}{x}$$

$$2000x = 595$$

$$\frac{2000x}{2000} = \frac{595}{2000}$$

$$x = 0.2975$$

Therefore, unit price = \$0.30 per 100 mL.

Either the 350 mL or the 2 L size would be the better buy, although the 2 L is \$0.0025 cheaper if you use all the decimal points.

b) Give one reason why a person might want a smaller size, knowing it costs more.

(1 mark) Module 6, Lesson 1

Answer:

Answers will vary.

Not enough money, not that thirsty, larger size might spoil, no storage room, distance from store

10. Dane needs a new washer and dryer set, and the set he wants will cost \$1345. Southdale Department Store has a promotion on where the store will pay the taxes. Charles' is having a 10% off all appliances sale. The Lighte has a 15% off sale on all appliances. Module 6, Lesson 5

a) Which is the best buy? (4 marks)

Answer:

Southdale

Total Cost: \$1345

Charles'

Cost with Discount, No Taxes: $(1 - 0.10) \times 1345 = \1210.50

PST: $0.07 \times 1210.50 = \$84.74$

GST: $0.05 \times 1210.50 = \$60.53$

Total Including Taxes: $\$1350 + \$84.74 + \$60.53 = \1355.77

The Lighte

15% off: $(1 - 0.15) \times \$1345 = \1143.25

PST: $0.07 \times \$1143.25 = \80.03

GST: $0.05 \times \$1143.25 = \57.17

Total: $\$1143.25 + \$80.03 + \$57.17 = \1280.45

b) State two other types of promotions that stores use. (2 marks)

Answer:

Answers may vary. Responses may include the following:

- no taxes
- loyalty cards
- % discounts
- \$ discounts
- package deals

c) State two reasons why you would choose to go to a store with more expensive prices. (2 marks)

Answer:

Answers may vary. Responses may include:

- time to get to the store
- cost of gas/amount of gas to get there
- rewards/loyalty cards

11. Griffen was planning a trip to Mexico and the southern United States. He budgeted for 18 200 pesos and \$850 American dollars.
- a) Use the Currency Converter Chart to find the cost of obtaining these currencies from a bank. (3 marks) Module 6, Lesson 6

Currency Converter as of February, 2009		
	Bank's Selling Rate	Bank's Buying Rate
Canadian Dollar	1	1
Mexican Peso	0.0909	00.0794
American Dollar	1.2634	1.2106

Answer:

Griffen is buying currency from the bank, so he needs to use the bank's selling rates.

Pesos

$$1 \text{ Peso} = \$1.6345 \text{ Canadian}$$

$$18\,200 \text{ pesos} = 18\,200 \times \$0.0909 = \$1654.38$$

US dollars

$$1 \text{ US dollar} = \$1.2634 \text{ Canadian}$$

$$850 \text{ US dollars} = 850 \times \$1.2634 = \$1073.89$$

$$\text{Total} = \$1654.38 + \$1073.89 = \$2727.27$$

- b) Upon his return, Griffen had 1425 pesos and \$52 American dollars to return to the bank. How much did he receive for this exchange? (3 marks) Module 6, Lesson 6

Answer:

Griffen is selling currency to the bank, so he needs to use the bank's buying rates.

Euro

$$1 \text{ Peso} = \$0.0794 \text{ Canadian}$$

$$1425 \text{ pesos} = 1425 \times \$0.0794 = \$113.15$$

US dollars

$$1 \text{ US dollar} = \$1.2106 \text{ Canadian}$$

$$52 \text{ US dollars} = 52 \times \$1.2106 = \$62.95$$

$$\text{Total refund} = \$113.15 + \$62.95 = \$176.10$$

12. You have \$730 Canadian for a trip to Grand Forks. How much US currency can you get from the bank? Use the Currency Converter chart in #11 above. (2 marks)
Module 6, Lesson 6

Answer:

\$1.2634 Canadian	\$1 US
\$730 Canadian	\$x US

$$\frac{1.2634}{730} = \frac{1}{x}$$

$$1.2634x = 730$$

$$\frac{1.2634x}{1.2634} = \frac{730}{1.2634}$$

$$x = 577.81$$

Therefore, you can buy \$577.81 US from the bank.

13. Given two similar triangles, $\triangle BRD \sim \triangle JAM$, as shown in the diagram below, find the length of m and the measure of $\angle R$. (4 marks) Module 7, Lesson 2

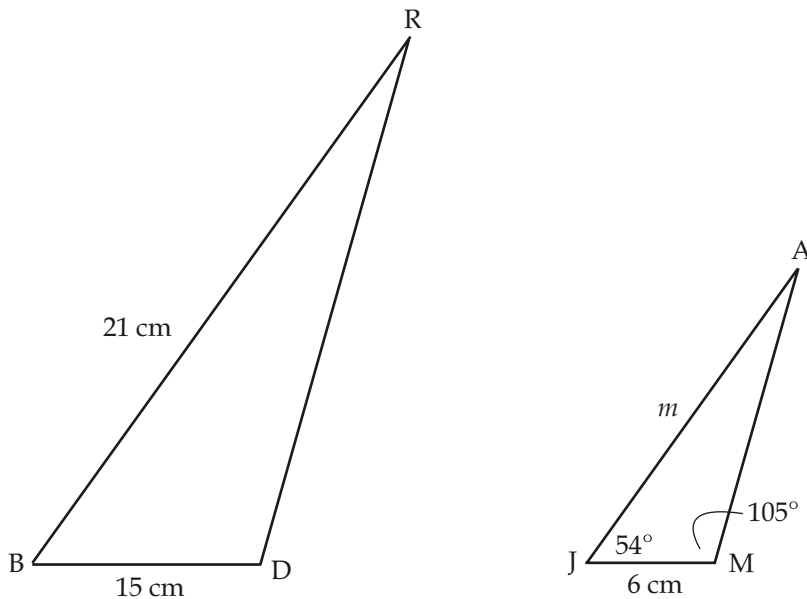

Answer:

From the similarity relationship, $\triangle BRD \sim \triangle JAM$, the chart can be made.

	$\angle B = \angle J = 54^\circ$	$\angle R = \angle A = ?$	$\angle D = \angle M = 105^\circ$
$\triangle BRD$	$b = ?$	$r = 15 \text{ cm}$	$d = 21 \text{ cm}$
$\triangle JAM$	$j = ?$	$a = 6 \text{ cm}$	$m = ?$

$$\frac{r}{a} = \frac{d}{m}$$

$$\frac{15}{6} = \frac{21}{m}$$

$$15m = (6)(21)$$

$$15m = 126$$

$$\frac{15m}{15} = \frac{126}{15}$$

$$m = 8.4$$

The length of m is 8.4 cm.

To find the measure of $\angle R$, use the fact that the sum of the angles in a triangle = 180° .

Since $\triangle BRD \sim \triangle JAM$, then $\angle B = \angle J = 54^\circ$ and $\angle D = \angle M = 105^\circ$.

Thus, $\angle R = 180^\circ - (54^\circ + 105^\circ) = 180^\circ - 159^\circ = 21^\circ$.

The length of m is 8.4 cm.

The measure of $\angle R$ is 21° .

14. Find the length of the missing side. Round off to two decimal places. (3 marks)
Module 7, Lesson 3

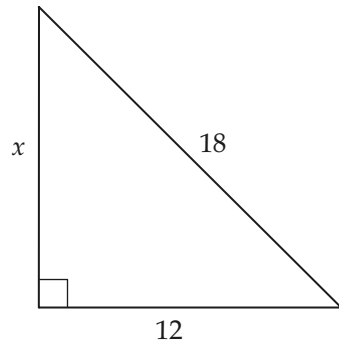

Answer:

$$a^2 + b^2 = c^2$$

$$x^2 + 12^2 = 18^2$$

$$x^2 + 144 = 324$$

$$x^2 = 180$$

$$x = 13.42$$

15. Determine the length of the missing side using a trigonometric ratio. Round off to two decimal places. (3 marks) Module 6, Lesson 6

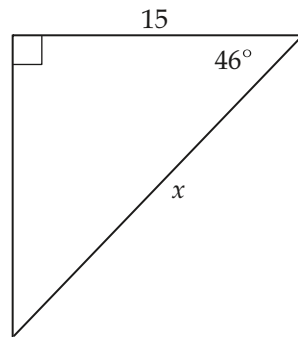

Answer:

$$\cos 46^\circ = \frac{15}{x}$$

$$x = \frac{15}{\cos 46^\circ}$$

$$x = 21.59$$

16. A cell phone tower is held in place by a cable 20 m long. The base of the cable is 14 m away from the base of the tower. Determine the height of the tower. (4 marks)

Module 7, Lesson 3

Answer:

$$a^2 + b^2 = c^2$$

$$x^2 + 14^2 = 20^2$$

$$x^2 + 196 = 400$$

$$x^2 = 204$$

$$x = 14.3 \text{ m}$$

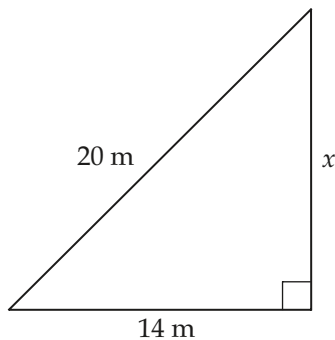

17. Find the missing side. Round off to two decimal places. (3 marks)

Module 7, Lesson 4

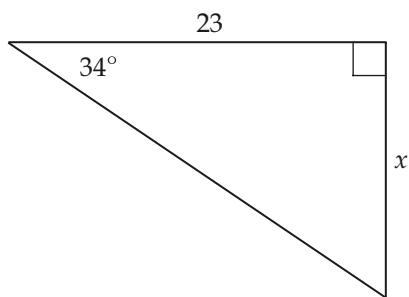

Answer:

$$\tan 34^\circ = \frac{x}{23}$$

$$x = 23 \tan 34^\circ$$

$$x = 15.5$$

18. A hot air balloon is attached to a 25 m rope. The balloon is 15 m above the ground. Find the angle at which the rope is inclined to the ground. Draw the diagram, set up the appropriate trig ratio, and solve for θ . Round off to two decimal places. (5 marks)
Module 7, Lesson 7

Answer:

$$\sin \theta = \frac{15}{25}$$

$$\theta = \sin^{-1}\left(\frac{15}{25}\right)$$

$$\theta = 36.87^\circ$$

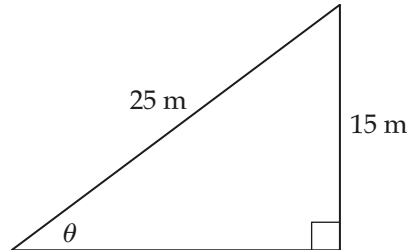

19. A meteor is racing toward Earth and will soon enter the atmosphere. The meteor is above the top of a hill 22 miles away from where you are. You look upward 16 miles to see the meteor. Find the angle between the ground and your line of sight as you look towards the meteor. Draw the diagram, set up the appropriate trig ratio, and solve for θ . (5 marks) Module 7, Lesson 7

Answer:

$$\tan \theta = \frac{16}{22}$$

$$\theta = \tan^{-1}\left(\frac{16}{22}\right)$$

$$\theta = 36^\circ$$

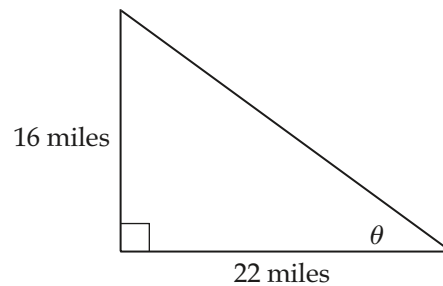

20. Draw the translation of the following shape, applying the rule $[L2, D4]$, and label the points of the image. (4 marks) Module 8, Lesson 1

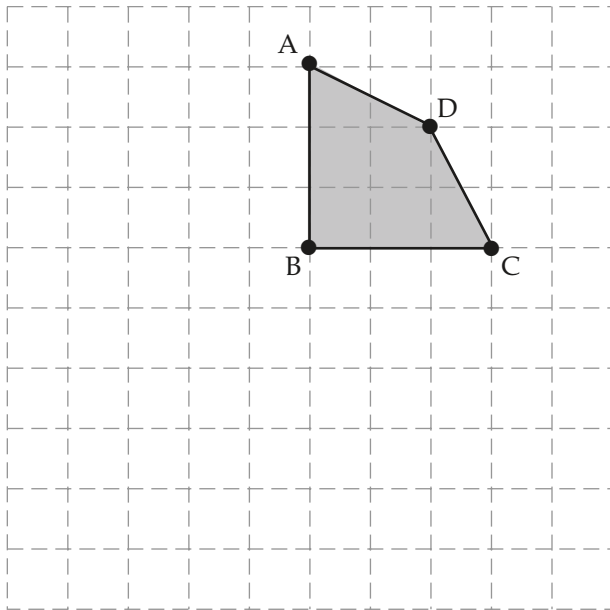

Answer:

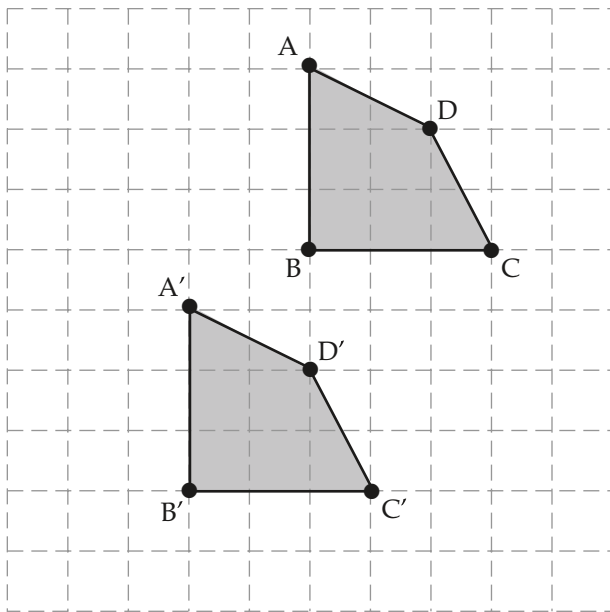

21. Identify the translation used. Write your answer in words. (2 marks)
Module 8, Lesson 1

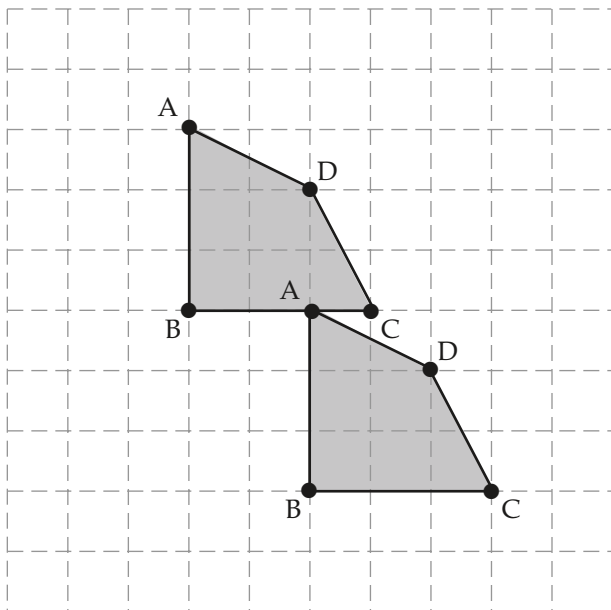

Answer:

Rule: [R2, D3]

Words: Right 2 units, down 3 units

22. Draw the reflection of this shape over the x -axis, and label the points in the image.
(4 marks) Module 8, Lesson 3

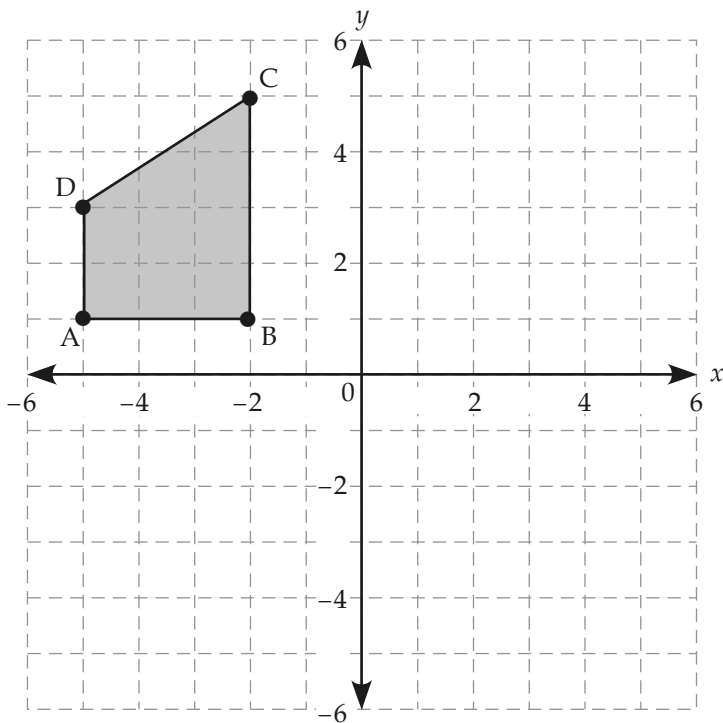

Answer:

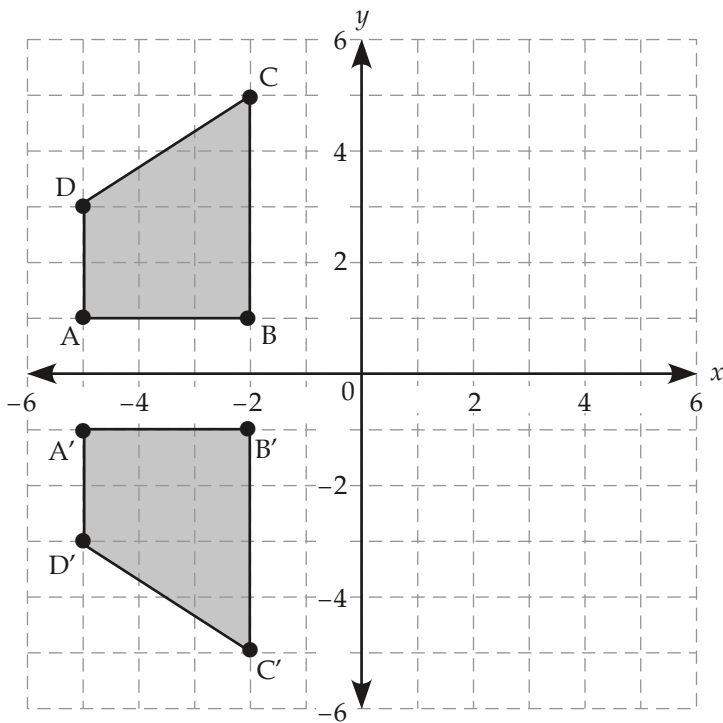

23. Rotate the shape 90° clockwise about point B, and draw the rotation. (3 marks)
Module 8, Lesson 2

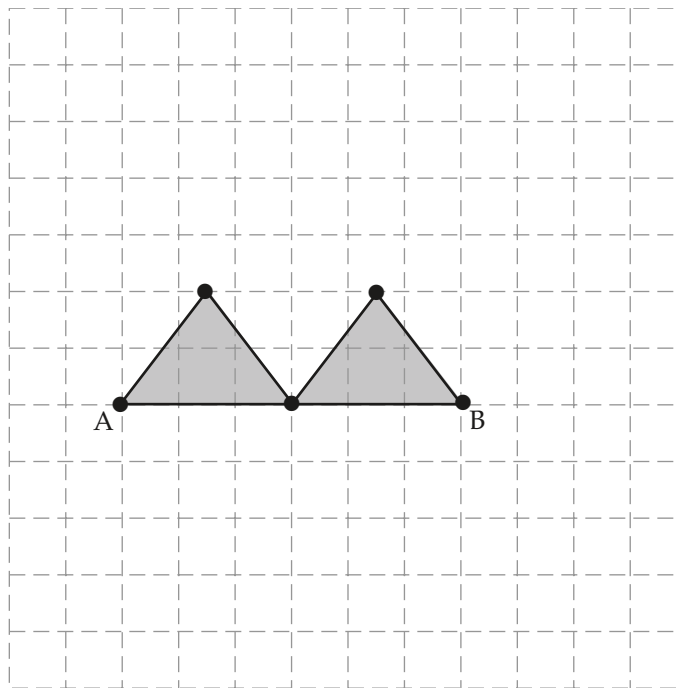

Answer:

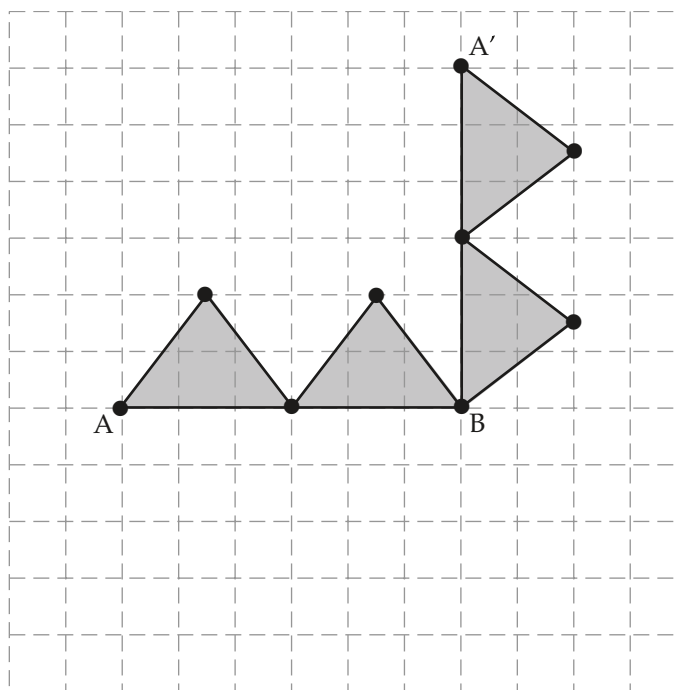

24. Draw a dilation of this shape using a scale factor of 2, with point B being the centre of the dilation. (4 marks) Module 8, Lesson 5

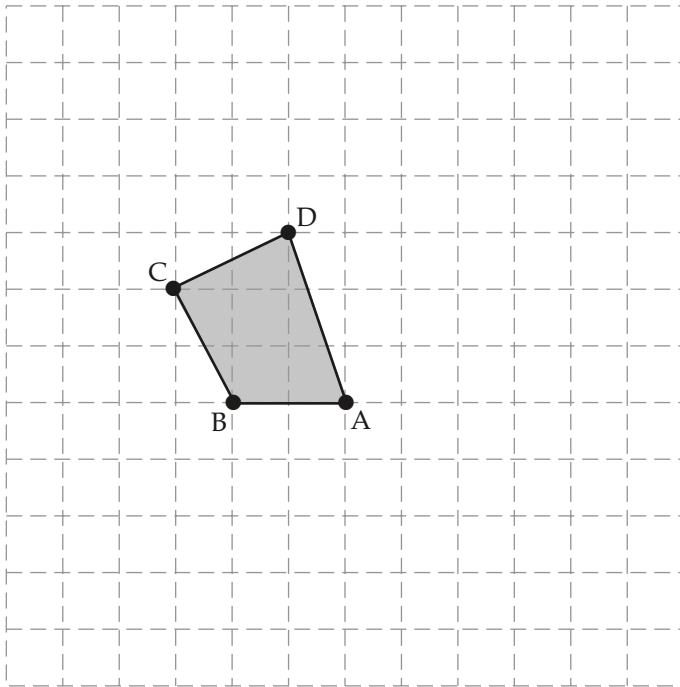

Answer:

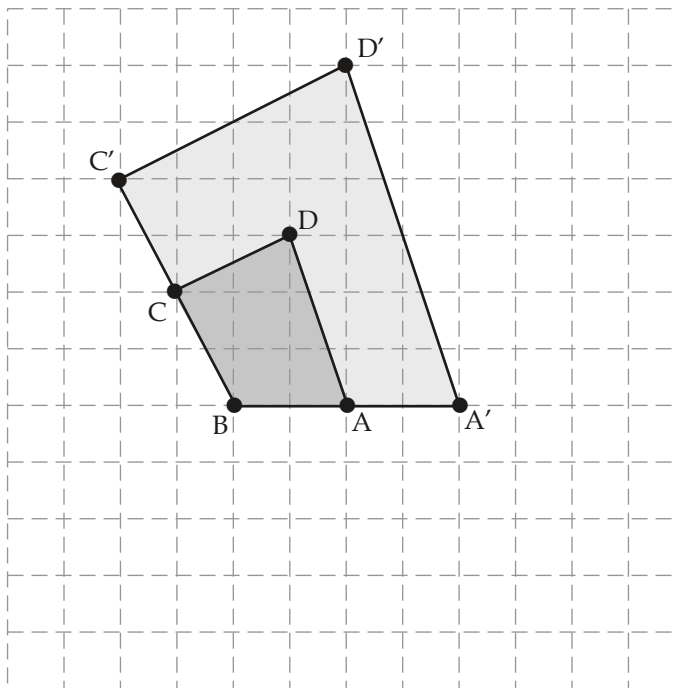

25. Identify a possible pattern of transformations used to create this shape, starting with rectangle ABCD. Each successive transformation is performed to the previous image. (4 marks) Module 8, Lesson 4

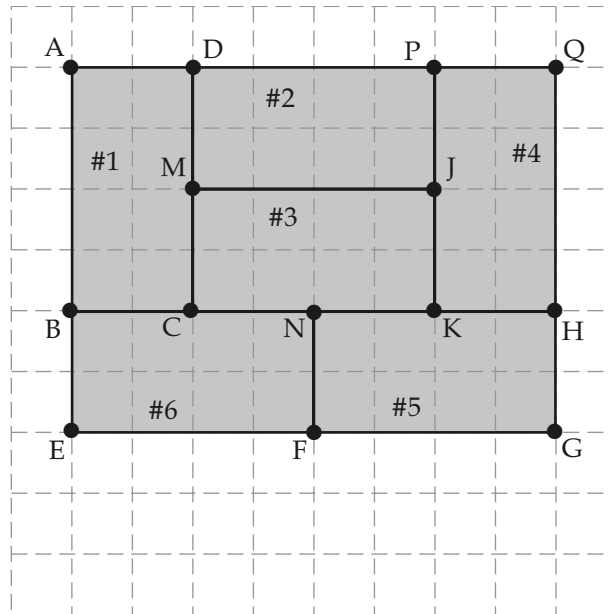

Answer:

Answers will vary, any methods that would work are acceptable.

Rotate #1 90° CCW about point D, to make #2.

Translate #2 [R0, D2] to make #3.

Rotate #3 90° CW about point K to make #4.

Rotate #4 90° CCW about H to make #5.

Translate #5 [R4, D0] to make #6.

Remember: Attach your Final Exam Resource Sheet to your exam paper and submit it along with your exam.

Notes