

GRADE 10 INTRODUCTION TO
APPLIED AND PRE-CALCULUS
MATHEMATICS (20S)

Final Practice Exam

GRADE 10 INTRODUCTION TO APPLIED
AND PRE-CALCULUS MATHEMATICS

Final Practice Exam

Name: _____

Student Number: _____

Attending Non-Attending

Phone Number: _____

Address: _____

For Marker's Use Only

Date: _____

Final Mark: _____ /100 = _____ %

Comments:

Instructions

The final examination will be weighted as follows:

Modules 1-8	100%
-------------	------

The format of the examination will be as follows:

Part A: Multiple Choice	30 marks
Part B: Definitions	10 marks
Part C: Graphs and Relations	5 marks
Part D: Measurement	5 marks
Part E: Trigonometry	3 marks
Part F: Relations and Functions	9 marks
Part G: Polynomials	14 marks
Part H: Coordinate Geometry	20 marks
Part I: Systems	4 marks

Time allowed: 2.5 hours

Note: You are allowed to bring a scientific calculator and your Resource Sheet to the exam. Your Resource Sheet must be handed in with the exam.

Part A: Multiple Choice (30 x 1 = 30 marks)

Circle the letter of the correct answer for each question.

1. Calculate the $\frac{\text{rise}}{\text{run}}$ of this line.

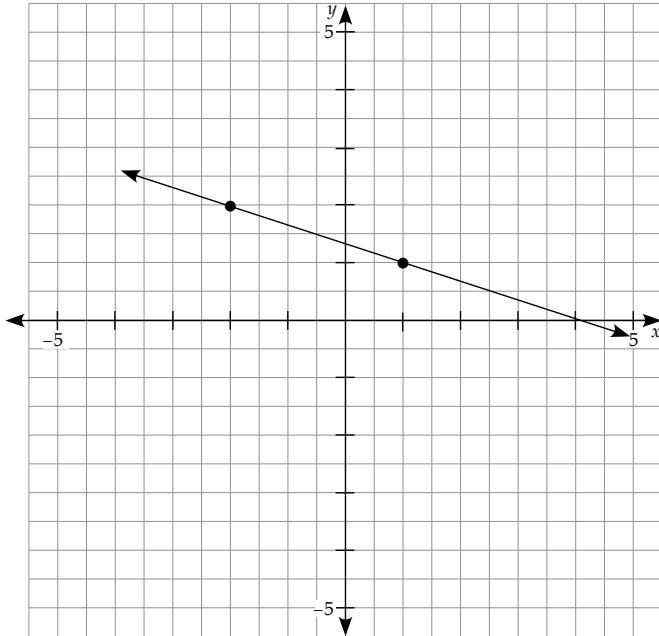

- a) $\frac{1}{3}$
- b) $\frac{3}{1}$
- c) $\frac{-1}{3}$
- d) $\frac{-3}{1}$
2. The x - and y -intercepts of the linear relation $3x + 5y - 15 = 0$ are at
- a) $(3, 0), (0, 5)$
- b) $(5, 0), (0, 3)$
- c) $(-3, 0), (0, -5)$
- d) $(0, 0), (0, 0)$

3. The graph of a linear relation has a slope of 2 and goes through the point $(3, -5)$. Another point on the line is at
- a) $(3, -8)$
 - b) $(-11, 0)$
 - c) $(5, -3)$
 - d) $(4, -3)$
4. The slope of a horizontal line is
- a) 0
 - b) 1
 - c) -1
 - d) undefined
5. The equation of a line that is parallel to $y = 3x + 5$ is
- a) $y = -3x + 15$
 - b) $y = \frac{-1}{3}x + 5$
 - c) $y = -3x + 5$
 - d) $y = 3x + 15$
6. Write $\sqrt[5]{x}$ with a rational exponent.
- a) $x^{\frac{5}{1}}$
 - b) x^{-5}
 - c) $x^{\frac{1}{5}}$
 - d) $5^{\frac{1}{x}}$

7. Write $\sqrt{12}$ as a mixed radical.
- a) $4\sqrt{3}$
 - b) $2\sqrt{3}$
 - c) $3\sqrt{2}$
 - d) $3\sqrt{4}$
8. Simplify $(3m^4n)(2m^5n)$.
- a) $5m^9n$
 - b) $6m^9n$
 - c) $6m^{20}n^2$
 - d) $6m^9n^2$
9. The least common multiple of 32 and 20 is
- a) 160
 - b) 640
 - c) 320
 - d) 4
10. Which of the following is a perfect cube number?
- a) 324
 - b) 343
 - c) 333
 - d) 361
11. Convert 147 m to inches.
- a) 186.37"
 - b) 3.73"
 - c) 14700"
 - d) 5787"

12. A pool is 6 m long and 4 m wide. If it is filled to a depth of 80 cm, how many cubic metres of water are required?
- a) 1920 m^3
 - b) 19.2 m^3
 - c) 7077.888 m^3
 - d) 192 m^3
13. The volume of a sphere is 87 cm^3 . Calculate the radius of the sphere.
- a) 20.8 cm
 - b) 2.7 cm
 - c) 4.6 cm
 - d) 5.9 cm
14. The volume of a cone is 30 m^3 . What is the volume of a cylinder with the same base and height?
- a) 10 m^3
 - b) 30 m^3
 - c) 90 m^3
 - d) 900 m^3
15. The width of a child's pinky finger could be used as a referent for
- a) 1 mm
 - b) 1 m
 - c) 1 inch
 - d) 1 cm

16. Solve for x .

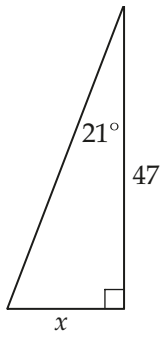

- a) 122.4
- b) 18.0
- c) 19.1
- d) 43.9

17. Solve for the measure of $\angle B$.

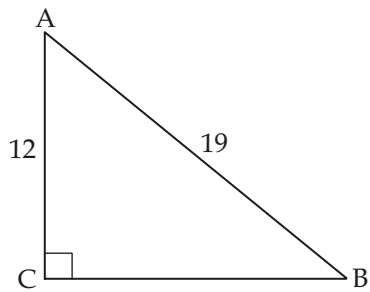

- a) 32.3°
- b) 39.2°
- c) 50.8°
- d) 57.7°

18. Which of the following does not represent a function?

a)

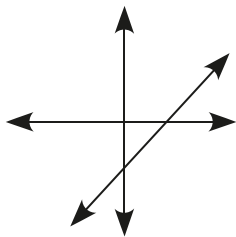

b)

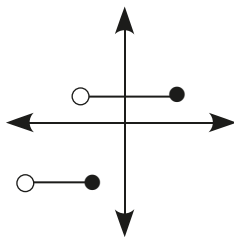

c) $\{(2, 2), (3, 2), (4, 2), (5, 2)\}$

d)

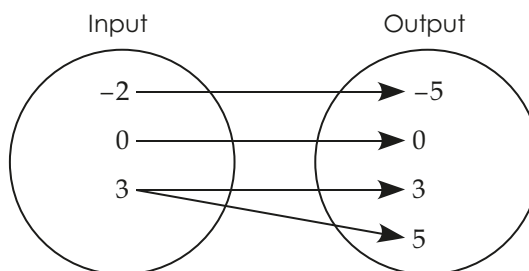

a) A

b) B

c) C

d) D

19. Given the function $f(x) = \frac{3}{2}x + 9$, find $f(4)$.

a) $\frac{-10}{3}$

b) 10.5

c) 15.0

d) 19.5

20. Multiply $4(2x + 3)$.

a) $8x + 12$

b) $8x + 3$

c) $2x + 12$

d) $24x$

21. Multiply $(x + 4)(x + 9)$.
- a) $x^2 + 13$
 - b) $2x + 13 + 36$
 - c) $x^2 + 36$
 - d) $x^2 + 13x + 36$
22. Factor $8k + 14$.
- a) $8(k + 14)$
 - b) $2(4k + 7)$
 - c) $4k(2 * 7)$
 - d) $8(k + 6)$
23. Factor $x^2 - 4x - 12$.
- a) $(x - 6)(x + 2)$
 - b) $(x + 6)(x - 2)$
 - c) $(x - 6)(x - 2)$
 - d) $(x + 6)(x + 2)$
24. Factor $x^2 - 25$.
- a) $(x - 5)(x - 5)$
 - b) $(x + 5)(x + 5)$
 - c) $(x - 5)^2$
 - d) $(x + 5)(x - 5)$
25. Calculate the distance between the coordinate points $(13, 5)$ and $(-17, -9)$.
- a) 33.1
 - b) 5.7
 - c) 26.5
 - d) 11.3

26. Calculate the coordinates of the midpoint of the line segment with endpoints at $(-15, 9)$ and $(7, -11)$.
- a) $(-11, 10)$
 - b) $(11, -1)$
 - c) $(4, 1)$
 - d) $(-4, -1)$
27. Write the equation of this line in slope-intercept form.

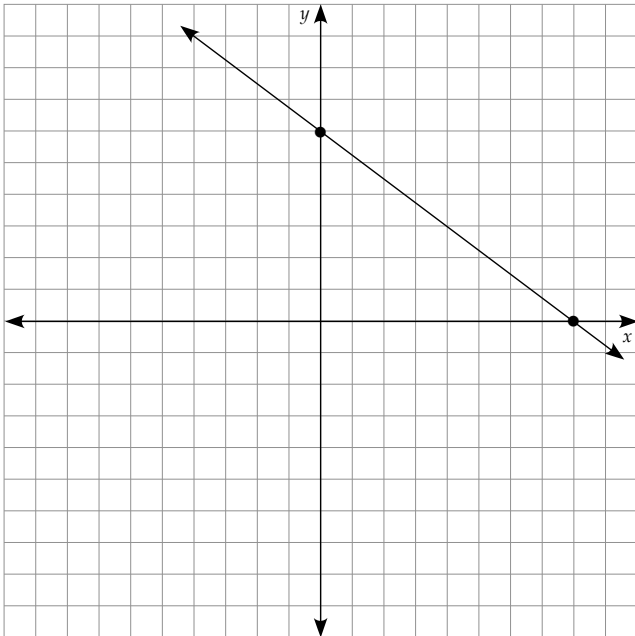

- a) $y = \frac{3}{4}x + 6$
- b) $y = \frac{4}{3}x + 8$
- c) $y = \frac{-3}{4}x + 6$
- d) $y = \frac{-3}{4}x + 8$

28. The correlation of this data is best described as

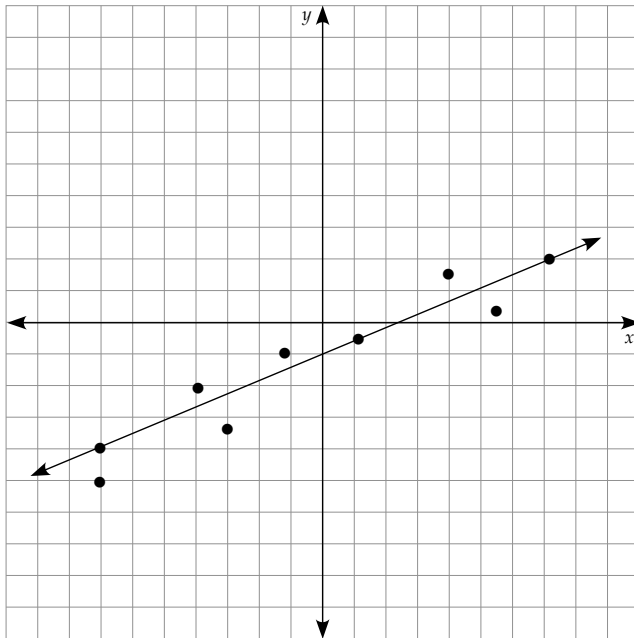

- a) strong negative
- b) weak negative
- c) weak positive
- d) strong positive

29. Three of the following linear relations are equivalent. Circle the one relation that is not equivalent to the others.

- a) $2x - y + 5 = 0$
- b) $y - 11 = 2(x - 3)$
- c) $y = 5x + 2$
- d) $3y - 6x = 15$

30. Which ordered pair is the solution to the given system of linear equations?

$$x - 5y = -15 \quad \text{Equation 1}$$

$$4x + 10y = -30 \quad \text{Equation 2}$$

- a) $(-5, -1)$
- b) $(-5, 2)$
- c) $(5, -5)$
- d) $(-10, 1)$

Part B: Definitions ($10 \times 1 = 10$ marks)

Match each definition with the correct term or symbol from the list below. Write the correct term or symbol on the blank line with each definition. Terms are used only once. Not all terms have a definition provided.

Terms

$^{\circ}$	domain	negative correlation	simplify
$>$	equation	ordered pair	slope-intercept form
$<$	function	parallel lines	slope-point form
$()$	general form	perpendicular lines	solution
\cdot	inconsistent system	polynomial	strong correlation
\geq	independent system	positive correlation	system of linear
\leq	like terms	range	equations
$[]$	linear relation	relation	table of values
\emptyset	mapping	rule	trinomial
binomial	monomial	scatterplot	weak correlation
Cartesian plane			zero correlation
coefficient			
consistent system			
constant			
correlation coefficient			
degree			
dependent system			

1. A graphic similar to a table of values that has arrows showing which input results in a given output. _____
2. If, as the x -variable increases in value, the y -variable also increases the data displays a _____.
3. The equations in this linear system represent the same line. _____
4. The coordinate system formed by a horizontal axis and a vertical axis in which a pair of numbers represents each point in the plane. _____
5. A mathematical expression with one or more terms. _____
6. $r = 0$ _____
7. The highest exponent in the leading term of the polynomial, when terms are written in descending order. _____
8. A set of two numbers named in a specific order so that the first number represents the domain value and the second number represents the range value. _____
9. Any set of ordered pairs. _____
10. Goes to and includes. _____

Part C: Graphs and Relations (5 marks)

Show all calculations and formulas used for short and long answer questions. Use all decimal places in your calculations, and round the final answers to the correct number of decimal places. Include units when appropriate. Clearly state your final answer.

1. The following table shows the number of fatal accidents per 10 000 000 aircraft departures for U. S. airlines for the 10 years from 1977 to 1986.

Year	1977	1978	1979	1980	1981	1982	1983	1984	1985	1986
Fatal Accidents per 10 000 000	6.1	10.0	7.4	0.0	7.7	6.0	7.9	1.8	6.9	1.6

- a) Create a scatterplot of this data. Include labels, units, and a title. (3 marks)

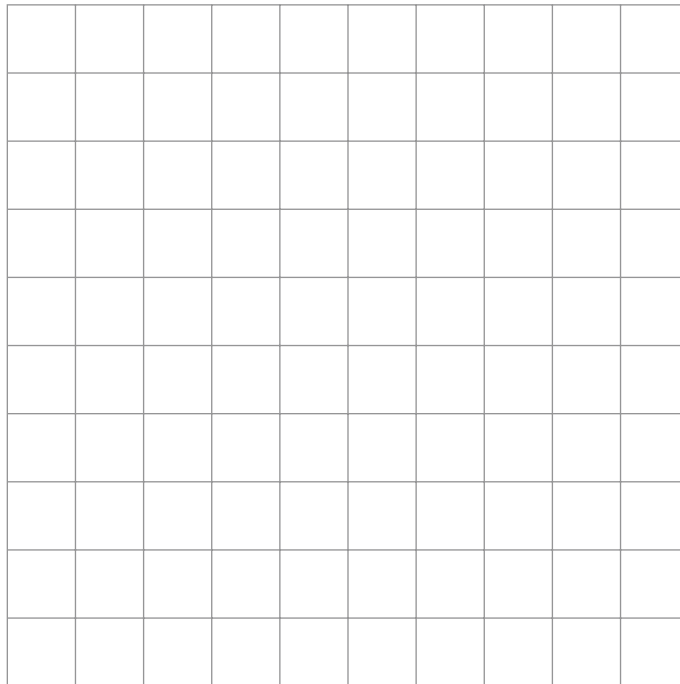

2. a) Sketch and label a graph that could represent the length of time spent waiting in line to get into the hockey arena and the number of people in line ahead of you. (1 mark)

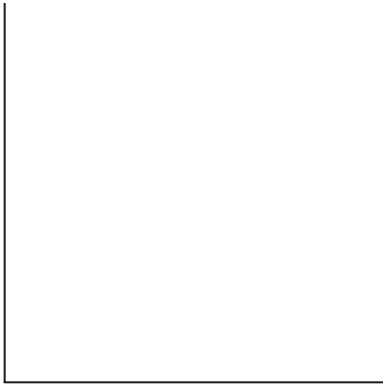

- b) State a reasonable domain and range for this situation. Explain. (1 mark)

Part D: Measurement (5 marks)

Show all calculations and formulas used for short and long answer questions. Use all decimal places in your calculations, and round the final answers to the correct number of decimal places. Include units when appropriate. Clearly state your final answer.

1. A birdhouse with a square base has a peaked roof as illustrated below. The total height of the birdhouse is 38 cm. Calculate the amount of space inside the birdhouse to the nearest cm^3 . (5 marks)

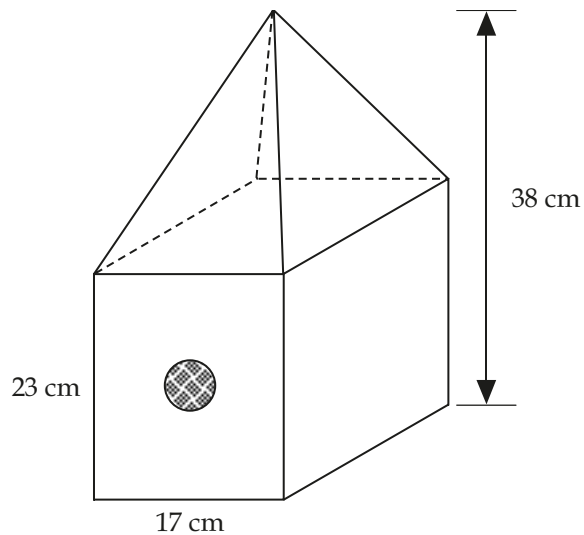

Part E: Trigonometry (3 marks)

Show all calculations and formulas used for short and long answer questions. Use all decimal places in your calculations, and round the final answers to the correct number of decimal places. Include units when appropriate. Clearly state your final answer.

1. Solve for the length of side x . (3 marks)

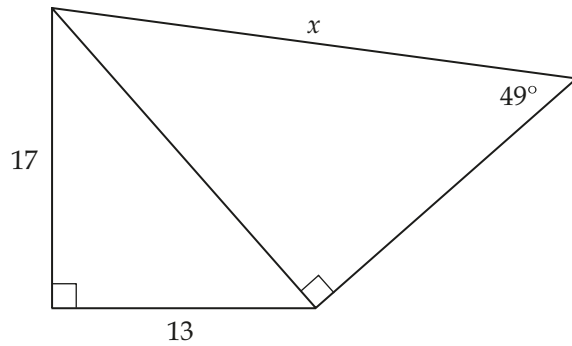

Part F: Relations and Functions (9 marks)

Show all calculations and formulas used for short and long answer questions. Use all decimal places in your calculations, and round the final answers to the correct number of decimal places. Include units when appropriate. Clearly state your final answer.

1. State the domain and range of the following relations in both set and interval notation. (4 marks)

a)

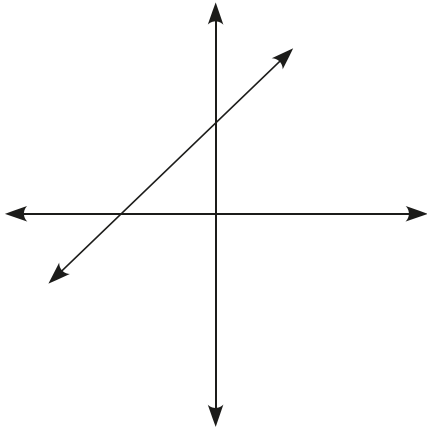

b)

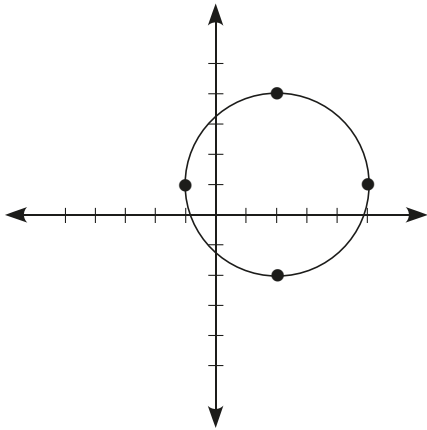

2. Given the linear equation $2x - 3y - 15 = 0$

a) Express the linear equation in functional notation. (2 marks)

b) Sketch the linear function. (1 mark)

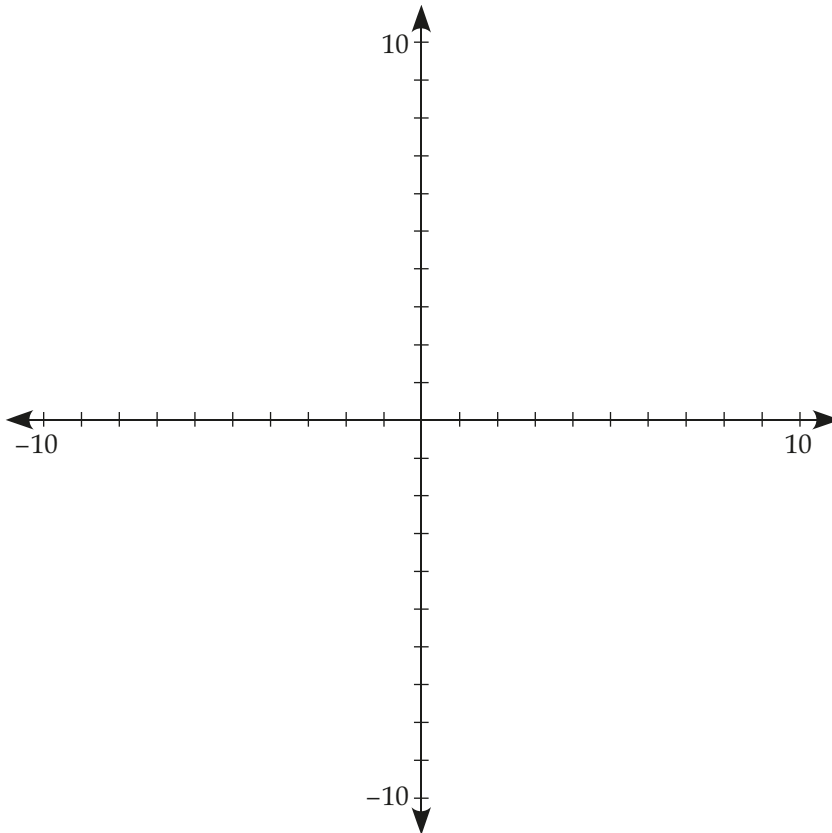

3. Explain how you can determine whether or not a given set of ordered pairs represents a function. (2 marks)

Part G: Polynomials (14 marks)

Show all calculations and formulas used for short and long answer questions. Use all decimal places in your calculations, and round the final answers to the correct number of decimal places. Include units when appropriate. Clearly state your final answer.

1. Represent the product of $(2x + 3)(x + 4)$ pictorially. State the simplified solution.
(4 marks)

2. Multiply and simplify the solution.

a) $(x - 3)(3x + 5)$ (3 marks)

b) $(5x + 4)(2x - 3)$ (3 marks)

3. Factor completely. Verify by multiplying the factors. (4 marks)

$$2x^2 + 7x + 6$$

Part H: Coordinate Geometry (20 marks)

Show all calculations and formulas used for short and long answer questions. Use all decimal places in your calculations, and round the final answers to the correct number of decimal places. Include units when appropriate. Clearly state your final answer.

1. The centre of a circle is at (52, 34). If an endpoint of its diameter is at (61, 46), find the coordinates of the other endpoint. (3 marks)

2. Express the linear equation $y - 5 = \frac{2}{7}(x - 21)$ in slope-intercept form. (2 marks)

3. Explain a strategy for graphing a linear equation given in point-slope form. (3 marks)

4. The graph of a linear relation goes through the points (9, -11) and (13, -2). Write the equation of the linear relation in point-slope form. (3 marks)

5. The graph of a linear relation goes through the point $(6, 4)$ and is parallel to the line $y = 5x + 10$. Write the equation of the linear relation in slope-intercept form. (3 marks)
6. Determine if the triangle with vertices at $A(-5, 3)$, $B(-1, -8)$, and $C(6, -1)$ is an isosceles triangle. (6 marks)

Part I: Systems (4 marks)

Show all calculations and formulas used for short and long answer questions. Use all decimal places in your calculations, and round the final answers to the correct number of decimal places. Include units when appropriate. Clearly state your final answer.

1. Suzy has a German Shepherd and a Toy Poodle. The difference in height between them is 15". Twice the height of a poodle is still 6" shorter than a German Shepherd. Write a system of linear equations to represent this situation. Do **not** solve the system. (1 mark)

2. Solve the system of linear equations using elimination by addition or subtraction.
(3 marks)

$$3x + 2y = 4$$

$$x - y = 3$$

Notes