

GRADE 12 CHEMISTRY
FINAL — PRACTICE REVIEW TEST
FTR — 02

Name _____

Student Number _____

Attending Non-Attending

Phone Number _____

Address _____

VALUE: TOTAL 100 MARKS

Solubility Chart

ION	Group IA		NH ₄ ⁺	NO ₃ ⁻	CH ₃ COO ⁻	Cl ⁻ , Br ⁻ , I ⁻	SO ₄ ²⁻	S ²⁻	OH ⁻	PO ₄ ³⁻ , SO ₃ ²⁻ , CO ₃ ²⁻
	alkalis	H ⁺								
SOLUBLE s ≥ 0.1 mol L	all	all	all	all	all	most	most	Group IA & IIA, NH ₄ ⁺	Group IA NH ₄ ⁺ , Sr ²⁺ , Ba ²⁺	Group IA, NH ₄ ⁺
LOW SOLUBILITY s < 0.1 mol L	none	none	none	none	none	Ag ⁺ , Pb ²⁺ , Hg ⁺ , Cu ⁺	Ag ⁺ , Pb ²⁺ , Ca ²⁺ , Ba ²⁺ , Sr ²⁺	most	most	most

PART A Multiple Choice

Circle the correct answer to the following questions. (48 x 1 = 48 marks)

1. A solution containing an unknown cation was added to three solutions and the following observations were recorded:

SOLUTION	OBSERVATION
NaI	no precipitate
Na ₂ SO ₄	precipitate
NaOH	precipitate

The unknown cation is

- a) Pb²⁺
- b) Sr²⁺
- c) Ca²⁺
- d) Ag⁺

2. If the solubility of Pb(OH)_2 is 0.155 g/L, then the concentration of each ion in a saturated solution of a Pb(OH)_2 is
- $[\text{Pb}^{2+}] = 0.155 \text{ g/L}$ and $[\text{OH}^-] = 0.155 \text{ g/L}$
 - $[\text{Pb}^{2+}] = 0.052 \text{ g/L}$ and $[\text{OH}^-] = 0.103 \text{ g/L}$
 - $[\text{Pb}^{2+}] = 6.43 \times 10^{-4} \text{ M}$ and $[\text{OH}^-] = 1.29 \times 10^{-3} \text{ M}$
 - $[\text{Pb}^{2+}] = 6.43 \times 10^{-4} \text{ M}$ and $[\text{OH}^-] = 6.43 \times 10^{-4} \text{ M}$
3. The K_{sp} expression for a saturated solution of $\text{Ca}_3(\text{PO}_4)_2$ is
- $K_{sp} = [\text{Ca}^{2+}][\text{PO}_4^{3-}]$
 - $K_{sp} = [\text{Ca}^{2+}]^3[\text{PO}_4^{3-}]^2$
 - $K_{sp} = [3\text{Ca}^{2+}][2\text{PO}_4^{3-}]$
 - $K_{sp} = [3\text{Ca}^{2+}]^3[2\text{PO}_4^{3-}]^2$
4. At 25°C , the solubility of an unknown compound is $7.1 \times 10^{-5} \text{ M}$. The compound is
- CuI ($K_{sp} = 1.6 \times 10^{-16}$)
 - AgI ($K_{sp} = 8.3 \times 10^{-17}$)
 - CaCO_3 ($K_{sp} = 5.0 \times 10^{-9}$)
 - BaSO_4 ($K_{sp} = 1.5 \times 10^{-9}$)
5. When equal volumes of 0.2 M NH_4Cl and 0.2 M CuSO_4 are combined,
- a precipitate does not form
 - a precipitate of CuCl_2 forms
 - a precipitate of $(\text{NH}_4)_2\text{SO}_4$ forms
 - a precipitate of both $(\text{NH}_4)_2\text{SO}_4$ and CuCl_2 forms
6. Which of the following describes the changes in ion concentrations when 1.0 g of solid ZnS is added to a saturated solution of ZnS ?

	$[\text{Zn}^{2+}]$	$[\text{S}^{2-}]$
a)	increases	decreases
b)	decreases	decreases
c)	increases	increases
d)	remains constant	remains constant

7. Consider the following graph for a saturated Ag_2CO_3 solution:

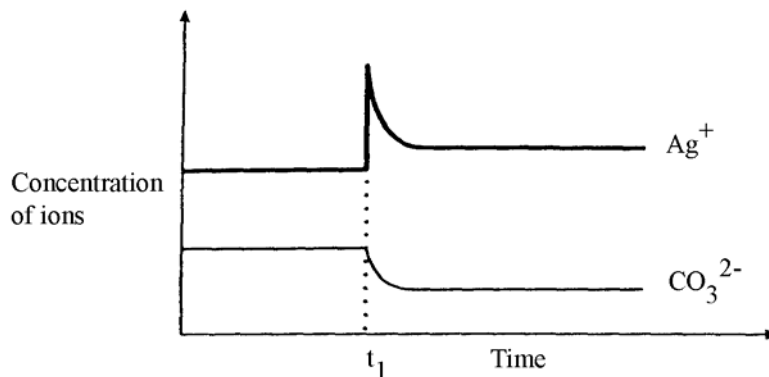

What change occurred at time t_1 ?

- Water was added
 - $\text{AgNO}_{3(s)}$ was added
 - $\text{Na}_2\text{CO}_{3(s)}$ was added
 - The temperature was increased
8. The relationship between the solubility of SrF_2 and its K_{sp} is
- solubility = $\frac{\sqrt[3]{K_{sp}}}{4}$
 - solubility = $\sqrt[3]{\frac{K_{sp}}{2}}$
 - solubility = $\sqrt[3]{\frac{K_{sp}}{4}}$
 - solubility = $\sqrt{K_{sp}}$
9. Which of the following compounds will form a saturated solution with the greatest concentration of Ag^+ ?
- AgI ($K_{sp} = 8.3 \times 10^{-17}$)
 - AgBr ($K_{sp} = 7.7 \times 10^{-13}$)
 - AgCl ($K_{sp} = 1.8 \times 10^{-10}$)
 - AgCN ($K_{sp} = 2.0 \times 10^{-12}$)
10. Which of the following 0.1 M solutions will have the greatest electrical conductivity?
- HNO_2
 - H_2SO_3
 - H_3PO_4
 - $\text{C}_6\text{H}_5\text{OH}$
11. Normal rain has a pH of approximately 6 as a result of dissolved
- oxygen
 - carbon dioxide
 - sulphur dioxide
 - nitrogen dioxide

12. Which of the following units can be used to represent solubility?
- g
 - mol
 - mol/L
 - mL/s
13. A 3.0 L solution of NiCl_2 is found to have a chloride concentration of 0.60 M. The concentration of nickel(II) ions in this solution is
- 0.30 M
 - 0.60 M
 - 0.90 M
 - 1.2 M
14. Which of the following causes a precipitate to form when $\text{Sr}^{2+}_{(\text{aq})}$ is added but not when $\text{Zn}^{2+}_{(\text{aq})}$ is added?
- S^{2-}
 - Cl^-
 - SO_4^{2-}
 - CO_3^{2-}
15. The solubility of PbS is 2.9×10^{-14} M. What is the value of K_{sp} for PbS ?
- 8.4×10^{-28}
 - 2.9×10^{-14}
 - 5.8×10^{-14}
 - 1.7×10^{-7}
16. Consider the following equation $\text{AgCl}_{(\text{s})} \rightleftharpoons \text{Ag}^+_{(\text{aq})} + \text{Cl}^-_{(\text{aq})}$

Which of the following graphs represents the relationship between $[\text{Ag}^+]$ and $[\text{Cl}^-]$ system at a constant temperature?

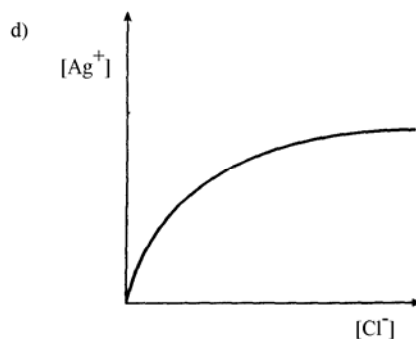
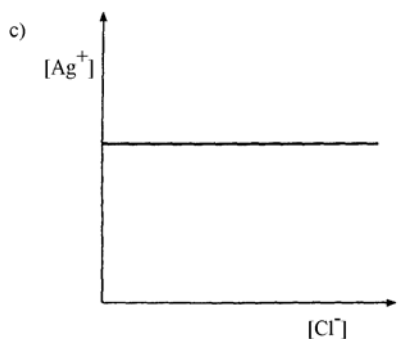
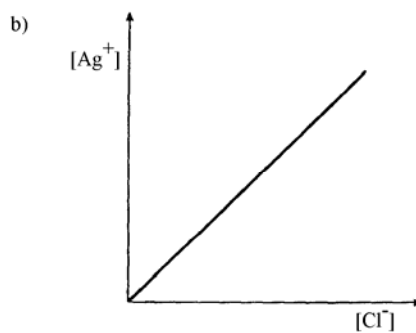
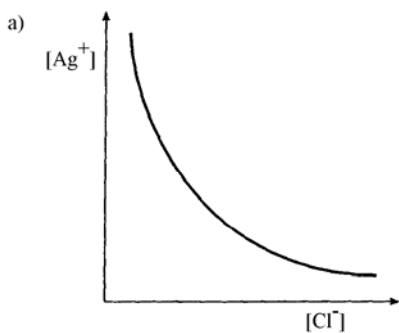

17. An oxidizing agent is a substance which
- accepts protons
 - donates protons
 - accepts electrons
 - donates electrons
18. Consider the following oxidation-reduction reaction:
- $$\text{Mn}^{2+} + \text{IO}_3^- + \text{H}_2\text{O} \rightarrow \text{MnO}_4^- + \frac{1}{2}\text{I}_2 + 2\text{H}^+$$
- The reducing agent is
- I_2
 - IO_3^-
 - H_2O
 - Mn^{2+}
19. A substance that is most likely to gain electrons during a spontaneous redox reaction is
- I_2
 - Li
 - Au
 - Hg
20. The equation for the spontaneous reaction between Sn and 1.0 M HCl is
- $\text{Sn} + \text{H}_2 \rightarrow \text{Sn}^{2+} + 2\text{H}^+$
 - $\text{Sn} + 2\text{H}^+ \rightarrow \text{Sn}^{2+} + \text{H}_2$
 - $\text{Sn} + \text{Cl}_2 \rightarrow \text{Sn}^{2+} + 2\text{Cl}^-$
 - $\text{Sn} + 2\text{Cl}^- \rightarrow \text{Sn}^{2+} + \text{Cl}_2$
21. Consider this redox equation
- $$\text{C}_2\text{O}_4^{2-} + \text{MnO}_2 \rightarrow \text{Mn}^{2+} + 2\text{CO}_2$$
- As a result of this reaction the oxidation number of each C atom has
- increased by 1
 - increased by 2
 - decreased by 2
 - decreased by 4
22. A solution of lead(II) nitrate could be safely stored in a container made of
- Cu
 - Ni
 - Fe
 - Zn
23. Which of the following represents a redox reaction?
- $\text{H}_2\text{CO}_3 \rightarrow \text{H}_2\text{O} + \text{CO}_2$
 - $\text{CuS} + \text{H}_2 \rightarrow \text{H}_2\text{S} + \text{Cu}$
 - $\text{AgNO}_3 + \text{NaCl} \rightarrow \text{AgCl} + \text{NaNO}_3$
 - $2\text{HCl} + \text{Na}_2\text{SO}_3 \rightarrow 2\text{NaCl} + \text{H}_2\text{O} + \text{SO}_2$

Use the following electrochemical cell diagram to answer questions 24 and 25.

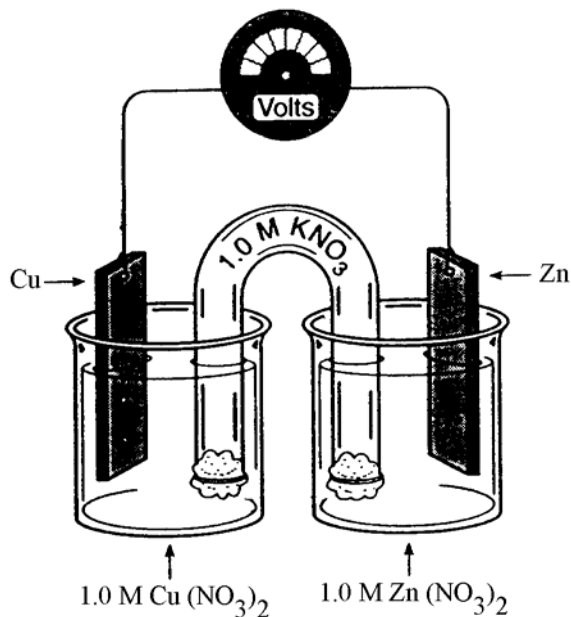

24. As the above cell operates
- copper ions migrate into the salt bridge
 - cations migrate towards the zinc electrode
 - the mass of the copper electrode increases
 - anions migrate towards the copper electrode
25. The initial cell voltage is
- 0.42 V
 - 0.91 V
 - 1.10V
 - 1.28 V
26. The electrolysis of a molten salt involves the migration of
- anions only
 - cations only
 - electrons only
 - both cations and anions
27. When electroplating an iron spoon with silver, the half-reaction taking place on the spoon is
- $\text{Ag}^+_{(\text{aq})} + \text{e}^- \rightarrow \text{Ag}_{(\text{s})}$
 - $\text{Ag}_{(\text{s})} \rightarrow \text{Ag}^+_{(\text{aq})} + \text{e}^-$
 - $\text{Fe}^{2+}_{(\text{aq})} + 2\text{e}^- \rightarrow \text{Fe}_{(\text{s})}$
 - $\text{Fe}_{(\text{s})} \rightarrow \text{Fe}^{2+}_{(\text{aq})} + 2\text{e}^-$

28. Consider the following equilibrium

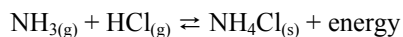

Which of the following will result in a decrease in the mass of NH_4Cl ?

- a) adding NH_3
- b) removing HCl
- c) decreasing the volume
- d) decreasing the temperature

29. Consider the following equilibrium

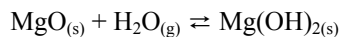

The equilibrium constant expression is

- a) $K_{eq} = [\text{H}_2\text{O}]$
- b) $K_{eq} = \frac{1}{[\text{H}_2\text{O}]}$
- c) $K_{eq} = \frac{[\text{Mg}(\text{OH})_2]}{[\text{MgO}]}$
- d) $K_{eq} = \frac{[\text{Mg}(\text{OH})_2]}{[\text{MgO}][\text{H}_2\text{O}]}$

30. Which of the following reactions most favours the reactants?

- a) $\text{CH}_4(\text{g}) \rightleftharpoons 2\text{H}_2(\text{g}) + \text{C}(\text{s})$ $K_{eq} = 1.2 \times 10^{-9}$
- b) $\text{SbCl}_5(\text{g}) \rightleftharpoons \text{SbCl}_3(\text{g}) + \text{Cl}_2(\text{g})$ $K_{eq} = 2.5 \times 10^{-2}$
- c) $\text{N}_2\text{O}_4(\text{g}) \rightleftharpoons 2\text{NO}_2(\text{g})$ $K_{eq} = 4.5 \times 10^{-1}$
- d) $\text{C}(\text{s}) + \text{CO}_2(\text{g}) \rightleftharpoons 2\text{CO}(\text{g})$ $K_{eq} = 1.4 \times 10^1$

31. Consider the following equilibrium

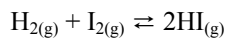

The pressure on the system is increased by reducing the volume. When comparing the new equilibrium with the original equilibrium,

- a) all concentrations remain constant
- b) the concentrations of all species have increased
- c) reactant concentrations have increased while product concentrations have decreased
- d) reactant concentrations have decreased while product concentrations have increased

32. Consider the following equilibrium

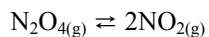

A 1.00 L container is initially filled with 0.200 mol N_2O_4 . At equilibrium, 0.160 mol NO_2 are present. What is the equilibrium concentration of N_2O_4 ?

- a) 0.040 mol/L
b) 0.080 mol/L
c) 0.120 mol/L
d) 0.160 mol/L
33. Which of the following anions could be used to separate Pb^{2+} from Ba^{2+} by precipitation?
- a) NO_3^-
b) SO_4^{2-}
c) Cl^-
d) CO_3^{2-}
34. The net ionic equation for the reaction between $\text{Sr}(\text{OH})_2$ and H_2SO_4 is
- a) $\text{H}^+ + \text{OH}^- \rightarrow \text{H}_2\text{O}$
b) $\text{Sr}^{2+} + \text{SO}_4^{2-} \rightarrow \text{SrSO}_4$
c) $\text{Sr}(\text{OH})_2 + \text{H}_2\text{SO}_4 \rightarrow \text{SrSO}_4 + 2\text{H}_2\text{O}$
d) $\text{Sr}^{2+} + 2\text{OH}^- + 2\text{H}^+ + \text{SO}_4^{2-} \rightarrow \text{SrSO}_4 + 2\text{H}_2\text{O}$
35. Consider the rate diagram below for the following reaction

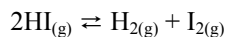

Which of the following occurs at time t_1 ?

- a) addition of H_2
b) addition of HI
c) addition of a catalyst
d) a decrease in volume

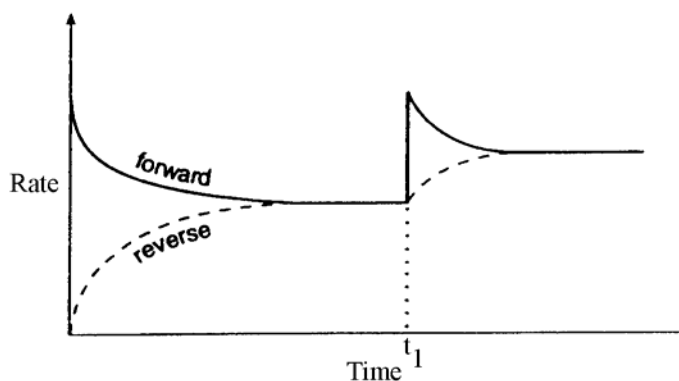

36. Which of the following is possible for an acid?

	ACID STRENGTH	CONCENTRATION	pH
a)	strong	0.01 M	2.0
b)	weak	0.01 M	1.0
c)	strong	3 M	5.5
d)	weak	3 M	-0.5

37. Consider the following equilibrium

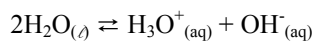

A small amount of HCl is added to water and equilibrium is reestablished. When comparing the new equilibrium with the original equilibrium,

- a) $[\text{H}_3\text{O}^+]$ and pH both decreased
b) $[\text{H}_3\text{O}^+]$ and pH both increased
c) $[\text{H}_3\text{O}^+]$ increased and pH decreased
d) $[\text{H}_3\text{O}^+]$ decreased and pH increased
38. The oxidation number of carbon in $\text{C}_2\text{O}_4^{2-}$ is
- a) +3
b) +4
c) +5
d) +6

39. Consider the following redox reaction

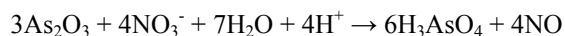

The oxidizing agent is

- a) H^+
b) H_2O
c) NO_3^-
d) As_2O_3
40. When W_2O_5 is converted to WO_2 in a redox reaction, the W has been
- a) reduced since its oxidation number has increased
b) reduced since its oxidation number has decreased
c) oxidized since its oxidation number has increased
d) oxidized since its oxidation number has decreased

41. A student investigating redox reactions recorded the following results

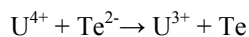
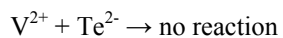

Based on these results, the strengths of the oxidizing agents, arranged from strongest to weakest, are

- a) V^{2+} , Te , U^{4+}
- b) U^{4+} , Te , V^{2+}
- c) U^{3+} , Te^{2-} , V^{2+}
- d) V^{2+} , Te^{2-} , U^{3+}

42. A spontaneous redox reaction occurs when Sn^{2+} is mixed with

- a) I_2
- b) Cu
- c) Mg
- d) Ca

Use the following diagram to answer questions 43, 44 and 45.

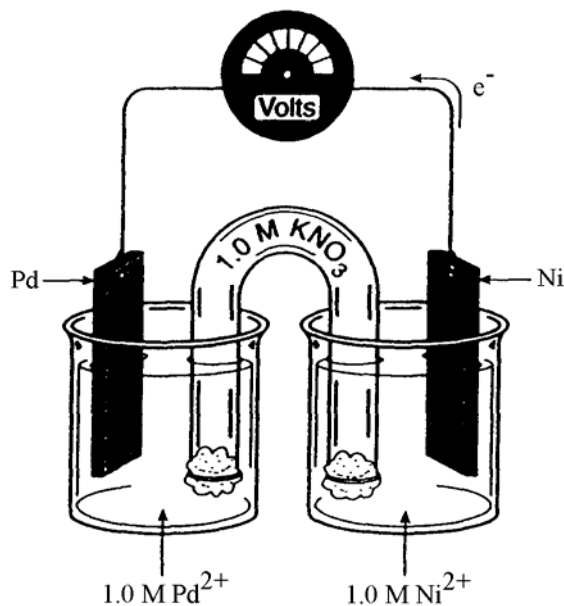

43. As the cell operates, the electrons flow from the nickel electrode to the palladium electrode. The reaction occurring at the anode is

- a) $\text{Pd} \rightarrow \text{Pd}^{2+} + 2\text{e}^-$
- b) $\text{Ni} \rightarrow \text{Ni}^{2+} + 2\text{e}^-$
- c) $\text{Pd}^{2+} + 2\text{e}^- \rightarrow \text{Pd}$
- d) $\text{Ni}^{2+} + 2\text{e}^- \rightarrow \text{Ni}$

44. As the cell operates
- both the K^+ and the NO_3^- migrate into the nickel half-cell
 - both the K^+ and the NO_3^- migrate into the palladium half-cell
 - the K^+ migrates into the nickel half-cell and the NO_3^- migrates into the palladium half-cell
 - the K^+ migrates into the palladium half-cell and the NO_3^- migrates into the nickel half-cell

45. The initial cell voltage is 1.21 V. The reduction potential of Pd^{2+} is

- 1.21 V
- 0.95 V
- +0.95 V
- +1.21 V

46. Consider the following reaction mechanism:

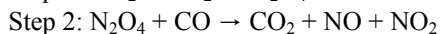
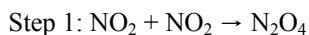

In the overall reaction, N_2O_4 is a

- product
- catalyst
- reactant
- reaction intermediate

47. Consider the following chemicals:

I	water
II	oxygen gas
III	nitrogen gas

At 25°C, a piece of iron rusts in the presence of

- I only
- III only
- I and II only
- II and III only

48. During the electrolysis of 1.0 M Na_2SO_4 , the reaction at the cathode is

- $Na^+ + e^- \rightarrow Na$
- $2SO_4^{2-} \rightarrow S_2O_8^{2-} + 2e^-$
- $2H_2O \rightarrow O_2 + 4H^+ + 4e^-$
- $2H_2O + 2e^- \rightarrow H_2 + 2OH^-$

PART B Written Response

You will be expected to communicate your knowledge and understanding of chemical principles in a clear and logical manner. Your steps and assumptions leading to a solution must be written in the spaces below the questions. Answers must include units where appropriate and be given to the correct number of significant figures. **For questions involving calculation, full marks will NOT be given for providing only an answer.**

(1) 1. a) Write the net ionic equation for the precipitation reaction that occurs when solutions of NaIO_3 and AgNO_3 are mixed.

(3) b) Using appropriate calculations, explain why a precipitate forms when 15.0 mL of 0.50 M NaIO_3 are added to 35.0 mL of 0.50 M AgNO_3 .

$$(\text{K}_{\text{sp}}(\text{AgIO}_3) = 3.1 \times 10^{-8})$$

(2) 2. What is the maximum $[\text{CO}_3^{2-}]$ that can exist in a 1.3×10^{-4} M AgNO_3 solution?

$$(\text{K}_{\text{sp}}(\text{Ag}_2\text{CO}_3) = 8.2 \times 10^{-12})$$

(3) 3. Balance the following redox reaction:

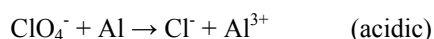

4. Consider the following reaction:

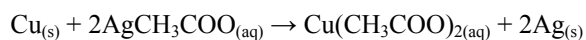

A piece of Cu wire is placed into 1.00 L of a saturated solution of silver acetate, AgCH_3COO . When all the Ag^+ has reacted, 2.00 g of Cu has been used.

(1) a) Write the net ionic equation for the reaction between Cu and Ag^+ .

(3) b) Calculate the K_{sp} of AgCH_3COO .

(3) 5. a) Draw a diagram for the following electrochemical cell.

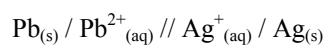

(2) b) i) Label the electrode & electrolytes used

(2) ii) Write the anode & cathode half reactions that occur.

(2) iii) Write the balanced net equation and calculate the cell voltage.

(1) iv) Use an arrow on the diagram to indicate the direction of electron flow.

(1) v) Indicate the direction of anion and cation migration also.

(1) 6. a) Identify a metal that can be used to cathodically protect the iron hull of a ship.

(1) b) Explain how the metal you chose prevents the iron from rusting.

7. Consider the following cell used for the electrolysis of 1.0 M KI solution containing a few drops of phenolphthalein indicator.

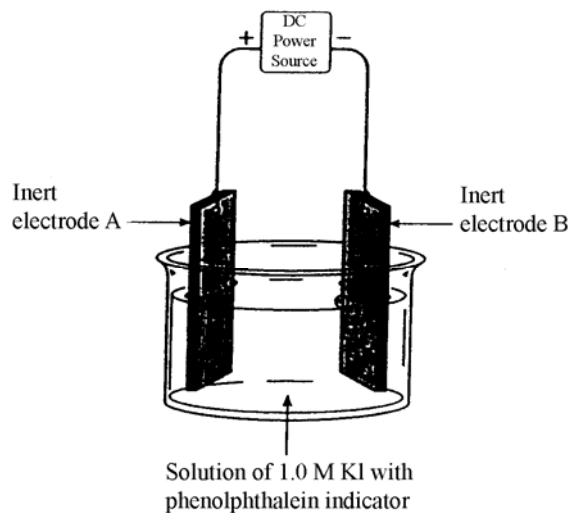

- (1) a) Write the equation for the half-reaction taking place at electrode A.
- (2) b) As the cell operates, gas bubbles form and the solution turns pink around electrode B.
- i) Identify the gas that forms.

- ii) Explain why the solution turns pink.

8. Consider the following equilibrium:

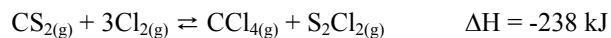

- (2) a) Sketch a potential energy diagram for the reaction above and label ΔH .

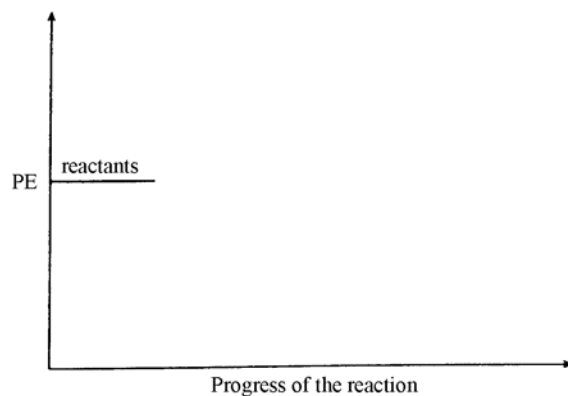

- (1) b) Some CS_2 is added and equilibrium is then reestablished. State the direction of the equilibrium shift and the resulting change in $[\text{Cl}_2]$.

- (1) c) The temperature is decreased and equilibrium is then reestablished. What will the effect be on the value of K_{eq} ?

- (4) 9. A 100.00 mL sample of a saturated solution of $\text{Ca}(\text{OH})_2$ is evaporated to dryness. The mass of the solid residue is 0.125 g. Calculate the solubility product of $\text{Ca}(\text{OH})_2$.

- (2) 10. Write the net ionic equation representing the reaction that occurs when equal volumes of 0.20 M H_2SO_4 and 0.20 M $\text{Ba}(\text{NO}_3)_2$ are mixed together.

- (4) 11. Nicotinic acid, $\text{HC}_6\text{H}_4\text{NO}_2$, is a weak acid found in vitamin B. Calculate the pH of 0.100 M $\text{HC}_6\text{H}_4\text{NO}_2$ ($K_a = 1.4 \times 10^{-5}$).

- (4) 12. Which of the following are redox reactions, state why or why not. If a redox reaction identify the element reduced, the element oxidized, the oxidizing agent, the reducing agent.

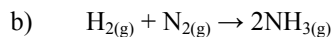
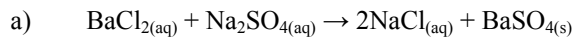

- (2) 13. Consider the following redox reaction:

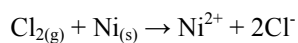

Calculate the E° for the reaction above.

- (3) 14. Determine the mass of magnesium deposited at the cathode by the electrolysis of MgO using a current of 2.00 A for 4.00 hours.

- (4) 15. An electroplating firm wishes to plate 6.35 g of copper onto a pair of baby shoes from a $\text{Ca}(\text{NO}_3)_2$ solution. If a current of 4.00 amperes is used, calculate the time required. At which electrode should the shoe be attached?